

Drainage Design for Highways



12/18/2020
Revision 3.5
Atlanta, GA 30308

This document was developed as part of the continuing effort to provide guidance within the Georgia Department of Transportation in fulfilling its mission to provide a safe, efficient, and sustainable transportation system through dedicated teamwork and responsible leadership supporting economic development, environmental sensitivity and improved quality of life. This document is not intended to establish policy within the Department, but to provide guidance in adhering to the policies of the Department.

Your comments, suggestions, and ideas for improvements are welcomed.

Please send comments to:

State Design Policy Engineer
Georgia Department of Transportation
One Georgia Center
600 W. Peachtree Street, 26th Floor
Atlanta, Georgia 30308

DISCLAIMER

The Georgia Department of Transportation maintains this printable document and is solely responsible for ensuring that it is equivalent to the approved Department guidelines.

Revision History

Revision Number	Revision Date	Revision Summary
Rev. 1	February 2016	<p>3.4.1 & 10.2.2.1 - Added text referencing Concept Development requirements</p> <p>4.1.1.2 - Separated Table 4.3 into two tables: Table 6.3 and Table 7.1</p> <p>5.4.1 - Text revised to correct roadside and median channel design guidelines</p> <p>7.2.3.1 - Updated Table 7.3</p> <p>7.3.3 - Added Elliptical Concrete and Metal Pipes section</p> <p>8.2.1 - Added baffle requirements to the summary of quantities sheet</p> <p>8.2.12 - Added reference to Geotechnical Manual for Pipe Culvert Material Alternates table</p> <p>10.1.1 - Added text and a figure illustrating the physiographic regions in Georgia</p> <p>10.2.2.1 - Outfall level exclusion #6 supplemented with additional information. Post-construction stormwater report guidance clarified.</p> <p>10.2.2.2 - Water quality volume calculation supplemented. Indicated that P should be found by using the project’s midpoint on the NOAA Precipitation Frequency Data Server. Revised the WQ_v and V_s formulas to result in units of ft^3 rather than acre-ft. Added clarification about uniform sizing criteria</p> <p>Ch. 10 - Multiple sections Indicated that post-construction BMP underdrains are <u>typically</u> 6” in diameter</p> <p>10.4.2 - Grass channel example problem revised. Grass channel max width clarified by region.</p> <p>10.4.3 - Additional siting criteria provided for wet enhanced swales</p> <p>10.4.5 - Indicated that bioslope media should typically not be grassed & revised the Maintenance Considerations</p> <p>10.4.9 & 10.4.10 - Specified that the 5-mile radius exclusion should be for “public-use” airports</p> <p>10.4.11 - OGFC description text revised</p> <p>Appendix I Removed the Post-Construction Stormwater Report from the Manual. The latest version is available at</p>

		<p>http://www.dot.ga.gov/PS/DesignManuals/DesignGuides</p> <p>Appendix I (formerly App. J) - Moved Appendix J to Appendix I with the removal of the Post-Construction Stormwater Report. Removed the Hydraulic Engineering Field Report and referenced the GDOT Automated Survey Manual</p>
Rev. 2	July 12, 2016	Converted manual to standard template
Rev. 2.1	August 1, 2016	Chapter 12 – Updated references to GDOT Survey Manual. Updated USGS publication. Added Computer model to list of accepted models. Updated other minor info.
Rev.3	December 28, 2016	<p>Chapter 3 – Provided references to the MS4 PDP.</p> <p>10.2.1.1 – Added additional guidance on downstream hydrologic assessments</p> <p>10.2.1.2 – Revised water balance calculations and provided additional guidance</p> <p>Figure 10.2-4 – Updated figure to include new MS4 areas added in GDOT’s 2017 MS4 permit</p> <p>Updated language throughout Chapter 10 indicating that MS4 Post-Construction Stormwater Reports are not required for projects outside of MS4 areas.</p> <p>10.4 – Removed specific recurring maintenance requirements for BMPs and referred to GDOT’s Stormwater System Inspection and Maintenance Manual</p> <p>10.4 – Revised various figures to more clearly indicate where filter fabric should be located.</p> <p>10.4.7 – Revised the bioretention basin design filter bed max drain time from 0.5 days to 1 day.</p> <p>Chapter 12 – Updated requirements for bridge replacements and new locations</p> <p>Appendix A – Added additional acronyms</p> <p>Appendix H – Revised list to include new MS4 areas added in GDOT’s 2017 MS4 permit</p> <p>Appendix J – New guidance on in-situ infiltration testing for infiltration BMPs</p>
Rev. 3.1	December 11, 2017	<p>Chapter 3 – 3.2 - Added content regarding geometric elements</p> <p>3.3 - Updated MS4 PDP flowchart hyperlink.</p> <p>3.3.4 - Added OMAT to approval of OGFC.</p> <p>3.4.1 - Updated information regarding MS4 Concept Report Summary. Added info regarding Drainage Area Maps and Post-Construction BMP Summary Table as items needed for concept hydrology study. Added content regarding Stormwater BMP Planning tool</p> <p>3.4.2 – Updated project documentation content</p> <p>Table 3.1 – Added NMFS (National Marine Fisheries Service) and Regional Endangered Species Permit.</p>

		<p>Chapter 4 – 4.1.2 – Updated information regarding rainfall intensity. Deleted Figure 4.2 - GSMM rainfall data locations</p> <p>Chapter 5 – 5.6 - Updated GDOT Construction Standards and Details</p> <p>Chapter 6 – 6.2.1 – Updated Figure 6.1 - Gutter spread in a typical urban section</p> <p>Table 6.3 – Added info regarding width of bike lane</p> <p>Chapter 10 – Entire chapter has been updated</p> <p>Chapter 12 - Replaced OEL to OES. Replaced Office of Environment/Location to Office of Environmental Services</p> <p>Chapter 13 – 13.2.3 - Replaced Ecology Technical Report with Ecology Assessment of Effects Report. Added information regarding ESAs</p> <p>Appendix A - Replaced OEL to OES. Replaced Office of Environment/Location to Office of Environmental Services</p> <p>Appendix D – Added Table 5 - Runoff Curve Numbers</p> <p>Appendix G – Updated Notice of Intent sample</p> <p>Appendix I – Replaced OEL to OES. Replaced Office of Environment/Location to Office of Environmental Services</p> <p>Appendix J – Updated Geo-Hydrologic Assessment procedures</p>
Rev 3.2	February 9, 2018	<p>Chapter 10 -</p> <p>10.4.1.1 Revised formula 10.4-2</p> <p>10.4.5 Revised Figure 10.4-7 – Sizing Criteria Volumes Illustration</p> <p>10.6.1 Updated recommended maximum strip length to 48 feet</p> <p>10.6.5 Removed references to the bioslope maximum flow path length</p>
Rev 3.3	May 9, 2018	Chapter 10 - Revised Figure 10.3-2
Rev 3.4	August 10, 2018	Updated GDOT logo throughout
Rev 3.5	December 18, 2020	<p>Updated template to comply with corporate branding guidelines</p> <p>Updated revision number of chapters that were at 2.# to coincide with the rest of the manual.</p> <p>3.4.1 - Replaced reference to Appendix J with Chapter 10</p> <p>4.1.1.1 - Updated hyperlink</p> <p>4.1.3.2 - Updated hyperlink</p> <p>4.1.5 - Updated hyperlink</p> <p>6.1 - Updated reference hyperlink</p> <p>6.1.2 - Revised gutter flow information</p>

		<p>6.2.1 - Revised gutter spread information</p> <p>6.3.1 – Updated reference hyperlink</p> <p>6.3.2 - Updated reference hyperlinks</p> <p>6.4.1 - Updated reference hyperlinks</p> <p>6.5 - Updated hyperlink</p> <p>6.5.1 - Revised grate inlet information</p> <p>9.2 - Updated hyperlink</p> <p>9.6 - updated information on transition of temporary sediment basins to permanent post-construction BMPs</p> <p>10.2.3 - revised downstream analysis policy</p> <p>10.4.1.2 - revised policy for approval of drainage basins pre/post development, removed OGFC from treatment train discussion</p> <p>10.5.2 - updated guidance on when to use Appendix J</p> <p>10.5.3 - update process for using a BMP other than pre-approved list</p> <p>10.5.4 - updated guidance for design/approval of offline BMPs</p> <p>10.6.1 - added ability to size for over-conveyance to increase WQ removal, revised Application and Site Feasibility criteria, simplified Data for Design</p> <p>10.6.2 - added ability to size for over-conveyance to increase WQ removal, revised Application and Site Feasibility Criteria</p> <p>10.6.3 - updated Stormwater Management Suitability, Application and Site Suitability, Data for Design, and General Design Criteria, updated Enhanced Dry Swale Sizing and Enhanced Dry Swale Example Calculation. Also updated Design Elements – Enhanced Wet Swale, Enhanced Wet Swale Sizing, and Enhanced Wet Swale Example Calculation</p> <p>10.6.4 - added coordination requirements for BMP selection. Updated General Design Criteria and Alternative Design Options</p> <p>10.6.5 - updated Application and Site Suitability and Data for Design</p> <p>10.6.7 - updated Description, Application and Site Suitability, Data for Design, Bioretention Basin Sizing, and Bioretention Example Calculation</p> <p>10.6.8 - updated Description, Application and Site Suitability, and Data for Design</p> <p>10.6.9 - updated Application and Site Suitability and Data for Design, Wet Detention Pond Sizing</p>
--	--	---

		<p>10.6.10 - updated Data for Design</p> <p>10.6.11 - updated Pollutant Removal Capabilities to 80%</p> <p>10.7 - updated Stage-Discharge Relationship (Performance Curve) details regarding the principal outlet and emergency spillway</p> <p>10.8.2 - included approval steps for using a flow bypass structure</p> <p>10.8.4 - removed pea gravel diaphragm from pre-treatment options</p> <p>Revised Figures 10.3-2, 10.6.1-3, 10.6.3-3, 10.6.4-1, 10.6.4-2, 10.6.5-1, 10.6.5-2, 10.6.6-2, 10.6.6-3, 10.6.6-4, 10.6.7-1, 10.6.7-2, 10.6.10-1</p> <p>Removed Figures 10.6.3, 10.6.4, 10.6.11-2, 10.8-5</p> <p>Removed Equation 10.4-4</p> <p>Revised Equation 10.4-6</p> <p>Numbered Equations 10.4-11, 10.4-14, and 10.4-15</p> <p>Revised Table 10.5-1</p> <p>Appendix J – Simplified Geo-Hydrologic Assessment Appendix</p>
--	--	--

Intentionally Left Blank

List of Effective Chapters

Document	Revision Number	Revision Date
List of Effective Chapters	3.0	12/18/20
Table of Contents	3.2	12/18/20
Chapter 1. Introduction	3.0	12/18/20
Chapter 2. Agency Coordination and Regulations	3.0	12/18/20
Chapter 3. Stormwater Planning	3.2	12/18/20
Chapter 4. Hydrology & Hydraulics	3.0	12/18/20
Chapter 5. Channels	3.0	12/18/20
Chapter 6. Pavement Drainage	3.0	12/18/20
Chapter 7. Storm Drain Design	3.0	12/18/20
Chapter 8. Culverts	3.0	12/18/20
Chapter 9. Erosion and Sediment Control Guidelines	3.0	12/18/20
Chapter 10. Post-Construction Stormwater Design Guidelines	3.4	12/18/20
Chapter 11. Stream & Wetland Restoration Concepts	3.0	12/18/20
Chapter 12. Requirements for Hydraulic Design Studies	3.2	12/18/20
Chapter 13. Bridge Deck Drainage Systems	3.0	12/18/20
Appendix A. Acronyms	3.2	12/18/20
Appendix B. FEMA Agency Coordination, Regulations, and Documentation	3.0	12/18/20
Appendix C. Designer's Checklist for Project Documentation	3.0	12/18/20
Appendix D. Manning's Tables	3.0	12/18/20
Appendix E. FHWA Culvert Design Form	3.0	12/18/20
Appendix F. Culvert Design Data Checklist	3.0	12/18/20
Appendix G. Sample NOI	3.0	12/18/20
Appendix H. MS4 Areas	3.0	12/18/20
Appendix I. Additional Bridge Information	3.0	12/18/20
Appendix J. Geo-Hydrologic Assessment	3.2	12/18/20

Intentionally Left Blank

Table of Contents

Revision History	i
List of Effective Chapters	vii
Table of Contents.....	ix
Chapter 1. Introduction - Contents	1-i
1.1 Introduction.....	1-1
1.2 How to Use This Manual	1-1
1.3 General Project Workflow	1-2
1.4 Overview of Manual Contents	1-2
1.5 Manual Maintenance.....	1-3
1.6 Acknowledgements.....	1-4
Chapter 2. Agency Coordination and Regulations - Contents.....	2-i
2.1 Introduction.....	2-1
2.1.1 Related Publications	2-1
2.2 Significant Laws Affecting Drainage.....	2-2
2.2.1 Overview of Federal Laws.....	2-3
2.2.2 Overview of Georgia State Laws.....	2-6
2.3 Coordination with Regulatory Agencies.....	2-8
2.3.1 Federal Agencies.....	2-8
2.3.2 State and Local Agencies	2-12
2.3.3 Coordination Process Flow	2-18
2.4 NFIP	2-18
2.4.1 Flood Insurance	2-19
2.4.2 Flood Disaster Protection.....	2-19
2.4.3 Local Community	2-19
2.4.4 NFIP Maps.....	2-20
2.5 NFIP Requirements	2-20
2.5.1 FEMA Coordination.....	2-20
2.5.2 Longitudinal Roadway Encroachments	2-21
2.5.3 Categories and Recommendations for Bridges and Culverts	2-22
2.6 Design Data Required for Project Involving FEMA Floodplains	2-23
2.6.1 Publications	2-23
2.6.2 Maps.....	2-23
2.6.3 Survey Data, Plans, Reports.....	2-24

- 2.6.4 Regulations and Policy Guides 2-24
- 2.6.5 Computer Models and Manuals 2-24
- 2.7 Design Methods/Procedures for all Encroachments 2-24
- 2.8 NFIP Map Revisions 2-24
 - 2.8.1 Conditional Letter of Map Revision (CLOMR) 2-25
- Chapter 2 References..... 2-27
- Chapter 3. Stormwater Planning - Contents 3-i
 - 3.1 Introduction..... 3-1
 - 3.2 Objectives and Conceptualization 3-1
 - 3.3 Project Workflow and Design Considerations..... 3-2
 - 3.3.1 Sources of Information..... 3-2
 - 3.3.2 Hydrology and Hydraulic Design 3-3
 - 3.3.3 Construction Stormwater 3-3
 - 3.3.4 Post-Construction Stormwater 3-4
 - 3.3.5 Low Impact Development and Green Infrastructure Practices..... 3-5
 - 3.4 Project Requirements 3-6
 - 3.4.1 GDOT Policy..... 3-6
 - 3.4.2 Project Documentation..... 3-8
 - 3.4.3 Permitting and Other Agencies 3-9
- Chapter 3 References..... 3-11
- Chapter 4. Hydrology & Hydraulics - Contents 4-i
 - 4.1 Hydrology 4-1
 - 4.1.1 Guidelines..... 4-1
 - 4.1.1.1 Acceptable Design Methods 4-1
 - 4.1.1.2 Design Discharge Criteria..... 4-4
 - 4.1.1.3 Design Storm Characteristics 4-5
 - 4.1.2 General Design Data 4-5
 - 4.1.3 Peak Flow Determination Procedures..... 4-6
 - 4.1.3.1 Regional Evaluation 4-6
 - 4.1.3.2 The NRCS TR-55 Method 4-6
 - 4.1.3.3 The Rational Method 4-7
 - 4.1.4 Hydrograph Types and Development..... 4-12
 - 4.1.5 Other Relevant Hydrologic Information 4-12
 - 4.2 Hydraulics..... 4-12

4.2.1	Introduction	4-12
4.2.2	General.....	4-13
4.2.3	General Flow Classification.....	4-13
4.2.4	Basic Principles	4-13
4.2.4.1	Continuity Equation	4-14
4.2.4.2	Energy Equation.....	4-14
4.2.4.3	Momentum Equation	4-16
4.2.5	Weirs and Orifices	4-16
4.2.5.1	Weirs.....	4-16
4.2.5.2	Orifices.....	4-18
4.2.6	Open-Channel Flow	4-19
4.2.6.1	Introduction	4-19
4.2.6.2	Detailed Flow Classification.....	4-19
4.2.6.3	Manning's Equation.....	4-19
4.2.6.4	Froude Number	4-21
4.2.6.5	Specific Energy Diagram and Evaluation of Critical Depth.....	4-23
4.2.7	Closed-Conduit Flow.....	4-25
4.2.7.1	Types of Flow in Closed Conduits	4-25
4.2.7.2	Energy Losses	4-26
	Chapter 4 References.....	4-27
	Chapter 5. Channels - Contents.....	5-i
5.1	Introduction.....	5-1
5.2	Design Policy	5-2
5.3	Open-Channel Hydraulics	5-2
5.3.1	Types of Flow	5-3
5.3.2	Manning's Equation for Mean Velocity and Discharge.....	5-3
5.3.3	Use of Design Charts to Find Depth of Flow, Velocity, Critical Slope, and Adequacy of Channel Lining	5-4
5.3.4	Stream Channel Analysis and Design	5-4
5.3.4.1	Stream Morphology	5-5
5.3.4.2	Cross Sections	5-5
5.3.4.3	Manning's n Value Selection	5-5
5.3.4.4	Calibration	5-6
5.3.4.5	Slope-Area Method	5-7

- 5.3.4.6 One-Dimensional Gradually-Varied Flow Profile Analysis..... 5-7
- 5.3.4.7 Special Analysis Techniques..... 5-10
 - 5.3.4.7.1 Two-Dimensional Analysis 5-10
 - 5.3.4.7.2 Unsteady Flow Analysis 5-11
- 5.3.4.8 Switchback Phenomenon 5-12
- 5.4 Roadside and Median Channel Guidelines and Criteria 5-13
 - 5.4.1 Design Storms 5-13
 - 5.4.2 Channel Shape and Protection 5-13
 - 5.4.3 Channel Alignment 5-13
 - 5.4.4 Channel Grade 5-14
 - 5.4.5 Stream-Bank Protection from Erosion 5-14
 - 5.4.6 Typical Design Data Required 5-14
- 5.5 Roadside and Median Channel Design Procedures 5-15
- 5.6 Safety 5-16
- Chapter 5 References..... 5-18
- Chapter 6. Pavement Drainage - Contents..... 6-i
 - 6.1 Guidelines..... 6-1
 - 6.1.1 Introduction..... 6-1
 - 6.1.2 Hydroplaning..... 6-1
 - 6.2 Gutter Spread and Design Storm Frequency 6-6
 - 6.2.1 Gutter Spread 6-6
 - 6.2.2 Design Storm Frequency 6-7
 - 6.3 Gutter Flow 6-9
 - 6.3.1 Longitudinal Slope - Gutter Grades..... 6-9
 - 6.3.2 Cross Slopes 6-9
 - 6.4 Gutter Flow Computations 6-10
 - 6.4.1 Uniform Cross Section Procedure..... 6-11
 - 6.4.2 Composite Cross Slopes 6-12
 - 6.4.3 V-Sections 6-14
 - 6.5 Inlet Types 6-14
 - 6.5.1 Characteristics and Uses of Inlets..... 6-15
 - 6.5.2 Inlet Flow Capacity and Interception 6-16
 - 6.6 Design Procedures 6-28
 - 6.6.1 Collect and Analyze Existing Data 6-28
 - 6.6.2 Preliminary Layout - Placement of Inlets Due to Geometric Controls 6-28

- 6.6.3 Determine Drainage Areas and "Q's" 6-29
- 6.6.4 Placement of Inlets on Continuous Grades 6-30
- 6.6.5 Low Point and Flanking Structures..... 6-30
- Chapter 6 References..... 6-34
- Chapter 7. Storm Drain Design - Contents 7-i
- 7.1 Introduction..... 7-1
 - 7.1.1 Definition..... 7-1
- 7.2 Design Guidelines..... 7-1
 - 7.2.1 Design Storm Frequency 7-2
 - 7.2.2 Maximum Structure Spacing 7-3
 - 7.2.3 Conduit Criteria..... 7-3
 - 7.2.3.1 Minimum Pipe Size and Material 7-3
 - 7.2.3.2 Minimum Cover/Clearances 7-6
 - 7.2.3.3 Minimum/Maximum Velocity 7-6
 - 7.2.4 Data Collection and Preliminary Sketch 7-6
 - 7.2.5 Cooperative Storm Drainage Projects..... 7-7
 - 7.2.6 Outlet Concerns..... 7-7
 - 7.2.7 Access Holes..... 7-8
 - 7.2.8 Curved Alignment 7-8
- 7.3 Hydraulics of Storm Drain Systems..... 7-9
 - 7.3.1 Sizing of Storm Drain 7-9
 - 7.3.1.1 Full Flow..... 7-9
 - 7.3.1.2 Part-Full Flow 7-10
 - 7.3.2 Minimum Grades 7-11
 - 7.3.3 Elliptical Concrete and Metal Pipes..... 7-12
- 7.4 Design Procedures 7-13
 - 7.4.1 Energy Loss Estimation for Preliminary Layout..... 7-13
 - 7.4.2 Preliminary Layout 7-14
- 7.5 Energy Grade Line / Hydraulic Grade Line..... 7-18
 - 7.5.1 Evaluating Tailwater..... 7-18
 - 7.5.2 Energy Losses 7-19
 - 7.5.2.1 Exit Loss 7-19
 - 7.5.2.2 Pipe Friction Loss..... 7-19
 - 7.5.2.3 Bend Loss 7-20

7.5.2.4	Junction Loss	7-21
7.5.2.5	Access Hole and Inlet Losses.....	7-21
7.5.2.6	Relative Access Hole Size.....	7-23
7.5.2.7	Pipe Diameter	7-23
7.5.2.8	Flow Depth	7-24
7.5.2.9	Relative Flow.....	7-24
7.5.2.10	Plunging Flow	7-25
7.5.2.11	Benching.....	7-26
7.5.2.12	Energy Losses.....	7-27
7.6	Energy Grade Line Evaluation Procedure	7-27
7.7	Computer Programs.....	7-35
7.8	Additional Guidance.....	7-35
7.9	Represent Drainage Design on the Plans	7-36
	Chapter 7 References.....	7-37
	Chapter 8. Culverts - Contents.....	8-i
8.1	Introduction.....	8-1
8.1.1	Definition.....	8-1
8.1.2	Symbols.....	8-1
8.2	Design Guidelines.....	8-3
8.2.1	General Requirements.....	8-3
8.2.2	Design Storm Event.....	8-5
8.2.3	Allowable Headwater	8-5
8.2.4	Tailwater Relationship.....	8-7
8.2.5	Maximum Outlet Velocity / Energy Dissipators.....	8-7
8.2.6	Aquatic Organism Passage (AOP).....	8-8
8.2.7	Minimum Velocity.....	8-12
8.2.8	Minimum Required Cover and Clearances.....	8-12
8.2.9	Improved Inlets	8-12
8.2.10	Culvert Extensions	8-12
8.2.11	Channel Changes	8-13
8.2.12	Pipe Culverts	8-13
8.2.13	Box Culverts	8-14
8.2.14	Bottomless Culverts	8-15
8.2.15	Fall.....	8-15

- 8.2.16 Acceptable Culvert Design Methods 8-15
- 8.2.17 Hydraulic Reports 8-15
- 8.2.18 Culverts Located Within a FEMA Regulatory Floodway 8-16
- 8.3 Typical Information Needed for Design 8-16
- 8.4 Culvert Design Approach 8-16
 - 8.4.1 Types of Control 8-17
- 8.5 Culvert Design Method 8-30
 - 8.5.1 Culvert Design Method 8-30
 - 8.5.2 Inlet Control Calculations 8-31
 - 8.5.3 Outlet Control Calculations 8-37
 - 8.5.4 Evaluation of Results 8-40
 - 8.5.5 Energy Dissipation 8-40
 - 8.5.6 Culvert Outlet Velocity and Velocity Modification 8-41
 - 8.5.7 Outlet Velocity Considerations for Culverts on Mild Slopes 8-41
 - 8.5.8 Outlet Velocity Considerations for Culverts on Steep Slopes 8-42
 - 8.5.9 Types of Energy Dissipation 8-42
 - 8.5.9.1 Hydraulic Jump Energy Dissipators 8-42
 - 8.5.9.2 Impact Basins 8-43
 - 8.5.9.3 Drop Structures With Energy Dissipation 8-44
 - 8.5.9.4 Stilling Wells 8-45
 - 8.5.9.5 Riprap Stilling Basins 8-45
- 8.6 Design Software 8-46
 - 8.6.1 Culvert Design Using HY-8 8-46
- Chapter 8 References 8-49
- Chapter 9. Erosion and Sediment Control Guidelines - Contents 9-i
 - 9.1 Introduction 9-1
 - 9.2 NPDES Program 9-1
 - 9.3 Georgia NPDES General Permit Regulations and Requirements 9-2
 - 9.4 ESPCPs 9-3
 - 9.4.1 Introduction 9-3
 - 9.4.2 Policy Guidelines 9-4
 - 9.4.3 Description of the Complete ESPCP 9-5
 - 9.4.4 Signatory Requirements for ESPCPs 9-7
 - 9.4.5 Revisions to the ESPCP During the Life of a Project 9-8
 - 9.5 Right-of-Way 9-8

- 9.6 BMP Location and Design Criteria 9-9
- Chapter 9 References..... 9-10
- Chapter 10. Post-Construction Stormwater - Contents..... 10-i
- 10.1 Introduction..... 10-1
 - 10.1.1 Chapter 10 Content Overview 10-1
 - 10.1.2 Additional Resources 10-1
- 10.2 The Need for Post-Construction Stormwater Management 10-2
 - 10.2.1 Introduction to Post-Construction Stormwater Management 10-2
 - 10.2.2 Stormwater Management for Special Environmental Concerns 10-3
 - 10.2.3 Detention Analysis & Downstream Hydrologic Assessment ⁽¹⁰⁻¹⁸⁾ 10-4
 - 10.2.4 Water Balance Calculations ⁽¹⁰⁻¹⁸⁾ 10-7
 - 10.2.4.1 Basic Equations 10-7
- 10.3 Project Applicability 10-15
 - 10.3.1 Project Level Exclusions 10-16
 - 10.3.2 Outfall Level Exclusions 10-18
 - 10.3.3 Infeasibilities 10-19
 - 10.3.4 MS4 Post-Construction Stormwater Management Documentation..... 10-20
- 10.4 MS4 Post-Construction Stormwater Management Minimum Standards 10-21
 - 10.4.1 Stormwater Runoff Quality / Reduction 10-21
 - 10.4.1.1 Runoff Reduction Volume 10-22
 - 10.4.1.2 Water Quality Volume 10-24
 - 10.4.1.2.1 Calculating Water Quality Volume Peak Flow 10-25
 - 10.4.2 Stream Channel / Aquatic Resource Protection 10-26
 - 10.4.3 Overbank Flood Protection 10-35
 - 10.4.4 Extreme Flood Protection..... 10-36
 - 10.4.5 How the Sizing Criteria Volumes Work Together 10-37
 - 10.4.6 LID and GI Considerations..... 10-38
- 10.5 Post-Construction Stormwater BMP Selection Criteria..... 10-39
 - 10.5.1 Overview/Introduction of Selection Criteria 10-39
 - 10.5.2 Information Required 10-40
 - 10.5.3 BMP Menu 10-41
 - 10.5.4 Selection Process 10-41
- 10.6 Post-Construction Stormwater BMP Design Criteria 10-47
 - 10.6.1 Filter Strip 10-48
 - 10.6.2 Grass Channel..... 10-57

10.6.3	Enhanced Swale	10-68
10.6.4	Infiltration Trench	10-89
10.6.5	Bioslope.....	10-101
10.6.6	Sand Filter	10-110
10.6.7	Bioretention Basin.....	10-126
10.6.8	Dry Detention Basin	10-140
10.6.9	Wet Detention Pond.....	10-153
10.6.10	Stormwater Wetland.....	10-170
10.6.11	Open-Graded Friction Course	10-185
10.7	Detention Design	10-188
10.8	Common BMP Components	10-203
10.8.1	Forebay	10-203
10.8.2	Flow Bypass Structure	10-204
10.8.3	Underdrains	10-207
10.8.4	Level Spreaders.....	10-208
10.9	Bridge Stormwater Quality Considerations.....	10-211
10.9.1	Bridge Stormwater Challenges	10-211
10.9.2	Minimizing Direct Discharge.....	10-212
10.9.3	Bridge Best Management Practices	10-212
10.10	Safety Considerations for Stormwater BMPs.....	10-214
10.10.1	Motorist Safety	10-214
10.10.2	Public Safety	10-214
10.10.3	Maintenance Personnel Safety.....	10-215
	Chapter 10 References.....	10-216
	Chapter 11. Stream & Wetland Restoration Concepts - Contents	11-i
11.1	Introduction.....	11-1
11.2	Permitting	11-1
11.3	Stream Design and Restoration	11-3
11.3.1	Introduction.....	11-3
11.3.2	Definitions.....	11-3
11.3.3	Natural Stream Design.....	11-4
11.3.3.1	Intent of Natural Stream Design.....	11-5
11.3.3.2	Recommended Design Approach	11-8
11.4	Wetland Restoration/Mitigation	11-9
	Chapter 11 References.....	11-12

Chapter 12. Requirements for Hydraulic Design Studies - Contents 12-i

12.1 Design Criteria 12-1

12.1.1 Design Frequencies and Freeboards 12-1

12.1.2 Discharge Determination 12-4

12.1.3 Flood Stages..... 12-5

12.1.4 Backwater..... 12-5

12.1.5 Flow Velocities..... 12-6

12.1.6 Bridge Scour..... 12-6

12.1.7 Bridge Abutment Protection 12-7

12.1.8 Guide Banks (Spur Dikes)..... 12-7

12.1.9 Detour Structures..... 12-8

12.1.10 Non-vehicular (Pedestrian) Bridge Structures..... 12-9

12.1.11 Longitudinal Roadway Encroachments..... 12-9

12.1.12 Hydraulic Modeling Floodplain Constrictions/Obstructions and Abnormal Flood Stage Conditions 12-10

12.2 Design Data Required..... 12-11

12.2.1 Required Data from Project Manager..... 12-11

12.2.2 Reference Publications for Design Guidance 12-12

12.2.3 Maps..... 12-12

12.2.4 Other Plans, Reports, and Miscellaneous Data..... 12-13

12.2.5 Regulations and Design Guides..... 12-13

12.2.6 GDOT Acceptable Computer Models..... 12-13

12.2.7 The Internet 12-13

12.3 Design Methods/Procedures – Hydraulic and Hydrological Studies 12-14

12.3.1 Methods/Procedures – All Riverine Bridge Projects 12-14

12.3.2 Contents of Riverine Hydraulic and Hydrologic Study 12-25

12.3.3 Methods/Procedures – All Tidal Projects..... 12-25

12.3.4 Contents of Tidal Hydraulic and Hydrological Study..... 12-29

12.3.5 Methods/Procedures – All Riverine Major Culvert Projects 12-29

12.3.6 Contents of Riverine Hydraulic and Hydrological Major Culvert Study 12-36

12.3.7 Hydraulic and Hydrologic Study Procedures/Design Office and Consultant Responsibilities..... 12-36

Chapter 12 References..... 12-44

Chapter 13. Bridge Deck Drainage Systems - Contents..... 13-i

13.1 Introduction..... 13-1

13.2 Design Guidelines..... 13-1

13.2.1 General Design Criteria 13-1

13.2.2 Design Spread and Frequency 13-2

13.2.3 Bridge Deck Drainage Systems 13-2

13.3 Information Needed for Design 13-3

13.4 Design Methods and Procedures 13-3

13.5 Typical Deck Drain Details Used by GDOT 13-4

13.6 Analysis of Circular Scuppers 13-6

Chapter 13 References 13-8

Appendix A. Acronyms A-1

Appendix B. FEMA Agency Coordination, Regulations, and Documentation B-1

Appendix C. Designer’s Checklist for Project Documentation C-1

Appendix D. Manning’s Tables D-1

Appendix E. FHWA Culvert Design Form E-1

Appendix F. Culvert Design Data Checklist F-1

Appendix G. Sample NOI G-1

Appendix H. MS4 Areas H-1

Appendix I. Additional Bridge Information I-1

Appendix J. Geo-Hydrologic Assessment J-1

Intentionally Left Blank

Chapter 1. Introduction - Contents

Chapter 1. Introduction - Contents	1-i
1.1 Introduction.....	1-1
1.2 How to Use This Manual	1-1
1.3 General Project Workflow	1-2
1.4 Overview of Manual Contents	1-2
1.5 Manual Maintenance	1-3
1.6 Acknowledgements	1-4

Chapter 1. Introduction

1.1 Introduction

The *Manual on Drainage Design for Highways* was originally adopted in 1966 with the ultimate purpose of bringing uniformity in the design of drainage structures in conformity with accepted policies of the Georgia Department of Transportation (GDOT) and the Federal Highway Administration (FHWA). Prior to the last revision in 2008, the manual was revised in 1975 and 1988. On January 3, 2012, GDOT was issued a National Pollutant Discharge Elimination System (NPDES) stormwater permit from the Georgia Environmental Protection Division (EPD), a division of the Georgia Department of Natural Resources (GADNR). This permit authorizes GDOT to discharge stormwater from a municipal separate storm sewer system (MS4) to the waters of the state of Georgia using appropriate stormwater management. In addition to incorporating new information to meet permit requirements, GDOT has also revised this manual with the intention of making it policy based and “Georgia specific”, rather than a how-to manual. As such, the manual has also been updated with policy changes since the release of the 2008 manual.

This chapter will provide a discussion on the intended use of this manual, general project work flow regarding drainage design for GDOT projects, and an overview of the manual contents, manual maintenance procedures, and manual acknowledgements.

1.2 How to Use This Manual

The chapter discussions within this manual follow GDOT design policies, guidelines, and state-of-the-practice design procedures. The purpose of this manual is to provide sufficient information and policy on the subjects of hydrologic and hydraulic analyses as related to highway stormwater infrastructure design. During the development of this manual, numerous drainage manuals and guides from the FHWA, other states, certain municipalities, and organizations were obtained and referenced. When necessary throughout the chapters, these outside manuals and guides are cited for the designer’s reference.

The designer is assumed to be knowledgeable in the use of the referenced items. This manual cannot incorporate computer program user manuals or keep current with these programs and/or the latest drainage-related federal regulations. Designers of GDOT drainage structures should follow the guidelines presented in this manual and reference the appropriate user manual or technical support group for computer program use. The FHWA hydraulic-related publications are found at <http://www.fhwa.dot.gov/engineering/hydraulics/>

When the designer encounters a situation that is not described in this manual or in the cited references, the GDOT Office of Design Policy and Support or the GDOT project manager should be contacted for assistance. Designers are encouraged to request assistance as soon as questions or problems arise since timely help can often provide a more efficient and effective design process and can lead to the generation of more applicable solutions.

1.3 General Project Workflow

An adequate drainage structure is defined as one that meets or exceeds the goals of standard engineering practice and is consistent with what a reasonably competent and prudent designer would specify under similar circumstances.

The first step in any drainage design project is a hydrologic analysis to estimate the design discharge. Hydraulic analysis is then completed on those preliminary or trial selections of alternative designs that are judged to meet the site conditions and to accommodate the design discharge. The final step in the design process is the engineering evaluation of the trial designs and the approval of the selected final design. This approval may involve consideration of a wide variety of factors such as legal issues, flood hazards, cost, environmental, and other site-specific concerns.

1.4 Overview of Manual Contents

This manual primarily contains design policies and guidelines in a condensed format for use by the designer. Although the basic concepts of hydrology and hydraulics are introduced in this manual, the designer will be provided references to various publications within each chapter for more detailed guidelines, step-by-step procedures, and additional example problems. There are select example problems provided in the appendices of this manual as well. This manual is not intended to be a complete guide to all hydrologic or hydraulic problems encountered and it does not provide guidance on complex issues regarding those problems. Each design project is unique and this manual should not be used as a substitute for good, sound engineering judgment that comes with experience.

The general contents of each chapter are summarized below.

Chapter 1 - Introduction

Chapter 1 introduces the manual, includes the intended use of this manual and general project work flow regarding drainage design for GDOT projects, and provides an overview of the manual contents, manual maintenance procedures, and manual acknowledgements.

Chapter 2 - Agency Coordination and Regulations

Chapter 2 provides an overview of the relationship between the roadway drainage design and the regulatory framework under which roadway projects are permitted and constructed. Also included is some background information on the federal laws and regulations regarding NPDES, Federal Emergency Management Agency (FEMA), U.S. Coast Guard (USCG) navigation permits, United States Army Corps of Engineers (USACE) 404 permits, as well as FHWA requirements.

Chapter 3 - Stormwater Planning

Chapter 3 contains an overview of the stormwater planning and design process, in accordance with GDOT policies, necessary for both construction and post-construction stormwater measures.

Chapter 4 - Hydrology & Hydraulics

Chapter 4 discusses the methods used to determine peak runoff flow rates and volumes, such as the Rational Method, regression equations, and Technical Release-55 (TR-55). The chapter also introduces the basic concepts and general equations for open-channel and closed-conduit flow.

Chapter 5 - Channels

Chapter 5 discusses roadside and median channel analysis and design and provides an introduction to natural stream channel analysis and design.

Chapter 6 - Pavement Drainage

Chapter 6 discusses pavement drainage and includes curb and gutter flow, spread of water on pavement, hydroplaning, types of inlets, inlet capacity on grades and in sumps, inlet spacing, and flanking inlets.

Chapter 7 - Storm Drain Design

Chapter 7 provides guidance on storm drain design and discussion, factors related to, and evaluation of the hydraulic grade line and energy grade line.

Chapter 8 - Culverts

Chapter 8 provides design procedures for the hydraulic design of highway culverts, including results of culvert analysis using HY-8 culvert analysis software and a summary of the design philosophy contained in the American Association of State Highway and Transportation Officials (AASHTO) Highway Drainage Guidelines, Chapter 4.

Chapter 9 - Soil Erosion and Sediment Control Guidelines

Chapter 9 introduces construction stormwater management guidelines for erosion and sediment control purposes. Chapter 9 defines the construction stormwater requirements for GDOT projects, includes GDOT common practices, and provides guidance on meeting applicable permit requirements.

Chapter 10 - Post-Construction Stormwater Design Guidelines

Chapter 10 introduces post-construction stormwater management concepts, defines post-construction requirements of GDOT projects, and provides guidance on meeting these requirements and designing post-construction best management practices (BMPs).

Chapter 11 - Stream & Wetland Restoration Concepts

Chapter 11 presents an overview of typical stream restoration concepts followed by an overview of wetland restoration designs.

Chapter 12 - Bridge Hydraulic Design Criteria

Chapter 12 provides hydraulic design criteria for all existing and/or proposed river/tidal bridge sites and for culverts that meet any of the several conditions listed in the chapter.

Chapter 13 - Bridge Deck Drainage Systems

Chapter 13 provides the fundamentals of bridge deck drainage design, including pavement design, inlet design, and interception requirements.

1.5 Manual Maintenance

The manual is available through the GDOT Design Policies & Guidelines website at

<http://www.dot.ga.gov/PS/DesignManuals/DesignGuides>.

It is the designer’s responsibility to determine if there are any manual updates by periodically checking the webpage above and/or by contacting the GDOT Office of Design Policy and Support or the GDOT project manager.

If errors are discovered in this manual, please report them to the GDOT Office of Design Policy and Support at the address or e-mail address shown below or to the GDOT Project Manager, so that corrections can be made.

Georgia Department of Transportation

Office of Design Policy and Support

One Georgia Center

600 West Peachtree Street, 26th Floor

Atlanta, Georgia 30308

E-mail: DrainageManual@dot.ga.gov

1.6 Acknowledgements

The Department wishes to acknowledge the key personnel within the Department, FHWA, and at URS Corporation that contributed to the preparation of this manual. The shared technical knowledge, experiences, and perspectives have endeavored to produce a tool that will aide in meeting the requirements of the new NPDES MS4 permit, while presenting the GDOT policies and design guidelines in an organized format.

Sincere appreciation is extended to the following Department personnel who provided reviews for GDOT policy conformance and presentation of subject matter:

- | | |
|-----------------------------|-----------------------|
| Mr. Brad McManus, PE | Ms. Susan Beck, PE |
| Mr. Jon D. Griffith, PG, PE | Mr. Jacob Achorn, EIT |

Special thanks are extended to the following persons who collaborated in the preparation of the manual chapters, provided quality control and quality assurance reviews, and offered technical editing for the manual chapters:

- | | |
|--|---------------------------------|
| Mr. Ted Sherrod, PE, CPESC, CPSWQ, CMS4S | Ms. Melanie Gardner, EI |
| Mr. Charles Crowell, PE, CPESC, CPSWQ, CFM | Mr. Jeff Henry, PE |
| Mr. Nick Castronova, PE | Ms. Liz Twiss |
| Mr. Roger Cox, PE, CPESC, CFM | Ms. Beth Calloway |
| Mr. Nate Buttermore, PE | Ms. Carly Queen |
| Mr. Fred Halterman, PE, CFM | Mr. Alex Nice, PhD, PE, LEED AP |
| Ms. Ashley Folmar, PE | Mr. Dennis Hoyle, PE, PLS |
| Ms. Debbie Cottrell, PE | Ms. Cynthia Nurmi, PE |
| Ms. Meme Diaz, PE, CFM | Mr. Leon Kim, PE |

Chapter 2. Agency Coordination and Regulations - Contents

Chapter 2. Agency Coordination and Regulations - Contents2-i

2.1 Introduction.....2-1

 2.1.1 Related Publications.....2-1

2.2 Significant Laws Affecting Drainage2-2

 2.2.1 Overview of Federal Laws.....2-3

 2.2.2 Overview of Georgia State Laws.....2-6

2.3 Coordination with Regulatory Agencies.....2-8

 2.3.1 Federal Agencies2-8

 2.3.2 State and Local Agencies.....2-12

 2.3.3 Coordination Process Flow2-18

2.4 NFIP2-18

 2.4.1 Flood Insurance.....2-19

 2.4.2 Flood Disaster Protection2-19

 2.4.3 Local Community.....2-19

 2.4.4 NFIP Maps2-20

2.5 NFIP Requirements2-20

 2.5.1 FEMA Coordination2-20

 2.5.2 Longitudinal Roadway Encroachments2-21

 2.5.3 Categories and Recommendations for Bridges and Culverts.....2-22

2.6 Design Data Required for Project Involving FEMA Floodplains2-23

 2.6.1 Publications2-23

 2.6.2 Maps.....2-23

 2.6.3 Survey Data, Plans, Reports2-24

 2.6.4 Regulations and Policy Guides2-24

 2.6.5 Computer Models and Manuals2-24

2.7 Design Methods/Procedures for all Encroachments2-24

2.8 NFIP Map Revisions.....2-24

 2.8.1 Conditional Letter of Map Revision (CLOMR)2-25

Chapter 2 References.....2-27

Chapter 2. Agency Coordination and Regulations

2.1 Introduction

This chapter provides an overview of the relationship between roadway drainage design and the regulatory framework under which roadway projects are permitted and constructed. The *State of Georgia Department of Transportation Plan Development Process-2000*, Revision November 2011 manual and *GDOT Environmental Procedures Manual (EPM)*, [\(2-4\)](#) February 2012 should be referenced for more detailed information on the coordination that must take place between GDOT and various federal and state agencies to permit construction of GDOT projects.

GDOT's mission is to provide a safe, connected, and environmentally sensitive transportation system that enhances Georgia's economic competitiveness by working efficiently and communicating effectively to create strong partnerships. In keeping with the GDOT mission statement, multiple levels of coordination must take place between GDOT and various federal, state, and local entities as a project progresses from inception through construction. Permits must be acquired in accordance with existing laws and regulations before a project can be approved for construction. Most of the drainage related permitting and agency coordination that is done for roadway projects will involve compliance with regulations that are in place to protect the environment. Drainage design decisions made on a project play a significant role in determining the extent of a project's impacts to environmental resources along the project corridor and therefore also play a role in facilitating a project's progression through agency review and permitting.

Environmental laws require that every effort be made to avoid and/or minimize harm to environmental resources such as the following:

- Waters of the United States (wetlands, streams, and open waters)
- Vegetative buffers on streams
- Threatened and endangered (T&E) species and their habitat (e.g., protection of fish and wildlife)
- Floodplains
- Navigable waters
- Coastal zones
- Historic resources
- Non-historic Section 4(f) resources (publicly owned parks, recreation areas, wildlife and waterfowl refuges)
- Cemeteries
- Archeological sites

2.1.1 Related Publications

The following publications were used as references in the preparation of this chapter. The designer should refer to these publications for further information regarding the legal framework within which stormwater runoff may be discharged from roadway systems to the natural environment. GDOT and FHWA references provide guidance on agency coordination that must take place to secure permits to construct roadways and their associated drainage systems.

- AASHTO Highway Drainage Guidelines, chapter 5 [\(2-1\)](#)

- AASHTO Model Drainage Manual, chapter 2 [\(2-2\)](#)
- FHWA's *Federal-Aid Policy Guide*, 23 CFR 650.115(a), "Procedures for Coordinating Highway Encroachments on Floodplains with the Federal Emergency Management Agency (FEMA)" [\(2-3\)](#)
- *GDOT Environmental Procedures Manual* [\(2-4\)](#)
<http://www.dot.ga.gov/doingbusiness/PoliciesManuals/roads/Environmental/GDOT-EPM.pdf>
- *State of Georgia Department of Transportation Plan Development Process* [\(2-5\)](#)
<http://www.dot.ga.gov/PartnerSmart/Business/Documents/4050-1.pdf>

2.2 Significant Laws Affecting Drainage

Engineers and environmental specialists should remain informed on proposed and enacted legislation and understand how such legislation relates to roadway drainage and bridge hydraulic decisions when designing a project.

The descending order of law supremacy is federal, state, and local. Except as provided for in the statutes or constitution of the higher level of government, the higher level is not bound by the laws, rules, or regulations of a lower level. Many laws of one level of government are passed to enable that level to comply with or implement provisions of laws of the next higher level. For example, the Georgia Environmental Protection Act (GEPA) is analogous to the National Environmental Protection Act (NEPA). GEPA must be followed on state-funded projects when the state action does not trigger the NEPA process.

The impacts of roadway runoff to downstream floodplains and to the downstream built environment must also be considered during the design process. The roadway drainage designer must be consistent with both the FEMA regulations and the local floodplain ordinance, where practicable (if impacts are extended into private property) to confirm floodplain impacts are within allowable limits and the proper documentation and permits are in place prior to the commencement of construction. Coordination with FEMA, the National Flood Insurance Program (NFIP), and local communities, with respect to the impacts of roadway construction on floodplains, is covered in greater detail later in this chapter.

Presidential proclamations and Executive orders, federal agency regulations/documents having general applicability and legal effect, documents required to be published by an Act of Congress, and other federal agency documents of public interest are published daily in the *Federal Register*. The general and permanent rules published in the *Federal Register* are codified and published annually in the *Code of Federal Regulations (CFR)*. Compilations of Federal Statutory Law, revised annually, are available in the *United States Code (USC)*.

The CFR is available for viewing at:

<http://www.gpo.gov/fdsys/browse/collectionCfr.action?collectionCode=CFR>

A searchable database of the USC is available at: <http://uscode.house.gov/>

Georgia laws are published in the *Official Code of Georgia Annotated (OCGA)*, available at <http://www.lexisnexis.com/hottopics/gacode/>

Figure 2.1 - Federal and state laws timeline

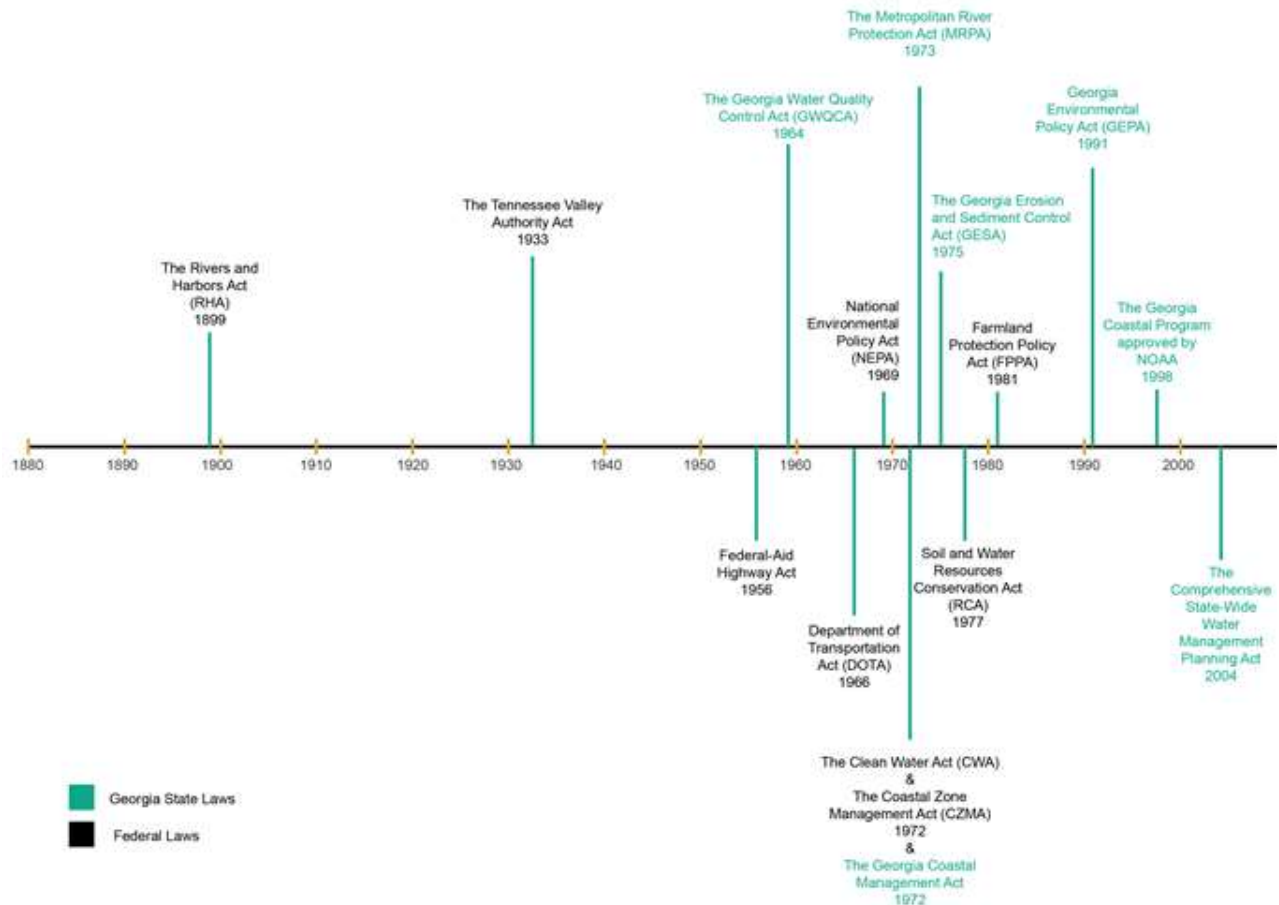

2.2.1 Overview of Federal Laws

Federal law has implications that affect drainage design, although it may not directly address drainage. For example, environmental impacts resulting from drainage design will be a significant consideration as regulatory agencies review projects for permit approvals. Some of the more significant federal acts with elements that relate to drainage from roadways are listed below with a brief description of the provisions of each act. A timeline presenting the inception dates of the federal and state acts is provided in Figure 2.1.

- THE RIVERS AND HARBORS ACTS (RHA) (33 USC 401, 403, 407).** The original RHA was passed in 1899. Several amendments to the Act have since been passed. These amendments address projects and activities in navigable waters and harbor and river improvements. Several of these amendments provide for a number of regulatory authorities, the implementation of which has evolved over time. Section 9 of the Act gives regulatory authority to USACE and the USCG regarding construction of structures across navigable waters of the United States. The USCG has regulatory authority over bridges and causeways while the USACE has regulatory authority over any dam, dike, or other similar structure not including a bridge or causeway. Section 13 of the Act grants regulatory authority to the USACE over the discharge of refuse into navigable waters. In the absence of a permit, such discharge of refuse is prohibited. Section 11 of the RHA authorizes the

USACE to establish harbor lines, or arbitrary lines beyond which wharves and other structures may not be built.

- **THE TENNESSEE VALLEY AUTHORITY ACT OF 1933 (16 USC 831).** This Act formed the Tennessee Valley Authority (TVA). TVA's mission is to provide flood control within the Tennessee Valley, improve navigation on the Tennessee River, provide electric power, and promote "agricultural and industrial development" in the region.
- **FEDERAL-AID HIGHWAY ACT OF 1956 (23 USC 101 et seq.).** This Act provides for the administration of the Federal-Aid Highway Program. Proposed federal-aid projects must be adequate to meet the existing and probable future traffic needs and conditions in a manner conducive to safety, durability, and economy of maintenance. The projects must also be designed and constructed according to standards best suited to accomplish these objectives and to conform to the needs of each locality. Various amendments to the original Federal-Aid Highway Act have been enacted. Some of the more significant amendments added regulations for the following:
 - Protection of Section 4(f) resources
 - Addressing environmental justice, or the fair treatment and meaningful involvement of all people regardless of race, color, national origin, or income with respect to the development, implementation, and enforcement of environmental laws, regulations, and policies
 - Control of soil erosion from roadway construction

The FHWA administers the Federal-Aid Highway Program in cooperation with the states. Projects classified as exempt are not subject to full FHWA oversight. However, the FHWA retains approval authority for the environmental documentation on exempt projects.

- **DEPARTMENT OF TRANSPORTATION ACT (DOTA) OF 1966 (49 USC 101, 80 Stat. 941).** This Act established the Department of Transportation and set forth its powers, duties, and responsibilities to establish, coordinate, and maintain an effective administration of the transportation programs of the Federal Government.
- **NATIONAL ENVIRONMENTAL POLICY ACT (NEPA) OF 1969 (42 USC 4321).** This Act is the overarching environmental law for federal-aid projects. The NEPA requires entities receiving federal aid to evaluate the impacts of their actions on the environment and prepare a public disclosure of environmental impacts in an environmental document, also known as a NEPA document, before project decisions are made. The NEPA document should not be written to defend a project decision that has already been made. The Council on Environmental Quality (CEQ) was established within the Executive Office of the President to administer NEPA. Each federal agency must assume responsibility for meeting NEPA guidelines with guidance from CEQ and oversight from the U.S. Environmental Protection Agency (EPA). The GEPA is the state analog to the NEPA and must be complied with for state-aid projects not receiving federal funds. In some circumstances, federal environmental laws may trigger a NEPA review regardless of whether or not a project receives federal funds. The roadway engineer or NEPA analyst and local government sponsors should

coordinate with the GDOT Office of Environmental Services to determine which federal requirements apply to state-funded projects.

Following are the three classes of environmental documentation under the NEPA:

1. Class I, Environmental Impact Statement (EIS)/Record of Decision (ROD) – An EIS is prepared for projects whose actions will have a significant impact on the environment.
2. Class II, Categorical Exclusion (CE) – A CE is prepared for projects that do not individually or cumulatively have a significant environmental impact.
3. Class III, Environmental Assessment (EA)/Finding of No Significant Impact (FONSI) – An EA is prepared for projects in which the environmental impact is not clearly defined. All actions that are not Class I or II are Class III. All actions in this class require the preparation of an EA to determine the appropriate document required.

Early Coordination is the means by which federal, state, and local agencies, and project stakeholders are informed of a proposed project. Determining the level of NEPA documentation begins with the Early Coordination process. The final decision on the level of documentation is not made until the environmental studies are complete. All environmental documents are subject to Early Coordination.

The environmental document is prepared during Preliminary Design as project decisions are being made. All environmental studies and documents shall be prepared in accordance with the GDOT EPM.

- **THE CLEAN WATER ACT (CWA) OF 1972 (33 USC 1251).** The EPA is responsible for oversight and overall administration of the CWA. The CWA amended the Federal Pollution Control Act of 1948 to provide the statutory basis for the NPDES Permit Program and the basic infrastructure for regulating the discharge of pollutants from point sources to waters of the United States. Section 402 of the CWA specifically requires the EPA to develop and implement the NPDES program. The CWA allows the EPA to authorize the NPDES Program to state governments, which enables states to perform the permitting, administrative, and enforcement functions of the NPDES Program. In Georgia, the NPDES Program is implemented by the EPD of the GADNR.

Section 404 of the CWA establishes a program to regulate the discharge of dredged and fill material into waters of the United States, including wetlands. Responsibility for administering and enforcing Section 404 is shared by the USACE and EPA. Under Section 404, the USACE is responsible for regulating and issuing permits for proposed discharges into waters of the United States, including wetlands. As the overall Administrator of the CWA, the EPA retains oversight and veto authority over the USACE.

- **THE COASTAL ZONE MANAGEMENT ACT (CZMA) OF 1972 (Public Law 92-583, 86 Stat. 1280, 16 USC 1451-1466).** The Act, administered by the National Oceanic Atmospheric Administration's (NOAA) Office of Ocean and Coastal Resource Management (OCRM), provides for management of the nation's coastal resources, including the Great Lakes, and balances economic development with environmental conservation. This Act encourages states to be responsible stewards of coastal land by implementing state-administered management programs.

- **SOIL AND WATER RESOURCES CONSERVATION ACT (RCA) OF 1977 (16 USC 2001-2009).** The RCA provides the United States Department of Agriculture (USDA) broad strategic assessment and planning authority for the conservation, protection, and enhancement of soil, water, and related natural resources. This Act directs the USDA to develop a National Soil and Water Conservation Program (SWCP), and to conduct an appraisal of the nation's soil, water, and related resources at five-year intervals. The SWCP and the appraisals are conducted under the jurisdiction of the Natural Resources Conservation Service (NRCS). Analyses conducted by the NRCS in carrying out the provisions of this Act are to be in conjunction with the Georgia Soil and Water Conservation Commission (GSWCC), conservation districts, and appropriate citizen groups. The GSWCC works closely with the NRCS and models many of its recommended soil conservation and water quality practices after NRCS conservation practice standards.
- **FARMLAND PROTECTION POLICY ACT (FPPA) OF 1981 (7 USC 4201).** This Act is contained within the Agriculture and Food Act of 1981. Projects are subject to FPPA requirements if they may irreversibly convert farmland (directly or indirectly) to nonagricultural use and are completed by a federal agency or with assistance from a federal agency. For the purpose of FPPA, farmland includes prime farmland, unique farmland, and land of statewide or local importance. GDOT projects receiving federal aid must be coordinated with the NRCS to determine if there is farmland involvement in accordance with the FPPA. If there is involvement, the project engineer or ecologist must further coordinate with the NRCS to calculate a Farmland Conversion Impact Rating. Depending on this rating, additional roadway alignment alternatives may need to be considered to reduce impacts to the farmland. Projects planned and completed without the assistance of a federal agency are not subject to FPPA.

2.2.2 Overview of Georgia State Laws

The more significant state acts with elements that relate to drainage from roadways are listed below with a brief description of the provisions of each act. A timeline presenting the inception dates of the federal and state acts is provided in Figure 2.1.

- **THE GEORGIA WATER QUALITY CONTROL ACT (GWQCA) OF 1964, AMENDED 1972 (OCGA 12-5-20).** This Act provides the structure under which the state of Georgia implements the federal CWA. It works in conjunction with the CWA to deal with waste water discharge, site selection, and wetlands mitigation requirements. It also establishes water quality standards for every body of water in Georgia. The water quality standards include a designated use for each water body, which describes and defines the maximum levels of pollutants that may exist in the water, and an "anti-degradation" statement, which prohibits high quality waters from being degraded. Generally, the standards of NPDES permits issued to municipalities, industries, and other dischargers are sufficiently stringent to ensure that state water quality standards will not be violated by the proposed wastewater discharge.
- **THE GEORGIA COASTAL MANAGEMENT ACT of 1972 (OCGA 12-5-320).** This Act authorized the creation of the Georgia Coastal Management Program (approved by NOAA in 1998). The Coastal Resources Division of the GADNR serves as the administrator of the Program. The Program is a network of federal, state, and local agencies, which work

together to address coastal issues. This network facilitates coordination among agencies, which improves management of coastal resources. The Program was a lead contributor in the creation of the Coastal Stormwater Supplement (CSS) to the Georgia Stormwater Management Manual (GSMM). This CSS represents the culmination of the state's efforts to provide for the implementation of the federally established "management measures" required in order to receive final approval of a Coastal Non-Point Source (NPS) Management Program. This CSS and the Coastal NPS Management Program, seeks to reduce the impacts of land development and nonpoint source pollution in a 24-county region located in southeast Georgia.

- **THE METROPOLITAN RIVER PROTECTION ACT (MRPA) OF 1973 (OCGA 12-5-440).** This act provides special protection to the Chattahoochee River based on the growing threats to the quality of this drinking water supply source. The MRPA established a 2000-foot corridor on both banks of the Chattahoochee between Buford Dam and Peachtree Creek, which was extended to the southern limits of Douglas and Fulton Counties in 1998. It also requires the Atlanta Regional Commission (ARC) to develop and adopt a plan to protect this river corridor from the negative effects of development, such as erosion and sedimentation, increased stormwater runoff, and the pollutants in runoff from developed and impervious areas.
- **THE GEORGIA EROSION AND SEDIMENT CONTROL ACT (GESA) OF 1975, as amended (OCGA 12-7-1), also known as Act 599.** This Act provides protection to Georgia's waters from soil erosion and sediment deposition, primarily originating from land-disturbing activities (clearing, grading, and other construction-related activities). This Act requires that local governing authorities such as counties and incorporated municipalities adopt comprehensive ordinances governing land-disturbing activities within their jurisdictions. The ordinances must contain technical principles as provided in the law and procedures for issuance of permits.

Local jurisdictions failing to have a comprehensive erosion and sediment control program will be subject to rules and regulations developed by the EPD of the GADNR. This division of state government would then issue permits, perform inspections, and become the enforcer for all land-disturbing activities within their boundaries until such time as the local authorities adopt an ordinance.

- **GEORGIA ENVIRONMENTAL POLICY ACT (GEPA) OF 1991 (OCGA 12-16-1).** This Act is analogous to the federal NEPA. It requires the evaluation and disclosure of environmental impacts of proposed state-funded actions and it follows a process similar to that of the NEPA. In the event of a determination of a significant adverse impact, the Act requires an evaluation of the benefits and limitations of alternatives that would avoid the adverse impact as well as measures to minimize harm.
- **THE COMPREHENSIVE STATE-WIDE WATER MANAGEMENT PLANNING ACT of 2004 (OCGA 12-5-520).** This act calls for the GA EPD to prepare a comprehensive water plan and provides fundamental goals and guiding principles for the development of the plan. Georgia will use a rotating basin approach to monitoring, assessment, listing, TMDL development, and NPDES permit reissuance.

2.3 Coordination with Regulatory Agencies

It is the responsibility of GDOT or its consulting roadway drainage and bridge hydraulic engineer to coordinate as early as possible in the project schedule and follow-up diligently with regulatory agencies in order to move a project forward. Active involvement by the engineer and environmental analyst will facilitate inter-agency communication and avoid project delays that may otherwise occur. As further described in section 2.3.3, flowcharts for concept, preliminary plans, and final plans that include coordination efforts with various regulatory agencies can be found within the GDOT Plan Development Process (PDP). [\(2-5\)](#)

When there is more than one reviewing or permitting agency involved, the rules and regulations of the more stringent regulator shall apply. In situations where these agencies or regulators contradict one another, it is the designer's responsibility to resolve the matter, most likely through a joint coordination meeting or similar means.

2.3.1 Federal Agencies

The following are the primary federal agencies having jurisdiction over project resources impacted by roadway drainage:

USCG

<http://www.uscg.mil/hq/cg5/cg551/>

<http://www.uscg.mil/d7/d7dpb/links.asp>

The USCG has regulatory authority under section 9 of the RHA of 1899 to approve plans and issue permits for bridges and causeways across navigable rivers. As outlined in 23 CFR 650, the area of jurisdiction of USCG and FHWA is established as follows.

FHWA has the responsibility under the Federal-Aid Highway Act to determine whether or not a USCG bridge permit is required. This determination should be made at an early stage of project development so that any necessary coordination can be accomplished during environmental permitting.

USCG has the responsibility to do the following: 1) to determine whether or not a USCG permit is required for the improvement or construction of a bridge over navigable waters, except for the exemption exercised by FHWA as stated above, and 2) to approve the bridge location, alignment, and appropriate navigational clearances for all applications made to construct a bridge over a navigable waterway.

If a project involves a navigable waterway, the NEPA analyst must complete a bridge permit questionnaire and submit it to the FHWA for a determination of the need for a USCG permit. If the FHWA indicates that the project will require a USCG permit, the GDOT Office of Bridge Design will prepare and submit the permit application.

According to the USCG Bridge Administration Manual, chapter 2, section I (COMDTINST M16590.5C), bridge permit applicants should be encouraged to conduct waterway surveys as part of the application process to help determine bridge vertical clearance requirements. These surveys will help identify existing and prospective vessels using the waterways that exceed established vertical guide clearances, and possibly require an increased clearance for a planned bridge.

USACE

<http://www.usace.army.mil/>

The USACE has regulatory authority over the construction of dams, dikes, or obstructions other than bridges under section 9 of the RHA of 1899. USACE also has authority to regulate the provisions of section 10 of this Act, which prohibits the alteration or obstruction of any navigable waterway with the excavation or deposition of fill material in such waterway.

Section 404 of the CWA prohibits the unauthorized discharge of dredged or fill material into waters of the United States, including navigable waterways. Such discharges require a Section 404 permit from the USACE.

The USACE grants Nationwide General Permits (NWP) under Section 404 for certain minor activities involving discharge of fill material. NWPs were developed to allow projects that cause minimal adverse impacts to waters of the United States. The NWPs most applicable to roadway drainage are as follows:

- NWP 3 – Maintenance
- NWP 7 – Outfall Structures and Associated Intake Structures
- NWP 13 – Bank Stabilization
- NWP 14 – Linear Transportation Projects
- NWP 15 – USCG Approved Bridges
- NWP 23 – Approved Categorical Exclusions
- NWP 33 – Temporary Construction, Access, and Dewatering
- NWP 41 – Reshaping Existing Drainage Ditches

Additional information regarding NWPs can be found at:

<http://www.usace.army.mil/Missions/CivilWorks/RegulatoryProgramandPermits/NationwidePermits>

Regional General Permits (RGP) are similar to NWPs in that they are programmatic permits. Instead of applying on a national scale, RGPs apply only within specific USACE regions.

Projects that do not meet the criteria for a NWP must apply for an Individual Permit (IP) from the USACE under Section 404 of the CWA. Processing IPs involves evaluation of individual and project-specific applications in what can be considered three steps:

1. Pre-application consultation (for larger projects)
2. Formal permit application review
3. Decision-making

Pre-application consultation usually involves one or several meetings between the applicant, USACE staff, interested resource agencies (federal, state, or local), and sometimes the interested public. Once a complete application is received, the formal review process begins. The USACE prepares a public notice (if required), evaluates the impacts of the project and considers all comments received, addresses potential modifications to the project if appropriate, and drafts or oversees drafting of appropriate documentation to support a recommended permit decision. The permit decision document includes a discussion of the environmental impacts of the project, the

findings of the public interest review process, and any special evaluation required by the type of activity such as determinations of compliance with Section 404(b)(1) of the CWA.

The USACE's "Obtain a Permit" web page is located here:

www.usace.army.mil/Missions/CivilWorks/RegulatoryProgramandPermits/ObtainPermit

This web page provides links to the USACE application form ENG FORM 4345, instructions for filling out the form, and applicable regulations and guidance, which are the legal foundation of the USACE permitting program.

When the USACE determines that an IP is required for a project, GDOT must prepare a Practical Alternatives Report (PAR). The purpose of the PAR is to conduct an analysis of multiple project alternatives and to demonstrate that the preferred or selected project alternative is the least environmentally damaging practicable alternative (LEDPA).

The Fish and Wildlife Coordination Act (FWCA) [16 U.S.C. 661-667e; 48 Stat. 401], as amended, provides authority for the U.S. Fish and Wildlife Service (USFWS) to review and comment on the effects on fish and wildlife of activities proposed to be undertaken or permitted by the USACE.

FHWA

<https://www.fhwa.dot.gov/>

The FHWA is an agency within the U.S. Department of Transportation that administers the Federal-Aid Highway Program in concert with state and local governments. The FHWA supports state and local governments in the financing, design, construction, and maintenance of the nation's highway system and various federally and tribal-owned lands (Federal Lands Highway Program). The FHWA is responsible for ensuring that America's roads and highways continue to be among the safest and most technologically sound in the world.

FHWA has the authority to implement the Section 404 Permit Program (CWA of 1977) for federal-aid highway projects processed under 23 CFR 771.115 (b) as categorical exclusions. This authority was delegated to FHWA by USACE to reduce unnecessary federal regulatory controls over activities adequately regulated by another agency. This permit is granted for projects where the activity, work, or discharge is categorically excluded from environmental documentation because such activity does not have an individual or cumulative significant effect on the human environment.

U.S. EPA

<http://www.epa.gov/>

GDOT projects are coordinated through the EPA, Region 4 office. The EPA is responsible for administration of the CWA and for oversight of the NEPA process. Certain sections of the CWA are regulated by other federal or state agencies while the EPA provides oversight and retains veto authority over the other agencies. Examples include Section 402 and Section 404 of the CWA.

The EPA is authorized to prohibit the use of any area as a disposal site when it is determined that the discharge of materials at the site will have an unacceptable adverse effect on municipal water supplies, shellfish beds and fishery areas, wildlife, or recreational areas (Section 404 (c), CWA, 33 USC 1344). Also, the EPA is authorized under Section 402 of the CWA (33 USC 1344) to administer and issue an NPDES permit for point source and non-point source discharges.

Section 404 of the CWA (33 USC 1344) requires any applicant for a federal permit for any activity that may affect the quality of waters of the United States to obtain a water quality certification from the GA EPD.

USFWS

<http://www.fws.gov/>

The Fish and Wildlife Act (FWA) of 1956 (16 USC 742 et seq.), the Migratory Game-Fish Act (MGFA) (16 USC 760c-760g) and the FWCA (16 USC 611-666c) provide protection of the quality of the aquatic environment as it affects the conservation, improvement, and enjoyment of fish and wildlife resources. The FWCA requires that the USFWS and Georgia Wildlife Resources Division be consulted for review and comment whenever a private or public entity's action proposes to modify or impact a stream or body of water in Georgia. This includes drainage impacts. The intent of the above Acts is to conserve wildlife resources by preventing loss of and damage to such resources as well as provide for the development and improvement of such resources.

It is the function of the USFWS to consider and balance all factors, including anticipated benefits and costs in accordance with NEPA, in deciding whether to issue the permit.

GDOT should initiate contact with the USFWS regarding relevant actions on proposed roadway projects. Refer to the GDOT EPM and PDP for specifics regarding coordination, timing of coordination, and general steps to secure a permit.

USDA

<http://www.usda.gov/>

NRCS

<http://www.nrcs.usda.gov/>

GDOT projects receiving federal aid must be coordinated with the NRCS to determine if there is farmland involvement in accordance with the FPPA. If it is determined that impacted farmland meets the FPPA criteria, GDOT should further coordinate with the NRCS to calculate a Farmland Conversion Impact Rating. Depending on this rating, additional roadway alignment alternatives may need to be considered to reduce impacts to the farmland. Projects planned and completed without the assistance of a federal agency are not subject to FPPA.

Early coordination will be completed with the NRCS regarding impacts to farmland as discussed in the paragraph above.

Refer to the GDOT EPM, chapter V section 5.3, for more detail on required coordination with the NRCS.

TVA

<http://www.tva.gov/>

The TVA was established by the TVA Act of 1933. Section 26a of that Act requires that TVA approval be obtained before any construction activities can be carried out that affect navigation, flood control, or public lands along the shoreline of the TVA reservoirs or in the Tennessee River or

its tributaries. Permit approvals for construction under section 26a are considered federal actions and are therefore subject to the requirements of the NEPA and other federal laws.

Among the typical GDOT structures and projects that require TVA approval under a Shoreline Construction Permit are bridges, culverts, and fill or construction within the floodplain. Section 26a regulations apply to both the location of construction projects and the types of activities carried out.

Note that TVA approval is not required for replacement of culverts or bridges of the same or greater hydraulic capacity, which create no new or additional obstruction and are within the same roadway alignment. This type of construction is considered maintenance activity.

Shoreline Construction Permits are needed for both on-reservoir and off-reservoir activities:

- **On-reservoir activities** are those that occur in, across, or along TVA reservoirs and regulated rivers and streams in the Tennessee Valley. Regulated rivers and streams are located downstream of TVA dams and are directly impacted by the operation of the dams.
- **Off-reservoir activities** are those that occur on all other perennial rivers and streams in the Tennessee Valley watershed. The construction standards outlined on this site do not apply to off-reservoir activities, which are considered on a case-by-case basis.

Detailed information regarding Shoreline Construction Permits under section 26a is available at the following website: <http://www.tva.gov/river/26apermits>

2.3.2 State and Local Agencies

The following are the primary state and local agencies having jurisdiction over project resources impacted by roadway drainage:

GADNR

<http://www.gadnr.org/>

EPD

<http://www.georgiaepd.org/>

The Georgia EPD is the division of the GADNR charged with protecting public health and the environment. The EPD makes buffer determinations on state waters for all streams, wetlands, and open waters on GDOT projects during the concept phase of the project. Once a preferred alignment is identified, the project ecologist will complete an Ecological Assessment of Effects (EAOE) Report and transmit the report along with a request for concurrence with the state waters determinations outlined in the report. If a stream buffer variance is required, the Georgia EPD is responsible for review and approval of the variance application.

Further, the Georgia EPD is the state agency responsible for administration and enforcement of the federal NPDES program within the state of Georgia. NPDES Permit no. GAR041000 covers all new and existing point source discharges of stormwater from an MS4 owned and/or operated by GDOT to the waters of the state of Georgia, except for those stormwater discharges identified under Part 1.1.5 of the Permit (GAR041000). The use of certain post-construction BMPs for attenuating stormwater runoff and meeting specified water quality standards for discharge of stormwater from roadways is required by the permit.

Refer to chapter 9 of this manual for information on BMPs that may be implemented during construction of roadway drainage systems to reduce and control impacts to the environment as a result of land disturbance and construction activities.

The GAR041000 NPDES permit is available for download here:

[http://www.dot.ga.gov/PartnerSmart/DesignManuals/PolicyAnnouncements/NPDES%20General%20Permit%20GAR041000%20\(2-21-17\).pdf](http://www.dot.ga.gov/PartnerSmart/DesignManuals/PolicyAnnouncements/NPDES%20General%20Permit%20GAR041000%20(2-21-17).pdf)

The highway engineer and ecologist shall refer to the GDOT EPM for federal and state actions requiring involvement or approval of the EPD and detailed procedures for coordinating with the EPD. For additional general information regarding the Georgia EPD, go to <http://www.georgiaepd.org/>.

Coastal Resources Division (CRD)

<http://www.coastalgadnr.org/>

The CRD is a division within the GADNR. The CRD is responsible for implementing the Georgia Coastal Management Program (GCMP) and is involved in Section 404 permitting with the USACE in certain coastal counties. The CRD determines the marsh jurisdictional line and is also the permitting authority for saltwater buffer encroachments. Refer to the GDOT EPM for detailed information on coordinating with the USACE and CRD regarding review of the Pre-Construction Notification and concurrence of the GCMP with the federal consistency certification. For more information regarding the Georgia CDR, go to <http://www.coastalgadnr.org/>.

GSWCC

<http://gaswcc.georgia.gov/>

The GSWCC was formed to protect, conserve, and improve the soil and water resources of the state of Georgia. In 2003, under Georgia House Bill 285, the GSWCC was charged with administering and managing erosion control education and certification programs for individuals involved in land-disturbing activities.

The GSWCC publishes and maintains the Manual for Erosion and Sediment Control in Georgia, also known as “The Green Book”. The Green Book was assembled to provide guidance in the implementation of Act 599. It provides detailed information on the design and installation of temporary structural and vegetative BMPs that may be used to control erosion and sedimentation during land-disturbing activities in the state of Georgia. The criteria, standards, and specifications contained in chapter 6 of The Green Book must be incorporated into all local erosion and sediment control programs. The BMPs contained in this manual correspond to those required under the Georgia NPDES permits to provide required erosion and sediment controls.

Erosion and sediment control plans for GDOT projects shall be designed in accordance with The Green Book and with chapter 9 of this manual.

Georgia Regional Commissions

Per the GDOT EPM, an Early Coordination Letter should be sent to the appropriate regional commission for proposed roadway projects. Letters to regional commissions should include a request for information concerning low income and minority communities. The project engineer

should coordinate with the applicable regional commission to determine if particular drainage requirements are requested for roadway projects within that region. For contact information, use the website link, <http://garc.ga.gov/>. A map showing counties within each regional commission's jurisdiction is presented in Figure 2.2.

Regional commissions requiring coordination include the following:

- Region 01 - Northwest Georgia (<http://www.nwgrc.org>)
- Region 02 - Georgia Mountains (<http://www.gmrc.ga.gov>)
- Region 03 - Atlanta Regional Commission (<http://www.atlantaregional.com>)
- Region 04 - Three Rivers (<http://www.threeriversrc.com>)
- Region 05 - Northeast Georgia (<http://www.negrc.org>)
- Region 06 - Middle Georgia (<http://www.middlegeorgiarc.org>)
- Region 07 - Central Savannah River Area (<http://www.csrarc.ga.gov>)
- Region 08 - River Valley (<http://www.rivervalleyrc.org>)
- Region 09 - Heart of Georgia Altamaha (<http://www.hogarc.org>)
- Region 10 - Southwest Georgia (<http://www.swgrc.org>)
- Region 11 - Southern Georgia (<http://www.sgrc.us>)
- Region 12 - Coastal (<http://www.crc.ga.gov>)

The development of the GSMM was facilitated by the Region 3 - Atlanta Regional Commission (ARC). The GSMM is the basis for the post-construction BMPs presented in this manual and specified in the NPDES Permit No. GAR041000.

Water Planning Regions

The project engineer or ecologist shall consider the water planning region in which a given project is located. A map of the state of Georgia water planning regions is presented in Figure 2.3. It should be determined whether or not there are any special stormwater related ordinances or discharge limits that GDOT should strive to comply with when designing and constructing drainage systems for the project.

- Altamaha (<http://www.altamahacouncil.org>)
- Coastal Georgia (<http://www.coastalgeorgiacouncil.org>)
- Coosa - North Georgia (<http://www.coosanorthgeorgia.org>)
- Lower Flint - Ochlockonee (<http://www.flintochlockonee.org>)
- Metropolitan North Georgia Water Planning District (MNGWPD) (<http://www.northgeorgiawater.com>)
- Middle Chattahoochee (<http://www.middlechattahoochee.org>)
- Middle Ocmulgee (<http://www.middleocmulgee.org>)
- Savannah - Upper Ogeechee (<http://www.savannahupperogeechee.org>)
- Suwannee - Satilla (<http://www.suwanneesatilla.org>)
- Upper Flint (<http://www.upperflint.org>)
- Upper Oconee (<http://www.upperoconee.org>)

Figure 2.3 - State of Georgia water planning regions map
Reference: Georgia Comprehensive State-wide Water Management Plan

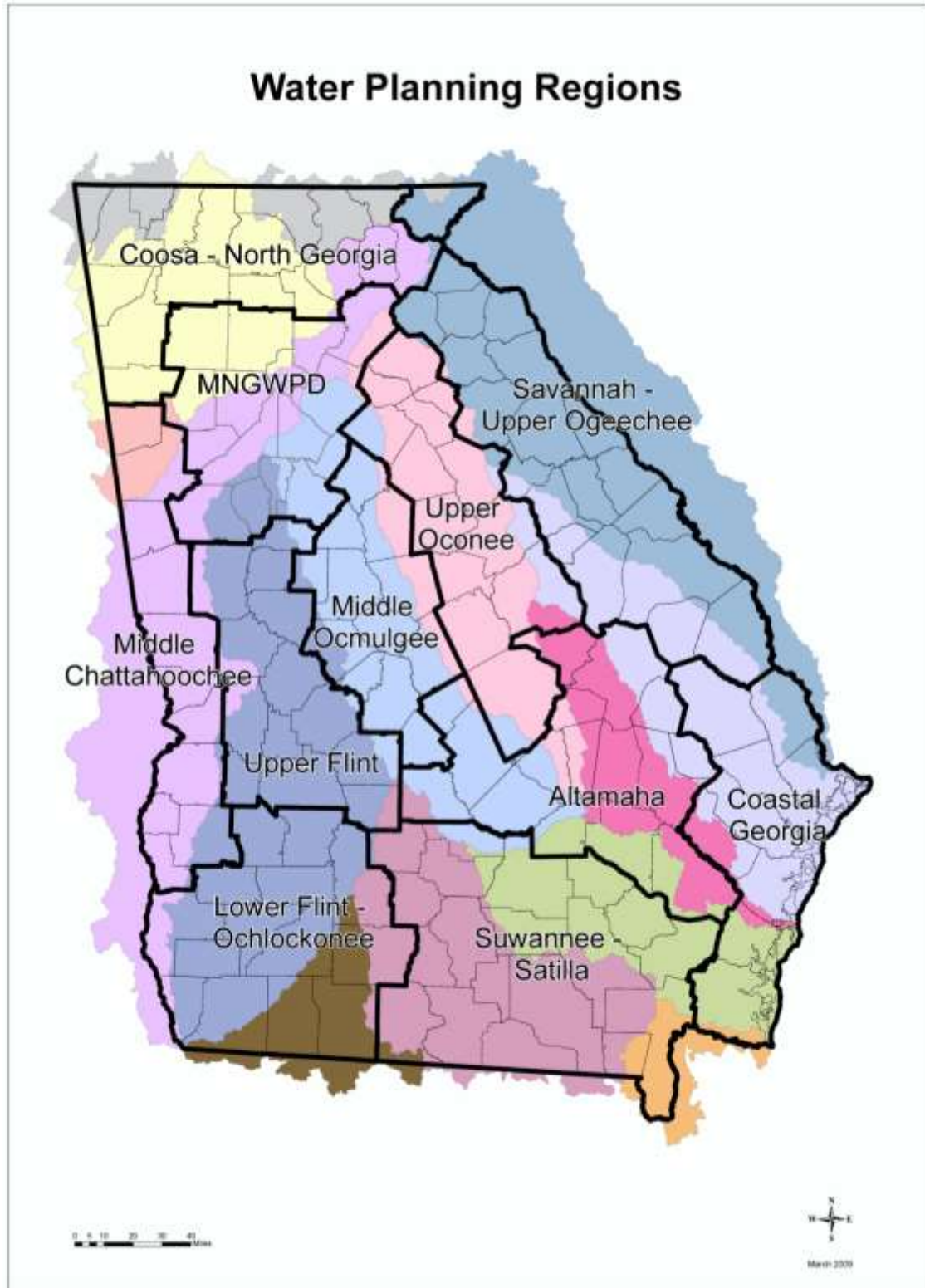

Etowah Aquatic Habitat Conservation Plan (HCP)

(<http://www.etowahhcp.org/>)

The Etowah Aquatic HCP stormwater management policies emphasize infiltration and the use of "better site design" and low-impact development (LID) techniques within the Etowah River basin. The Stormwater Runoff Limits program requires that, in the most sensitive watersheds, the volume of runoff from new development must match that of the site in an undeveloped, forested condition. For less sensitive watersheds and designated development nodes within the Etowah basin, the allowable runoff limits are higher.

The HCP Stream Buffer Protection Ordinance is based upon that of the Metropolitan North Georgia Water Planning District (MNGWPD), with additional requirements to safeguard imperiled species.

The design, sizing, and installation of culverts and bridges affect the imperiled aquatic species covered by the HCP. The HCP Stream Crossing and Culvert Design Policy provides guidelines for the design of road crossings based on the ecosystem needs of the covered species within the Etowah basin.

2.3.3 Coordination Process Flow

The following sources provide valuable guidance on the flow of regulatory coordination that must take place during the development of a project from inception to project letting:

- "Generalized Plan Development Process (PDP) Flow for Major Projects", GDOT PDP Manual, chapter 3, page 28
- GDOT PDP Flow Charts for Concept, Preliminary Plans, and Final Plans, downloadable here: <http://www.dot.ga.gov/PS/DesignManuals/DesignGuides>
- "Timeline of NEPA activities for Categorical Exclusions and Environmental Assessments/Finding of No Significant Impacts", GDOT EPM, chapter 1, section 5.0, page 10
- "The NEPA Process", A Citizen's Guide to NEPA, page 8
- "NEPA Process Flow Chart" downloadable here: http://www.fhwa.dot.gov/planning/tpr_and_nepa/planningnepaflowchart.cfm

In addition to the above flow charts, roadway project team members shall review the GDOT PDP, particularly chapters 3, 5, and 6 and the GDOT EPM for further guidance on regulatory compliance and coordination with federal and state agencies.

2.4 NFIP

(<http://www.fema.gov/national-flood-insurance-program>)

Given the significance and number of river crossings and floodplain-related issues encountered during roadway construction, specific information and guidance related to the FEMA regulations and requirements is provided. The information below is based on GDOT policy and practice.

2.4.1 Flood Insurance

The National Flood Insurance Act of 1968, as amended, (42 USC 4001-4127) requires that communities adopt adequate land-use and control measures to qualify for insurance. Federal criteria promulgated to implement this provision contain the following requirements that can affect certain roadways:

For riverine situations, when the Federal Insurance Administration has identified a flood-prone area without a designated floodway, the community must regulate the floodplain until a floodway has been established. Land-disturbing activities such as fill shall not be permitted within the floodplain in which base flood elevations have not yet been provided, unless the effect of the proposed use, when combined with all other existing and reasonably anticipated uses of a similar nature, will not increase the water surface elevation of the 100-year flood to more than the local ordinance requirement at any point within the community.

After the floodplain special flood hazards, the 100-year water surface elevations, and floodway data have been provided, the community must designate a floodway which will convey the 100-year flood without increasing the water surface elevation of the flood to more than the local ordinance requirement at any point and prohibit, within the designated floodway, fill, encroachments, and new construction and substantial improvements of existing structures that would result in any increase in flood heights within the community during the occurrence of the 100-year flood discharge.

The participating cities and/or counties agree to regulate new development in the designated floodplain and floodway through regulations adopted in a floodplain ordinance. The ordinance requires that development in the designated floodplain be consistent with the intent, standards and criteria set by the NFIP.

2.4.2 Flood Disaster Protection

The Flood Disaster Protection Act of 1973 (PL 93-234, 87 Stat. 975) denies federal financial assistance to local communities that fail to qualify for flood insurance. Formula grants to states are excluded from the definition of financial assistance, and the definition of construction in the Act does not include roadway construction; therefore, federal aid for highways is not affected by the Act. The Act does require communities to adopt certain land-use controls to qualify for flood insurance as described in section 2.6.1. These land-use requirements could impose restrictions on the construction of roadways in floodplains and floodways in communities which have qualified for flood insurance.

2.4.3 Local Community

The local community with land-use jurisdiction, whether it is a city, county, or state, has the responsibility for enforcing NFIP regulations in that community if the community is participating in the NFIP. Consistency with NFIP standards is a requirement for federal-aid highway actions involving regulatory floodways. The community, by necessity, is the entity that must approve and sign proposals to FEMA for amendments to NFIP ordinances and maps in that community. GDOT and its consultants shall coordinate directly with the community and, through them, coordinate with FEMA. Determination of the status of a community's participation in the NFIP and the review of applicable NFIP maps and ordinances are, therefore, essential first steps in conducting location hydraulic studies and preparing environmental documents.

2.4.4 NFIP Maps

Where NFIP maps are available, their use is mandatory in determining whether a roadway location alternative will include an encroachment on the base floodplain. The following four types of NFIP maps are published in Georgia:

- Flood Insurance Rate Maps (FIRM)
- Digital Flood Insurance Rate Maps (DFIRM)
- Flood Boundary and Floodway Maps (FBFM)
- Flood Hazard Boundary Maps (FHBM)

A FIRM is generally produced at the same time using the same hydraulic model and has appropriate rate zones and base flood elevations added. A DFIRM is an electronic product linked to a geographical information system (GIS) database. It includes the same information as a FIRM but can include additional information as well, such as hydraulic structure data. An FBFM delineates both the areas of special flood hazards and the floodway. An FHBM indicates where the boundaries of the flood, mudslide, and related erosion areas having special hazards have been designated.

Communities may or may not have published one or more of the above maps depending on their level of participation in the NFIP. Information on community participation in the NFIP is provided in the *National Flood Insurance Program Community Status Book*, which is published semiannually for each state.

2.5 NFIP Requirements

All floodplain crossings must comply with FEMA regulations. GDOT adheres to the guidelines set forth in the FHWA's Federal-Aid Policy Guide, 23 CFR 650A, September 30, 1992, Transmittal 5, "Procedures for Coordinating Highway Encroachments on Floodplains with Federal Emergency Management Agency." A copy of this policy guide is included in [appendix B](#) of this manual.

2.5.1 FEMA Coordination

GDOT coordination with FEMA may arise in situations where administrative determinations are needed involving a regulatory floodway or where flood risks in NFIP communities are significantly impacted. The circumstances which would ordinarily require coordination with FEMA include the following:

- When a proposed crossing encroaches on a regulatory floodway and would require a revision to the floodway map,
- When a proposed crossing encroaches on a floodplain where a detailed study has been performed but no floodway designated and would require a revision to the floodway map,
- When a local community is expected to enter into the regular program within a reasonable period and detailed floodplain studies are under way,
- When a local community is participating in the emergency program and base FEMA flood elevation in the vicinity of insurable buildings is increased by more than 1 foot., or

- Where insurable buildings are not affected, it is sufficient to notify FEMA of changes to base flood elevations as a result of highway construction.

The draft EIS/CE/EA should indicate the NFIP status of affected communities, the encroachments anticipated, and the need for floodway or floodplain ordinance amendments.

Coordination means furnishing the draft EIS/EA to FEMA. Upon selection of an alternative, coordination would also include furnishing the following information to FEMA through the community: a preliminary site plan, water surface elevation information, and any technical data in support of a floodway revision request as required. If a determination by FEMA would influence the selection of an alternative, a commitment from FEMA should be obtained prior to the final environmental impact statement (FEIS) or a FONSI through a conditional map revision request. Otherwise, this later coordination may be postponed until the design phase. The designer should be aware that projects processed with a CE provide coordination during design. The outcome of the coordination could change the class of environmental processing. For additional information on map revisions, see section 2.8 of this chapter.

For sites located within a FEMA regulatory floodway, the consultant is responsible for sizing a drainage structure that meets the standards and approval of GDOT, the affected community, and FEMA. The consultant shall provide the necessary forms, floodway and flood profile computer runs, and other supporting documentation as required for approval.

Note: The consultant may be required, at the Department's discretion, to coordinate directly with the affected community and/or FEMA as necessary. All supporting documentation, along with copies of correspondence and approvals from the community and FEMA shall be provided to GDOT for its records and use.

For state-aid projects, where the consultant has done a hydraulic study for the community, the consultant, at a minimum, shall provide GDOT with a copy of a Letter of Concurrence from the community and approval from FEMA (if required).

2.5.2 Longitudinal Roadway Encroachments

Since longitudinal floodplain and floodway encroachments by new and widened roadways generally have a major effect on the flood elevations of the affected stream, these encroachments shall be avoided if at all possible. The project manager and location engineer shall abide by the following basic rules for roadway widening, dualizations, and new locations:

1. For roadway-widening projects, the typical section shall be set to avoid or minimize the placing of additional roadway fill within the adjacent floodplain.
2. For roadway paralleling projects, the new parallel roadway shall be placed to avoid or minimize longitudinal encroachments on floodplains.
3. New location roadway projects shall be aligned to avoid or minimize longitudinal encroachments on floodplains.
4. For all cases, longitudinal encroachment on a delineated FEMA regulatory floodway shall be avoided if at all possible.

2.5.3 Categories and Recommendations for Bridges and Culverts

All bridges within the state fall into one of the following five categories concerning FEMA involvement. All culverts fall within categories two through five.

1. If the stream has an established regulatory floodway, the structure should be designed, if practical, so that the bridge approaches will not encroach on the regulatory floodway. The bridge superstructure should also clear the floodway elevation. The bridge substructure is considered, in most cases, to be an insignificant encroachment. If the design keeps the bridge approach out of the floodway and the low chord above the floodway elevation, the affected community shall be sent a copy of the proposed roadway plans and the preliminary bridge layout along with a letter stating that the proposed construction will not encroach on the regulatory floodway, and a request for a "letter of concurrence" from the community, approving the project. If an exceptionally large pier is to be constructed in the floodway, especially at a new crossing, it may be necessary to treat the bridge under category 2 or 3 below. Also, if the project is located within a high risk area as determined by the hydraulic engineer, it may be necessary to treat the bridge under category 2 or 3 below.
2. If the stream has an established regulatory floodway, and encroachment on the regulatory floodway is necessary, the structure should be designed, if practical, so that there will be no change in the base flood elevations, floodway elevations, or floodway widths at any cross section. GDOT defines a "No-Rise" project as one that causes no change in the base flood profile or the floodway profile rounded to the nearest 0.1 foot or in floodway width rounded to the nearest 1 foot for any cross section outside the Department's right-of-way. Changes greater than 0.1 foot in the base flood profile or the floodway profile and/or 1 foot in the floodway width inside the right-of-way are considered integral to the bridge structure and do not affect any other property.

For consultant projects, a signed and sealed "No-Rise" certification by a registered professional engineer is required (see [appendix B](#) at the end of this manual). If this criterion is met, two original sets of supporting documentation shall be prepared. One set is for submission to the affected community, requesting a "letter of concurrence" approving the project to be sent to GDOT. One set will be retained in the project file for GDOT's records.

An example of a "No-Rise" condition can be shown in either of the two following cases for the floodway elevation:

1. When the total difference in the calculated floodway elevations at a section is 0.05 foot or less. An example of a "No-Rise" for this condition is a comparison of the elevations 100.98 and 100.93 feet. Once water surface elevations exceed 0.05 foot, then a no-rise condition can no longer be claimed according to GDOT. The designer should note that some local communities have more stringent regulations, such as not increasing at all (0.00 feet).
2. When the calculated floodway elevations are the same after rounding these elevations to the nearest 0.1 foot. An example of this condition is a comparison of the elevations 100.04 and 99.96 feet. Since both these elevations round off to 100.0 feet, this is considered a "No-Rise" condition as defined by GDOT. The designer should again note that some local communities have more stringent regulations, such as not increasing at all (0.00 feet).

The comparison of floodway widths is similar to the above two cases involving the floodway elevation.

3. If the stream has an established regulatory floodway, and an encroachment on the regulatory floodway is necessary, and the criteria of category 2 are not met, then the affected community will need to make arrangements and obtain approval from any affected property owners. The community will also be responsible for coordinating with FEMA to revise the effective base flood elevations, floodway widths, and floodway elevations. Revisions such as these often require local funding that may not be available, further coordination will be required by GDOT and the local community on a project-specific basis to prepare the necessary map revisions. See section 2.8 of this chapter for additional information.

For consultant projects, the Professional Certification Form required by FEMA shall be completed, stamped, and signed by a registered professional engineer (see [appendix B](#) at the end of this manual). For cases such as these, GDOT requires three original sets of supporting documentation be prepared. Two sets are for submission to the affected community, requesting a "letter of concurrence" to be sent to FEMA and copied to GDOT. One set will be retained in the project file for GDOT's records. The community's "letter of concurrence" approves the project as designed along with the proposed revision to the base flood elevations, floodway elevations, and floodway widths. It is the responsibility of the designer to adhere to either GDOT design policy or the local floodplain ordinances, if they are determined to be more stringent.

4. For a bridge crossing a floodplain that is shown on a FIRM map, but does not have a regulatory floodway, the bridge will be sized to limit the backwater to no more than a 1-foot increase in the existing base flood elevation, unless the local community's ordinances are more stringent. In which case, the local regulation shall apply.
5. For bridges that are outside of NFIP communities or NFIP identified flood hazard areas, the bridge shall be sized using the GDOT design criteria and requirements (see chapter 12).

2.6 Design Data Required for Project Involving FEMA Floodplains

2.6.1 Publications

FEMA regulatory information can be obtained by visiting their Map Service Center Web site at <https://msc.fema.gov>.

2.6.2 Maps

1. FIRM
2. DFIRM
3. FBFM
4. FHBM
5. Detailed Study Workmaps. These are large-scale topographic maps annotated with cross-section locations, floodplain limits, and floodway boundaries from detailed hydraulic studies.

2.6.3 Survey Data, Plans, Reports

1. All data specified on the Hydraulic Engineering Field Report. This report contains a detailed listing of the minimum survey data that is required (see [appendix B](#) in this manual). The hydraulic engineer shall determine the extent of survey data required to accurately model the project site.
2. CAiCE (digital/electronic) survey files.
3. Existing bridge and roadway plans.
4. Three sets of preliminary proposed roadway plans.

2.6.4 Regulations and Policy Guides

1. Federal-Aid Policy Guide, NS 23 CFR 650A, "Procedures for Coordinating Highway Encroachments on Floodplains with Federal Emergency Management Agency (FEMA)." See [appendix B](#) in this manual.
2. The NFIP laws and regulations are available for download at <http://www.fema.gov/national-flood-insurance-program/laws-and-regulations>.

2.6.5 Computer Models and Manuals

For current hydrologic and hydraulic computer models that meet the minimum requirements of the NFIP, please visit the FEMA web site at <http://www.fema.gov/national-flood-insurance-program-flood-hazard-mapping/hydrologic-models-meeting-minimum-requirement>.

2.7 Design Methods/Procedures for all Encroachments

For current design methods and procedures for all encroachments, please visit the FEMA web site at <http://www.fema.gov/library/viewRecord.do?id=2206> for the FEMA Guidelines and Specifications Volume 2: Map Revisions and Amendments.

2.8 NFIP Map Revisions

FEMA has established administrative procedures for changing or correcting effective FIRMs and Flood Insurance Study (FIS) reports based on new or revised technical data. A physical change to the affected FIRM panels and portions of the FIS report is referred to as a Physical Map Revision (PMR).

A PMR is an official republication of a community's NFIP map to reflect changes to base flood elevations, floodplain boundary delineations, regulatory floodways and planimetric features. These changes typically occur as a result of structural works or improvements, annexations resulting in additional flood hazard areas, or corrections to base flood elevations or Special Flood Hazard Areas (SFHAs).

Changes to NFIP maps may also be made by a Letter of Map Change (LOMC). The three LOMC categories are described below:

- **LETTER OF MAP AMENDMENT (LOMA).** A LOMA is an official revision by letter to an effective NFIP map. A LOMA results from an administrative procedure that involves the review of scientific or technical data submitted by the owner or lessee of property who

believes that the property has incorrectly been included in a designated SFHA. A LOMA amends the currently effective FEMA map and establishes that a specific property is not located in an SFHA.

- **LETTER OF MAP REVISION BASED ON FILL (LOMR-F).** A LOMR-F is an official revision by letter to an effective NFIP map. A LOMR-F states FEMA's determination concerning whether a structure or parcel has been elevated on fill above the base flood elevation and is, therefore, excluded from the SFHA.
- **LETTER OF MAP REVISION (LOMR).** A LOMR is an official revision to the currently effective FEMA map. It is used to change flood zones, floodplain and floodway delineations, flood elevations, and planimetric features. All requests for LOMRs should be made to FEMA through the chief executive officer of the community, because it is the community that must adopt any changes and revisions to the map. If the request for a LOMR is not submitted through the chief executive officer of the community, evidence must be submitted that the community has been notified of the request.

2.8.1 Conditional Letter of Map Revision (CLOMR)

NFIP maps must be based on existing, rather than proposed, conditions. Because flood insurance is a financial protection mechanism for real-property owners and lending institutions against existing hazards, flood insurance ratings must be made accordingly. However, communities, developers, and property owners often undertake projects that may alter or mitigate flood hazards and would like FEMA's comment before constructing them. A CLOMR is FEMA's formal review and comment on whether a proposed project complies with the minimum NFIP floodplain management criteria. If it is determined that it does, the CLOMR also describes any eventual revisions that will be made to the NFIP maps upon completion of the project.

Obtaining conditional approval is not automatically required by NFIP regulations for all projects in the floodplain. A CLOMR is required only for those projects that will result in an increase in the water surface elevation greater than 1 foot for the 100-year flood for streams with base flood elevations specified but no floodway designated. A CLOMR is also required for any proposed construction within a regulatory floodway that will result in an increase in the water surface elevation for the base flood. Note that a CLOMR may also be necessary if there is a decrease in flood elevations, which would allow the community to build in areas previously not allowed. The technical data needed to support a CLOMR request generally involve detailed hydrologic and hydraulic analyses and are similar to the data needed for a LOMR request. When the proposed construction is completed, a LOMR request should be made.

A request for a CLOMR by a private individual, including homeowners and land developers, or by any public agency, must be made through the local community participating in the NFIP. The following are reasons why the CLOMR request is made through the community:

- Community must be aware of changes by the proposed project and determine if they are consistent with local ordinances.
- Community will collect fees for FEMA that apply to requests for map revisions.

- Community must determine that the existing FIRM is not accurate and that the hydrologic and/or hydraulic information should be updated as proposed in the CLOMR request.

Chapter 2 References

1. American Association of State Highway and Transportation Officials (AASHTO). 2007. Highway Drainage Guidelines, 4th Ed.
2. American Association of State Highway and Transportation Officials (AASHTO). 2005. Model Drainage Manual, 3rd Ed.
3. Federal Highway Administration (FHWA), Federal-Aid Policy Guide. "Highways." [Title 23 Code of Federal Regulations \(CFR\)](#).
4. Georgia Department of Transportation (GDOT). 2012. [Environmental Procedures Manual](#)
5. Georgia Department of Transportation (GDOT). 2011. [Plan Development Process – 2000 \(PDP\)](#). Policies and Procedure 4050.

Intentionally Left Blank

Chapter 3. Stormwater Planning - Contents

- Chapter 3. Stormwater Planning - Contents3-i
- 3.1 Introduction.....3-1
- 3.2 Objectives and Conceptualization3-1
- 3.3 Project Workflow and Design Considerations3-2
 - 3.3.1 Sources of Information3-2
 - 3.3.2 Hydrology and Hydraulic Design3-3
 - 3.3.3 Construction Stormwater3-3
 - 3.3.4 Post-Construction Stormwater3-4
 - 3.3.5 Low Impact Development and Green Infrastructure Practices3-5
- 3.4 Project Requirements3-6
 - 3.4.1 GDOT Policy3-6
 - 3.4.2 Project Documentation3-8
 - 3.4.3 Permitting and Other Agencies3-9
- Chapter 3 References.....3-11

Chapter 3. Stormwater Planning

3.1 Introduction

For many reasons, stormwater planning is an essential component of the overall project design. Planning minimizes safety hazards on roadways, the degradation of receiving waters, and adverse impacts to the environment. To effectively plan for the stormwater component of a linear GDOT roadway project, it is important to consider stormwater in the earliest stages of the design process. This chapter contains an overview of the stormwater planning and design process. In accordance with GDOT policies, necessary for both construction and post-construction stormwater measures.

3.2 Objectives and Conceptualization

The main objective of stormwater planning has traditionally been to provide a safe driving environment by preventing stormwater from ponding on roadway surfaces, which can cause vehicles to hydroplane. In addition to public safety concerns, the protection of property upstream and downstream of a GDOT project or facility is also a vital concern. Although the public's safety is the primary concern, stormwater planning is also important for the following two reasons:

- Protection of the GDOT linear facility itself and the function it serves by reducing erosive damage from stormwater discharges
- Protection of the surrounding environment from potentially adverse impacts (e.g., harm to receiving waters, ecosystem, and/or wildlife)

Stormwater that discharges from GDOT owned and operated infrastructure facilities is regulated by the Georgia EPD through GDOT's Municipal Separate Storm Sewer System (MS4) NPDES permit. This permit requires GDOT, and subsequently their consultants, to meet specific requirements within an MS4 area. More information on MS4 permit requirements and a map of MS4 permitted areas can be found in chapter 10 of this manual.

An important part of the GDOT project conceptualization phase is to consider stormwater and how to incorporate it into the planning process. Geometric elements are set based on notational guidance and other GDOT criteria. Priority should be taken to address safety, capacity, mobility, and drainage. After this has been decided water quality will then be addressed. Stormwater planning often requires advanced gathering of data to create alternatives and present viable cost estimates. The following are some key concepts to consider:

- **Avoidance:** avoid disturbing environmentally sensitive areas (e.g. changing the roadway alignment to avoid these areas)
- **Minimization:** minimize the disturbance required for the project (e.g. selecting a bridge design that would minimize floodplain impacts)
- **Footprint Reduction:** reduce the roadway footprint by considering different alternatives (e.g. reducing the number of lanes, reducing lane width, etc.)

A concurrent process to the stormwater planning and conceptualization phase is defining the project scope. During the scope development, awareness of potential stormwater impacts leads to

a better project concept and overall design. The stormwater design workflow process in its entirety is discussed in the next section.

3.3 Project Workflow and Design Considerations

An outline of the project development process, from inception through construction award, can be found in the GDOT’s Plan Development Process (PDP) manual, (3-3) available on its website (<http://www.dot.ga.gov/PartnerSmart/DesignManuals/PDP/PDP.pdf>). Stormwater planning starts at the Concept stage as shown in the [MS4 PDP Flowchart](#).

In addition to following the PDP, stormwater planning should consider other requirements set forth by GDOT. To address these requirements, the designer should approach stormwater planning as shown in Figure 3.1. The lighter shaded top row indicates steps taken during the Concept Stage, where the other darker shaded rows below represent the Preliminary Design Stage. New design alternatives and iterations of layouts may be necessary to address all requirements.

Figure 3.1 Stormwater planning workflow

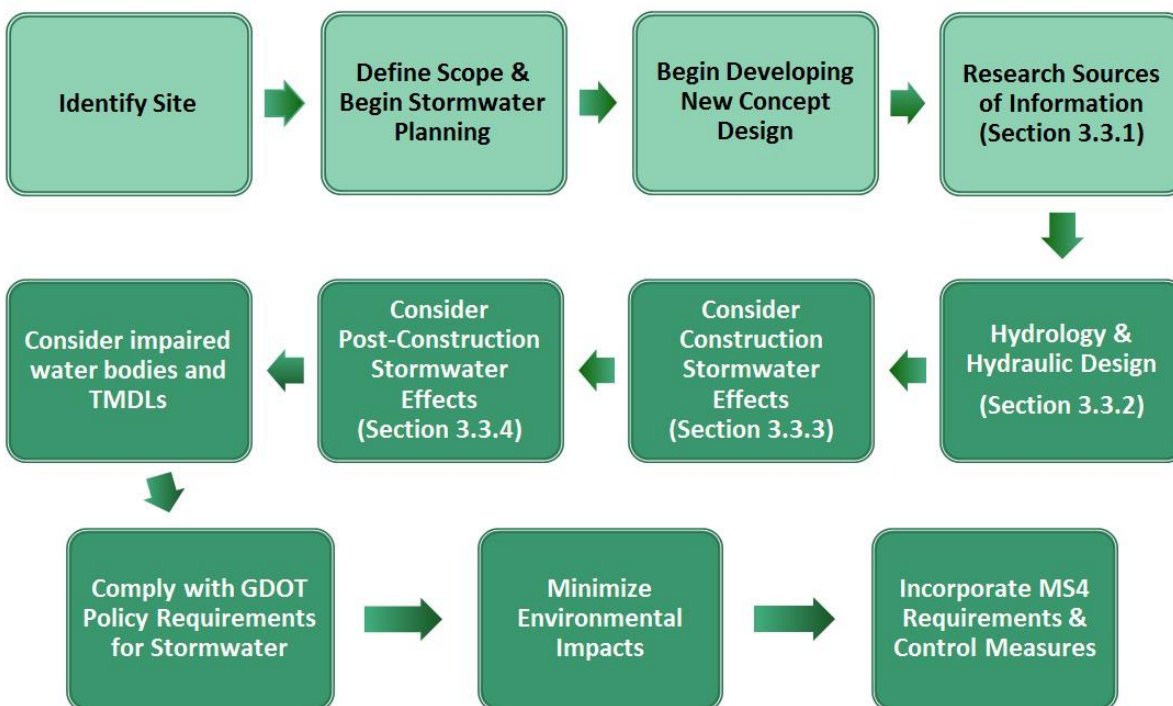

Figure 3.1 is intended as a guidance tool and should be used in conjunction with the MS4 PDP Flowchart and appropriate checklists (from chapter 10) for design requirements found throughout this manual.

3.3.1 Sources of Information

Stormwater planning will often incorporate local, state, and/or federal regulatory requirements.

Information will be needed to fulfill certain regulatory planning aspects and may include the following sources:

- Flood plain data
- United States Geological Survey (USGS) maps
- State, county, or city maps
- Land surveys
- Geotechnical evaluations and soil surveys
- Wetland maps
- Utility companies
- Aerial photography
- Past project plans
- Other nearby projects
- Current approved 303d/305b list

Refer to chapter 2 of this manual for agency coordination requirements.

3.3.2 Hydrology and Hydraulic Design

After gathering the information required for the design process to begin, the project area's hydrology must be determined. GDOT's design policy gives guidance on the hydrologic design method used for each stormwater component. For example, the rational method is used for gutter spread calculations and Technical Release (TR)-55 methodologies are used for post-construction stormwater BMPs. Tables 4.1 and 4.2 in chapter 4 of this manual include a comprehensive list of acceptable design methods and their limitations.

GDOT design policy also gives guidance on determining design flow rates based on specific storm events. Tables 6.3, 7.1, and 8.2 provide design storm events used for pavements, storm sewer and cross drains. Chapter 12 provides a summary of design storm events used for bridges.

Once the hydrologic components of the project are determined, hydraulics of storm sewer systems, culverts, and channels can be evaluated. Additional guidelines and hydraulic design parameters can be found in chapters 5, 6, 7, and 8 of this manual.

Several stormwater design alternatives will develop as the project design progresses. Within the alternative analysis process, it is important to consider both construction stormwater and post-construction stormwater effects. Making stormwater alterations in the project design usually entails numerous modifications to the overall project (e.g., grading, utility coordination, roadway alignment, etc.) For this reason, GDOT urges the designer to consider these planning aspects early in the concept phase.

3.3.3 Construction Stormwater

Construction stormwater refers to runoff that occurs during construction from storm events. This associated runoff can be problematic and contribute to the impairment of Georgia's streams, rivers, and lakes. Currently, the NPDES permit program operating under the Clean Water Act regulates the discharge of pollutants to waters of the United States. As previously noted, low impact development (LID) and minimization strategies help alleviate the effects of construction stormwater runoff. For additional information on erosion control measures and permitting requirements, see chapter 9 of this manual and the Manual for Erosion and Sediment Control in Georgia. [\(3-6\)](#)

Interception and concentration of overland flow and constriction of natural waterways from linear highway construction inevitably results in increased erosion potential. To protect the highway and adjacent areas from erosion, it is sometimes necessary to employ an energy dissipating device, as shown in Figure 3.2.

Figure 3.2 - Typical riprap energy dissipator [\(3-5\)](#)



Energy dissipators should be considered part of the larger design system, which may include the culvert and channel protection requirements (upstream and downstream), and possibly a debris control structure. The interrelationship of these various components must be considered in designing any one part of the system. For example, energy dissipator requirements may be reduced, increased, or possibly eliminated by changes in the culvert design, and the downstream channel conditions (velocity, depth, and channel stability) will impact the selection and design of appropriate energy dissipation devices.

Throughout the design process, the designer should keep in mind that the primary objective is to protect the highway structure and adjacent area from excessive damage due to erosion. One way to accomplish this objective is to return flow to the downstream channel in a condition that approximates the natural flow regime. Note that this implies guarding against employing energy dissipation devices that reduce flow conditions substantially below the natural or normal channel conditions. If an energy dissipator is necessary, the first step should be consideration of possible ways of modifying the outlet velocity or erosion potential. This could include modifying the culvert barrel. If an internal modification is not cost effective or is hydraulically unacceptable, the designer must begin the process of selecting and designing an appropriate external energy dissipation device. Several factors involved in designing an energy dissipator can be found in chapters 5 and 8 of this manual. For a more comprehensive discussion of energy dissipator design, refer to the FHWA publication HEC-14. [\(3-7\)](#)

3.3.4 Post-Construction Stormwater

Post-construction stormwater consists of the permanent controls and practices established to reduce and treat stormwater pollution from stabilized areas. Both poor runoff quality and runoff quantity can have adverse effects on receiving waters, making it important to continually treat and minimize stormwater after construction has been completed. Beginning in 2012, GDOT has been required to meet the permit requirements created as part of the MS4 NPDES permit. Refer to the [PDP Manual](#) and [MS4 PDP Flowchart](#) to see how the MS4 post-construction stormwater requirements fit into the project development process. Chapter 10 of this manual provides a detailed explanation on the allowable permanent controls and design criteria for post-construction practices related to the MS4 permit. In addition to the MS4 permit requirements, Chapter 10 also

discusses the post-construction stormwater detention policy for all projects, regardless of MS4 requirements.

Figure 3.3 - Typical post-construction BMP - grass filter strip [\(3-5\)](#)



The MS4 NPDES permit requires that water quality and the treatment of post-construction stormwater runoff be calculated and documented as part of the design process for projects located within MS4 areas. See chapter 10 of this manual for information on the MS4 coverage area as well as required calculation methods.

Specific BMPs have been selected and preapproved for use by GDOT. Two of these are illustrated in Figures 3.3 and 3.4. This list has been prepared in order of cost effectiveness and currently includes the following:

- | | |
|--------------------------------|---|
| 1. Filter strips | 7. Bioretention basin |
| 2. Grass channels | 8. Dry detention basins |
| 3. Enhanced swales (dry & wet) | 9. Wet detention ponds |
| 4. Infiltration trenches | 10. Stormwater wetlands |
| 5. Bioslopes | 11. *Open Graded Friction Course (OGFC) |
| 6. Sand filters | |

*Typically, OGFC will be one of the most cost effective BMPs since it is a material substitution for conventional asphalt pavement. The use of OGFC as a BMP will depend on roadway characteristics rather than site constraints and requires approval for use from OMAT. Therefore, it has been listed last in the list of most cost effective BMPs.

3.3.5 Low Impact Development and Green Infrastructure Practices

BMP design information, and other GDOT requirements, can be found in chapter 10 of this manual. In addition, a list of exclusions and infeasibilities to help designers determine if GDOT's MS4 permit requires a post-construction stormwater BMP on a GDOT project is provided in chapter 10.

A growing national trend has been the incorporation of LID and Green Infrastructure (GI) into the design of construction and post-construction stormwater practices. As a requirement of the MS4 permit, LID and GI practices must be considered and will need to be employed where appropriate.

The three key concepts listed in section 3.2 are all LID concepts that attempt to minimize construction impacts.

Figure 3.4 - Typical LID/GI practice: grass channels & rural section in place of concrete curb & gutter [\(3-5\)](#)



Additional information on specific LID/GI practices is detailed in the subsequent BMP sections of chapter 10. A checklist is also provided, as part of the *MS4 Post-Construction Stormwater Report*, to document the use of LID/GI practices. This documentation process is part of the MS4 permit requirements and should be included with each set of construction plans for projects located in a designated MS4 area. See the [GDOT Manuals & Guides website](#) for the *MS4 Post-Construction Stormwater Report*.

3.4 Project Requirements

At the beginning of any GDOT roadway design, understanding project requirements is a fundamental step in the success of the design effort. From a drainage design perspective, knowing the following criteria will make the process much more efficient:

- Applicable GDOT policies
- Required documentation (calculation summaries, checklists, reports, etc.)
- Permitting and applicable agency coordination

3.4.1 GDOT Policy

The majority of GDOT's policy regarding stormwater design is included in this drainage manual. For example, acceptable hydrologic and hydraulic methods are found in chapter 4, *Hydrology & Hydraulics*, and requirements for gutter spread are found in chapter 6, *Pavement Drainage*.

Two milestone reviews are associated with GDOT projects: the first being the Preliminary Field Plan Review (PFPR) and the second being the Final Field Plan Review (FFPR). A concept-level (preliminary) hydrology study for detention and water quality is optional. If completed, the concept-level hydrology study should be sufficient in detail to begin evaluating for outfall level exclusions

and infeasibilities, estimate right-of-way needs and provide a preliminary cost estimate for MS4 permit compliance at each stormwater discharge location. Refer to the Plan Development Process Manual and Flowcharts for more detailed information on what is required at each project milestone.

Concept

It is important to establish the MS4 requirements during the conceptual stage of a project in order to minimize project delays and expenses. At a minimum, the MS4 Concept Report Summary must be submitted with the Concept Report. If the information is available, it is recommended that preliminary drainage areas be delineated and a drainage area map be submitted along with the MS4 Concept Report Summary. The GDOT Stormwater BMP Planning Tool for MS4 Projects may be used to complete an early evaluation of stormwater requirements in each basin. Infeasibility and exclusions are not applied at this time unless the designer is 100% certain they will apply in final design. If there is a possibility that a BMP is feasible for a basin, assume that a BMP will be installed. If a concept-level (preliminary) hydrology study is completed, submit only the following items with the Concept Report:

- MS4 Concept Report Summary
- Drainage Area Map(s)
- GDOT Post-Construction BMP Summary Table (An appropriate summary table format is Attachment B of the MS4 Post-Construction Stormwater Report and can be completed in the GDOT Stormwater BMP Planning Tool for MS4 Projects.).

PFPR

During preliminary design, designers should have a better understanding of site limitations and the project design. All exclusions and infeasibilities can be evaluated to determine if post-construction stormwater BMPs are required for each outfall drainage area. Documentation of the evaluation process and subsequent design of any post-construction stormwater BMPs is included in the [MS4 Post-Construction Stormwater Report](#). Refer to the [MS4 PDP Flowchart](#) for incorporating MS4 requirements into the design process. The GDOT Stormwater BMP Planning Tool for MS4 Projects is a resource that can be used to assist with the MS4 design. The following stormwater planning requirements for PFPR must be documented in the *MS4 Post-Construction Stormwater Report*:

1. A review of the Concept Hydrology Study, if applicable
2. A hydrology and hydraulic analysis including the design of the detention and water quality structures
3. Detailed design of each of the structures including the following:
 - a. Percent impervious
 - b. Drainage area
 - c. Existing and post-construction runoff coefficient(C)
 - d. Curve number (CN) used (if using the NRCS TR-55 Method)
 - e. Average slope of the site
 - f. Site soil conditions

- g. Stage-storage relationships and flow stage relationships of existing and post-construction conditions
 - h. Hydraulic conductivity (K) for infiltration BMPs if applicable. See Chapter 10 for applicability.
 - i. Grading plan of any ponds (proposed contours bold and existing contours faded)
 - j. Checklist detailing location of discharge outlets, BMP used or determination of infeasibility, and basic design values necessary (C existing and C post-construction, for instance).
 - k. Checklist of LID/GI practices implemented
4. Documentation of infeasibility for those discharge locations determined to be infeasible (including a letter addressed to the chief engineer documenting the reason or reasons for the infeasibility)

FFPR

The FFPR is the second milestone submittal for GDOT projects. For FFPR, BMP details, including outlet structure details and dimensions, and BMP specifications must be complete. During the FFPR, the PFPR hydrology and hydraulics are reviewed. During this review, GDOT will determine whether all necessary changes have been made to the hydrology and hydraulics study since the last update. The detailed design information for stormwater structures will also be reviewed for the most recent project updates. For requirements concerning actual construction plans, GDOT has created a Plan Presentation Guide (PPG). ⁽³⁻⁴⁾ As stated in the PPG:

“This document shall establish and define guidelines for plan presentation for all projects under Department oversight to assure that all plans have a consistent appearance, include all pertinent information to construct the project, and reflect high quality workmanship.”⁽³⁻⁴⁾

3.4.2 Project Documentation

The PPG document includes guidelines on the preparation of plans for each individual drawing series, both drafting and the actual project elements that need to be visually shown. Along with other GDOT policy manuals, the PPG can be found online in .pdf format at the following website: http://www.dot.ga.gov/PartnerSmart/DesignManuals/Plan/Plan_Presentation_Guide.pdf.

Project documentation varies based on what aspect of stormwater design is being performed and at what review stage the project resides. A project specific drainage notebook is required for documenting criteria outlined in the PDP. This notebook will include all of the necessary calculations used for stormwater design purposes and, at a minimum, will include the documentation shown in Figure 3.5.

Figure 3.5 - Stormwater project documentation requirements

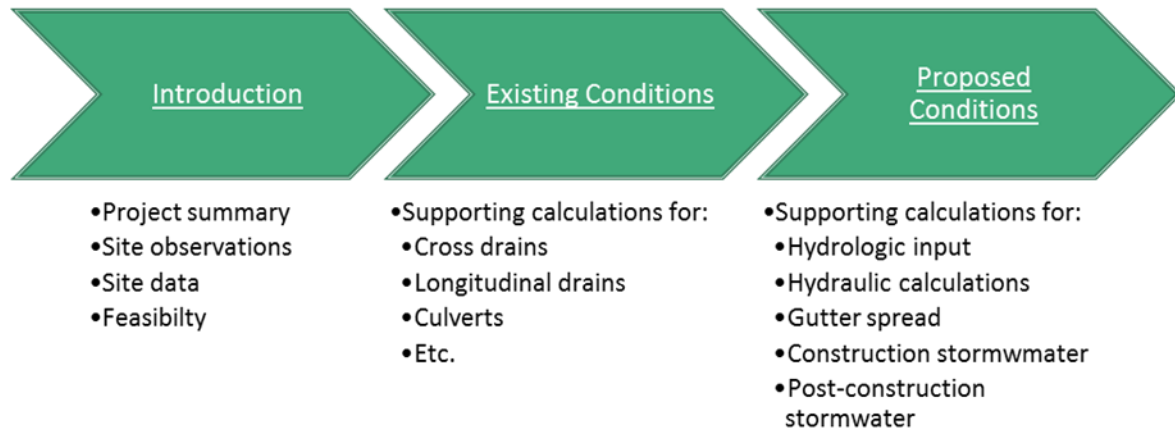

3.4.3 Permitting and Other Agencies

Project documentation also serves as a method for the designer to demonstrate permit compliance to the maximum extent practicable (MEP) according to the stormwater management plans. The MEP concept acknowledges that not all designs and projects are capable of meeting the same standards, but striving to meet those standards should be to the maximum extent practicable. This can be addressed by either documentation of meeting permit requirements or providing a rationale as to why a potential stormwater component was excluded or determined infeasible. This information is provided in the *GDOT Post-Construction Stormwater Report* referenced in chapter 10.

Table 3.1 Agencies & Permits

<i>Agency</i>	<i>Permit</i>
USACE (Wetlands)	NWP, IP, Section 404
FEMA (Floodplains)	CLOMR, LOMR
GADNR-CRD (Coastal Region)	Coastal Marshlands Protection Permit
GA EPD (Impaired Stream)	NPDES, Stream Buffer Variances
FWS (Endangered Species)	Regional Endangered Species Permit
NMFS (National Marine Fisheries Service)	Regional Endangered Species Permit

Any design considerations that may have an effect on the environment should be cross-referenced with the GDOT’s *Environmental Procedures Manual*. (3-2) Detailed information on the National Environmental Policy Act (NEPA) and the Georgia Environmental Policy Act (GEPA) is provided in the EPM if applicable. Access to this manual is available through GDOT’s website <http://www.dot.ga.gov/PartnerSmart/DesignManuals/Environmental/GDOT-EPM.pdf>.

Other rules and requirements that apply may be due to special design considerations, or project location. Location specific considerations may be warranted when a project site is near a historical preservation area, recreation area, or the Etowah River. See Table 3.1 for a list of these location specific considerations and the associated permits.

Maintenance Challenges

In addition to outside agencies, it is important to take into account intra-agency coordination. One GDOT department to consider is the maintenance department. Planning and location studies should take into consideration potential erosion and sedimentation problems upon completion of highway construction. If a particular district location will require frequent and expensive maintenance due to drainage, alternative locations should be considered unless the potentially high-maintenance costs can be reduced by special design features. Experience in the district area is the best indicator of maintenance problems, and interviews with maintenance personnel could be extremely helpful in identifying potential drainage problems. Reference to highway maintenance and flood reports, damage surveys, newspaper reports, and interviews with local residents could be helpful in evaluating potential maintenance problems. [\(3-1\)](#)

During highway construction, channel changes, minor drainage modifications, and revisions in irrigation systems usually carry the assumption of certain maintenance responsibilities by GDOT. Potential damage from the erosion and degradation of stream channels and problems caused by debris can be of considerable significance from a maintenance standpoint. [\(3-1\)](#)

Legal Consideration

A goal in highway drainage design should be to perpetuate natural drainage, insofar as practicable. Courts look with disfavor upon infliction of damage that could reasonably have been avoided, even where some alteration in flow is legally permissible. Basic laws relating to the liability of governmental entities are undergoing radical change, with a trend toward increased governmental liability. Drainage laws are also undergoing change, with the result that older and more specific standards are being replaced by more flexible standards that tend to depend on the circumstances of the particular case. [\(3-1\)](#)

In water law matters, designers should recognize that the state is generally held to a higher standard than a private citizen. In general, designers should not address a question of law without the aid of legal counsel. Whenever drainage problems are known to exist or can be identified, drainage and flood easements or other means of avoiding future litigation should be considered, especially in locations where a problem could be caused or aggravated by the construction of a highway. [\(3-1\)](#)

It is often helpful in the planning and location phase of a project to document the history and present the status of existing conditions or problems and supplement the record with photographs and descriptions of field conditions. Such thoroughness is essential, because the GDOT may be blamed for flooding or erosion damage caused by conditions that existed prior to highway construction. [\(3-1\)](#)

Chapter 3 References

1. American Association of State Highway and Transportation Officials (AASHTO). 2005. Model Drainage Manual, 3rd Ed.
2. Georgia Department of Transportation (GDOT). 2012. [Environmental Procedures Manual](#)
3. Georgia Department of Transportation (GDOT). 2011. [Plan Development Process – 2000 \(PDP\)](#). Policies and Procedure 4050.
4. Georgia Department of Transportation (GDOT). 2012. [Plan Presentation Guide](#), Version 01.50.
5. Georgia Stormwater Management Manual (GSMM - Blue Book), 2001. [Technical Handbook](#). First Edition, Vol. 2.
6. Georgia Soil and Water Conservation Commission (GSWCC – Green Book), 2014. "[Manual for Erosion and Sediment Control in Georgia](#)," Sixth Edition.
7. Thompson, P.L., Kilgore, R.T. 2006, Hydraulic Design of Energy Dissipators for Culverts and Channels, [Hydraulic Engineering Circular No. 14](#), FHWA-NHI-06-086. Federal Highway Administration (FHWA), U.S. Department of Transportation, Washington, D.C.

Intentionally Left Blank

Chapter 4. Hydrology & Hydraulics - Contents

Chapter 4. Hydrology & Hydraulics - Contents	4-i
4.1 Hydrology	4-1
4.1.1 Guidelines	4-1
4.1.1.1 Acceptable Design Methods	4-1
4.1.1.2 Design Discharge Criteria	4-4
4.1.1.3 Design Storm Characteristics.....	4-5
4.1.2 General Design Data	4-5
4.1.3 Peak Flow Determination Procedures	4-6
4.1.3.1 Regional Evaluation	4-6
4.1.3.2 The NRCS TR-55 Method.....	4-6
4.1.3.3 The Rational Method.....	4-7
4.1.4 Hydrograph Types and Development.....	4-12
4.1.5 Other Relevant Hydrologic Information	4-12
4.2 Hydraulics.....	4-12
4.2.1 Introduction.....	4-12
4.2.2 General.....	4-13
4.2.3 General Flow Classification	4-13
4.2.4 Basic Principles	4-13
4.2.4.1 Continuity Equation	4-14
4.2.4.2 Energy Equation.....	4-14
4.2.4.3 Momentum Equation	4-16
4.2.5 Weirs and Orifices	4-16
4.2.5.1 Weirs	4-16
4.2.5.2 Orifices	4-18
4.2.6 Open-Channel Flow	4-19
4.2.6.1 Introduction	4-19
4.2.6.2 Detailed Flow Classification	4-19
4.2.6.3 Manning's Equation.....	4-19
4.2.6.4 Froude Number	4-21
4.2.6.5 Specific Energy Diagram and Evaluation of Critical Depth	4-23
4.2.7 Closed-Conduit Flow	4-25
4.2.7.1 Types of Flow in Closed Conduits.....	4-25
4.2.7.2 Energy Losses	4-26
Chapter 4 References.....	4-27

Chapter 4. Hydrology & Hydraulics

4.1 Hydrology

4.1.1 Guidelines

Drainage design requires knowledge of the hydrologic characteristics of the area. GDOT uses several methods to determine peak runoff flow rates and volumes that have proven to be reliable for use in design, operation, and maintenance of GDOT's highway systems. This chapter provides GDOT's policies and an explanation of these methods. Designers should see the *References* appendix at the end of this manual for other publications that offer a more thorough explanation of the background and theory of these methods.

4.1.1.1 Acceptable Design Methods

The designer should use the hydrological method that is consistent with the characteristics of the basin under consideration. All finalized hydrologic calculations should be signed and sealed by a licensed professional engineer from the state of Georgia. See Table 4.1 and Table 4.2 below for more information on hydrologic methods.

Table 4.1 – Typical Applications of Acceptable Hydrologic Methods

Application	Hydrologic Methods		
	Rational Method	NRCS TR-55 Method	USGS Equations
Water Quality		X	
Channel Protection		X	
Overbank Flood Protection		X	X
Extreme Flood Protection		X	X
Storage Facilities		X	
Outlet Control Structures		X	
Gutter Spread	X		
Storm Drain Pipes	X	X	
Culverts	X	X	X
Bridges		X	X
Small Channels	X	X	X
Natural Channels		X	X
Energy Dissipation	X	X	X

Table 4.2 – Limitations for Hydrologic Methods

Method	Watershed Area Limitation	Notes
Rational	0 - 200 acres	Recommended for basins < 64 acres
NRCS TR-55 Method	Usually < 2,000 acres and has hydrologic homogeneity	None
USGS Urban Regression Equations	See most current USGS publication	1.0 mi ² = 640 acres
USGS Rural Regression Equations	See most current USGS publication	1.0 mi ² = 640 acres

Existing Information: Hydrologic studies resulting in established flow rates for given design storm events have been completed for many locations in Georgia. These studies have many forms and provide valuable information. Some sources of these studies include the following:

- Flood Insurance Studies –FEMA link: (<http://www.fema.gov>)
- Floodplain Information Reports –USACE
- Local community drainage master plans
- Nearby local projects completed by other entities

Published Flow Records: The designer should use published flow records when available. Flow records are typically collected on larger watersheds, and therefore, this approach in defining design peak discharge is more commonly used for bridge and large culvert projects. A minimum record of 10 years should be used to provide a reasonable statistical model. (4-11) This flow data can be gathered from a variety of agencies, such as:

- USGS – USGS data for Georgia can be found at the following website: <http://waterdata.usgs.gov/ga/nwis/nwis>
- FEMA FIS. FEMA Effective FIS data can be found at the following website: <https://msc.fema.gov/webapp/wcs/stores/servlet/CategoryDisplay?catalogId=10001&storeId=10001&categoryId=12002&langId=-1&userType=null&type=7&dfirmCatId=12009&future=false>

Statistical analysis is used for estimating the design peak discharge for the gaged site and for nearby sites on the same stream.

Peak annual stream flows are measured primarily for streams with significantly large drainage areas or for streams that are located in hydrologically sensitive areas. Where peak stream flow is measured, the data can be statistically fit to a frequency distribution to estimate peak flow rates for storm events with specific recurrence intervals. "Guidelines for Determining Flood Flow Frequency" (4-11) establishes the Log-Pearson Type III frequency distribution as the base statistical method to

analyze an annual series of peak flow rates. Manual computation using computer programs such as the Hydrologic Engineering Center’s Statistical Software Package (HEC-SSP), or websites such as http://water.usgs.gov/osw/bulletin17b/dl_flow.pdf can be used to complete these calculations of peak flow rates.

Regional Evaluation: Peak stream flow records have also been used together with known basin characteristics to produce generalized peak flow rate equations applicable to all streams within physiographically similar regions. Five such regions are delineated for Georgia as shown in Figure 4.1. The USGS developed regression equations by performing a regression analysis on drainage basin characteristics to determine which were most highly correlated to peak flow rates. The regional regression equations relate peak flow rate for a specific recurrence interval to a particular basin’s characteristics. Separate equations are used for basins that are primarily rural and for those that are primarily urban. A watershed is considered urban if its impervious area is 10 percent or greater. (4-4) Refer to section 4.1.3.1 for further information regarding regional evaluation using the USGS equations for Georgia.

Figure 4.1 - Georgia flood frequency region map (4-5)

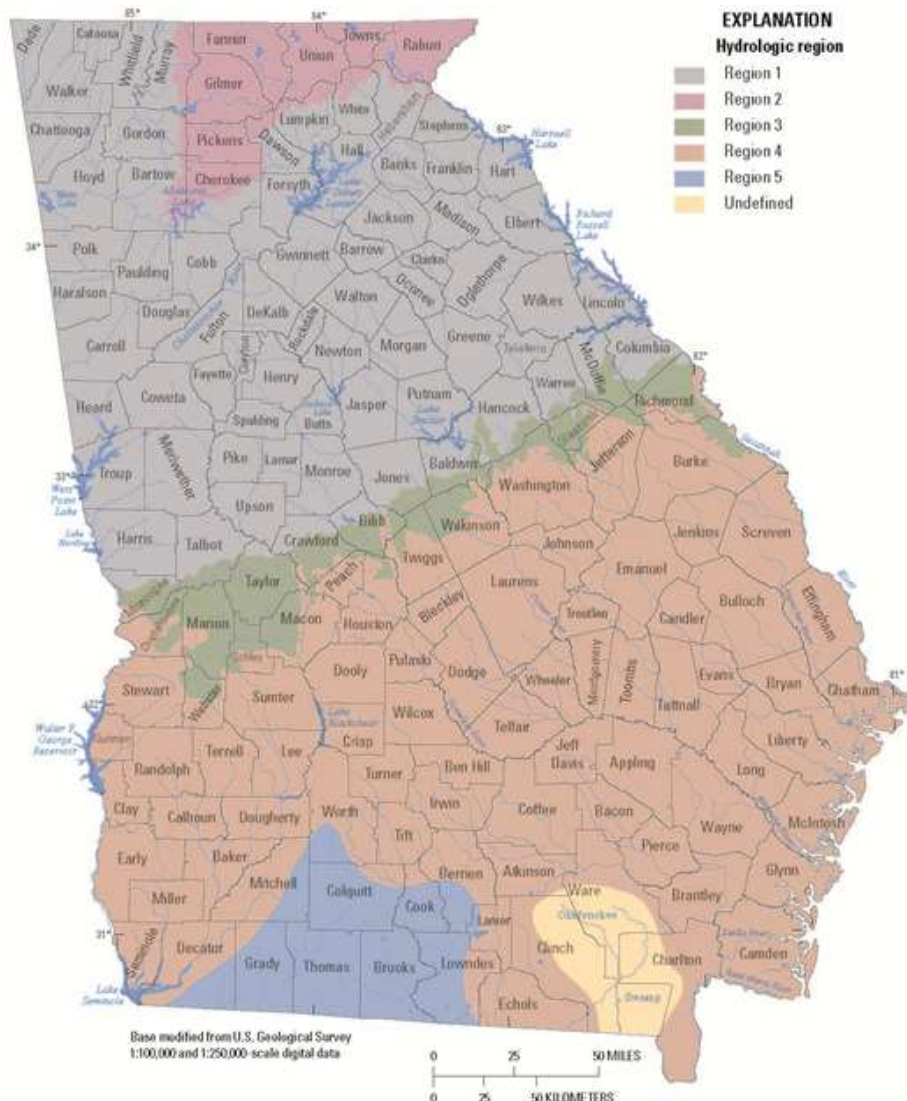

Regional regression equations are used to estimate the peak flow rates. USGS reports [\(4-4, 4-5\)](#) describe these regression equations, which vary in applicability by region and can be used for drainage areas from 0.10 to 9,000 square miles (see section 4.1.3.1 for area limitations by region).

Rational Method: The rational method was developed for estimating the peak flow rates resulting from the 2-year to 10-year rainfall events in small urban drainage basins. This method is recommended for use in basins with drainage areas less than 64 acres, but with careful choice of the runoff coefficient, C, can be used for drainage basins up to 200 acres in size. This method estimates a peak discharge only, but several forms of the modified rational method can be used to estimate the peak discharge and generate a hydrograph for flow routing, the DeKalb modified method being one of the best.

NRCS TR-55 Method: The TR-55 method provides simplified procedures to calculate hydrographs, particularly in urbanizing areas based on NRCS (formerly Soil Conservation Service (SCS)) procedures. This method is fully described in the Soil and Water Conservation Commission's *Manual for Erosion and Sediment Control in Georgia*, appendix A-1 and B-1.⁽⁴⁻³⁾ Adjustment factors as outlined in appendix A-2 of the manual may also be appropriate. TR-55 can be used on basins up to 2,000 acres in size as long as the drainage basin is hydrologically homogeneous. Because larger basins are less likely to be hydrologically homogeneous, basins over 2,000 acres should be carefully examined before using this method. The latest version of TR-55 should be used and is available at: https://www.nrcs.usda.gov/Internet/FSE_DOCUMENTS/stelprdb1044171.pdf.

4.1.1.2 Design Discharge Criteria

Design frequency for GDOT roadway drainage facilities is based on achieving a balance between construction cost, maintenance needs, amount of traffic, potential flood hazard to adjacent property, and expected level of service. The design frequencies presented in Tables 6.3, 7.1, 8.2, and 13.1 are the minimum that will achieve this balance for the various road classifications and types of drainage facilities.

Storm drainage structures should be designed on the basis of the design frequencies in Tables 6.3, 7.1, 8.2, and 13.1 such that they shall not dangerously increase the flood hazard for upstream or downstream properties.

The design frequency for a given storm event is the reciprocal of the probability that a storm event will be equaled or exceeded in a given year. For example, if a storm event has a 10 percent chance of being equaled or exceeded in a year, the storm event will probably be equaled or exceeded on average every 10 years. The designer should note that the 10-year storm event will not be equaled or exceeded once every 10 years, but has a 10 percent chance of being equaled or exceeded in any given year. Therefore, the 10-year storm event could conceivably occur in consecutive years, or possibly even more frequently.

The minimum recommended design frequency storm of 25 years should be used, if possible. The GSWCC requires that erosion control structures be designed for the 25-year storm event. For longitudinal pipes and inlet spacing, see chapter 7 for additional information. For cross drains (culverts), see chapter 8 for additional information.

4.1.1.3 Design Storm Characteristics

Stream-flow measurements for determining a design storm frequency relationship at a site are generally unavailable. Therefore, peak runoff rates and hydrographs can be estimated using statistical or empirical methods. The design discharge should be reviewed for other structures over the stream, historical data, and previous studies including FIS. The design discharge that best reflects local project conditions should be used, with the reasons documented on the hydrologic design form.

Peak-runoff rate for the design condition is adequate for conveyance structures such as storm drains, open channels, or culverts. However, if the design must include storm event routing for detention, retention, post-construction stormwater ponds, or any other attenuating structure or system, then a hydrograph for the storm event will be required.

Conveyance structure design is based on peak flow rate. Methods described in section 4.1.3 include procedures for estimating the peak flow rate.

Volumetric runoff rate is depicted as a hydrograph with discharge in cubic feet per second plotted against time. The area under the curve is the volume of flow. Published flow records include data for the actual hydrograph experienced which can be of value in identifying volume. However, this information would likely require adjustment to provide the specific temporal, spatial, and frequency characteristics that are needed. The TR-55 method provides a simplified tabular method to compute the runoff volume. The USGS regional regression equations and the modified rational method can also be used to produce flood hydrographs.

Certain data are required prior to using many of the hydrologic methods presented in this manual. The following is a description of the typical data required to begin a hydrologic study and how to obtain it.

4.1.2 General Design Data

Size of the Drainage Basin: The drainage area can be determined from field surveys, USGS topographic maps, aerial photographs, or geospatial information.

Slope: The slope of the drainage area can be determined from field surveys, USGS topographic maps, or geospatial information.

Land Use: Land use conditions can be determined by field surveys, aerial photography, or geospatial information.

Soil and Geological Data: The type of soil and its infiltration characteristics within the drainage area will have an important effect on stormwater runoff. Soil and soil moisture characteristics can be obtained by field classification and testing, from NRCS soil surveys at <http://websoilsurvey.nrcs.usda.gov>, or geospatial information. Soil infiltration will vary with the magnitude and intensity of the rainfall.

Rainfall: The amount, pattern, spatial distribution, and duration for various frequency rainfall events for Georgia are published in TP40, (4-6) NOAA Atlas 14, Volume 9 (HYDRO-35), (4-7) and in individual hydrologic method publications such as TR-55. (4-10)

Rainfall Intensity: Rainfall intensity relationships have been developed for most weather stations that record precipitation and have been summarized into intensity-duration-frequency (IDF) curves

applicable to a defined region. Rainfall intensity can be determined using data obtained from NOAA Atlas 14.

The Rational Method Runoff Coefficient: The runoff coefficient C value reflects land use, soil type, and slope. The C value can be thought of as a factor used to compute the effective drainage basin area. It is directly related to the percent imperviousness. The higher the C value, the higher the runoff rate.

The NRCS Curve Number (CN): The NRCS CN value also reflects land use, soil type, and slope. In addition, the CN value also includes the hydrologic soil group and hydrologic condition. Like the Rational C value, a CN value is directly related to percent imperviousness.

4.1.3 Peak Flow Determination Procedures

4.1.3.1 Regional Evaluation

The designer should first check to see if the drainage basin or any portion of it is gaged. Where there are published flow records within the drainage basin, the recorded hydrologic data should be used.

For rural ungaged drainage basins, regression equations are used to determine peak flow rates. The equations are based on watershed and climate characteristics within each of the five hydrologic regions in Georgia. To estimate peak flow rates in rural ungaged areas, use the equations provided in the latest version of the USGS publication *Magnitude and Frequency of Rural Floods in the Southeastern United States*. (4-5) In addition to the regression equations, USGS has also published an Excel spreadsheet titled "Application of Methods Spreadsheet" that calculates peak flow rates for both rural and urban conditions. The spreadsheet for rural conditions is located on the USGS website <http://pubs.usgs.gov/sir/2009/5043/>.

The referenced USGS equations are applicable for rural ungaged sites with drainage basin areas meeting the guidelines of the most recent publication, for any given hydrologic region. These equations may be improved for an ungaged site near a gaged site by using a weighting factor. The gage weighting method is explained in the current USGS publication. (4-5)

Regression equations are also available for determining peak flow rates in urban areas and should be used where appropriate. The equations outlined in the latest version of the USGS publication *Magnitude and Frequency of Floods for Urban and Small Rural Streams in Georgia* (4-4) should be used for urban calculations. The USGS Excel spreadsheet for urban peak flow calculations is at the following website: <http://pubs.usgs.gov/sir/2011/5042/>.

For areas that are urbanizing or not clearly rural or urban in land use, peak flows should be computed by both methods and the higher value used. On a nationwide basis, these regional equations have been compiled under the National Streamflow Statistics (NSS) program. The NSS program includes stand-alone computer software available at: <http://water.usgs.gov/software/NSS/>.

The two sets of regression equations are updated periodically; be sure to use the most current equations.

4.1.3.2 The NRCS TR-55 Method

The TR-55 method is also used to estimate peak discharge. This method is primarily used for the design of post-construction stormwater BMPs, although it is used for other calculations as well. See

section 10.2.2 of this manual for more detailed information on the NRCS TR-55 method as it applies to the design of post-construction stormwater BMPs. One other resource to reference is the *GSWCC Manual for Erosion and Sediment Control in Georgia*, Appendices A-1 and B-1, for a complete description of the method. The manual in its entirety can be located here: http://gaswcc.georgia.gov/sites/gaswcc.georgia.gov/files/related_files/site_page/GSWCC-2016-Manual-As-Approved-by-Overview-Council.pdf.

Additionally, documentation and computer programs for completing calculations using this method can be located at www.wcc.nrcs.usda.gov. If a higher degree of accuracy is warranted, or if the watershed is large and complex, use computer programs such as NRCS Technical Release 20 (TR-20), the USACE Hydrologic Engineering Center Hydraulic Modeling Software (HEC-HMS), or AQUAVEO Watershed Modeling System (WMS).

4.1.3.3 The Rational Method

The rational method is based on the assumption that rainfall occurs at a constant intensity over the entire basin for a storm duration equal to at least the time of concentration of the basin. This produces a peak rate of runoff, which remains constant as long as the rain continues at the same rate. The preferred range of application for the rational method is for areas up to 64 acres in size, but it may be used, with care, for areas up to 200 acres. As the drainage area gets larger, the assumptions related to time of concentration and a uniformly distributed rainfall occurring at a constant rate begin to break down.

The formula for the rational method is depicted below in Equation 4.1:

$$Q = CIA \tag{4.1}$$

Where:

- Q = Peak rate of flow (ft³/s)
- C = Runoff coefficient, the ratio of runoff to total rainfall (dimensionless)
- I = Average rainfall intensity for a duration equal to the time of concentration (in/hr)
- A = Drainage area (acres)

Runoff Coefficient: The runoff coefficient, C, in the rational formula is a ratio expressing the total precipitation that becomes stormwater runoff. Selecting the runoff coefficient for a drainage area requires careful engineering judgment by the designer. The runoff coefficient is a function of the land use, ground slope, topography, rainfall infiltration rate into the soil, and other factors. Table 4.3 gives applicable values for runoff coefficients for a 10-year storm frequency. The runoff coefficient should be adjusted for use with less frequent storms by multiplying the runoff coefficient by a frequency adjustment factor (f_a). Less frequent storms require modification of the runoff coefficient because infiltration and other losses have a proportionally smaller effect on runoff. This adjustment is applicable to areas of exposed soil or vegetation or for C values less than 0.6 and is subject to engineering judgment. Values for f_a are given in Table 4.4.

The runoff coefficient should never be greater than 0.95, except for water-covered surfaces.

Where the drainage area is a composite of several land use types, a weighted runoff coefficient is calculated by using the following equation:

$$C_{weighted} = \frac{C_1 a_1 + C_2 a_2 + \dots + C_n a_n}{A_{total}} \quad (4.2)$$

Time of Concentration: The time of concentration, t_c , is the time required for stormwater runoff to travel from the most hydrologically remote point of the drainage basin to the basin outlet, where remoteness relates to travel time, not necessarily distance. The time of concentration is a function of the size and shape of the drainage basin, slope of the land, land use, rainfall intensity, and how the runoff is conveyed. One method of calculating t_c is the segmental approach, which is the summation of travel times for the individual travel segments. Runoff begins as overland sheet flow, may or may not become shallow-concentrated flow, and becomes concentrated flow down gradient. The sum of the travel times from sheet (overland) flow, shallow concentrated flow, and the concentrated flow segments (gutters, swales, channels, etc.) is the t_c .

$$t_c = t_1 + t_2 + t_3 + t_n \quad (4.3)$$

Even for drainage basins of less than 1 acre, the designer should not use a time of concentration that is less than 5 minutes.

Travel time for sheet flow is commonly calculated using a form of the Kinematic Wave Equation.

$$t_1 = \left(\frac{K_u}{I^{0.4}} \right) \left(\frac{n \times L}{\sqrt{S}} \right)^{0.6} \quad (4.4)$$

Where:

- t_1 = Sheet flow travel time in minutes
- n = Manning's roughness coefficient for sheet flow (Table 4.5)
- L = Length of sheet flow path in feet (Maximum length of 100-ft)
- I = Design storm rainfall intensity (in/hr) for given duration*
- S = Slope of overland flow (ft/ft)
- K_u = Empirical coefficient equal to 0.933

**Table 4.3 – Rational Method Runoff Coefficients
(2-, 5-, and 10-Year Return Frequency)**

Type of Cover	Flat (0%-2%)	Rolling (2%-10%)	Hilly (Over 10%)
Pavement and Roofs	0.95	0.95	0.95
Earth Shoulders	0.50	0.50	0.50
Drives and Walks	0.75	0.80	0.85
Gravel Pavement	0.50	0.55	0.60
City Business Areas	0.80	0.85	0.85
Suburban Residential	0.25	0.35	0.40
Apartment Homes	0.50	0.60	0.70
Single Family Residential	0.30	0.40	0.50
Lawns, Very Sandy Soil	0.05	0.07	0.10
Lawns, Sandy Soil	0.10	0.15	0.20
Lawns, Heavy (clay) Soil	0.17	0.22	0.35
Grass Shoulders	0.25	0.25	0.25
Side Slopes, Earth	0.60	0.60	0.60
Side Slopes, Turf	0.30	0.30	0.30
Median Areas, Turf	0.25	0.30	0.30
Cultivated Land, Clay and Loam	0.50	0.55	0.60
Cultivated Land, Sand and Gravel	0.25	0.30	0.35
Industrial Areas, Light	0.50	0.70	0.80
Industrial Areas, Heavy	0.60	0.80	0.90
Parks and Cemeteries	0.10	0.15	0.25
Playgrounds	0.20	0.25	0.30
Woodlands and Forests	0.10	0.15	0.20
Meadows and Pasture Land	0.25	0.30	0.35
Pasture with Frozen Ground	0.40	0.45	0.50
Unimproved Areas	0.10	0.20	0.30
Water Surfaces	1.00	1.00	1.00

Table 4.4 – Frequency Adjustment Factors

Storm Frequency	f_a
25-year	1.1
50-year	1.2
100-year	1.25

*Design storm per TR-55 methodology is the 2-year, 24-hour storm event, in inches for the specific hydrologic region. Precipitation frequency estimates can be found using NOAA Atlas 14 (<http://hdsc.nws.noaa.gov/hdsc/pfds/>).

Flow regime, changing from sheet flow to shallow concentrated flow, is not always apparent and consequently, it is typical to assume a maximum sheet flow length of 100 feet if shallow concentrated flow is not evident in the field.

Given velocity, the travel time for any travel path segment is computed using Equation 4.5.

$$T_t = \frac{\text{Flow Length}}{\text{Velocity}} \quad (4.5)$$

Shallow-concentrated flow occurs between sheet flow and open-channel flow. TR-55 has equations to calculate velocity, as a function of slope and surface type, which are the following:

$$\text{Unpaved surface:} \quad V = 16.13 S^{0.5} \quad (4.6)$$

$$\text{Paved surface:} \quad V = 20.33 S^{0.5} \quad (4.7)$$

Following shallow-concentrated flow, storm drainage concentrates into natural drainage channels or constructed drainage facilities as open-channel (gravity) flow or closed-conduit (pressure) flow. Concentrated flow includes what is conveyed by swales, channels, streams, or closed conduit drainage facilities. If the flow concentrates in an open channel, the velocity may be estimated from Manning's equation (Equation 4.8).

$$V = \frac{1.49}{n} R^{2/3} S^{1/2} \quad (4.8)$$

Where:

V = Velocity, (ft/s)

n = Manning's roughness coefficient

R = Hydraulic radius (defined as the flow area divided by the wetted perimeter), ft

S = Slope, (ft/ft)

**Table 4.5 – Manning’s Roughness Coefficient,
n, for Sheet Flow**

Surface Description	n
Smooth asphalt	0.011
Smooth concrete	0.012
Ordinary concrete lining	0.013
Good wood	0.014
Brick with cement mortar	0.014
Vitrified clay	0.015
Cast iron	0.015
Corrugated metal pipe	0.024
Cement rubble surface	0.024
Fallow (no residue)	0.05
Cultivated soils	
Residue cover < 20%	0.06
Residue cover > 20%	0.17
Range (natural)	0.13
Grass	
Short grass prairie	0.15
Dense grasses	0.24
Bermuda grass	0.41
Woods*	
Light underbrush	0.40
Dense underbrush	0.80
*When selecting n, consider cover to a height of about 1.2 inches. This is only part of the plant cover that will obstruct sheet flow.	

Note that an iterative computation process is necessary to solve Manning’s equation because the initial flow depth must be estimated. As with shallow concentrated flow, the travel time for each concentrated flow segment is then computed using Equation 4.5.

Rainfall Intensity: In the rational method, rainfall intensity, I , depends on storm duration. The designer can then determine rainfall intensity, I , for the computed duration and desired frequency by using the nearest established IDF relationship for that location.

Rainfall intensities can be determined using data obtained from NOAA Atlas 14.

4.1.4 Hydrograph Types and Development

A partial list of different types of hydrographs includes the following:

1. Natural hydrographs obtained directly from stream gage data.
2. Synthetic hydrographs obtained from watershed parameters and storm characteristics to simulate natural hydrographs.
3. A natural or synthetic unit hydrograph for 1 inch of direct runoff occurring uniformly over the entire watershed from a storm of a specified duration. The direct-runoff volume is determined, and the ordinates of the direct-runoff hydrograph are divided by the observed runoff in inches.
4. Dimensionless unit hydrograph, which eliminates the effect of basin size and much of the effect of basin shape. The hydrograph is made dimensionless by expressing the ordinate (vertical axis) values as the ratio of discharge to peak discharge and the abscissa (horizontal axis) values as the ratio of the time to time-to-peak.

4.1.5 Other Relevant Hydrologic Information

One of the most common methods to develop a hydrograph is based on the NRCS curve number method. Many standard hydrology textbooks and references detail the application of this method. A simplified tabular hydrograph method is provided in TR-55. Other complex watersheds require the use of computer programs such as the NRCS WinTR20 or USACE's HEC-HMS.

For sites affected by regulation from dams or having other significant storage volume upstream of the project site, the storage should be considered when routing the various floods through the basin. Inflow and outflow hydrographs are used to determine the design discharges.

For tidal areas, the storm peak flow rates are determined by tidal computer models, using the downstream boundary conditions (typically stage and time storm surge hydrographs) along with the applicable upland riverine discharge (upland drainage basin).

Helpful tidal sites are: <http://tbone.biol.sc.edu/tide/>

The designer has the option of using TR-55 as a check for areas within the range of 30 to 500 acres. A larger upper range may be used in flat areas. Certain watersheds may lend themselves to the analytical methods presented in TR-55 which may be more appropriate, particularly in the coastal areas and areas with sandy and/or sandy loam soils.

4.2 Hydraulics

4.2.1 Introduction

Basic concepts and general equations for gravity flow (open-channel) and pressure flow (closed-conduit) will be briefly discussed in this section. Further discussions on gravity and pressure flow follow in chapters 5 and 7. Since these concepts are elementary in nature and their derivations are not shown here, refer to applied hydraulic textbooks or to FHWA publications for additional information. All finalized hydraulic calculations should be signed and sealed by a licensed professional engineer from the state of Georgia.

4.2.2 General

The design of drainage structures requires the use of the continuity, energy, momentum, and other equations. These equations were derived on the basis of fundamental equations by a combination of mathematics, laboratory experiments, and field studies.

4.2.3 General Flow Classification

Flow can be classified as either gravity (non-pressure) or closed-conduit (pressure) flow. Gravity flow can then be further defined as: (1) uniform or nonuniform flow; (2) steady or unsteady flow; and (3) subcritical (tranquil) or supercritical (rapid) flow. Likewise, closed-conduit flow can be further defined as either steady or unsteady flow; and either laminar or turbulent flow.

Whether fluid flow is laminar or turbulent depends on surface roughness of the conveyance and a dimensionless number called the Reynolds number, Re , which is the ratio of inertial forces to viscous forces. This number is defined mathematically as:

$$Re = \frac{\rho \times D \times V}{\mu} \quad (4.10)$$

Where:

- V = velocity, ft/s
- D = diameter of conveyance, ft
- ρ = fluid density, lbf/ft³
- μ = fluid viscosity, lbf s/ft²

Depending on surface roughness, laminar flow generally occurs when the Reynolds number is less than 2,100. Turbulent flow generally occurs when the Reynolds number is above 4,000, except for extreme smooth materials. A transitional zone exists between 2,100 and 4,000.

4.2.4 Basic Principles

The basic equations of flow are continuity, energy, and momentum. They are derived from the laws of (1) the conservation of mass; (2) the conservation of energy; and (3) the conservation of linear momentum. Conservation of mass is another way of stating that (except for mass-energy interchange) matter can neither be created nor destroyed. The principle of conservation of energy is based on the first law of thermodynamics which states that energy must at all times be conserved. The principle of conservation of linear momentum is based on Newton's second law of motion which states that a mass (of fluid) accelerates in the direction of and in proportion to the applied forces on the mass.

Analysis of flow problems are much simplified if there is no acceleration of the flow or if the acceleration is primarily assumed to be in one direction, which is considered one-dimensional flow. Equations given in the manual are written specifically as they apply to the analysis of one-dimensional flow and not two-dimensional or more complex fluid flow.

4.2.4.1 Continuity Equation

The continuity equation is based on conservation of mass. For steady flow of incompressible fluids it is:

$$V_1 A_1 = V_2 A_2 = Q = VA \text{ or alternatively } Q_{in} = Q_{out} \quad (4.11)$$

Where:

$V =$ Average velocity in the cross section perpendicular to the area, ft/s

$A =$ Area perpendicular to the velocity, ft²

$Q =$ Volume flow rate or discharge, ft³/s

This form of the continuity equation is applicable when the fluid density is constant, the flow is steady, there is no significant lateral inflow or seepage (or they are accounted for), and the velocity is perpendicular to the area (Figure 4.2).

For unsteady flow, conservation of mass requires that the net rate of fluid mass flow into any elemental control volume be equal to the time rate of change of fluid mass storage within the element, and the continuity equation takes the following form:

$$Q_{in} - Q_{out} = dS/dt \quad (4.12)$$

Where:

$Q_{in} =$ Volumetric fluid flow into the control volume, ft³/s

$Q_{out} =$ Volumetric fluid flow out of the control volume, ft³/s

$dS =$ Volumetric change in fluid mass storage, ft³

$dt =$ Change in time across control volume, s

Figure 4.2 - Sketch of continuity concept through a control volume element

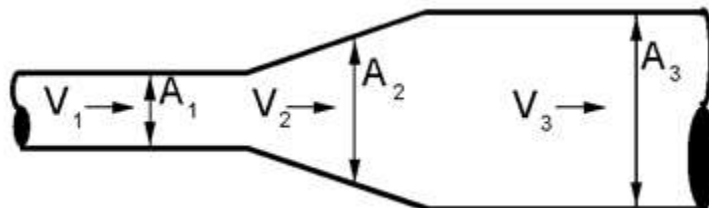

4.2.4.2 Energy Equation

The energy equation, in terms of the three components of total head, is derived from the first law of thermodynamics, which states that energy is a conserved physical quantity. The three head components in Equation 4.13 are the velocity head (h_v), the pressure head (h_p), and the elevation head (h_z). The head loss (h_L) equals the amount of energy lost and converted into thermal energy. Equation 4.13 represents a fluid state for steady incompressible flow and is shown as:

$$\frac{V_1^2}{2g} + \frac{p_1}{\gamma} + Z_1 = \frac{V_2^2}{2g} + \frac{p_2}{\gamma} + Z_2 + h_L; h_{v1} + h_{p1} + h_{z1} = h_{v2} + h_{p2} + h_{z2} + h_L \quad (4.13)$$

Where:

- V = Average velocity in the cross section, ft/s
- g = Acceleration of gravity, 32.2 ft/s²
- p = Pressure, lbs/ft²
- γ = Specific weight of water, 62.4 lbs/ft³ at 60°F
- Z = Elevation above a horizontal datum, ft
- h_L = Head loss due to friction and form losses, ft

The energy grade line (EGL) is a representation of the total specific energy, shown as the elevation that equals the sum of the h_v, h_p, and h_z, the total head. The hydraulic grade line (HGL) is below the EGL by the amount of the velocity head, or is the sum of just the pressure and elevation heads. The application of the energy equation in gravity and pressure flow is illustrated in Figures 4.3 and 4.4.

Figure 4.3 - Gravity flow (open-channel)

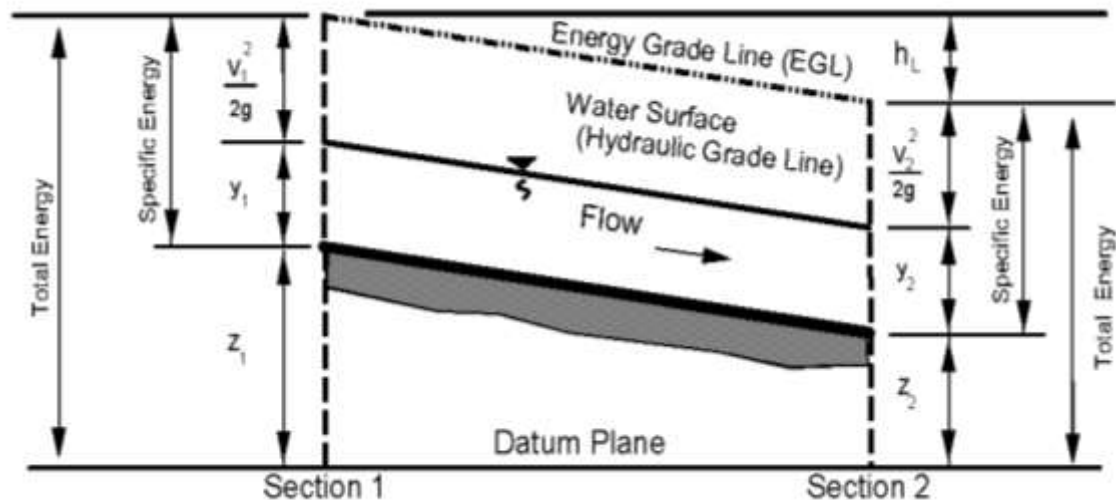
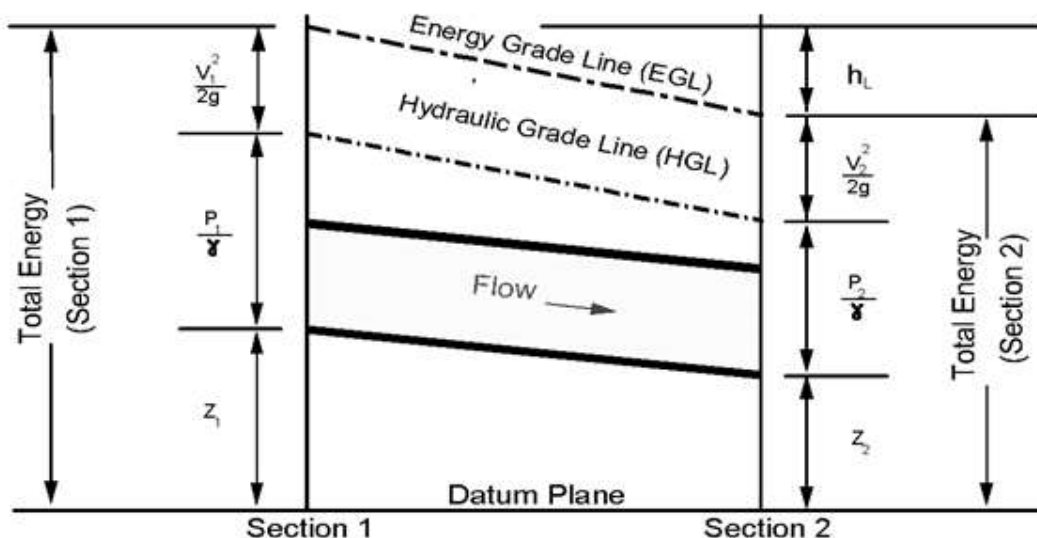

Figure 4.4 - Pressure flow (closed-conduit flow)



Since highway stormwater pipe joints are not designed to be watertight under pressure, the HGL should not exceed the pipe crown if practicable. When the HGL rises above the crown of the pipe at an upstream structure, the storm system becomes hydraulically surcharged. Similarly, if an open-channel flow condition in a storm drain is supercritical, care must be taken to ensure that a hydraulic jump does not occur which might also create a hydraulically surcharged scenario with the HGL above the roadway elevation.

4.2.4.3 Momentum Equation

The momentum equation is derived from Newton's second law which states that the summation of all external forces on a system is equal to the change in momentum (the impulse). In the x-direction for steady flow with constant density it is

$$\sum F_x = \rho Q(V_{x2} - V_{x1}) \tag{4.14}$$

Where:

- $F_x =$ Forces in the x direction, lbs
- $\rho =$ Density, 1.94 slugs/ft³
- $Q =$ Volume flow rate or discharge, ft³/s
- $V =$ Velocity in the x direction, ft/s

The momentum equation is used to estimate forces on pipe bends and to analyze hydraulic jumps.

4.2.5 Weirs and Orifices

4.2.5.1 Weirs

A weir is typically a notch of regular shape (rectangular, square, or triangular), with a free surface. The edge or surface over which the water flows is called the crest. A weir with a crest where the

water springs free of the crest at the upstream side is called a sharp-crested weir. If the water flowing over the weir does not spring free and the crest length is short, the weir is called a not sharp-crested weir, round-edge weir, or suppressed weir. If the weir has a horizontal or sloping crest sufficiently long in the direction of flow that the flow pressure distribution is hydrostatic it is called a broad-crested weir (Figure 4.5). As with orifices, weirs can be used to measure water flow. Strictly speaking, a sharp-crested weir used for measurement purposes, must be aerated on the downstream side and the pressure on the nappe downstream must be atmospheric. Examples of weir flow that are of interest to the highway engineer are flow into grates, flow spilling through curb inlets, flow into culverts, outlet structures for detention basins, and flow-over approach embankment.

Figure 4.5 - Weir types

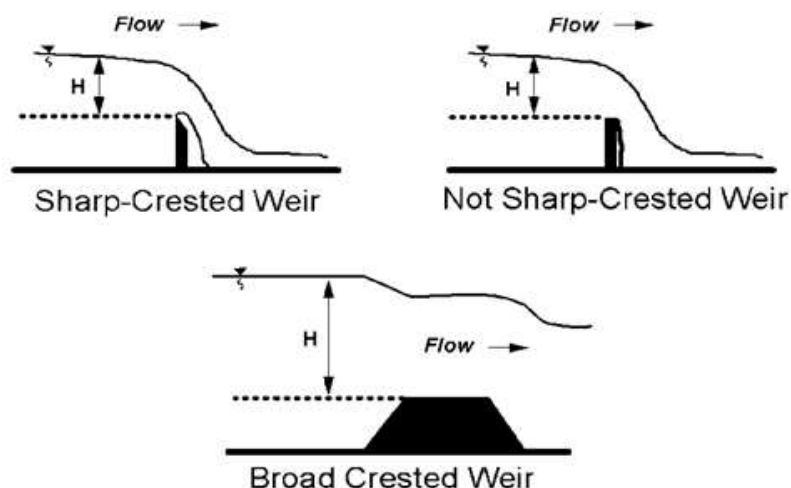

The discharge across a weir (sharp-crested or broad-crested) is calculated using Equation 4.15 below:

$$Q = C_D \times L \times H^{3/2} \quad (4.15)$$

Where:

- $Q =$ Discharge, ft^3/s
- $C_D =$ Coefficient of discharge for weirs, sharp-edge or broad-crested
- $L =$ Weir length (equal to the width of the bottom of the crest), ft
- $H =$ Head on the weir, ft (depth of flow above the weir crest measured upstream at the normal depth)

Roadway overtopping is modeled as broad-crested flow because the weir length will be greater than one-half of the head. The equation of flow is the same as Equation 4.15, but the coefficient of

discharge is a function of weir length and head height. The coefficient normally ranges from 2.63 to 3.33.

Coefficients of discharge are given in most handbooks (e.g., HEC-22) for the different types of weirs and flow conditions. Note that correction factors are also available if the weir is submerged. (4-9) As long as the tailwater is less than critical depth, submergence is not a factor.

4.2.5.2 Orifices

An orifice is an opening with a regular shape (e.g., circular or rectangular) through which water flows in contact with the total perimeter. If the opening is flowing only partially full, the orifice operates as a weir. An orifice with a sharp upstream edge is called a sharp-edged orifice. If the jet of water from the orifice discharges into the air, it is called a free discharge. If it discharges under water, it is called a submerged orifice. Orifices are common fluid discharge measuring devices (Figure 4.6), but orifice type flow occurs under other circumstances where head loss, backwater, etc. needs to be determined. Examples of orifice flows of interest to highway engineers are flow through bridges when they are overtopped, flow through culvert inlets, curb inlets flowing full, etc. When a bridge is overtopped the flow through the bridge is orifice flow, but the flow over the bridge is weir flow.

Figure 4.6 – Orifice

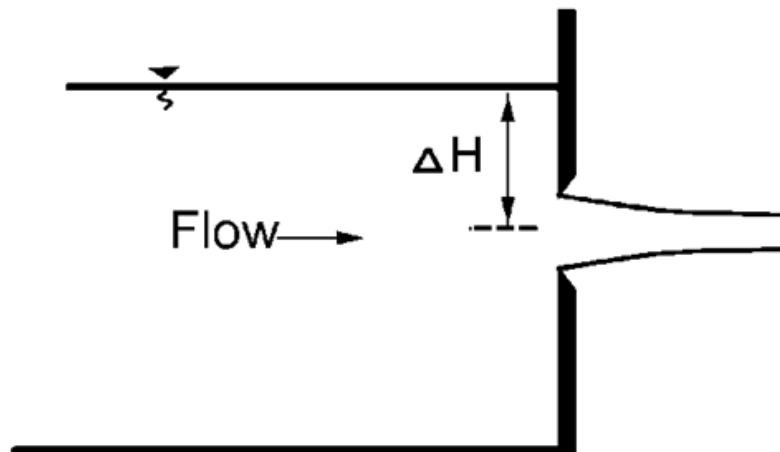

The discharge through an orifice is calculated using Equation 4.16 below:

$$Q = C_D A \sqrt{2g \Delta H} \quad (4.16)$$

Where:

- Q = Discharge, ft³/s
- C_D = Coefficient of discharge, 0.62 for a sharp-edged orifice
- A = Area of the orifice, ft²
- g = Acceleration of gravity = 32.2 ft/s²
- ΔH = Difference in head across the orifice, ft

Coefficients of discharge are given in most handbooks. ⁽⁴⁻¹⁾ For an unsubmerged orifice, the difference in head across the orifice is measured from the centerline of the orifice to the upstream water surface. For a submerged orifice, the difference in head is measured from the upstream water surface to the downstream water surface.

4.2.6 Open-Channel Flow

4.2.6.1 Introduction

Open-channel flow, or gravity flow, occurs when the water surface is at atmospheric pressure, which creates a free surface. It occurs in open channels such as curb and gutters, roadside channels, streams, and rivers. Open-channel flow also occurs in closed conduits that are not flowing full such as storm drains and culverts. All of the basic equations apply to open-channel flow: continuity, energy, and momentum equations. Open-channel flow, however, is more complex than closed-conduit flow since the cross-sectional flow area is not constant. The water surface may vary from steady uniform flow conditions to rapidly varied flow situations, from one-dimensional flow to two- and three-dimensional flow, and from steady to unsteady flow. Each of these flow variations adds complexity to the analysis of open-channel flow.

4.2.6.2 Detailed Flow Classification

The classification of gravity flow is summarized as follows:

Steady flow occurs when the flow velocity and depth at any given location does not vary with time.

1. Uniform flow occurs when flow velocity and depth do not change along a channel with a constant slope and cross section. This flow type rarely occurs in natural channels.
2. Varied flow occurs when the flow velocity and depth changes along a channel due to a change in channel slope, cross section, or roughness. Varied flow consists of two types:
 - a. Gradually varied flow – changes occur slowly in flow for longer channel distances.
 - b. Rapidly varied flow – changes occur faster due to short channel distances and transitions.

The steady, uniform flow case and the steady, non-uniform flow case are the most fundamental types of flow treated in highway engineering hydraulics. For the design of most highway drainage structures, steady flow is often assumed and will be the basis of the discussion in the section. However, the engineer must confirm that this assumption is reasonable. For structures in tidally influenced areas, this basic assumption may not be valid and a more appropriate analysis may be required. For these situations, contact the GDOT Hydraulic Group.

4.2.6.3 Manning's Equation

Uniform flow exists when the gravitational energy resulting from the longitudinal channel slope is balanced with the losses due to friction between the wetted perimeter and the boundary of the channel. Therefore, the slope of the water surface, channel bed, and the energy grade line are parallel. Numerous equations have been developed to analyze this flow condition. The one most commonly used by highway engineers was developed by Robert Manning, an Irish engineer. Equation 4.17 follows:

$$V = \frac{1.49}{n} R^{2/3} S^{1/2} \quad (4.17)$$

Where:

- V = Mean velocity, ft/s
 n = Manning's coefficient of roughness, dimensionless
 R = Hydraulic radius, ft
 S = Slope, ft/ft

The hydraulic radius, R, is a measure of hydraulic efficiency that depends on the shape of the channel and depth of flow. Of all cross-sectional shapes, the circular shape is the most hydraulically efficient. Moreover, the maximum rate of discharge under gravity flow in a circular pipe with a fairly constant n-value occurs when the flow depth is 94% of the pipe's diameter. The hydraulic radius is given by equation 4.18.

$$R = A / P \quad (4.18)$$

Where:

- A = Area perpendicular to flow, ft²
 P = Wetted perimeter, ft

When the Manning's equation is combined with the continuity equation, Equation 4.19 is then used to compute discharge:

$$Q = \frac{1.49}{n} A R^{2/3} S^{1/2} \quad (4.19)$$

Note that Manning's equation is valid also for pressure flow; but other equations, such as the Darcy-Weisbach equation, are preferred.

For gravity flow, Manning's equation is strictly applicable only to uniform flow. Even though uniform flow is rarely attained in highway stormwater infrastructure, uniform flow is assumed and Manning's equation is usually used for steady gradually varied flow where the change in velocity from section to section is very small. The error by assuming uniform flow is small in comparison to the error in determining the design discharge.

Individual structures may be constructed of several materials with varying Manning's n-values. Embedded culverts are a common example when the sides of the culvert are constructed of concrete and the bottom is embedded in natural streambed material. In this case, a weighted Manning's n-value should be calculated.

Several programs, including Hydrologic Engineering Center's River Analysis System (HEC-RAS), HY-8, and FlowMaster will calculate a weighted average n-value directly. In the absence of computer aid, the designer will need to calculate the average n-value by hand.

Several methods are available for calculating the average n. The methods all have one thing in common: they are all some form of a finite series that involves the summing of terms. Hand

calculation of the average n-value varies from being extremely tedious to being relatively simple depending on the method used.

As shown in HDS-5, Horton's method, Equation 4.20, uses the length of wetted perimeter as the weight.

$$n = \left(\frac{\sum_{i=1}^n (p_i n_i^{1.5})}{p} \right)^{0.67} \quad (4.20)$$

Where:

- n = Weighted Manning's n-value
- p_i = Wetted perimeter of material i, ft
- n_i = Manning's n value for material i
- p = Total wetted perimeter, ft

In the case of an embedded culvert, the formula can be reduced to the following.

$$n = \left(\frac{(p_b n_b^{1.5}) + (p_s n_s^{1.5})}{p} \right)^{0.67} \quad (4.21)$$

- p_b = Wetted perimeter of the bottom of the culvert (units of length)
- n_b = Manning's n-value for the bottom of the culvert
- p_s = Total wetted perimeter of the sides and the top (if applicable) of the culvert (units of length)
- n_s = Manning's n-value for the bottom of the culvert
- P = Total wetted perimeter (units of length)

4.2.6.4 Froude Number

The Froude Number is a very important parameter in open-channel flow. It is an index of flow regime: subcritical, critical, or supercritical and is defined as the ratio of the inertia forces to the gravitational forces, normally expressed as shown in Equation 4.22 below.

$$Fr = \frac{V}{\sqrt{gy}} \quad (4.22)$$

Where:

- Fr = Froude Number, dimensionless
- V = Velocity of flow, ft/s

$g =$ Acceleration of gravity, ft/s²

$y =$ Hydraulic depth of flow, ft

If the channel is rectangular, the hydraulic depth is simply the depth “d.” For trapezoidal and circular channels, $y = A/T$, the flow area divided by the top width. In general, the hydraulic depth is the flow area divided by the top width of flow.

V and y can be the mean velocity and depth in a channel or the velocity and depth in the vertical. If the former are used, then the Froude Number is for the average flow conditions in the channel. If the latter are used, then it is the Froude Number for that vertical at a specific location in the cross section. The Froude Number uniquely describes the flow pattern in open-channel flow. (4-8)

Note that the denominator of the Froude Number is the same as the celerity of a shallow water wave of small amplitude (the velocity of the wave relative to the velocity of the flow, shown in Figure 4.7).

$$c = \sqrt{gy_0}$$

(4.23)

Figure 4.7 - Definition sketch for small amplitude waves

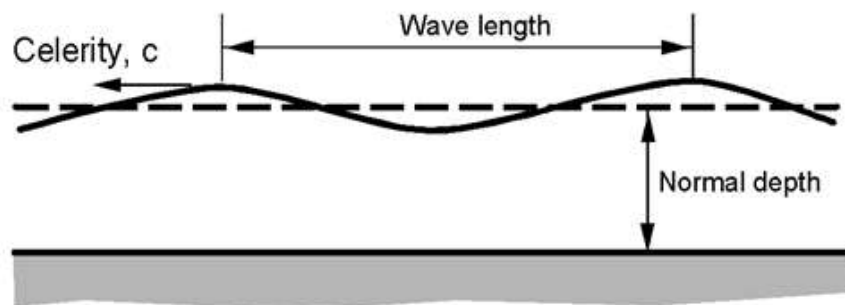

When the velocity of the flow is less than the celerity of the wave, a small amplitude wave resulting from a disturbance will move upstream, and the Froude number will be less than one ($Fr < 1$). This type of flow regime is subcritical or tranquil flow. In other words, the effects of a downstream flow disturbance will propagate upstream.

When the velocity in the flow is greater than the celerity of the wave, the effect of a flow disruption will not be carried upstream, and the Froude number will be greater than one ($Fr > 1$). This type of flow regime is supercritical or rapid flow.

The fact that waves (or surges) cannot move upstream when the Froude Number is greater than 1.0 means the stage discharge relation at a cross section cannot be affected by downstream conditions.

If the velocity of flow is the same as the celerity of the wave, the wave will be stationary, and the Froude number will be one ($Fr = 1$). This flow regime is called critical flow, and the depth of this flow is the critical depth. Flow going from supercritical to subcritical must pass through the critical depth in what is called a hydraulic jump. In a hydraulic drop the flow goes from subcritical to supercritical and again passes through the critical depth.

4.2.6.5 Specific Energy Diagram and Evaluation of Critical Depth

If the elevation head is removed from the energy equation, the sum of the two remaining terms is called the specific energy, or specific head, H , defined as

$$H = \frac{V^2}{2g} + y = \frac{q^2}{2gy^2} + y \quad (4.24)$$

Where:

- H = Specific energy, ft
- q = Unit discharge, defined as the discharge per unit width (ft³/s /ft) in a rectangular channel
- V = Velocity, ft/s
- g = Acceleration of gravity, 32.2 ft/s²
- y = Depth of flow, ft

The specific energy, H , is the height of the total energy above the channel bed. The relationship between the three terms in the specific energy equation, q , y , and H , are evaluated by holding the discharge constant and by examining the relationship between H and y in the specific energy diagram. For any given discharge, there are two flow depths that have the same specific energy: a deep, low velocity flow called subcritical and a shallow, high velocity flow called supercritical. These diagrams for a given discharge or energy are then used in the design or analysis of transitions or flow through bridges. They are explained in the next two sections.

For a given q , Equation 4.24 can be solved for various values of H and y . When y is plotted as a function of H , Figure 4.8 is obtained. There are two possible depths called alternate depths for any H larger than a specific minimum. Thus, for specific energy larger than the minimum, the flow may have a large depth with small velocity or small depth with large velocity. Flow for a given unit discharge q cannot occur with specific energy less than the minimum. The single depth of flow at the minimum specific energy is called the critical depth, y_c , and the corresponding velocity, the critical velocity, $V_c = q/y_c$. The relation for y_c and V_c for a given q (for a rectangular channel) is shown as Equation 4.25.

$$y_c = \left(\frac{q^2}{g} \right)^{1/3} = \frac{V_c^2}{g} \quad (4.25)$$

Note that for critical flow, Equations 4.26 and 4.27 are:

$$\frac{V_c}{\sqrt{gy_c}} = 1 = Fr \quad (4.26)$$

and

$$H_{\min} = \frac{V_c^2}{2g} + y_c = \frac{3}{2}y_c \tag{4.27}$$

Thus, flow at minimum specific energy has a Froude Number equal to 1. Flows with velocities larger than critical ($Fr > 1$) are called rapid or supercritical and flow with velocities smaller than critical ($Fr < 1$) are called tranquil or subcritical.

Figure 4.8 - Specific energy diagram

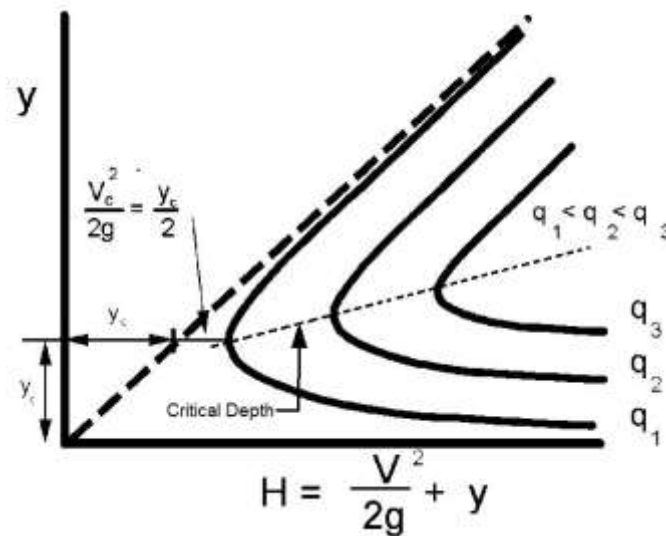

Distinguishing between the types of flow and how the water surface reacts with changes in cross section is important in channel design; thus, the location of critical depth and the determination of critical slope for a cross section of given shape, size, and roughness becomes necessary. Equations for direct solution of the critical depth are available for several prismatic shapes; however, some of these equations were not derived for use in the metric system.

For any channel section, regular or irregular, critical depth may be found by a trial-and-error solution of the following equation:

$$\frac{A_c^3}{T_c} = \frac{Q^2}{g} \tag{4.28}$$

where: A_c and T_c are the area and top width at critical flow. An expression for the critical velocity (V_c) of any cross section at critical flow conditions is:

$$V_c = \sqrt{g y_c} \tag{4.29}$$

$$\text{where: } y_c = A_c / T_c \quad (4.30)$$

Uniform flow within about 10% of the critical depth is unstable and should be avoided in design. As the flow approaches the critical depth from either limb of the curve, a very small change in energy is required for the depth to abruptly change to the alternate depth on the opposite limb of the specific head curve. If the unstable flow region cannot be avoided in design, the least favorable type of flow should be assumed for the design.

4.2.7 Closed-Conduit Flow

4.2.7.1 Types of Flow in Closed Conduits

Flow conditions in a closed conduit can occur as open-channel flow, full gravity flow, or pressure flow. The analysis of open-channel flow in a closed conduit is no different than any other type of open-channel flow and all the concepts and principles previously discussed are applicable. Full gravity flow occurs when the conduit is flowing full, but not under any pressure greater than atmospheric. Pressure flow occurs when the conduit is flowing full and under a pressure greater than atmospheric.

Due to the additional wetted perimeter and increased friction that occurs in a full gravity pipe, a partially full pipe will actually carry greater flow. The average velocity for a closed conduit flowing one-half full is the same as full gravity flow (Figure 4.9). Full gravity flow condition is usually assumed for purposes of storm drain design.

The Manning's equation combined with the continuity equation for a circular section flowing full can be rewritten as the following:

$$Q = \frac{0.46}{n} D^{\frac{8}{3}} S^{\frac{1}{2}} \quad (4.31)$$

Where:

- Q = Discharge, ft³/s
- n = Manning's coefficient, dimensionless
- D = Pipe diameter, ft
- S = Slope, ft/ft

This equation allows for a direct computation of the required pipe diameter. Note that the computed diameter must be increased in size to a larger nominal dimension in order to carry the design discharge without creating pressure flow.

Figure 4.9 - Partially full flow relationships for circular pipes

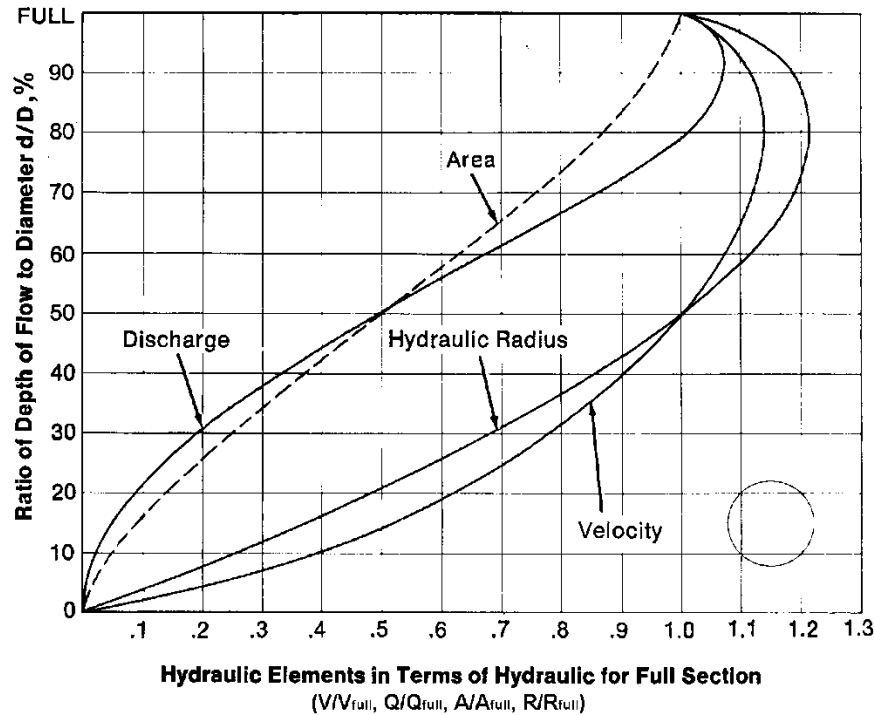

4.2.7.2 Energy Losses

When using the energy equation, all energy losses should be identified. Energy losses can be classified as friction losses or form losses. Friction losses are due to forces between the fluid and boundary material, whereas form losses are the result of various hydraulic structures along the closed conduit. These structures, such as access holes, bends, contractions, enlargements, and transitions, will each cause velocity head losses and potentially major changes in the energy grade line and hydraulic grade line across the structure. The form losses are often called "minor losses," which is misleading since these losses can be large relative to friction losses.

Chapter 4 References

1. Brown, S.A., Schall, J.D., Morris, J.L., Doherty, C.L., Stein, S.M., Warner, J.C. 2009, Urban Drainage Design Manual, [Hydraulic Engineering Circular No. 22](#), FHWA-NHI-10-009. Federal Highway Administration (FHWA), U.S. Department of Transportation, Washington, D.C.
2. Georgia Stormwater Management Manual (GSMM - Blue Book), 2016. [Technical Handbook](#). 2016 Edition.
3. Georgia Soil and Water Conservation Commission (GSWCC – Green Book), 2016. "[Manual for Erosion and Sediment Control in Georgia](#)," 2016 Edition.
4. Gotvald, Anthony J., Knaak, Andrew E. 2008. "[Magnitude and Frequency of Floods for Urban and Small Rural Streams in Georgia, 2008](#)" U.S. Geological Survey Scientific Investigations Report 2011-5042.
5. Gotvald, Anthony J., Feaster, Toby D., Weaver, Curtis J. 2006. "[Magnitude and Frequency of Rural Floods in the Southeastern United States, 2006](#): Volume 1, Georgia," U.S. Geological Survey Scientific Investigations Report 2009-5043.
6. Hershfield, D.M., 1961. "Rainfall frequency atlas of the United States for durations from 30 minutes to 24 hours and return periods from 1 to 100 years," U.S. Weather Bureau [Tech. Paper No.](#) 40, U.S. Dept. Commerce, Washington, D.C.
7. National Oceanic and Atmospheric Administration (NOAA), 2013. "[NOAA Atlas 14, Vol. 9](#)" Precipitation-Frequency Atlas of the United States"
8. Schall, James D., Richardson, Everett V., Morris, Johnny L. 2008, Introduction to Highway [Hydraulics, Hydraulic Designs No. 4](#), FHWA-NHI-08-090. Federal Highway Administration (FHWA), U.S. Department of Transportation, Washington, D.C
9. Schall, James D., Thompson, Philip L., Zerges, Steve M., Kilgore, Roger T., Morris, Johnny L. 2012, Hydraulic Design of Highway Culverts Third Edition, [Hydraulic Design Series No. 5](#), FHWA-HIF-12-026. Federal Highway Administration (FHWA), U.S. Department of Transportation, Washington, D.C.
10. United States Department of Agriculture (USDA). Natural Resources Conservation Service (NRCS). 1986. [TR55 Urban Hydrology for Small Watersheds](#)
11. United States Water Resources Council, 1981. "[Guidelines for Determining Flood Flow Frequency](#)," Bulletin No. 17B of the Hydrology Committee.

Intentionally Left Blank

Chapter 5. Channels - Contents

Chapter 5.	Channels - Contents	5-i
5.1	Introduction.....	5-1
5.2	Design Policy.....	5-2
5.3	Open-Channel Hydraulics	5-2
5.3.1	Types of Flow.....	5-3
5.3.2	Manning's Equation for Mean Velocity and Discharge	5-3
5.3.3	Use of Design Charts to Find Depth of Flow, Velocity, Critical Slope, and Adequacy of Channel Lining	5-4
5.3.4	Stream Channel Analysis and Design.....	5-4
5.3.4.1	Stream Morphology.....	5-5
5.3.4.2	Cross Sections	5-5
5.3.4.3	Manning's n Value Selection	5-5
5.3.4.4	Calibration.....	5-6
5.3.4.5	Slope-Area Method	5-7
5.3.4.6	One-Dimensional Gradually-Varied Flow Profile Analysis	5-7
5.3.4.7	Special Analysis Techniques	5-10
5.3.4.7.1	Two-Dimensional Analysis.....	5-10
5.3.4.7.2	Unsteady Flow Analysis.....	5-11
5.3.4.8	Switchback Phenomenon.....	5-12
5.4	Roadside and Median Channel Guidelines and Criteria.....	5-13
5.4.1	Design Storms.....	5-13
5.4.2	Channel Shape and Protection	5-13
5.4.3	Channel Alignment	5-13
5.4.4	Channel Grade	5-14
5.4.5	Stream-Bank Protection from Erosion.....	5-14
5.4.6	Typical Design Data Required.....	5-14
5.5	Roadside and Median Channel Design Procedures.....	5-15
5.6	Safety	5-16
Chapter 5 References.....		5-18

Chapter 5. Channels

5.1 Introduction

An open channel is a natural or constructed conveyance for water in which the water surface is exposed to the atmosphere (free-surface flow) and gravity alone is the driving force.

Open channels associated with transportation facilities can be described by two main categories: natural stream channels and constructed channels, such as ditches or conveyances.

A natural stream channel is described as:

- A natural channel with its size and shape determined by means of natural forces
- A compound cross section with a main channel for conveying low flow and a floodplain to transport flood flow
- Geomorphologically shaped due to the long-term history of sediment load and water discharge which it experiences

A constructed channel can be a roadside channel, interceptor ditch, or drainage ditch, which can have a regular geometric cross section, and is unlined or lined with constructed or natural material to protect against erosion. Culverts or storm drains are also constructed conveyances where the principles of open-channel hydraulics are applicable during free-surface flow.

The purpose of this chapter is to:

- Establish GDOT policy
- Specify design criteria
- Outline channel design procedures

This chapter is to be used as a tool that will aid the designer when approached with roadside or median channel design. In addition to roadside and median channel design topics, section 5.3 provides guidance on stream channel analysis and design. Some of the stream channel topics introduced include stream morphology, cross sections, Manning's n values, calibration, one-dimensional gradually varied flow profile analysis, and a few special analysis techniques. However, for more information regarding stream studies, assessments of existing stream channels, or guidance on relocating a stream, the designer should refer to chapter 11. In general, this chapter begins with a brief discussion on policy which is followed by an extensive discussion on open-channel hydraulics topics, and concludes with roadside and median channel guidelines and criteria and design procedures.

The designer should consult other chapters of this manual, as appropriate, for additional information regarding open channels, including the following:

- Chapter 4 – Hydrology & Hydraulics
- Chapter 10 – Post-Construction Stormwater Design Guidelines
- Chapter 11 – Stream & Wetland Restoration Concepts
- Chapter 12 – Bridge Hydraulic Design Criteria.

5.2 Design Policy

Open channel design policy is to provide a channel configuration that will convey the naturally occurring flow and/or design stormwater runoff through or adjacent to the transportation facility or through a BMP and back to its original course. See section 5.4 for additional details on roadside and median channels. In general, the following policies apply to all channel designs:

- Channel designs and/or designs of highway facilities that impact channels shall satisfy the policies of the FHWA applicable to floodplain management if federal funding is involved.
- FEMA floodway regulations and USACE permit conditions/regulations for wetland restrictions and stream impacts shall be satisfied.
- Coordination with other federal, state, and local agencies concerned with water resources planning shall have high priority in the planning of highway facilities.
- Safety of the general public shall be an important consideration in the selection of cross-sectional geometry of constructed drainage channels.
- The design of constructed drainage channels or other facilities shall consider the frequency and type of maintenance expected and make allowance for access of maintenance equipment.
- A stable channel is the goal for all channels that are located on highway right-of-way or that impact highway facilities.
- Environmental impacts of channel modifications, including disturbance of fish habitat, wetlands, and channel stability shall be assessed. Channels should not be placed within the limits of delineated wetlands.
- For design storm event requirements, see section 5.4.1.

5.3 Open-Channel Hydraulics

Channel analysis is necessary for the design of a transportation drainage system to assess the following:

- Potential flooding caused by changes in water-surface profile
- Disturbance of the river system upstream or downstream of the highway right-of-way
- Changes in lateral flow distribution
- Changes in velocity or direction of flow
- Need for conveyance and disposal of excess runoff
- Need for channel lining to prevent erosion

This section will specifically discuss guidelines and design criteria applying to open-channel hydraulics for roadside and median channels and stream modifications. For more information, the designer should consult chapter 4 of this manual which provides a general discussion of hydraulics with links to valuable references.

5.3.1 Types of Flow

Open-channel flow is generally classified using the following characteristics:

- Steady or unsteady
- Uniform or non-uniform (varied)
- Subcritical or supercritical

Of these, non-uniform, unsteady, subcritical flow is the most common type of flow in open channels. Due to the complexity and difficulty involved in the analysis of non-uniform, unsteady flow, most hydraulic computations are made with certain simplifying assumptions that allow the application of steady-uniform or gradually-varied flow principles and one-dimensional methods of analysis.

The use of steady flow methods implicitly assumes that the discharge at a point does not change with time, and the use of uniform flow methods assumes that there is no change in velocity, magnitude, or direction with distance along a streamline. Steady-uniform flow is thus characterized by constant velocity and flow rate from section to section along the channel.

Steady-uniform flow is an idealized concept of open-channel flow that seldom occurs in natural channels and is difficult to obtain even in model channels. However, for most practical highway channel applications, the assumption of steady and uniform flow is often adequate for design purposes since changes in width, depth, or direction (resulting in non-uniform flow) is sufficiently small. The changes in channel characteristics occur over a long distance such that flow is gradually varied. For these reasons, use of uniform flow theory is usually within acceptable degrees of accuracy.

The designer must consider non-uniform and/or unsteady flow conditions in some instances, such as, gradually-varied flow in spillways and receiving channels, rapidly-varied flow in energy dissipaters (hydraulic jumps), and around bridge piers. Refer to section 5.3.4.7 for more information on complex hydraulic modeling principles.

5.3.2 Manning's Equation for Mean Velocity and Discharge

Water flows in a sloping drainage channel because of the force of gravity. The flow is resisted by the friction between the water and wetted surface of the channel. As discussed in chapter 4, the Manning's Equation is used to compute the mean velocity in an open channel with steady-uniform flow as shown in Equation 5.1:

$$V = \frac{1.49}{n} R^{2/3} S^{1/2} \quad (5.1)$$

- V = Mean velocity, ft/s
- n = Manning's coefficient of channel roughness
- R = Hydraulic radius (R = A/P)
- S = Slope, ft/ft

When the Manning's equation is combined with the continuity equation, Equation 5.2 is then used to compute discharge, Q:

$$Q = \frac{1.49}{n} AR^{2/3} S^{1/2} \quad (5.2)$$

Typical values of the Manning's n roughness coefficient for various channel types are given in [Appendix D](#). For information on typical cross sections and equations for a particular open channel geometric configuration, see the "Elements of Channel Sections" figure in the USDA National Engineering Handbook, Section 5. [\(5-9\)](#)

5.3.3 Use of Design Charts to Find Depth of Flow, Velocity, Critical Slope, and Adequacy of Channel Lining

In addition to direct application of the Manning's equation to solve for variables of simple trapezoidal channels, another alternative is to use the charts from FHWA document *HDS-3 Design Charts for Open-Channel Flow*. [\(5-4\)](#) For complex channel shapes, use the HEC-RAS computer program or other open-channel hydraulics programs.

The design charts provide a direct solution to the Manning's equation for channels of a given shape and roughness, but auxiliary scales make the charts applicable to other roughness coefficients, n. The abscissa scale is discharge (Q), in cubic feet per second, and the ordinate scale is velocity (V), in feet per second. The charts contain a series of lines that refer to normal depth and channel slope. Given any two of the conditions of flow, the other two elements of flow can be found. A heavy dashed line shows the position of the Critical Curve. Since critical depth is independent of slope and roughness and is only dependent on discharge and cross section shape, no correction is made for n when establishing it. (For channels having the same value of n, for which the chart was constructed, the values above the critical curve indicate supercritical flow and steep slopes and the values below the line indicate sub-critical flow and mild slopes.)

The design charts can also be used for values of n other than that for which the chart was constructed by using the auxiliary scales for Q_n and V_n . To obtain the value of Q_n , the design discharge, Q, is multiplied by the design value of n. At the intersection of Q_n and the slope line, the value of V_n can be obtained. The design velocity, V, is then found by dividing the V_n value by n. The value of the critical depth is read at the intersection of the Q line (not Q_n) and the critical curve and the critical velocity is the V value for this point.

5.3.4 Stream Channel Analysis and Design

Stream channels are usually natural channels with their size and shapes determined by natural forces. Stream channels are also usually compound in cross section with a main channel for conveying low flows and a floodplain to transport flood flows. Rehabilitation of disturbed or relocated natural channels shall incorporate cross section geometry that will effectively convey the design frequency, minimize erosive forces, and provide sufficient floodway as required. See chapter 11 for additional information regarding natural channel design requirements and analyses.

The analysis of a natural stream channel in most cases is in conjunction with the design of a highway hydraulic structure such as a culvert or bridge, or as required by EPD. In general, the objective is to convey the water along or under the highway bridge in such a manner that it will not

cause damage to the highway, stream, or adjacent property. An assessment of the existing channel is usually necessary to determine the potential for problems that might result from a proposed action. The detail of studies necessary should be commensurate with the risk associated with the action and with the environmental sensitivity of the stream and adjoining floodplain. The designer should refer to chapter 11 for more information regarding stream studies, assessments of existing stream channels, or guidance on relocating a stream.

The following sub-sections cover the general guidance for stream channel analysis and design. See section 5.4 for design information on engineered channels.

5.3.4.1 Stream Morphology

A study of the plan and profile of a stream is very useful in understanding stream morphology, or the form or shape of a stream. Plan view appearances of streams are varied and result from many interacting variables. Small changes in a variable can change the plan view and profile of a stream, adversely affecting a highway crossing or encroachment. Conversely, a highway crossing or encroachment can inadvertently change a variable, adversely affecting the stream. Additional information can be obtained through FHWA publications, such as, *HEC-20 Stream Stability at Highway Structures*, and *HDS-6 River Engineering for Highway Encroachments*.

5.3.4.2 Cross Sections

In order to define how the natural flow of a stream is conveyed, hydraulic modeling is conducted with specific data requirements. One hydraulic data requirement includes cross sections. Cross sections provide the designer with factors such as channel depth, channel width, water surface elevation, bank failure, etc.

Cross-sectional geometry of streams is defined by coordinates of lateral distance and ground elevation that locate individual ground points. The cross section is taken normal to the flow direction along a single, straight line where possible but, in wide floodplains or bends, it may be necessary to use a section along intersecting straight lines, i.e., a "dog-leg" section. It is especially important to make a plot of the cross section to reveal any inconsistencies or errors.

Cross sections should be located to be representative of the subreaches between them. Stream locations with major breaks in bed profile, abrupt changes in roughness or shape, control sections such as free overfalls, bends and contractions, or other abrupt changes in channel slope or conveyance will require cross sections taken at shorter intervals to better model the change in conveyance.

Cross sections should be subdivided with vertical boundaries where there are abrupt lateral changes in geometry and/or roughness as for overbank flows. The conveyances of each subsection are computed separately to determine the flow distribution and are then added to determine the total flow conveyance. The subsection divisions must be chosen carefully so that the distribution of flow or conveyance is nearly uniform in each subsection. Selection of cross sections and the vertical subdivision of a cross section are shown in Figure 5.1.

5.3.4.3 Manning's n Value Selection

Manning's n values have been calculated for various types of channels based on stream flow and are provided in the FHWA publication, FHWA-TS-84-204, *Guide for Selecting Manning's Roughness Coefficients for Natural Channels and Flood Plains*. [\(5-2\)](#) This publication is a useful tool

that aids the designer in the determination of Manning’s n values. Pictures are also provided in the manual which offer visual representations of natural channels and floodplains for the user.

Manning’s n values for constructed channels are more easily defined than for natural stream channels. [Appendix D](#) lists typical n values of both constructed channels and natural stream channels.

5.3.4.4 Calibration

The equations should be calibrated with historical high-water marks and/or gaged streamflow data to facilitate accurate representation of local channel conditions. The USGS National Water Information System website offers a source for streamflow characteristics, which can be found here: <http://waterdata.usgs.gov/usa/nwis/rt>. The following parameters, in order of preference, should be used for calibrations: Manning’s n, slope, discharge, and cross section. Proper calibration is essential if accurate results are to be obtained.

Figure 5.1 - Hypothetical cross section showing reaches, segments, and subsections used in assigning n values [\(5-2\)](#)

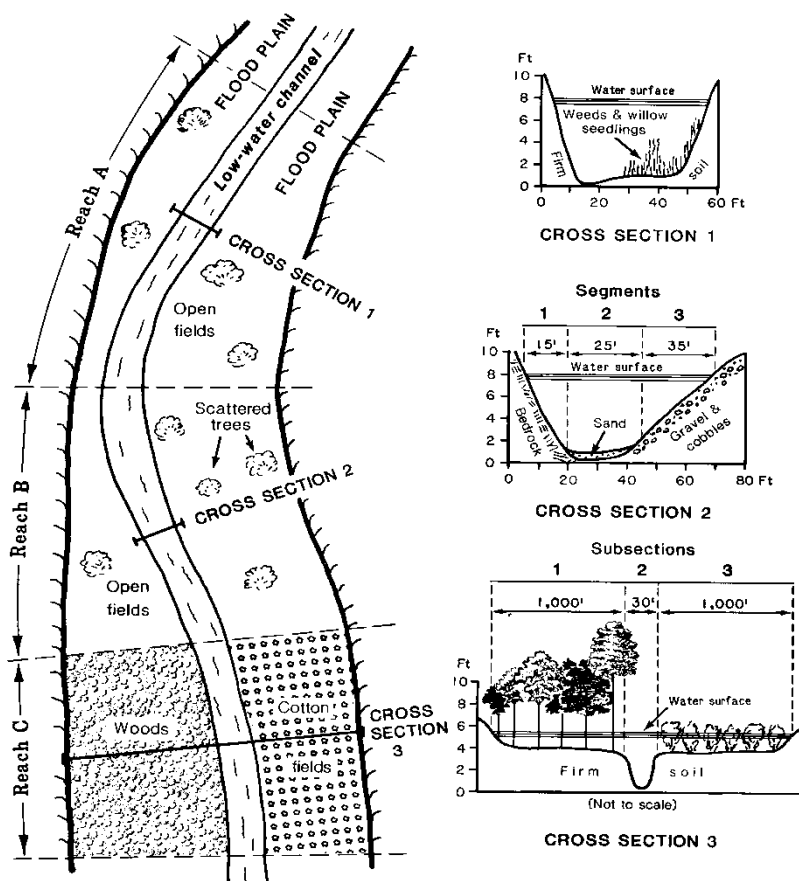

5.3.4.5 Slope-Area Method

A common method used for channel design is the slope-area method (also known as single-section method or slope conveyance method). It is simply a solution of Manning's equation for the normal depth of flow given the discharge and cross section properties including geometry, slope, and roughness (Manning's n value). This method implicitly assumes the existence of steady-uniform flow; however, uniform flow rarely exists in either constructed or natural stream channels. Nevertheless, the slope-area method is often used to design constructed channels for uniform flow as a first approximation and to develop a stage-discharge rating curve in a stream channel for tailwater determination at a culvert or storm drain outlet.

A stage-discharge curve is a graphical relationship of streamflow depth or elevation to discharge at a specific point on a stream. This relationship should cover a range of discharges up to at least the base (100-year) flood.

The stage-discharge curve can be determined as follows:

1. Select the typical cross section at or near the location where the stage-discharge curve is needed.
2. Subdivide cross section and assign n -values to subsections as previously described.
3. Estimate water-surface slope. Because uniform flow is assumed, the average slope of the streambed can usually be used.
4. Apply a range of incremental water surface elevations to the cross section.
5. Calculate the discharge using Manning's equation for each incremental elevation. Total discharge at each elevation is the sum of the discharges from each subsection at that elevation. In determining hydraulic radius, the wetted perimeter should be measured only along the solid boundary of the cross section and not along the vertical water interface between subsections.
6. After the discharge has been calculated at several incremental elevations, a plot of stage versus discharge should be made. This plot is the stage-discharge curve, and it can be used to determine the water surface elevation corresponding to the design discharge or other discharge of interest.

5.3.4.6 One-Dimensional Gradually-Variied Flow Profile Analysis

Another common method used for channel design is the standard step backwater method. This method employs the energy equation to determine the water surface profile along a roadside channel or stream channel during gradually-varied flow. In gradually-varied flow, a type of steady non-uniform flow, changes in depth and velocity take place slowly over large distances, resistance to flow dominates, and acceleration forces are neglected. There are many different flow profile types for gradually-varied flow; the FHWA publication, *Introduction to Highway Hydraulics (HDS-4)* (5-5) provides the background on flow profile types and the standard step method. The manual calculation process for the standard step backwater method is cumbersome and tedious for channels of any length or with numerous variations in cross section shape, roughness, slope, or discharge within the area of interest. Thus, HEC-RAS or another acceptable computer program should be used to calculate water surface profiles when this method is required. (5-6)

The standard step backwater method should be used where the following occurs:

- The channel cross section, slope, roughness, or flow is highly irregular
- A structure (culvert, bridge, weir, gate, etc.) affects the water surface profile
- Stream or channel confluences affect the water surface profile
- The slope area method is either not applicable or not sufficiently accurate
- FEMA level stream analysis and floodplain modeling are required

A detailed description of the standard step backwater method for channels with irregular cross sections, such as streams, may be found in the *HEC-RAS Hydraulic Reference Manual*. [\(5-8\)](#)

Water surface profile computation for the standard step method requires a beginning value of elevation or depth (boundary condition) and proceeds upstream for subcritical flow and downstream for supercritical flow. In the case of supercritical flow, critical depth is often the boundary condition at the control section but, in subcritical flow, uniform flow and normal depth may be the boundary condition. The starting depth in this case can either be found by the slope area method or by computing the water surface profile upstream to the desired location for several starting depths and the same discharge. These profiles should converge toward the desired normal depth at the control section to establish one point on the stage-discharge relation. If the several profiles do not converge, then the analysis may need to be extended downstream, a shorter cross section interval should be used, or the range of starting water surface elevations should be adjusted. In any case, a plot of the convergence profiles can be a very useful tool in such an analysis (see Figure 5.2).

Given a long enough stream reach, the water surface profile computed by the standard step method will converge to normal depth at some point upstream for subcritical flow. Establishment of the upstream and downstream boundaries of the stream reach is required to define the limits of data collection and subsequent analysis. Calculations must begin sufficiently far downstream to assure accurate results at the structure site, and continued a sufficient distance upstream to accurately determine the impact of the structure on upstream water surface profiles (see Figure 5.3).

The USACE publication, *Accuracy of Computed Water Surface Profiles* [\(5-7\)](#) provides equations for determining upstream and downstream reach lengths as follows:

$$L_{dn} = 8,000 (HD^{0.8}/S)$$

$$L_u = 10,000 [(HD^{0.6})(HL^{0.5})]/S$$

Where the following occurs:

L_{dn} = Downstream study length (along main channel), ft (for normal depth starting conditions)

L_u = Estimated upstream study length (along main channel), ft (required for convergence of the modified profile to within 0.1 feet of the base profile)

HD = Average hydraulic depth (1% chance event flow area divided by the top width), ft

S = Average reach slope, ft/mi

$H_L =$ Head loss ranging between 0.5 feet and 5 feet at the channel crossing structure for the 1% chance flood, ft

The USACE publication referenced above (5-7) and the USGS publication for navigable waterways, *Computation of Water Surface Profiles in Open Channels* (5-3) are valuable sources that provide additional guidance on the practical application of the standard step method to highway drainage problems involving open channels. These references contain more specific guidance on cross section determination, location and spacing, and stream reach determination. The USACE document (5-7) also investigates the accuracy and reliability of water surface profiles related to n value determination.

Figure 5.2 - Profile convergence pattern backwater computation

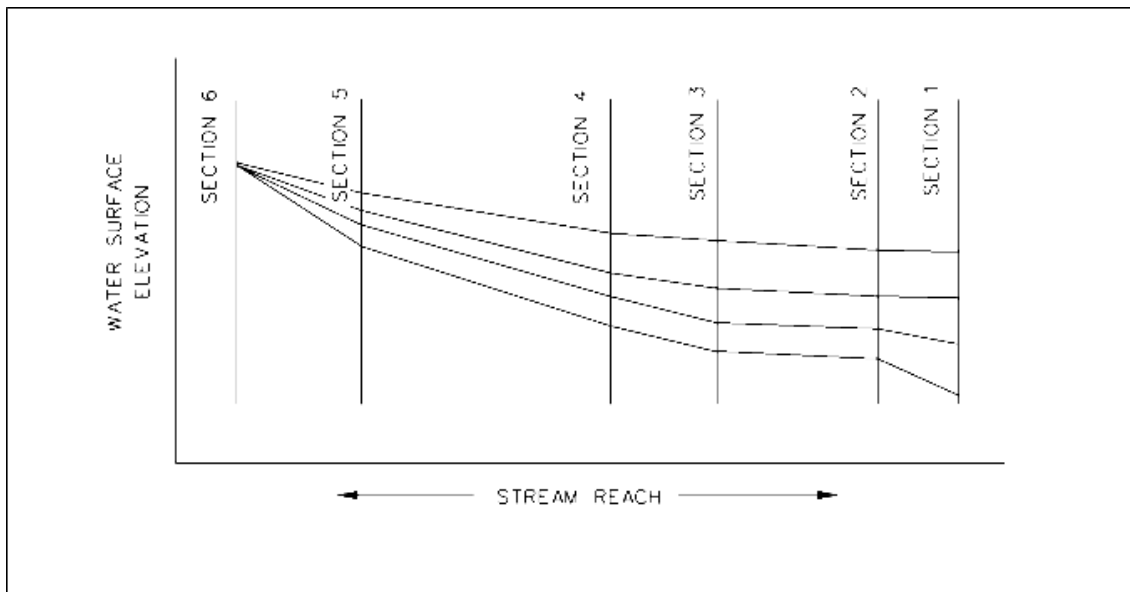
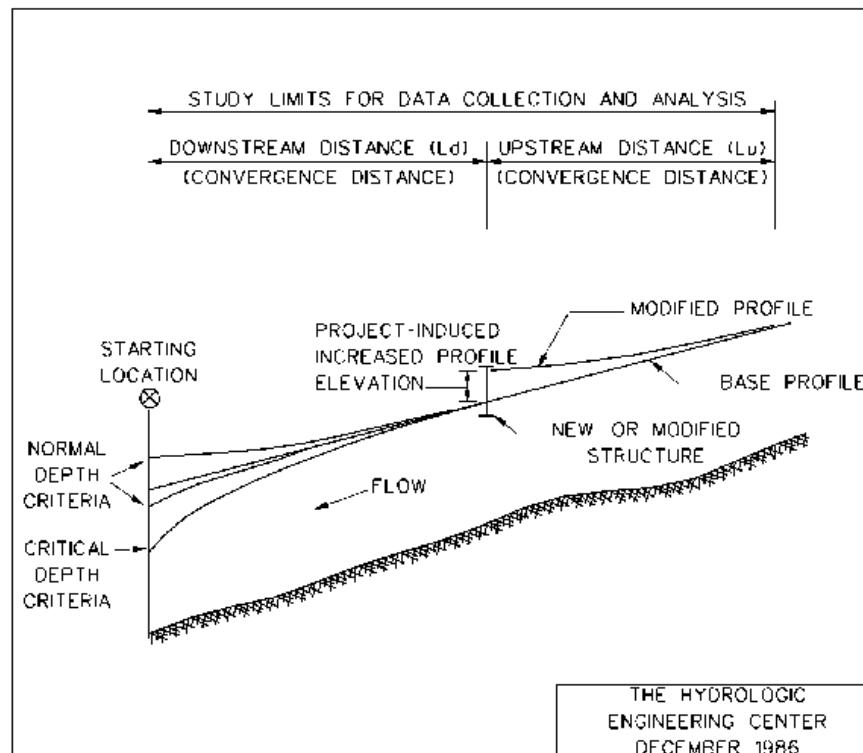

Figure 5.3 - Profile study limits



5.3.4.7 Special Analysis Techniques

Open-channel flow problems sometimes arise that require a more detailed analysis than a slope area method or the computation of a water surface profile using the standard step method. More detailed analysis techniques include two-dimensional analysis, water and sediment routing, and unsteady flow analysis. Computer programs are available for the analysis techniques discussed in this section.

5.3.4.7.1 Two-Dimensional Analysis

Two-dimensional (2-D) models simulate flow in two directions, longitudinal and transverse, at a series of user-defined node points. Flow in the vertical direction is assumed to be negligible. These models can account for transverse flow due to lateral velocities and water surface gradients that cannot be accounted for with one-dimensional models. Examples of such conditions include skewed bridges, floodplain crossings with multiple openings, channel bifurcation, flow around channel bends, and flow around islands.

A 2-D model should be considered for major projects with complex flow patterns that one-dimensional models cannot adequately analyze. Examples of situations where 2-D models should be considered are as follows:

- Wide floodplains with multiple openings, particularly on skewed embankments
- Floodplains with significant variations in roughness or complex geometry such as ineffective flow areas, flow around islands, or multiple channels

- Sites where more accurate flow patterns and velocities are needed to design better and cost-effective countermeasures such as riprap along embankments and/or abutments
- Tidally-affected river crossings and crossings of tidal inlets, bays, and estuaries
- High-risk or sensitive locations where losses and liability costs are high

Following are three commonly used computer programs for 2-D modeling:

FESWMS: *Finite Element Surface Water Modeling System version 3.22*

The FESWMS package consists of two software packages that can model flows in open channels. The first package, FST2DH, is a 2-D finite element surface water computer program that computes the direction of flow and water surface elevation in a horizontal plane. FST2DH has the ability to model hydraulic structures commonly used by hydraulic engineers. The second package, FST1DH is a one-dimensional finite element surface water model that models unsteady flow and sediment transport in open channels. FESWMS is usually recommended for highway crossings of rivers and floodplains because it supports both super and subcritical flow analysis and can analyze roadway overtopping, culverts, and bridges.

See <http://water.usgs.gov/software/FESWMS-2DH/> for information regarding FESWMS.

RMA2: *Surface Water Modeling version 4.56*

RMA2 is a 2-D depth averaged finite element hydrodynamic numerical model. It computes water surface elevations and horizontal velocity components for subcritical, free-surface 2-D flow fields. Using RMA2, both steady and unsteady (dynamic) problems can be analyzed.

SMS: *Surface Water Modeling version 11.1.4*

Surface-water modeling System (SMS) is a comprehensive environment for one- and two-dimensional models dealing with surface water applications. The hydrodynamic models cover a range of applications including river flow analysis, rural and urban flooding, estuary and inlet modeling, and modeling of large coastal domains. FESWMS and RMA2 are modules included in SMS. See <http://www.aquaveo.com/sms> for information regarding SMS.

5.3.4.7.2 Unsteady Flow Analysis

One-dimensional, unsteady flow can be analyzed with the HEC-RAS computer program. Some of the features of HEC-RAS are the network simulation of split flow and combined flow. The effect of storage areas can also be analyzed. This feature is useful when the effects of a stream channel and/or overbank floodwater storage areas are sufficient to allow a significant reduction in peak rates approaching a drainage structure or series of structures. This program can provide more realistic estimates of headwater produced at a series of closely spaced highway drainage structures. HEC-RAS allows the user to analyze lateral overflow into storage areas over a gated spillway, weir, levee, through a culvert, or a pumped diversion. The user can apply several external and internal boundary conditions, including flow and stage hydrographs, gated and controlled spillways, bridges, culverts, and levee systems. HEC-RAS can be an effective tool to analyze tidally-affected river crossings and crossings of tidal inlets, bays, and estuaries.

Two-dimensional, unsteady flow can be analyzed with either FESWMS or RMA2.

5.3.4.8 Switchback Phenomenon

If the cross section is improperly subdivided, the mathematics of the Manning’s equation causes a switchback. A switchback results where the calculated discharge decreases with an associated increase in elevation (Figure 5.4). This occurs when, with a minor increase in water depth, there is a large increase of wetted perimeter. Simultaneously, there is a corresponding small increase in cross-sectional area that causes a net decrease in the hydraulic radius from the value it had for a lesser water depth. With the combination of the lower hydraulic radius and the slightly larger cross-sectional area, a discharge is computed that is lower than the discharge based upon the lower water depth. More subdivisions within such cross sections should be used to avoid the switchback (Figure 5.5).

Figure 5.4 - Switchback phenomenon

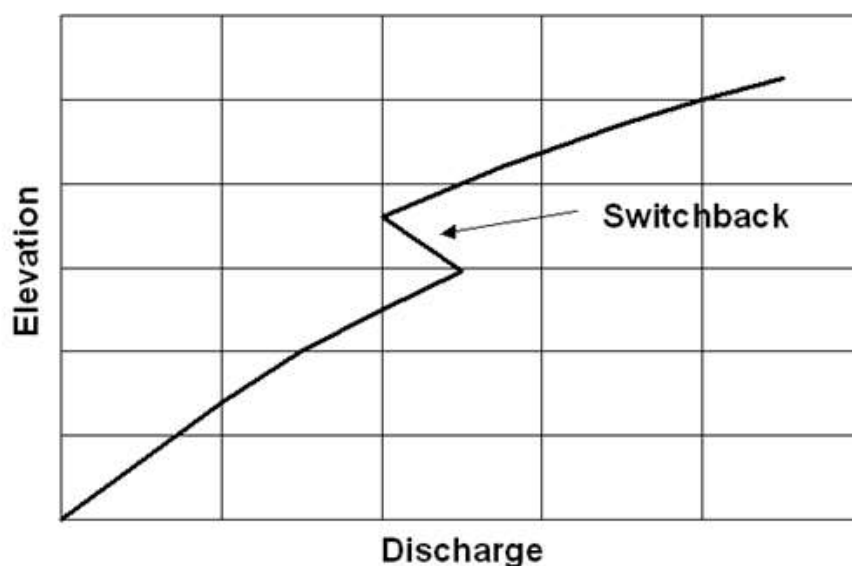
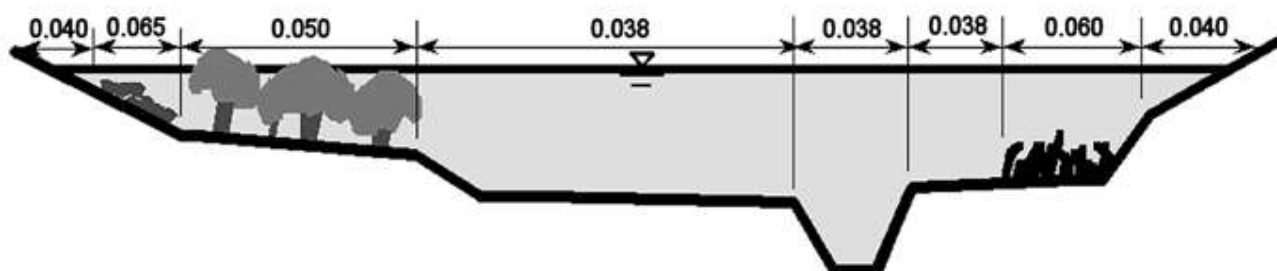

Figure 5.5 - Cross section subdivision



This phenomenon can occur in any type of conveyance computation, including the step backwater method. Computer logic can be seriously confused if a switchback were to occur in any cross section being used in a step-backwater program. For this reason, the cross section should always

be subdivided with respect to both vegetation and geometric changes. Note that the actual n value itself may be the same in adjacent subsections.

5.4 Roadside and Median Channel Guidelines and Criteria

5.4.1 Design Storms

Roadside median channel design should be based on the 10-year storm for interstate systems and full access controlled roadways. The maximum spacing for median drop inlets should be 500 feet in tangent, and 300 feet in curved sections. All other roadside channels (roadway, berm, surface, and outfall) should be designed based on the 25-year storm. The channel should be provided with sufficient capacity that the design high water elevation will be below the bottom of the subgrade nor should the travel way be encroached upon during the 50-year storm event. In depressed (sag) areas, all channels should be designed for the 50-year storm event. In situations where the channels may drain slowly or high water depths may be sustained for several hours, the designer may wish to use a higher design storm frequency to provide additional protection for the subgrade of the roadway. (5-6)

Temporary roadside and median channels used for erosion prevention and sediment control should be designed for the 2-year storm event.

5.4.2 Channel Shape and Protection

Roadside channels are typically trapezoidal or V-shaped in cross section and lined with grass or other protective linings, such as riprap. Refer to the “Elements of Channel Sections” figure in the USDA National Engineering Handbook, Section 5 for typical geometries for various channel sections. The shape of a roadside channel is governed largely by the geometric and safety standards applicable to the project. These channels should accommodate the design runoff in a manner that assures the safety of the motorist and minimizes future maintenance, damage to adjacent properties, and adverse environmental or aesthetic effects. Section 5.6 addresses safety issues related to open-channel drainage facilities.

Protective channel linings are an important aspect of any transportation project. Lining in a channel requires permanent or semi-permanent type erosion control measures to protect the channel from degradation. The most commonly implemented measures being grass channel lining, concrete channel lining, riprap channel lining, or turf reinforced mats (TRMs). Transitions between channels of dissimilar materials will also warrant protection from scour and erosion. For example, a concrete-lined channel transitioning to a vegetated channel would likely warrant a riprap-lined portion at the transition. It is the responsibility of the design engineer to check these areas for proper erosion control measures, both permanent and temporary. See chapter 9 for details on erosion control. For proper design of channel protection for roadside channels, use the Department’s channel protection design program (hosted by Georgia Tech <http://liningdesign.ce.gatech.edu>).

5.4.3 Channel Alignment

Roadside channels will parallel the roadway alignment and lie within the limits of the right-of-way of the roadway.

Changes in alignment should be as gradual as the right-of-way and terrain permit. Whenever practicable, changes in alignment should be made in sections with flatter grades where flow is subcritical.

5.4.4 Channel Grade

The following guidelines and design criteria should be followed when considering the grade required for a channel:

- Grade on surface channels at the top of cut slopes will be controlled primarily by the contour of the land. Surface channels should be constructed approximately 2-feet deep with low points draining into roadway channels by use of pipes down the back slope.
- Grade on grass-lined channels should be 0.3% minimum and preferably not less than 0.5% with the grade kept as constant as practicable.
- Grade affects both the size of the channel required to carry a given flow and the velocity at which the flow occurs. The flow should be kept subcritical wherever possible in order to minimize soil erosion.
- Alignment changes should be kept to a minimum for paved channels on steep slopes flowing in a supercritical flow regime.

5.4.5 Stream-Bank Protection from Erosion

Stream-bank stabilization shall be provided, when appropriate, as a result of any stream disturbance and shall include both upstream and downstream banks as well as the local site. The choice of stabilization used should be appropriate from an engineering and environmental aspect.

5.4.6 Typical Design Data Required

The following list includes data required for a typical design:

- Field measured topography or digital terrain model (DTM)
- Stream profile and cross sections
- Contour maps, quadrangle maps
- Soil survey and soil erosion index
- Determination of the design runoff volume or discharge
- Drainage basin size and characteristics
- C or CN Factors
- Rainfall intensity
- Available recorded data – gage station
- Regulatory flood data

5.5 Roadside and Median Channel Design Procedures

The primary function of roadside channels is to collect surface runoff from the highway and areas that drain to the right-of-way and convey the accumulated runoff to acceptable outlet points.

A secondary function of a roadside channel is to drain subsurface water from the base of the roadway to prevent saturation and loss of support for the pavement or to provide a positive outlet for subsurface drainage systems such as pipe underdrains.

Median channels perform the same functions as roadside channels and shall be designed using the same criteria.

Basic design steps, as adapted from HEC-22, are as follows:

Step 1 Establish a conceptual roadway plan

- Collect available site data
- Obtain or prepare existing and proposed plan and profile layout

Step 2 Obtain or establish cross section data

- Provide channel depth adequate to drain subbase
- Select channel side slopes based on safety clear zone, economics, soil stability, and access. Reference the GDOT Design Policy Manual for more policy-based guidelines <http://www.dot.ga.gov/PartnerSmart/DesignManuals/DesignPolicy/GDOT-DPM.pdf>
- Establish bottom width or shape of channel
- Identify features which may restrict cross section design, e.g., right-of-way constraints, environmentally sensitive areas, utilities, and existing drainage facilities

Step 3 Determine channel grades

- Plot initial grades on plan and profile layout
- Provide minimum grade of 0.3% to minimize ponding and sediment accumulation
- Consider influence of grade on lining type. Designer is to reference chapter 10 for lining design criteria.

Step 4 Check flow capacities and adjust as necessary

- Compute the design discharge at the downstream end of channel segment
- Set preliminary values of channel size, roughness coefficient, and slope
- Determine maximum allowable depth of channel including freeboard.
- Check flow capacity using Manning's equation and the slope area method
- If capacity is inadequate make adjustments as appropriate, e.g., increase bottom width, make channel side slopes flatter, make channel slope steeper, provide smoother channel lining
- Provide smooth transitions at changes in channel cross section

Step 5 Analyze outlet points and downstream effects

- Identify any adverse impacts such as increased flooding or erosion to downstream properties
- Mitigate any adverse impacts
- In order to obtain the optimum roadside channel system design, it may be necessary to perform several trials of the above procedure before a final design is achieved.

5.6 Safety

The GDOT hydraulic design criteria and policy found in each design chapter meet the primary responsibility for traffic safety which is to provide drainage structures which convey floodwaters and which avoid hazardous flooding and failure of the highway. Another important responsibility is to locate drainage structures so that they will present a minimum hazard to traffic. (5-1)

Drainage structures shall be located to present a minimum hazard to traffic and people or protected, if appropriate, using GDOT Construction Standards and Details available at:

<http://mydocs.dot.ga.gov/info/gdotpubs/ConstructionStandardsAndDetails/Forms/AllItems.aspx>.

Roadside channels that are outside of the clear zone can be designed with a trapezoidal cross section that has side slopes as steep as 2H:1V. (See GDOT construction Detail D-7 for berm ditches, side ditches and surface ditches). If protection is needed, see GDOT Construction Detail D-10 for 4-inch ditch paving.

For applications within the clear zone, see *AASHTO's Roadside Design Guide* for additional information. Channels that are within the clear zone and are not screened by guard rail shall be designed to be traversable using Figure 5.6. This figure shows the AASHTO recommended foreslopes and backslopes for traversable channel configurations.

Figure 5.6 - Traversable channel geometry for rounded channels with a bottom width greater than 8 feet or trapezoidal channels with a bottom width equal to or greater than 4 feet.
 Source: AASHTO Roadside Design Guide

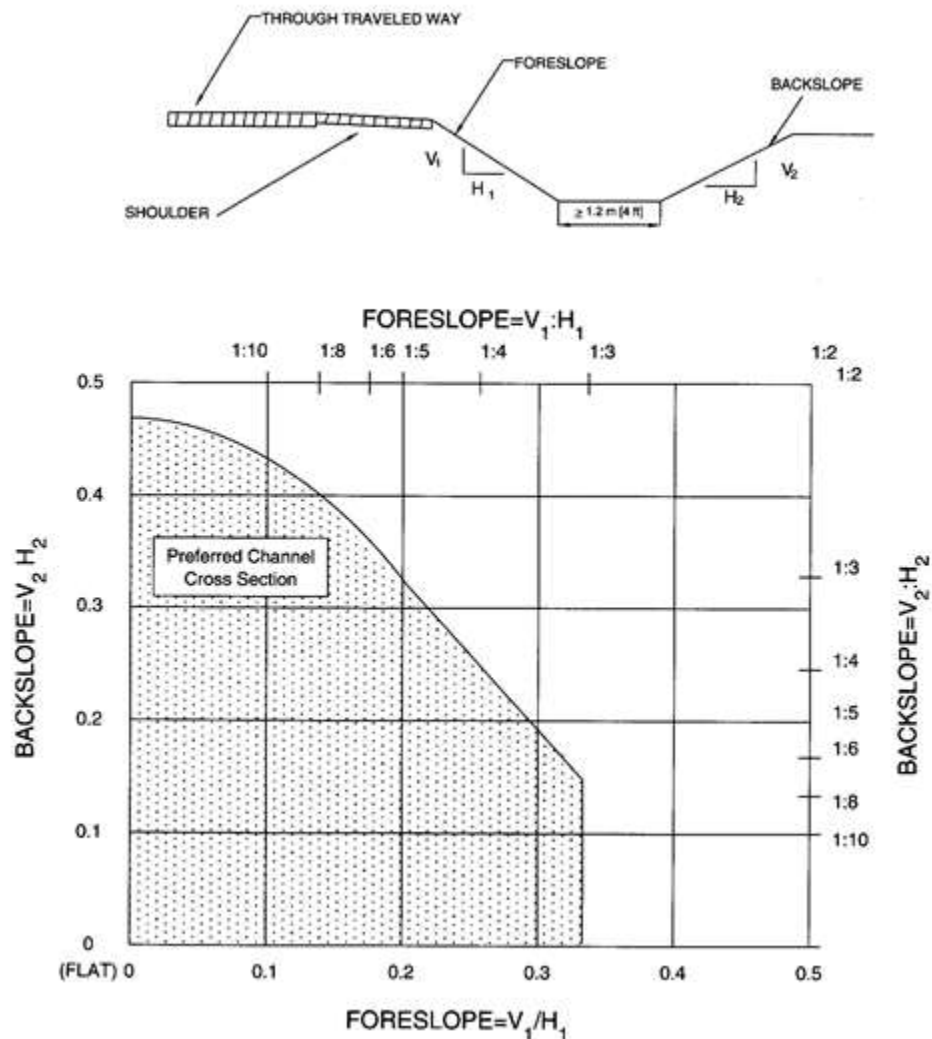

Channel sections that fall outside the shaded region of Figure 5.6 are not desirable and their use should be limited where high-angle encroachments might occur, such as the outside of relatively sharp curves. Channel sections outside the shaded region may be acceptable for projects with restrictive right-of-way, resurfacing, restoration, or rehabilitation (3R) construction projects, or on low-volume or low-speed roads, particularly if the bottom and backslopes do not have any fixed objects.

Chapter 5 References

1. American Association of State Highway and Transportation Officials (AASHTO). 2007. Highway Drainage Guidelines, 4th Ed.
2. Arcement, G.J., Schneider, V.R., USGS, 1984, [Guide for Selecting Manning's Roughness Coefficients for Natural Channels and Flood Plains](#). TS-84-204. Federal Highway Administration (FHWA), U.S. Department of Transportation, Washington, D.C.
3. Davidian, Jacob. United States Geological Survey (USGS). 1984. [Computation of Water-Surface Profiles in Open Channels](#).
4. Federal Highway Administration. 1961, Design Charts for Open-Channel Flow, [Hydraulic Design Series No. 3](#), FHWA-EPD-86-102. Federal Highway Administration (FHWA), U.S. Department of Transportation, Washington, D.C.
5. Schall, James D., Richardson, Everett V., Morris, Johnny L. 2008, Introduction to Highway Hydraulics, [Hydraulic Designs No. 4](#), FHWA-NHI-08-090. Federal Highway Administration (FHWA), U.S. Department of Transportation, Washington, D.C.
6. Tennessee Department of Transportation (TDOT). 2013. [Drainage Manual](#). Roadway Design Division.
7. United States Army Corps of Engineers (USACE). 1986. [Accuracy of Computed Water Surface Profiles](#). The Hydrologic Engineering Center, Davis, CA.
8. United States Army Corps of Engineers (USACE). 2010. HEC-RAS, River Analysis System, [Hydraulic Reference Manual](#). The Hydrologic Engineering Center, Davis, CA, Version 4.1
9. United States Department of Agriculture (USDA). National Resources Conservation Service (NRCS). National Engineering Handbook (NEH) [Hydraulics Section 5](#)

Chapter 6. Pavement Drainage - Contents

Chapter 6.	Pavement Drainage - Contents.....	6-i
6.1	Guidelines.....	6-1
6.1.1	Introduction.....	6-1
6.1.2	Hydroplaning	6-1
6.2	Gutter Spread and Design Storm Frequency	6-6
6.2.1	Gutter Spread.....	6-6
6.2.2	Design Storm Frequency.....	6-7
6.3	Gutter Flow	6-9
6.3.1	Longitudinal Slope - Gutter Grades.....	6-9
6.3.2	Cross Slopes	6-9
6.4	Gutter Flow Computations.....	6-10
6.4.1	Uniform Cross Section Procedure.....	6-11
6.4.2	Composite Cross Slopes.....	6-12
6.4.3	V-Sections	6-14
6.5	Inlet Types	6-14
6.5.1	Characteristics and Uses of Inlets.....	6-15
6.5.2	Inlet Flow Capacity and Interception	6-16
6.6	Design Procedures	6-29
6.6.1	Collect and Analyze Existing Data	6-29
6.6.2	Preliminary Layout - Placement of Inlets Due to Geometric Controls	6-29
6.6.3	Determine Drainage Areas and "Q's"	6-30
6.6.4	Placement of Inlets on Continuous Grades.....	6-31
6.6.5	Low Point and Flanking Structures.....	6-31
Chapter 6	References.....	6-35

Chapter 6. Pavement Drainage

6.1 Guidelines

Good drainage design entails properly balancing technical principles and data with the environment while giving due deliberation to other factors including safety, function, and cost. Effective drainage of highway pavements is essential to the maintenance of highway service levels and to traffic safety. Water on the pavement can interrupt traffic, reduce skid resistance, increase potential for hydroplaning, and limit visibility due to splash and spray. [\(6-3\)](#)

Pavement drainage requires consideration of surface drainage, gutter flow, and inlet capacity. The design of these elements is dependent on storm frequency and the allowable spread of stormwater on the pavement surface. This chapter presents guidance for the design of these elements.

The guidelines included herein should be considered minimum standards. The designer should consistently strive to provide optimum and functional drainage facilities.

Plans, drainage profiles, and the quantities for the drainage system design should be developed in accordance with the current GDOT Plan Presentation Guide. [\(6-6\)](#)

6.1.1 Introduction

Roadway features considered during gutter, inlet, and pavement drainage calculations include the following:

- Longitudinal and cross slope
- Curb and gutter sections
- Pavement texture/surface roughness
- Roadside and median ditches
- Bridge decks

The pavement width, cross slope, profile and pavement texture control the time it takes for stormwater to drain to the gutter section. The gutter cross-section and longitudinal slope control the quantity of flow that can be carried in a gutter section.

6.1.2 Hydroplaning

The purpose for pavement drainage is to provide a safe roadway for the traveling public. Therefore, an important reason for removing water from the pavement is to minimize the potential for hydroplaning. For additional details on the hydroplaning phenomenon, see FHWA's HEC-22. [\(6-4\)](#)

Hydroplaning is not evaluated as a standard project design procedure. Depending on the roadway characteristics, gutter spread calculations are sufficient. For areas where crash rates are escalated during wet weather conditions, hydroplaning calculations may be necessary. The designer should also be aware of the potential for hydroplaning in areas with zero super elevation in a crest or sag, turn lanes, median openings, and any other areas susceptible to problems.

Hydroplaning conditions can be evaluated based upon the relationships between the following primary controlling factors:

- Vehicular speed
- Tire conditions (pressure and tire tread)
- Pavement micro and macrotexture
- Roadway geometrics (pavement width, cross slope, grade)
- Pavement conditions (rutting, depressions, roughness)

Vehicular speed appears as a significant factor in the occurrence of hydroplaning; therefore, it is considered to be the driver’s responsibility to exercise prudence and caution when driving during wet conditions. (6-2) This is analogous to the prudence and caution that drivers must exercise when ice or snow is on the roadway.

The following guidance is taken from FHWA *Hydraulic Engineering Circular No. 21*. (6-4) The prevention of hydroplaning is based on pavement and geometric design criteria for minimizing hydroplaning. An empirical equation for the vehicle speed that initiates hydroplaning is:

$$V_a = SD^{0.04} P_t^{0.3} (TD + 1)^{0.06} A_T \tag{6.1}$$

where A_T is a Texas Transportation Institute empirical curve fitting relationship. A_T is the greater of A_{T1} and A_{T2} , where

$$A_{T1} = \frac{10.409}{d^{0.06}} + 3.507 \text{ and } A_{T2} = \left[\frac{28.952}{d^{0.06}} - 7.817 \right] TXD^{0.14} \tag{6.2}$$

Where:

- V_a = Vehicle speed, mph
- SD = Spindown (percent); hydroplaning is assumed to begin at 10% spindown. This occurs when the tire rolls 1.1 times the circumference to achieve a forward progress distance equal to one circumference.
- P_t = Tire pressure, psi
- TD = Tire read depth (1/32 in)
- d = Water film depth, in
- TXD = Pavement texture depth, in

For given values of V_a , SD , P_t , TD , and TXD , Equations (6.1) and (6.2) can be solved simultaneously for film depth, d .

For example, given the following parameters, d is estimated to be 0.0735 in.

- V_a = 55 mph
- SD = 10% (by definition)
- P_t = 27 psi (50 percentile level)

TD = 7/32 in (50 percentile level)

TXD = 0.038 in (mean pavement texture depth)

This value of d (0.0735 in) is suggested as a sound design value, since it represents the combination of the mean or median of all the above parameters. However, a designer could adjust the values of the target design parameters to match the anticipated prevailing road conditions for a given project.

For example, a designer might groove a deck to increase TXD, which would increase the water film depth, d , at which hydroplaning would be expected to occur at the design speed. Or, a designer might adjust the parameters to design for a smaller d at higher vehicle speeds. Multiple combinations of adjustments can be made to the parameters to control the design for hydroplaning.

Once a design d is determined, it is assumed that the thickness of the water film on the pavement should be less than d . Water flows in a sheet across the surface to the edge of the gutter flow. The length of sheet flow is designated as L_f . At the edge of the gutter flow, the design hydroplaning depth is d .

By combining the rational equation, the Manning's equation, and Equations (6.1) and (6.2), Equation 6.3 solves for the rainfall intensity that will cause hydroplaning.

$$i = \left[\frac{64904.4}{C n} \right] \left[\frac{S_x}{(S_x^2 + S^2)^{0.25}} \right] \left[\frac{d^{1.67}}{L_f} \right] \quad (6.3)$$

Where:

C = Runoff coefficient from rational equation, (dimensionless)

n = Manning's coefficient for pavement, (.016)

S_x = Pavement cross slope (ft/ft)

S = Longitudinal slope, (ft/ft)

d = Design hydroplaning depth depending on speed, (in)

L_f = Travel distance across the pavement for water flow, (feet)

The rainfall intensity, related to hydroplaning, is independent of the storm event frequency. Tables 6.1 and 6.2 present hydroplaning design rainfall intensities for vehicle speeds of 55 and 65 mph, respectively.

Table 6.1. Hydroplaning rainfall intensity

**i (in/hr), for V = 55 mph (hydroplaning sheet flow depth d = 0.08 in)
[n = 0.016 C = 0.9 TXD = 0.038 in].**

S	S _x	Travel Distance L _r			
		24	36	48	58
0.01	0.01	3.7	2.5	1.9	1.5
	0.02	5.9	4.0	3.0	2.5
	0.04	8.7	5.8	4.4	3.6
	0.06	10.8	7.2	5.4	4.5
	0.08	12.5	8.3	6.2	5.1
0.02	0.01	3.0	2.0	1.5	1.2
	0.02	5.3	3.5	2.6	2.2
	0.04	8.4	5.6	4.2	3.5
	0.06	10.6	7.1	5.3	4.4
	0.08	12.3	8.2	6.2	5.1
0.04	0.01	2.2	1.5	1.1	0.9
	0.02	4.2	2.8	2.1	1.7
	0.04	7.5	5.0	3.7	3.1
	0.06	9.9	6.6	5.0	4.1
	0.08	11.8	7.9	5.9	4.9
0.06	0.01	1.8	1.2	0.9	0.7
	0.02	3.5	2.4	1.8	1.5
	0.04	6.6	4.4	3.3	2.7
	0.06	9.1	6.1	4.6	3.8
	0.08	11.2	7.5	5.6	4.6
0.08	0.01	1.6	1.0	0.8	0.7
	0.02	3.1	2.1	1.5	1.3
	0.04	5.9	4.0	3.0	2.5
	0.06	8.4	5.6	4.2	3.5
	0.08	10.5	7.0	5.3	4.4

Table 6.2. Hydroplaning rainfall intensity					
i (in/hr), for V = 65 mph (hydroplaning sheet flow depth d = 0.047 in). [n = 0.016 C = 0.9 TXD = 0.038 in]					
S	S _x	Travel Distance L _r			
		24	36	48	58
0.01	0.01	1.5	1.0	0.8	0.6
	0.02	2.4	1.6	1.2	1.0
	0.04	3.5	2.4	1.8	1.5
	0.06	4.4	2.9	2.2	1.8
	0.08	5.0	3.4	2.5	2.1
0.02	0.01	1.2	0.8	0.6	0.5
	0.02	2.1	1.4	1.1	0.9
	0.04	3.4	2.3	1.7	1.4
	0.06	4.3	2.9	2.1	1.8
	0.08	5.0	3.3	2.5	2.1
0.04	0.01	0.9	0.6	0.4	0.4
	0.02	1.7	1.1	0.8	0.7
	0.04	3.0	2.0	1.5	1.2
	0.06	4.0	2.7	2.0	1.7
	0.08	4.8	3.2	2.4	2.0
0.06	0.01	0.7	0.5	0.4	0.3
	0.02	1.4	1.0	0.7	0.6
	0.04	2.7	1.8	1.3	1.1
	0.06	3.7	2.5	1.8	1.5
	0.08	4.5	3.0	2.3	1.9
0.08	0.01	0.6	0.4	0.3	0.3
	0.02	1.2	0.8	0.6	0.5
	0.04	2.4	1.6	1.2	1.0
	0.06	3.4	2.3	1.7	1.4
	0.08	4.3	2.8	2.1	1.8

Designers do not have control over all factors involved in hydroplaning. However, the following practical remedial measures should be considered by the designer during development of a project to reduce hydroplaning potential:

Pavement Sheet Flow

- Maximize transverse slope
- Maximize pavement roughness
- Use of graded course (porous pavements)

Gutter Flow

- Limit gutter spread (by decreasing inlet spacing)
- Maximize interception of gutter flow above superelevation transitions

Sag Areas: Limit ponding duration and depth.

Overtopping: Limit depth and duration of overtopping flow.

If suitable measures cannot be implemented to address an area of high potential for hydroplaning or an identified existing problem area, the installation of advance warning signs, although not common, could be considered as a last course of action.

The above measures are in accordance with chapter 9 of the AASHTO Highway Drainage Guidelines. [\(6-2\)](#)

6.2 Gutter Spread and Design Storm Frequency

Following are two of the more significant variables that must be considered in the design of highway pavement drainage:

- the allowable gutter spread
- the frequency of the design storm event

Gutter spread and design storm frequency are interrelated variables.

6.2.1 Gutter Spread

Gutter spread is defined as the perpendicular distance from the face of curb or barrier to the furthest extent of the water on the roadway during the design storm (Figures 6.1 and 6.2). Gutters serve an important function to carry water and reduce gutter spread. Removal of the gutter for a project on NHS or State Route will require the approval of the Office of Design Policy and Support's Hydraulic Section.

Limiting the gutter spread width is a very important design criterion and will vary depending on the roadway classification and speed of traffic. Gutter spread shall be limited to the widths shown in Table 6.3.

Figure 6.1 - Gutter spread in a typical urban section

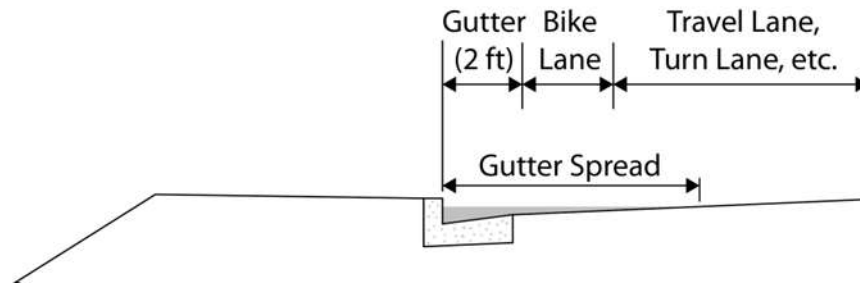
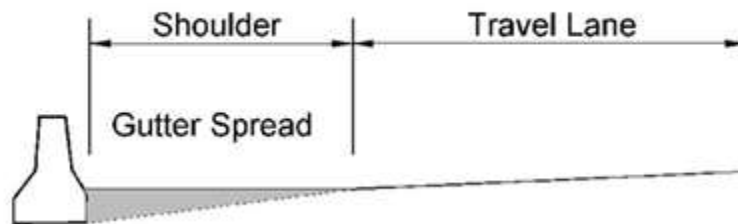

Figure 6.2 - Gutter spread confined to a shoulder on an interstate



6.2.2 Design Storm Frequency

Inlet spacing should be designed to accommodate the gutter spread limits given in Table 6.3.

Inlets and drainage systems at locations, such as depressed sections and underpasses where ponded water can be removed only through the storm drainage system, should be designed to the 50-year frequency storm event so that drainage structures are not hydraulically surcharged. [\(6-4\)](#)

The use of a less frequent events, such as a 100-year storm, to assess hazards at critical locations where water can pond to appreciable depths is commonly referred to as a check storm or check event. [\(6-4\)](#)

A check storm should be used any time runoff could cause unacceptable flooding during less frequent events. Inlets should always be evaluated for a check storm when a series of inlets terminates at a sag vertical curve where ponding to hazardous depths could occur. [\(6-4\)](#)

The criterion for gutter spread is that one lane of traffic should remain open during the check storm event with a reasonable depth of water on the pavement (0.5 feet).

At low points where stormwater can exit the roadway by overtopping the curb without the occurrence of significant ponding, it is typically not necessary to design the drainage system to the 50-year storm event or to evaluate the performance of the system using a check storm event.

Table 6.3 Vertical profile high-water marks for pavement

Facility	Curb-Opening Inlets		Grate Inlets	
	Max Gutter Spread (ft)	Design Frequency (yr)	Max Gutter Spread (ft)	Design Frequency (yr)
Pavement Drainage in <u>Sags</u>				
Interstates	All drainage confined to shoulder unless it can be safely released to the R/W	50	All drainage confined to shoulder unless it can be safely released to the R/W	50
State Routes > 45 mph	All drainage confined to shoulder unless it can be safely released to the R/W	50	All drainage confined to shoulder unless it can be safely released to the R/W	50
State Routes <= 45 mph	8	50	8	50
Hurricane Evacuation Routes <= 45 mph ¹	8	25	8	50
Nonstate Routes	8	10	8	10
Temporary Detours	8	10	8	10
Pavement Drainage <u>on Grade</u>				
Interstates	All drainage confined to shoulder unless it can be safely released to the R/W	10	All drainage confined to shoulder unless it can be safely released to the R/W	10
State Routes > 45 mph	All drainage confined to shoulder unless it can be safely released to the R/W	10	All drainage confined to shoulder unless it can be safely released to the R/W	10
State Routes <= 45 mph	1/2 lane width + gutter ²	10	8	10
Hurricane Evacuation Routes <= 45 mph	1/2 lane width + gutter ²	10	8	10
Nonstate Routes	1/2 lane width + gutter ²	10	8	10
Temporary Detours	1/2 lane width + gutter ²	10	8	10
Note: All storm events listed in this table are for 24-hour duration storm events. ¹ Nonstate Route only ² Entire width of bike lane may be included in allowable gutter spread.				

6.3 Gutter Flow

The basis for the gutter flow principles discussed in this chapter can be found in Section 4.3 of the HEC 22 [\(6-4\)](#) manual.

Gutter flow calculations are necessary to relate the total quantity of flow (Q) in the curbed channel to the spread of water on the shoulder, parking lane, or pavement section. For the purposes of this chapter, the term gutter refers not only to the typical 2-foot wide concrete gutter, but to the area covered by the water spread on the pavement. Two of the main components that influence gutter flow are the longitudinal and transverse (cross) slopes of the pavement. Longitudinal slope may also be referred to as gutter grade.

6.3.1 Longitudinal Slope - Gutter Grades

Longitudinal slope (grade) is important for curbed roadways (e.g., roadway shoulders with curb and gutter, v-gutters, concrete barrier walls, etc.), because stormwater runoff can accumulate and spread against the curb. It should be noted that flat slopes on uncurbed pavements can also lead to a spread problem if vegetation is allowed to build up along the pavement edge.

A minimum longitudinal gutter grade of 0.5% is desirable for curbed roadways, but a minimum grade of 0.3% may be used where the paved surface is accurately sloped and supported on firm subgrade. [\(6-1\)](#) Longitudinal grades less than 0.3% should be used only in extreme conditions such as increased road cross slope or decreased inlet spacing. [\(6-5\)](#)

A minimum longitudinal grade of 0.3% should be reached within approximately 50 ft of the level point on sag and crest vertical curves. This minimum criterion corresponds to a K value of 167 ft per percent change in grade (ft/%). Difficulty with routing the drainage away from the level point on crest vertical curves is typically not experienced when this criterion is met. [\(6-1\)](#)

Special attention to drainage should be exercised when flat sag or crest vertical curves are used (i.e., K value is greater than 167 ft/%). Varying or "rolling" the roadway profile can achieve minimum gutter grades in flat terrain. Varying the cross slope of the travel lanes and/or shoulders is another option to consider for facilitating drainage on a case by case basis. [\(6-1\)](#)

K values greater than 167 (ft/%) may be required to provide a safe sight distance on crest vertical curves for design speeds greater than 60 mph. This may be of particular concern for night driving on highways without lighting. [\(6-1\)](#)

6.3.2 Cross Slopes

The design of pavement cross slope is a compromise between the need for reasonably steep cross slopes for drainage and relatively flat cross slopes for driver comfort.

Typical practice is to provide a 2% pavement cross slope for travel lanes. Cross slope should be increased to 2.5% in areas where an increase is practicable and justified. On multi-lane roadways, the cross slope may be broken at 1% intervals not to exceed 4% on any lane. [\(6-5\)](#) Steeper cross slopes (4% maximum) should be considered for roadways draining more than three travel lanes in the same direction or in a 4-lane divided section where the gutter grade is less than 0.5%.

As a general rule, pavement cross slope should be at least 1% near vertical curve sag points and longitudinal grades should be at least 0.3% at locations where the pavement cross slope is flat (e.g., at superelevation transitions). (6-5)

Cross slopes on superelevated sections of roadway should typically not exceed 8% due to the hazards associated with snow and ice. However, superelevated cross slopes larger than 8% may be considered on a case-by-case basis for roadways (i.e., loop ramps).

6.4 Gutter Flow Computations

In establishing the capacity of the gutter flow for a given width of spread, the type of gutter is important. Three of the more common types of gutters are shown in Figure 6.3 (gutter spread is shown as the variable "T" in Figure 6.3).

Figure 6.3 - Common gutter types

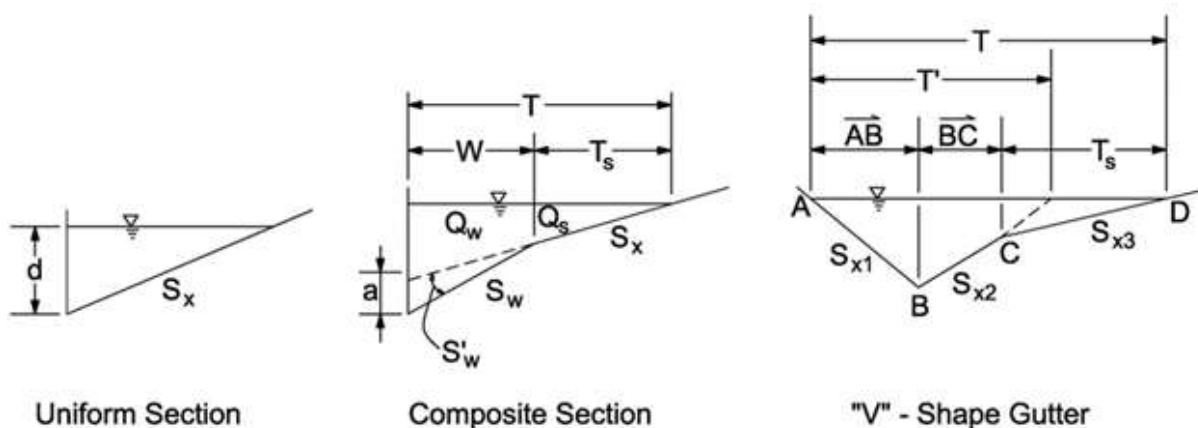

Figure 6.4 - Photograph of typical v-section gutter and inlet



The uniform and composite gutter shapes are more conventional. The V-shaped gutter (Figure 6.4) is often used in median areas and along shoulders where surface water runs onto the pavement. The composite gutter will carry more flow for a given width than the uniform gutter.

6.4.1 Uniform Cross Section Procedure

In calculating the flow capacity of gutters with a uniform cross slope, a modified version of Manning's equation is used.

$$Q = \frac{0.56}{n} S_x^{1.67} S_L^{0.5} T^{2.67} \quad (6.4)$$

Rearranged to solve for gutter spread (T), this equation is expressed as

$$T = \left(\frac{Qn}{0.56 S_x^{1.67} S_L^{0.5}} \right)^{0.375} \quad (6.5)$$

Where:

- Q = Total flow rate, ft³/s
- n = Manning's coefficient
- S_x = Pavement cross-slope, ft/ft
- S_L = Longitudinal slope, ft/ft
- T = Width of flow (gutter spread), ft

The resistance of the curb face is negligible and is therefore not accounted for in Equation 6.4.

Manning's n Coefficient for Pavements

The roughness of the pavement surface affects water spread. The methods for determining spread provided in this chapter use Manning's roughness coefficient (n). Normally a value of 0.016 is used for curb and gutter flow. [\(6-4\)](#)

Table 6.4 provides additional Manning's roughness coefficients for specific types of pavement conditions.

Table 6.4. Manning's n for street and pavement gutters	
<i>Type of Gutter or Pavement</i>	Manning's n
Concrete Gutter, troweled finish	0.012
Asphalt Pavement: Smooth texture	0.013
Rough texture	0.016
Concrete Gutter, Asphalt Pavement Smooth texture	0.013
Rough texture	0.015
Concrete Pavement Float finish	0.014
Broom finish	0.016
For gutters with small slope, where sediment may accumulate, increase above n values by:	0.002
Source: Reference (6-4)	

For depth of flow, in feet, at curb (d):

$$d = T S X \tag{6.6}$$

There are numerous ways of solving Equation 6.5 to find gutter spread, T. Some common and practical methods are:

- Model the system in the FHWA's Hydraulic Toolbox 4.07 software, available at <http://www.fhwa.dot.gov/engineering/hydraulics/software.cfm>.
- Model the system in a HEC 22 based computer program such as StormCAD or FlowMaster, both by Bentley Systems (Haestad Methods). The User Guides for these programs contain concise and practical guidance on gutter flow and pavement drainage in general with reference to the FHWA's HEC 22. [\(6-4\)](#) They are available for free download at <docs.bentley.com/line.php>.

6.4.2 Composite Cross Slopes

Pavements with composite cross slopes are composed of a pavement section with a cross slope that is different from the gutter cross slope. Figure 6.5 depicts a typical composite cross slope section.

Figure 6.5 - Typical pavement with composite cross slope

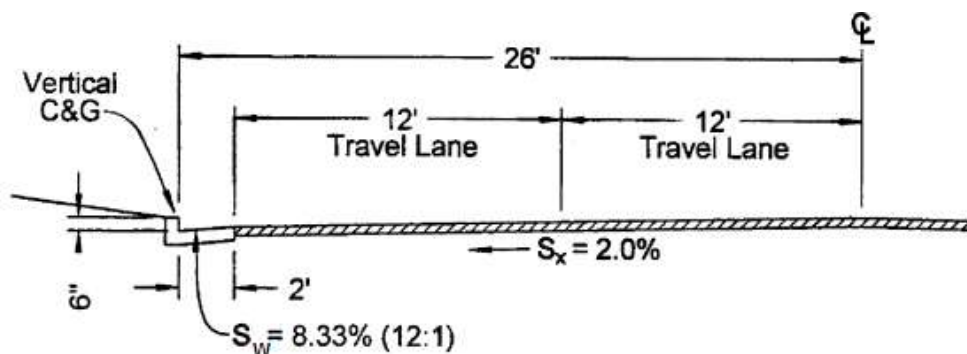

For pavement with composite cross slopes, the total rate of flow in the channel may be expressed as the sum of the flow in the gutter section (Q_w) and the flow outside of the gutter section (Q_s):

$$Q = Q_w + Q_s \tag{6.7}$$

The total flow Q may also be expressed as:

$$Q = \frac{Q_s}{(1 - E_o)} \tag{6.8}$$

Where E_o (gutter flow ratio) is defined as the ratio of the flow in the width of the gutter section (Q_w) to the total channelized pavement flow (Q):

$$E_o = \frac{Q_w}{Q} \tag{6.9}$$

Further, E_o can be determined using the below expressed relationship between S_w , S_x , T , and W :

$$E_o = \frac{1}{1 + \frac{\frac{S_w}{S_x}}{\left(1 + \frac{S_x}{\frac{T}{W} - 1}\right)^{2.67}} - 1} \tag{6.10}$$

Where:

- E_o = Gutter flow ratio (Q_w/Q)
- S_w = Gutter slope (ft/ft)
- S_x = Pavement cross-slope (ft/ft)

T = Width of flow (gutter spread), ft

Note:

S_w is defined as $S_x + a/W$, where a = gutter depression depth at inlet (ft) and W = width of the gutter or grate (ft). See the composite section in Figure 6.3 or Figure 6.8 for a graphical depiction of a and W .

6.4.3 V-Sections

V-sections are used where curbs are not needed or may present a safety problem. When solving for S_x , Equation 6.11 may be used. ⁽⁶⁻⁴⁾

$$S_x = \frac{S_{x1} S_{x2}}{S_{x1} + S_{x2}} \quad (6.11)$$

S_{x1} and S_{x2} are defined in the V-shaped gutter graphic shown in Figure 6.3.

6.5 Inlet Types

Inlets used for the drainage of pavement surfaces can be divided into four major classes. These classes are as follows:

- Grate inlets (GA STD 1019A Types A, B, C and D; GA STD 1019B Type V-2; GA STD 5001M; GA DETAIL D-33)
- Curb opening inlets (all GA STD 1033 and 1034 series)
- Slotted drains (GA DETAIL D-27)
- Combination inlets (GA STD 1010, GA STD 1013, GA STD 1019A Type E, GA STD 1019B Type V-1)

Construction details for the above listed inlets can be found on Georgia's Department of Transportation web site at

<http://mygdot.dot.ga.gov/applications/gdotpubs/ConstructionStandardsAndDetails/Forms/AllItems.aspx>

Figure 6.6 - Inlet types used in roadway drainage design

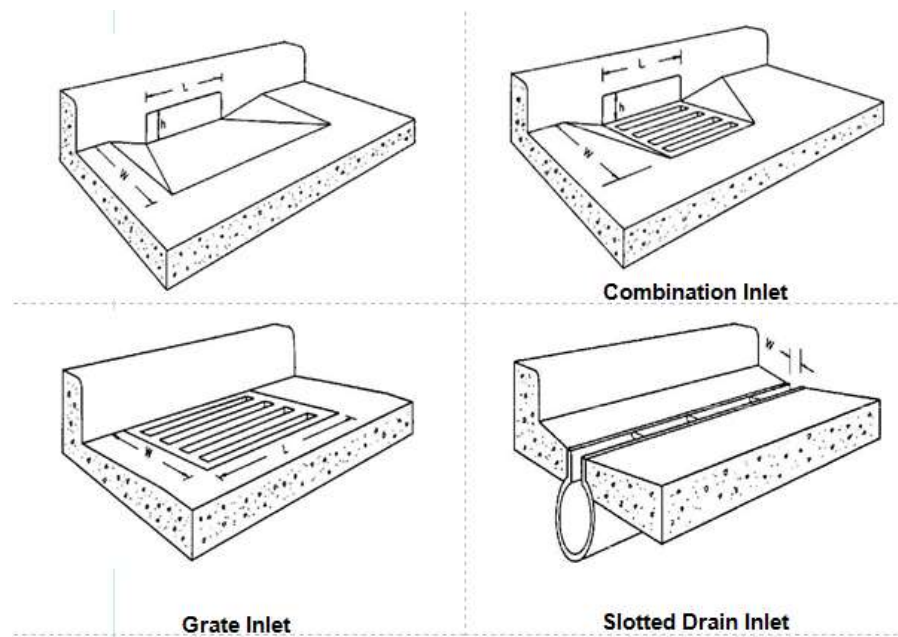

6.5.1 Characteristics and Uses of Inlets

The inlets covered in this section are drainage structures used to collect surface water adjacent to curbs or barrier walls where gutter spread must be evaluated and controlled.

Curb-Opening Inlets

Curb-opening inlets are vertical openings in the curb covered by a top slab. They can convey large quantities of water and debris. They are less susceptible to clogging than slotted drains and grate inlets, and preference should be given to their use in sags. A caveat to this general rule is that grate inlets or combination inlets are preferable in heavily urbanized areas. Curb-opening inlets are generally not recommended for use on steep continuous grades.

Combination Inlets

Curb-opening and combination inlets are common. Slotted inlets are also used in combination with grates, located either longitudinally upstream of the grate or transversely adjacent to the grate. Engineering judgment is necessary to determine if the total capacity of the inlet is the sum of the individual components or a portion of each. The longitudinal pavement grade, cross slope and proximity of the inlets to each other will be deciding factors. Combination inlets are more desirable than grate inlets in sags because they can continue to receive stormwater flow when the grate becomes clogged. Metal-hooded combination inlets should be used in radii to prevent crushing.

Capacity Calculations for Combination Inlets

- For combination inlets on grade, the designer should only use the grate component for capacity calculations.
- For combination inlets in a sag location, the designer should use the hood and grate components of the inlet for capacity calculations. Also use a 50% efficiency factor to account for potential clogging of the inlet.

Grate Inlets

Grate inlets consist of an opening in the gutter covered by one or more grates. They are best suited for use on continuous grades. Because they are susceptible to clogging with debris, the use of standard grate inlets at sag points should be limited to minor sag point locations without debris potential. A major sag point is a location where water will pond 1 foot or more when the sag inlet is clogged. Special-design (oversized) grate inlets can be utilized at major sag points if sufficient capacity is provided for clogging. In this case, flanking inlets are definitely recommended. Grates should be bicycle safe, where bicycle or wheel chair traffic is anticipated and structurally designed to handle the appropriate loads when subject to traffic. Grates shall not be placed in the travel way on National Highway System (NHS) or state routes. Because of higher speeds special consideration is given to limited access highways. For these facilities Georgia Construction Standard Detail 5001M shall be used on the inside shoulder where the shoulders are 4.5 feet or wider and bicycles are prohibited. All grates shall have anti-theft devices as approved by the Office of Design Policy and Support. All grates shall be located in the shoulder and not within the travel lane. Grates shall be oriented parallel with the flow of traffic where bicycles are prohibited. Curb and gutter on a NHS route or state route shall not be replaced with header curb. Exceptions to the above stated policies on limited access highways shall require approval by the Office of Design Policy and Support. Storm systems should be designed to control gutter spread under the assumption that grates are 50% clogged.

Slotted Drain Inlets

These inlets consist of a slotted opening with bars perpendicular to the opening. Slotted inlets function as weirs with flow entering from the side. They can be used to intercept sheet flow, collect gutter flow with or without curbs, modify existing systems to accommodate roadway widening or increased runoff, and reduce ponding depth and spread at grate inlets. The two types of slotted inlets in use are the vertical riser type and the vane type. Note that slotted drains are not recommended for use in sags since they are more easily clogged than other inlet types. Slotted drain inlets can be used on curbed or uncurbed sections.

6.5.2 Inlet Flow Capacity and Interception

The interception capacity of a slotted drain inlet, curb-opening inlet or grate inlet on grade is equal to the efficiency of the inlet multiplied by the total flow:

$$Q_i = EQ \quad (6.12)$$

Several computer modeling software packages are available to perform inlet capacity calculations, such as FHWA's Hydraulic Toolbox, StormCAD, and FlowMaster. GDOT does not specify a particular method be used, but does request that the results be included on the standard GDOT results form for ease of review.

Curb-Opening Inlets and Slotted Drains on Grade

Flow interception by slotted inlets and curb-opening inlets is similar in that each is a side weir and the flow is subjected to lateral acceleration due to the cross slope of the pavement. Analysis of data from the FHWA tests of slotted inlets with slot widths ≥ 1.75 in indicates that the length of slotted

inlet required for total interception can be computed by Equation 6.13. Chart 6.3, is therefore applicable for both curb-opening inlets and slotted inlets. Similarly, Equation 6.14 is also applicable to both curb-opening inlets and slotted inlets. [\(6-4\)](#)

Figure 6.7 - Curb inlet placed on continuous roadway grade



When slotted drains are used to capture overland flow, research has indicated that with water depths ranging from 0.38 in to 0.56 in, the 1, 1.75 and 2.5 in wide slots can accommodate 0.025 ft³/s /ft with no splash-over for slopes from 0.5% to 9%. At a test system capacity of 0.40 ft³/s /ft, a small amount of splash over occurred. Within these ranges, slotted inlets are equivalent in efficiency to curb-opening inlets. When these depths and flow rates greater than the maximum values in the range, curb-opening inlets are more efficient and should be specified rather than slotted drains. [\(6-4\)](#)

Curb-opening inlets are preferable to grate inlets in locations where grates would be in traffic lanes, where greater debris handling capability is required, and where it is desirable to provide a smooth path for bicycle traffic (e.g., a narrow shoulder).

Both curb-opening inlets and slotted drain inlets offer little interference to traffic operations. [\(6-4\)](#)

Non-Depressed Curb-Opening Inlets and Slotted Drains on Grade

The length of a non-depressed curb-opening inlet (i.e., uniform section) required for total interception of flow on a pavement section with a straight cross slope is expressed by the following:

$$L_T = KQ^{0.42}S_L^{0.3}(1/nSX)^{0.6} \quad (6.13)$$

Where:

- L_T = Curb-opening length required to intercept 100% of gutter flow, ft
 K = 0.6

For composite cross slopes, substitute S_e for S_x where $S_e = S_x + S'_w E_o$ and $S'_w = a/W$.

The efficiency of curb-opening inlets shorter than the length required for total interception is expressed by:

$$E = 1 - (1 - L/LT)^{1.8} \tag{6.14}$$

Where:

$L =$ Curb-opening length (shorter than LT), ft

Depressed Curb-Opening Inlets and Slotted Drains on Grade

The length of inlet necessary for required interception by locally depressed curb-opening inlets or curb openings in continuously depressed gutter sections (i.e., composite cross slopes) can be found by the use of an equivalent cross slope, S_e , in Equation 6.15 in place of S_x :

$$S_e = S_x + S'_w E_o \tag{6.15}$$

Where:

$S'_w =$ Gutter cross slope measured from the pavement cross slope = a/W , ft/ft

$E_o =$ Ratio of flow in the gutter (or depressed) section to total gutter flow

$a =$ Gutter depression at inlet, ft

$W =$ Gutter width, ft

E_o is determined by the gutter configuration upstream of the inlet as discussed in the section on composite cross slope gutter flow computations.

Figure 6.8 - Definition sketch of S'_w

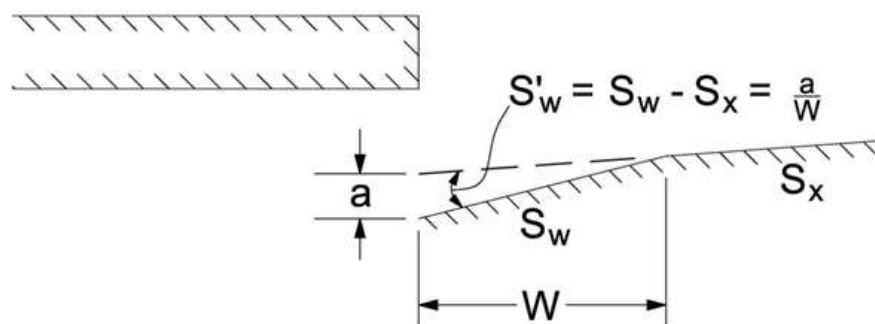

Curb Inlets in Sag

The capacity of a curb-opening inlet in a sag depends on water depth at the curb, the curb-opening length, and the height of the curb opening. The inlet operates as a weir to depths equal to the curb-opening height and as an orifice at depths greater than 1.4 times the opening height. At depths between 1.0 and 1.4 times the opening height, flow is in a transition stage.

Weir Flow for Depressed Curb-Opening Inlets in Sag

The equation for the interception capacity of a depressed curb-opening inlet operating as a weir ($d \leq h$) is:

$$Q_i = C_w(L + 1.8W)d^{1.5} \tag{6.16}$$

Where:

- $C_w = 2.3$
- $L =$ Length of curb opening, ft
- $W =$ Width of depression, ft
- $d =$ Depth of water at curb measured from water surface to the projected normal cross slope gutter flow line, ft

This weir equation uses an effective weir length and coefficient that is representative of the line of gutter transition to the depression. The user is cautioned not to use the depth from the water surface to the depressed inlet throat for d , but to use the un-depressed depth “ d ” (or more specifically, the projected depth at the curb face as shown in Figure 6.9. Otherwise, the capacity for weir flow will be overestimated.

Figure 6.9 - Definition of weir flow parameters used in Equation 6.16

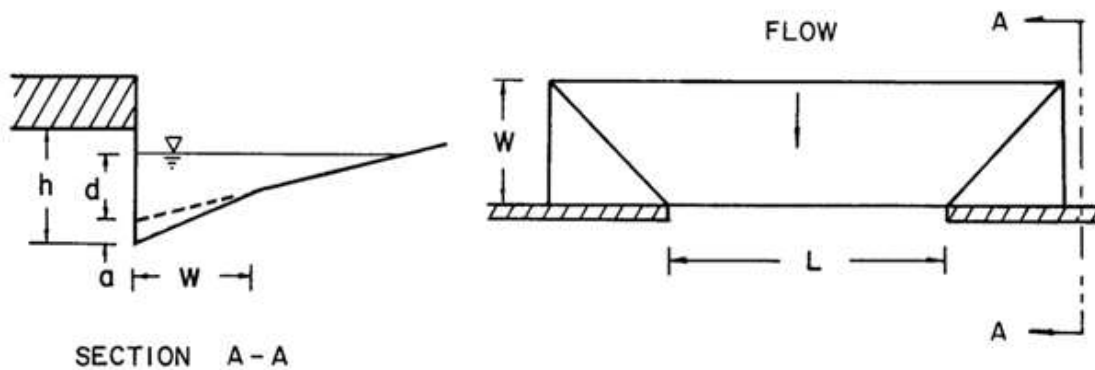

Weir Flow for Curb-Opening Inlets without Depression

The weir equation for curb-opening inlets without depression becomes

$$Q_i = C_w L d^{1.5} \tag{6.17}$$

Where:

- $C_w = 3.0$
- $L =$ Length of curb opening, ft
- $d =$ Flow depth, ft

Note: At curb-opening lengths greater than 12 ft, Equation 6.14 for a non-depressed inlet produces intercepted flows that exceed the values for depressed inlets computed using Equation 6.13. Since depressed inlets will perform at least as well as non-depressed inlets of the same length, Equation 6.14 should be used for all curb-opening inlets having lengths greater than 12 ft.

Orifice Flow for Curb-Opening Inlets

Curb-opening inlets operate as orifices at depths greater than approximately 1.4 times the opening height. The interception capacity can be computed by

$$Q_i = C_o A [2g (d_i - h/2)]^{0.5} \quad (6.18)$$

Where:

- C_o = Orifice coefficient (0.67)
- A = Clear area of curb opening = $h \times L$, where L is the horizontal length of curb opening, ft^2
- g = Acceleration of gravity, 32.2 ft/s^2
- d_i = Depth at lip of curb opening as defined in Figure 6.10, ft
- h = Height of curb-opening orifice as defined in Figure 6.10, ft
- d_o = Effective head at the centroid of the orifice, ft

See Figure 6.10 for a graphical depiction of the parameters used in this equation.

Figure 6.10 - Parameters for calculating orifice flow into an inclined curb inlet

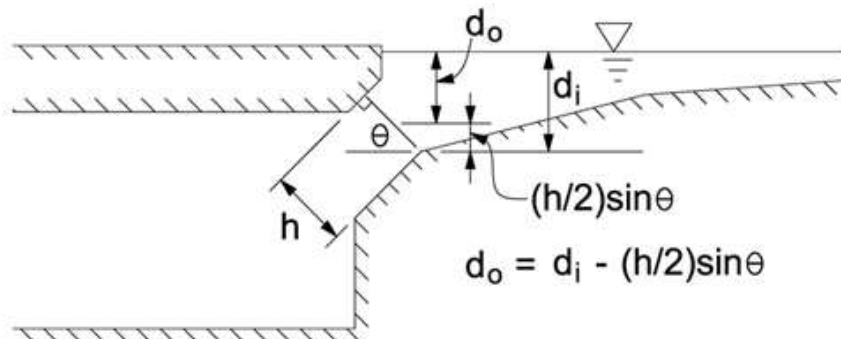

Slotted Drain Inlets in Sag

The use of slotted drain inlets in sag configurations is generally discouraged because of the propensity of these inlets to intercept debris and clog. However, there may be locations where it is desirable to supplement an existing low-point inlet with the use of a slotted drain. Slotted inlets in sag locations perform as weirs to approximate depths of 0.2 ft, dependent on slot width and length. At depths greater than 0.4 ft, they perform as orifices. Between these depths, flow is in a transition stage.

The interception capacity of a slotted inlet operating as an orifice can be computed by the following equation:

$$Q_i = 0.8LW (2gd)^{0.5} \quad (6.19)$$

Where:

L =	Length of slot, ft
W =	Width of slot, ft
g =	32.2 ft/s ²
d =	Depth of water at slot, ft

For a slot width of 1¾ in, Equation 6.19 becomes

$$Q_i = 0.94Ld^{0.5} \quad (6.20)$$

The interception capacity of slotted inlets at depths between 0.2 ft and 0.4 ft can be computed by use of the orifice equation. The orifice coefficient varies with depth, slot width and the length of slotted inlet.

For depths that are transitional between weir and orifice flow, refer to HEC 22 [\(6-4\)](#) for further information.

Flow Over Grates

There are three types of flow to consider when evaluating the interception capacity of a grate inlet. They are frontal flow, side flow, and splash-over.

- Frontal flow is the portion of the flow that passes over the upstream side of the grate.
- Side flow is the portion of flow that passes along the side of the grate.
- Splash-over is the portion of frontal flow that skips or splashes over the grate and is not intercepted.

Capacity and Interception of Grate Inlets on Grade

The interception capacity of a grate inlet is dependent upon the following parameters:

- shape or geometry
- cross slope
- longitudinal slope
- total flow
- depth of flow
- pavement roughness

The depth of water next to the curb is the major factor in the interception capacity of grate inlets and curb-opening inlets. At low velocities, all of the frontal flow is intercepted by grate inlets and a small portion of the side flow is intercepted. Splash-over tends to increase on steep longitudinal slopes.

While the parallel bar grates are the most efficient grates on steep slopes, they are not bicycle safe. The grates tested in a FHWA research study are described in HEC 22. [\(6-4\)](#)

Chart 6.1 can be used to determine splash-over velocities for various grate configurations and the portion of frontal flow intercepted by the grate.

Chart 6.1 - Source: HEC 22 (6-4)

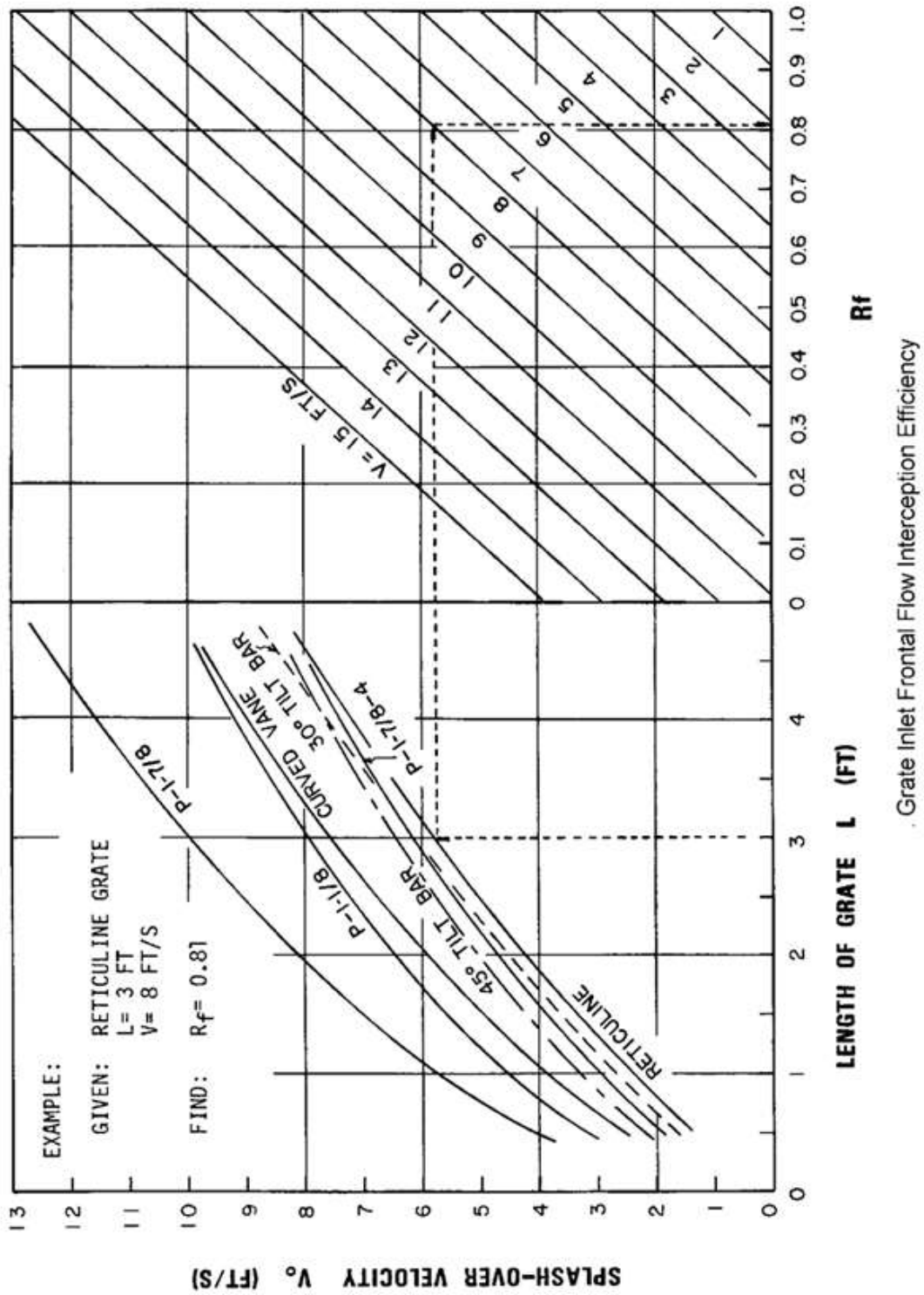

The ratio of frontal flow to total flow, E_o , for a straight cross slope is given by the following equation:

$$E_o = Q_w/Q = 1 - (1 - W/T)^{2.67} \quad (6.21)$$

Where:

- Q = Frontal flow in width W, ft³/s
- Q = Total flow, ft³/s
- W = Width of depressed gutter or grate, ft
- T = Total spread of water on pavement, ft

The ratio of side flow, Q_s , to total flow is

$$Q_s/Q = 1 - E_o \quad (6.22)$$

The ratio of frontal flow intercepted to total frontal flow, R_f , is expressed by the following equation:

$$R_f = 1 - 0.09 (V - V_o) \quad (6.23)$$

Where:

- V = Velocity of flow in the gutter, ft/s
- V = Gutter velocity where splash-over first occurs, ft/s

Note that R_f may never exceed 1.

This ratio is equivalent to frontal-flow interception efficiency. Chart 6.1 provides the splash-over velocity as well as a solution of Equation 6.23 that incorporates grate length, bar configuration and gutter velocity at which splash-over occurs. The gutter velocity needed is total gutter volumetric flow divided by the cross-sectional area of flow.

The ratio of side flow intercepted to total side flow, R_s , or side-flow interception efficiency, is expressed by the following:

$$R_s = 1 / [1 + (0.15V^{1.8}/S \times L^{2.3})] \quad (6.24)$$

Where:

- V = Velocity of flow in the gutter, ft/s
- S = Cross slope, ft/ft
- L = Length of the grate, ft

The efficiency, E, of a grate is expressed as

$$E = R_f E_o + R_s (1 - E_o) \quad (6.25)$$

Chart 6.2 provides a graphical solution to Equation 6.24.

Chart 6.2 - Source: HEC 22 (6-4)

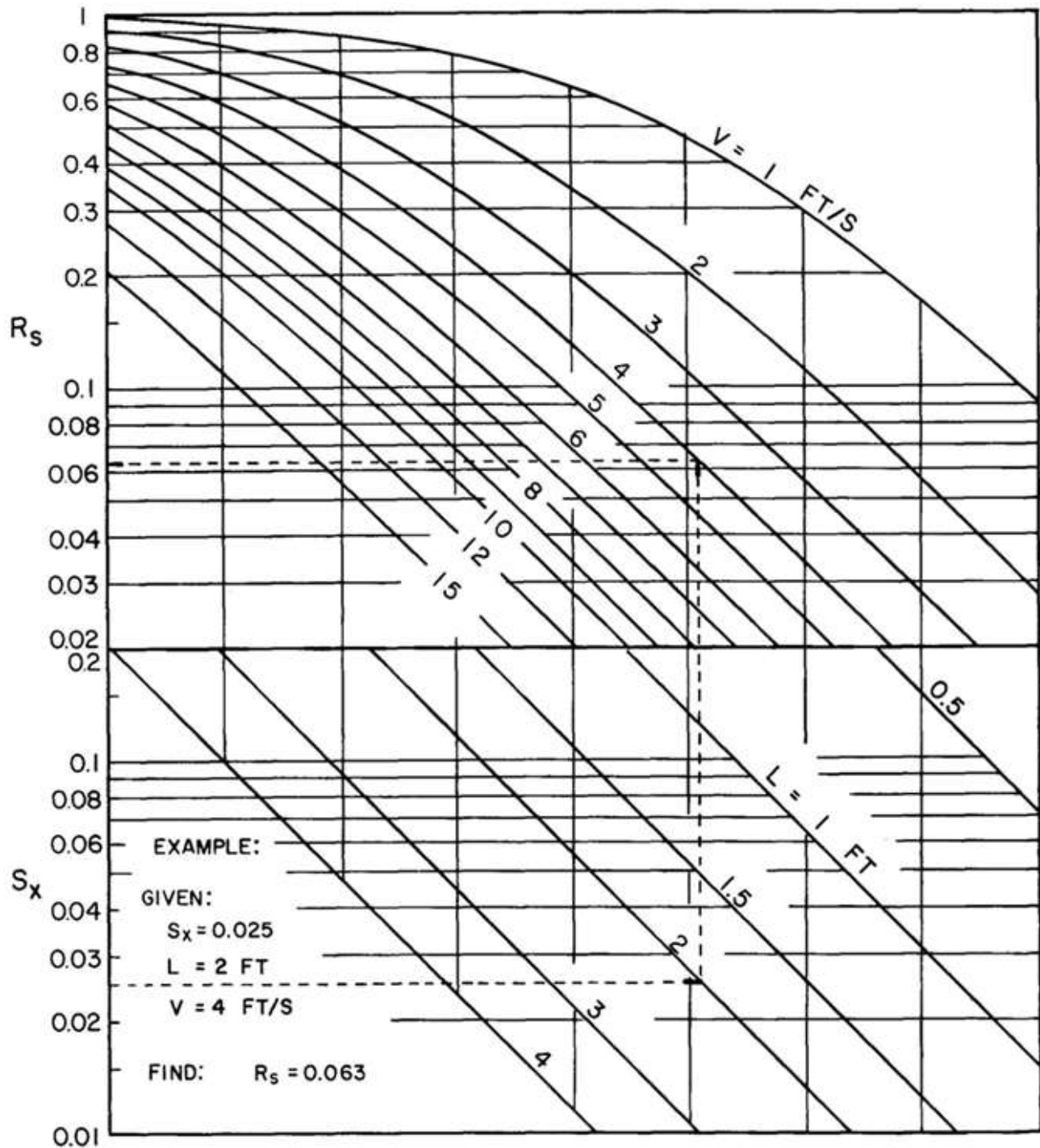

Grate Inlet Side Flow Intercept Efficiency

Capacity of Grate Inlets in Sag

Although curb-opening inlets are generally preferred to grate inlets at sag locations, grate inlets without a curb opening can be used successfully at minor sag points where debris potential is limited. An example of a minor sag point might be on a side road as it joins a mainline.

For major sag points, such as on divided highways, a curb-opening inlet or combination inlet is preferable to a grate inlet because of its hydraulic capacity and debris-handling capabilities. When grates are used, it is good engineering practice to assume half the flow intake area is clogged for gutter spread design purposes.

At low points where significant ponding can occur, such as at underpasses and in sag vertical curves, it is good engineering practice to place at least one flanking inlet on each upstream side of the sag inlet. Flanking inlets should be placed on low-gradient approaches to the low point to limit spread within the tolerances given in Table 6.3. It should be assumed that the sag inlet is completely clogged when designing flanking inlets for placement and gutter spread control.

A grate inlet in a sag operates as a weir up to a depth of about 0.4 ft and as an orifice for depths greater than 1.4 ft. Between these depths, a transition from weir to orifice flow occurs. The capacity of a grate inlet operating as a weir is:

$$Q_i = CPd^{1.5} \quad (6.26)$$

Where:

C = 3.0 weir coefficient

P = Perimeter of grate excluding bar widths and side against curb, ft

d = Average flow depth across the grate, ft, see Figure 6.11

Figure 6.11 - Average flow depth for grate inlet

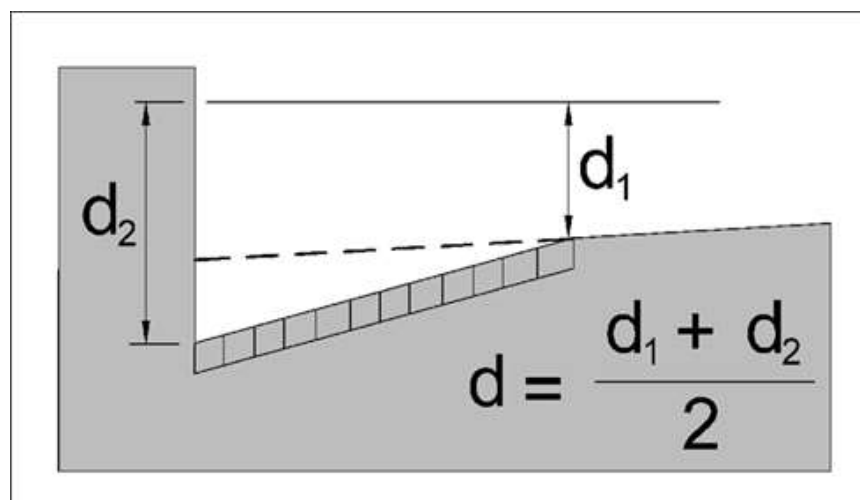

The capacity of a grate inlet operating as an orifice is:

$$Q_i = CA(2gd)^{0.5} \quad (6.27)$$

Where:

$C = 0.67$, orifice coefficient

$A =$ Clear opening area of the grate, ft

$g = 32.2 \text{ ft/s}^2$

$d =$ Average flow depth across the grate, ft, see Figure 6.11

Chart 6.3 is a plot of Equations 6.26 and 6.27 for various grate sizes. The effect of grate size on the depth at which a grate operates as an orifice is apparent from the chart. Transition from weir to orifice flow results in interception capacity less than that computed by either the weir or the orifice equation. Drawing in a curve between the lines representing the perimeter and net area of the grate to be used can approximate this capacity.

Chart 6.3 - Source: HEC 22 (6-4)

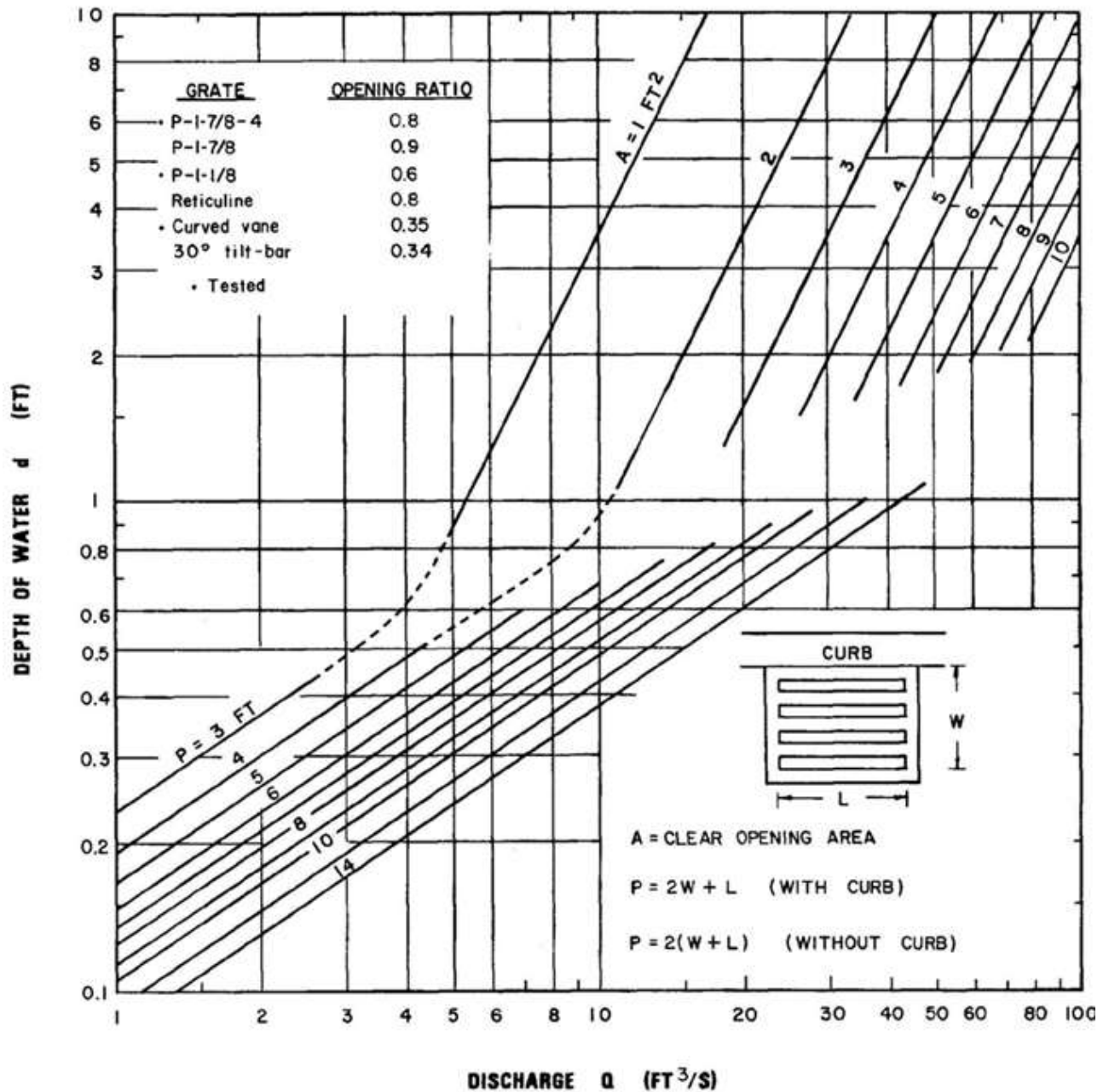

Grate Inlet Capacity in Sump Conditions - English Units

Note: Dashed lines are example representations of the curve that can be drawn between the perimeter and net area of a given grate. Drawing this type of curve allows approximation of the capacity of the grate through the transition from weir to orifice flow.

6.6 Design Procedures

The following is a summary of the design procedures for pavement drainage design:

- 6.6.1 Collect and analyze existing data
- 6.6.2 Preliminary layout - placement of drainage inlet structures due to geometric controls
- 6.6.3 Determine drainage areas and "Q's"
- 6.6.4 Placement of inlets on continuous grades
- 6.6.5 Low point and flanking structures

6.6.1 Collect and Analyze Existing Data

The following information is required for design:

- Existing natural points of concentration and discharge
- Existing drainage systems
- Existing topographic features (contour quad maps)
- Preliminary proposed plans, profiles, cross sections, superelevation
- Determination of runoff (see chapter 4)
- Existing pipe data from the Survey Data Engineer (SDE), local authorities, district maintenance office, or other similar source

Use the above collected data to make the following assessments and determinations:

- Determine natural flow patterns of the natural points of concentration and discharge.
- Locate existing features, structures, pipes, top elevations, invert elevations, pipe sizes, etc.
- Assess condition and type of existing pipes and structures to determine if any deficiencies exist.

Tip: Plotting features on a roll plot will give a better overview than separate plan sheets.

6.6.2 Preliminary Layout - Placement of Inlets Due to Geometric Controls

Drainage structure locations should be marked on the plans prior to any computations regarding discharge, water spread, inlet capacity, or flow bypass.

Inlets are required whenever the spread on the pavement reaches the limiting design criteria. There are a number of locations where inlets may be necessary with little regard to the contributing drainage area. The following list provides guidance for required placement of drainage structures on roadway projects:

- Inlets are to be placed at all sag locations and low points in the gutter grade.
- Inlets are to be placed on continuous grades to control gutter spread per Table 6.3 in section 6.2.2.
- Inlets are to be placed in locations to minimize sheet flow across the roadway

- Grate inlets with or without a hood are to be placed within turning radii. Curb-opening inlets are not to be used in radii. Metal hoods are recommended in radii to prevent crushing of the inlet top.
- Inlets should not be placed within crosswalk locations.
- Inlets are to be placed immediately upstream of median breaks, entrance/exit ramp gores, crosswalks, and street intersections (i.e., at any location where water could flow onto the travelway).
- Inlets are to be placed immediately upstream of bridges to prevent pavement drainage from flowing onto bridge decks.
- Inlets are to be placed immediately downstream of bridges to intercept bridge deck drainage even where deck drain systems exist.
- Inlets are to be placed within approximately 50 ft upgrade of flat cross slopes in superelevation transition areas.
- Inlets are to be placed immediately upgrade of pedestrian crosswalks.
- Inlets are to be placed on side streets immediately upgrade from intersections.
- Inlets are to be placed in low areas behind curbs, shoulders or sidewalks.
- Inlets are to be placed in pocketed low points. Pocketed low points commonly occur on driveways where runoff that drained to the roadway prior to construction now drains away from the roadway to the driveway.
- Use manholes rather than junction boxes when outside the roadway travel lanes and when site-specific obstacles don't exist in order to provide access.
- Special drainage systems such as trench and slotted drains should be considered and utilized as necessary to control gutter spread within tolerable limits.
- Roadside channels or inlets should be used to intercept runoff from areas draining toward a highway. This applies to drainage from cut slopes, side streets, and other areas adjacent to and draining toward the mainline pavement.

Tip: Whenever possible, low points and high points should coincide with the PI of the horizontal curve. This significantly reduces drainage problems associated with flat cross slopes in superelevation transition areas. Never locate a low point or a high point near the following locations:

- a flat cross slope in superelevation transition areas
- intersections
- sags in cut areas
- sags on bridges

6.6.3 Determine Drainage Areas and "Q's"

The Rational Method (see chapter 4 of this manual) is typically used for inlet design. Selection of design frequency (storm year) should be obtained from the policy in section 6.2.2.

6.6.4 Placement of Inlets on Continuous Grades

Placement and spacing of inlets on continuous roadway grades is dependent upon the gutter spread. It is a function of the amount of upstream bypass flow, the tributary drainage area, and the gutter geometry. Maximum allowable gutter spread widths are defined in Table 6.3 in section 6.2.2.

Selection of inlet locations on continuous grade may be done using a HEC 22 based computer program or by using a hand tabulation method similar to the one shown in Figure 6.12.

Whatever calculation method is chosen, it should be thoroughly documented so the calculations may be easily followed and reproduced by a reviewer.

6.6.5 Low Point and Flanking Structures

At sag points where stormwater cannot escape the roadway and becomes confined behind curbing with no outlet, it is recommended practice to place a minimum of one flanking inlet on each upstream side of the inlet at the sag point. The purpose of the flanking inlet is to provide a low point relief if the inlet should become completely clogged such that the allowable gutter spread is not exceeded. Where stormwater has the potential to escape the curb, the shoulder slope should be flattened or even reversed at the sag to provide an outlet.

Figure 6.12 - Sample continuous inlet spacing computation sheet

Inlet Identification Data		Storm Data			Pervious DRNG Area 1			Pervious DRNG Area 2			Impervious DRNG Area			Pavement Spread and Inlet Interception Data										
		(GDOT) Inlet Type	Time of Conc t_c (min)	Rainfall Intensity I (in/hr)	Perv DRNG Area A (acres)	Runoff Coeff C	$Q = CIA$ (cfs)	Perv DRNG Area A (acres)	Runoff Coeff C	$Q = CIA$ (cfs)	Imperv DRNG Area A (acres)	Runoff Coeff C	$Q = CIA$ (cfs)	Total Flow Q_t (cfs)	Long Slope S_L (ft/ft)	Cross Slope S_x (ft/ft)	Previous Bypass Flow (cfs)	Total Pwmt Flow (cfs)	Pwmt Spread Actual T (ft)	% Intercept	Q Intercept (cfs)	Q Bypass (cfs)		
STR #	STATION	OFFSET (ft)	(4)	(5)	(6)	(7)	(8)	(9)	(10)	(11)	(12)	(13)	(14)	(15)	(16)	(17)	(18)	(19)	(20)	(21)	(22)	(23)	(24)	

Figure 6.13 - Example of typical placement of flanking inlets (plan view)

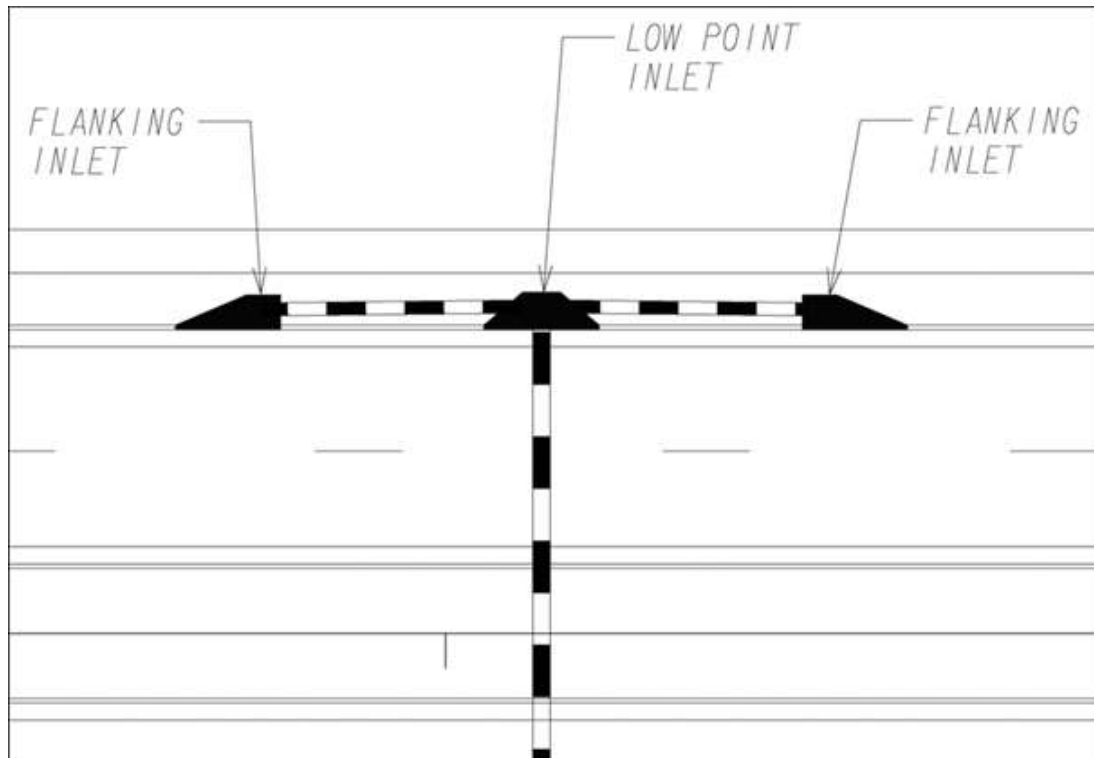

Flanking Structure Location

The flanking inlets should be placed to act in relief of the sag inlet if it should become completely clogged. The flanking inlets are to be located so that they will receive all the flow when the primary inlet at the bottom of the sag is clogged. They should do this without exceeding the allowable spread at the bottom of the sag. The following procedure demonstrates the distance to locate flanking structures using depth criteria.

If the flanking inlets are the same dimension as the primary inlet, they will each intercept one-half the design flow when they are located so that the depth of ponding at the flanking inlets is 63% of the depth of ponding at the low point. This is depicted in profile in Figure 6.14. If the flanking inlets are not the same size as the primary inlet, it will be necessary to either develop a new factor or do a trial and error solution using assumed depths with the weir equation to determine the capacity of the flanking inlet at the given depths.

The inlet spacing required for various depths at curb criteria and vertical curve lengths is defined as follows:

$$K = L / (G_2 - G_1) \quad (6.28)$$

Where:

L = Length of the vertical curve in feet

G₁, G₂ = Approach grades in percent

The AASHTO Policy on Geometric Design of Highways and Streets recommends a maximum K value of 167 feet per percent change in grade in order to facilitate drainage to inlets located at sag points and away from the level point on crest vertical curves. [\(6-1\)](#)

The distance from the bottom of the sag to the flanking inlet is:

$$X = (74 d K)^{0.5} \quad (6.29)$$

Where:

X = Maximum distance from bottom of sag to flanking inlet, ft

d = Depth of water over inlet in bottom of sag as shown in Figure 6.14, ft

K = Rate of vertical curvature as defined in Equation 6.28

Figure 6.14 - Flanking inlet schematic

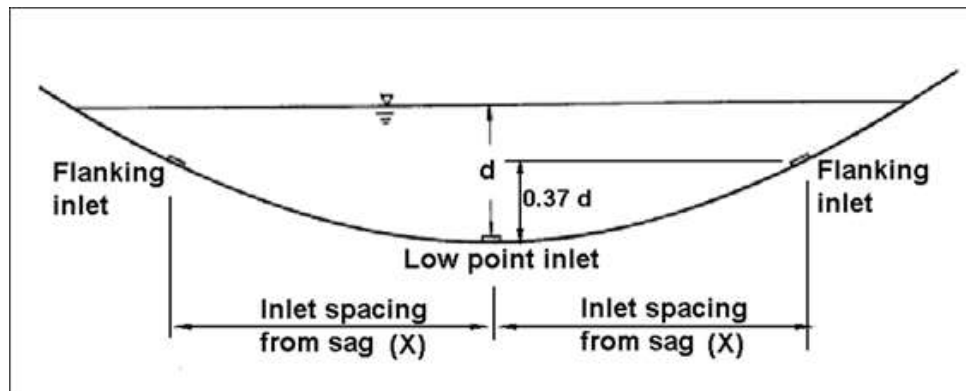

Step 1. Determine the K value for the sag curve.

Step 2. Determine the depth at design spread, $d = S_x T$ (S_x = cross slope, T = gutter spread)

Step 3. Establish X from Equation 6.29. This distance is the maximum distance that can be used.

Chapter 6 References

1. American Association of State Highway and Transportation Officials (AASHTO). 2011. Geometric Design of Highways and Streets
2. American Association of State Highway and Transportation Officials (AASHTO). 2007. Highway Drainage Guidelines, 4th Ed.
3. American Association of State Highway and Transportation Officials (AASHTO). 2005. Model Drainage Manual, 3rd Ed.
4. Brown, S.A., Schall, J.D., Morris, J.L., Doherty, C.L., Stein, S.M., Warner, J.C. 2009, Urban Drainage Design Manual, [Hydraulic Engineering Circular No. 22](#), FHWA-NHI-10-009. Federal Highway Administration (FHWA), U.S. Department of Transportation, Washington, D.C.
5. Georgia Department of Transportation (GDOT). 2013. [Design Policy Manual](#)
6. Georgia Department of Transportation (GDOT). 2012. [Plan Presentation Guide](#), Version 01.50.
7. Young, G.K, Walker, S.E., Chang, F. 1993, Design of Bridge Deck Drainage, [Hydraulic Engineering Circular No. 21](#), FHWA-SA-92-010. Federal Highway Administration (FHWA), U.S. Department of Transportation, Washington, D.C.

Intentionally Left Blank

Chapter 7. Storm Drain Design - Contents

Chapter 7.	Storm Drain Design - Contents	7-i
7.1	Introduction.....	7-1
7.1.1	Definition	7-1
7.2	Design Guidelines	7-1
7.2.1	Design Storm Frequency.....	7-2
7.2.2	Maximum Structure Spacing	7-3
7.2.3	Conduit Criteria	7-3
7.2.3.1	Minimum Pipe Size and Material.....	7-3
7.2.3.2	Minimum Cover/Clearances.....	7-6
7.2.3.3	Minimum/Maximum Velocity	7-6
7.2.4	Data Collection and Preliminary Sketch	7-6
7.2.5	Cooperative Storm Drainage Projects.....	7-7
7.2.6	Outlet Concerns	7-7
7.2.7	Access Holes.....	7-8
7.2.8	Curved Alignment.....	7-8
7.3	Hydraulics of Storm Drain Systems.....	7-9
7.3.1	Sizing of Storm Drain	7-9
7.3.1.1	Full Flow.....	7-9
7.3.1.2	Part-Full Flow	7-10
7.3.2	Minimum Grades	7-11
7.3.3	Elliptical Concrete and Metal Pipes.....	7-12
7.4	Design Procedures	7-13
7.4.1	Energy Loss Estimation for Preliminary Layout.....	7-13
7.4.2	Preliminary Layout.....	7-14
7.5	Energy Grade Line / Hydraulic Grade Line.....	7-18
7.5.1	Evaluating Tailwater	7-18
7.5.2	Energy Losses.....	7-19
7.5.2.1	Exit Loss.....	7-19
7.5.2.2	Pipe Friction Loss.....	7-19
7.5.2.3	Bend Loss	7-20
7.5.2.4	Junction Loss	7-21
7.5.2.5	Access Hole and Inlet Losses	7-21
7.5.2.6	Relative Access Hole Size	7-23
7.5.2.7	Pipe Diameter	7-23

7.5.2.8 Flow Depth7-24

7.5.2.9 Relative Flow.....7-24

7.5.2.10 Plunging Flow.....7-25

7.5.2.11 Benching7-26

7.5.2.12 Energy Losses7-27

7.6 Energy Grade Line Evaluation Procedure7-27

7.7 Computer Programs7-35

7.8 Additional Guidance7-35

7.9 Represent Drainage Design on the Plans7-36

Chapter 7 References.....7-37

Chapter 7. Storm Drain Design

7.1 Introduction

The design of a drainage system should address the needs of the traveling public as well as those of the local community through which it passes. The drainage system for a roadway traversing an urbanized region can be more complex. This can be attributed to areas with a heavy concentration of development and associated conflicts with existing utilities and the drainage system.

This chapter provides guidance on storm drain design and analysis based on procedures presented in the American Association of State Highway and Transportation Officials (AASHTO) publication, *Model Drainage Manual (MDM)* (7-1) and the FHWA publication, *Urban Drainage Design Manual* (HEC 22). (7-3) Prior to starting a storm drain design, the designer should already have a basic understanding of the hydraulic behavior of closed conduits and open channels, and the concepts related to their hydraulic performance. In addition to storm sewer design guidance, this chapter also includes discussions, factors related to, and evaluation of the hydraulic grade line (HGL) and energy grade line (EGL)

The designer should consult other chapters of this manual as appropriate for additional information relating to storm sewer design principles.

Chapter 4 – Hydrology & Hydraulics

Chapter 5 – Channels

Chapter 6 – Pavement Drainage

Chapter 8 – Culverts

7.1.1 Definition

A storm drain is the portion of the highway drainage system that receives surface water through inlets and conveys the water through conduits to a pipe outlet. It is composed of different lengths and sizes of pipe or conduit connected by structures. A section of conduit connecting one inlet or structure to another is termed a "segment" or "run." The storm drain is usually a circular pipe, but can also be a box or other enclosed conduit shape. Structures include inlet structures (excluding the actual inlet opening), access holes, junction chambers, and other miscellaneous structures. (7-3) The designer should refer to chapter 6 for more information on drainage structures used in pavement design.

7.2 Design Guidelines

The guidelines listed below are to be followed unless GDOT provides other guidance. In general, the placement and hydraulic capacity of a storm drainage facility should be designed to consider:

- Damage to adjacent property
- Traffic interruption due to flooding.
- Traffic service requirements
- Existing utilities

- Minimization of erosion at outlets
- Proposed staging of large construction projects to maintain an outlet throughout the construction project

7.2.1 Design Storm Frequency

The guidelines listed below are to be followed unless GDOT provides other guidance. In general, the storm drainage components listed below should consider the following design storm frequencies:

Longitudinal pipes for storm drains shall be designed to accommodate the 10-year frequency storm.

Storm drain systems shall be designed to accommodate the 50-year storm in areas where the flow has no outlet except through the storm drain system. The design should accommodate the 50-year storm when failure of the drainage system could result in flooding or inundation of the roadway in areas such as low points in cuts or

Table 7.1 — Storm Sewer Design Storm Event	
Facility	Design Storm Event (longitudinal)
Interstates & State Routes	⁽²⁾⁽³⁾ 10-year
Non-State Route Roadways:	
ADT = 0-99	10-year
ADT = 100-399	10-year
ADT = 400-1,499	⁽²⁾ 10-year
ADT = 1,500 +	⁽²⁾ 10-year
Temp. Detours	10-year
Permanent Bridges	50-year
Temp. Bridges:	
Local Road w/ ADT<400	10-year
All Other Roads	10-year
Note 1: All storm events listed in this table are for 24-hour duration storm events. Note 2: Longitudinal pipes for storm drains shall be designed for the 50-year design storm where the flow has no outlet except through the storm drain system. Note 3: Hydraulic Grade Line should be below finished grade for 50-year event. ADT: Average Daily Traffic	

depressed roadways. If the flow can overtop the curb and escape overland, the 50-year design criterion is not required.

A 100-year event shall be used to assess the effects of a larger runoff event on the storm drain system. Refer to chapter 6 for additional guidance regarding the 100-year design criteria.

7.2.2 Maximum Structure Spacing

Drainage structures shall be spaced to facilitate regular maintenance. Adequate access is required for inspection and cleanout of storm drain systems. The following distances are the maximum allowable spacing intervals between access points within a closed storm drain system:

Table 7.2—Maximum Structure Spacing	
Pipe Size	Maximum Spacing Interval
≤ 36 in.	400 ft
> 36 in.	600 ft
Note: See Section 5.4.1 for maximum median drop inlet spacing.	

7.2.3 Conduit Criteria

7.2.3.1 Minimum Pipe Size and Material

The guidelines listed below are to be followed unless GDOT provides other guidance. In general, pipe sizes and materials should adhere to the following guidelines:

The minimum pipe size shall be 18 inches. Specific projects may dictate a minimum pipe size larger than 18 inches to account for sediment accumulation and clogging, such as in flat terrain.

Storm sewer pipe material selection for all classifications of a roadway is based on the site specific geotechnical, environmental, and regional conditions. For pipe material selection, refer to the specific GDOT geotechnical report for the project or the approved material selections list, also provided in Table 7.3, from the GDOT Geotechnical Manual. The following webpage should be accessed to obtain the most current GDOT approved material selection list:

<http://www.dot.ga.gov/PS/Materials>.

Table 7.3—Selection Guideline for Culvert, Slope, and Underdrain Pipe

PIPE TYPE	INSTALLATION TYPE														
	STORM DRAIN								NON-TRAVEL BEARING (Outside Roadbed)			SIDE DRAIN	PERMANENT SLOPE DRAIN	PERFORATED UNDERDRAIN	
	TRAVEL BEARING (Inside Roadbed)				Grade > 10%	Interstate	Non-Interstate								
	GRADE ≤ 10%														
Concrete Pipes Section 843 Reinforced Concrete AASHTO M 170	ADT < 1500	ADT ≥ 1500 < 5000	ADT ≥ 5000 < 15,000	ADT ≥ 15,000 & Interstates	Grade > 10%	Interstate	Non-Interstate	Interstate	Non-Interstate	Interstate	Non-Interstate	Side Drain	Perman. Slope Drain	Perforated Underdrain	
	YES	YES	YES	YES	NO	YES	YES	YES	YES	YES	YES	YES	NO	NO	
	See Table 1 below for Site Condition Restrictions														
Steel Pipes Section 884 Corrugated Steel Aluminum Coated (Type 2) AASHTO M 36 Corrugated Steel Plain Zinc Coated AASHTO M 36 Polymer Coated Steel AASHTO M 245	YES	YES	NO	NO	NO	NO	NO	NO	NO	NO	NO	YES	YES	YES	
	NO	NO	NO	NO	NO	NO	NO	NO	NO	NO	NO	YES	YES	YES	
	YES	YES	NO	NO	YES	NO	YES	YES	NO	NO	NO	YES	YES	NO	
Aluminum Alloy Pipes Section 840 Corrugated Aluminum AASHTO M 196 Thermoplastic Pipes Section 845 Corrugated HDPE AASHTO M 252 Corrugated Smooth Lined HDPE AASHTO M 294 Type "S" Corrugated Smooth Lined Polypropylene AASHTO M 330 PVC Corrugated Smooth Interior ASTM F 949 PVC Profile Wall AASHTO M 301.4	See Table 1 below for Site Condition Restrictions														
	YES	YES	NO	NO	NO	NO	NO	NO	NO	NO	NO	NO	YES	YES	YES
	NO	NO	NO	NO	NO	NO	NO	NO	NO	NO	NO	NO	NO	NO	NO
YES	YES	YES	YES	YES	YES	YES	YES	YES	YES	YES	YES	YES	YES	YES	

**Table 1
Site Condition Restrictions for Metal Pipe**

Pipe Type	Allowable pH Range (Soil or Water)		Allowable Resistivity Range (Ohms-cm)
	Minimum	Maximum	
Steel Pipes Section 844			Minimum
Corrugated Steel Aluminum Coated (Type 2) AASHTO M 36	4.5	5.0	5,000
	5.0	9.0	1,500
Corrugated Steel Plain Zinc Coated AASHTO M 36	6.0	10.5	8,000
Polymer Coated Steel AASHTO M 245	4.0	9.0	750
Aluminum Alloy Pipes Section 840			
Corrugated Aluminum AASHTO M 196	4.5	9.0	1,500

Note: If environmental conditions fall outside the specified requirements listed above, the Office of Materials and Testing will make recommendations concerning allowable high performance corrosion protection systems.

- Structural, installation, fill height and backfill requirements of storm drain pipe will be in accordance with Georgia Standard 1030-D or 1030-P and the Standard Specifications.
- Procedure for designating pipe culvert materials according to the Standard Specifications:
 - Regardless of funding on all projects where a soil survey is not made, the Office of Materials and Testing will furnish, upon request, a recommendation of allowable materials.
 - The Summary, Detailed Estimate, and Proposal will include the item in accordance with Georgia Standard 1030-D or 1030-P using a non-specifying nomenclature.
 - Allowable pipe materials for the project will be noted on the Plan Summary Sheet.
 - Other acceptable pipe materials and/or high performance corrosion protection systems will be noted on the Plan Summary Sheet.
 - If steel structural plate for pipe, pipe arches, and arches are required on a project, the materials and coating requirements will be noted on the Plan Summary Sheet.

Definitions:
 Roadbed – The graded portion of a highway within top and side slopes, prepared as a foundation for the pavement structure and shoulder. (Section 101.51)
 Side Drain – All driveway pipes (commercial, non-commercial, residential, utility, farm, logging, and mining.)

7.2.3.2 Minimum Cover/Clearances

The minimum allowable depth of cover for all conduits under design loads (pipes, boxes, etc.) should be 12 inches, measured from the bottom of the subgrade to the outside surface of the pipe.

The minimum clearance between underground utilities and the exterior surface of storm sewer conduits should be 6 inches.

Minimum cover shall be maintained at all points where a pipe is beneath travel lanes or shoulders. In particular, this may become an issue when designing a pipe to connect to the catch basin at the sag point of a steep grade. The pavement grades between the sag inlet and the next upstream curb inlet will be curved. However, the pipe connecting the two inlets will be straight. Thus, if the pipe is at or near minimum depth of cover at the catch basins, the depth of cover will be less than allowable at some point near the middle of the pipe run. In extreme cases, the top of the pipe might even “daylight.” An additional catch basin placed at the point of minimum cover will usually be sufficient to correct this problem. Showing catch basins and manholes at the correct scale on the roadway profile drawings will facilitate checking of the minimum cover criteria (refer to chapter 6 for more information on structures). [\(7-5\)](#)

7.2.3.3 Minimum/Maximum Velocity

The guidelines listed below are to be followed unless GDOT provides other guidance. In general, the following minimum and maximum velocities are provided:

- Generally, storm drains should be designed to provide a velocity of at least 3 ft/s during the design storm event to aid in self-cleaning of the pipe. For most design situations, the flow velocity at the actual design discharge will be approximately equal to the velocity at full flow. Thus, the full flow velocity may be used to check this criterion. [\(7-5\)](#)
- Slopes that incur uniform flow velocities in excess of 12 ft/s during the design storm event should be avoided due to the potential for abrasion. In steeper terrain, large elevation differences can be accommodated by using drop structures. [\(7-5\)](#) The maximum velocity requirement is based on design calculations for concrete pipe. If the contractor chooses an approved alternate pipe material other than concrete, flow velocities must not exceed the manufacturer’s recommendations.

Refer to section 7.3.2 in this chapter for a more in-depth discussion of minimum grades for closed conduits.

7.2.4 Data Collection and Preliminary Sketch

The design of a storm drain system evolves as a project develops. Preliminary sketches or schematics featuring the basic components of the intended design are useful and serve as a starting point for the storm drainage design. The designer should acquire or address the following minimum necessary information:

- Project survey information, including existing utility locations (look for potential conflicts)
- Off-site drainage information, including land-use patterns and soil types
- Existing drainage information, including information on the existing storm drainage system and existing pipe outlets

- Local information, including comprehensive stormwater management plans and floodplain ordinances
- Federal and state regulatory requirements
- Flood elevations and historical high water marks
- Water quality requirements at environmentally sensitive discharge points

The following should be included in the preliminary sketch:

- Watershed areas and land use
- Existing drainage patterns
- Plan and profile of the roadway
- Roadway cross section
- Typical sections
- Street and driveway layout with respect to the project roadway
- Underground utility locations and elevations
- Locations of proposed retaining walls, bridge abutments, and piers
- Logical inlet and access hole locations
- Preliminary lateral and trunk line layouts
- Clear definition of the discharge points and characteristics

Unless the proposed system is very simple and small, the designer should develop a preliminary sketch as described above. The next step in creating a preliminary design of the storm drainage system is discussed in section 7.4.

7.2.5 Cooperative Storm Drainage Projects

Cooperative storm drain projects with cities and municipalities may be beneficial where both a mutual economic benefit and a demonstrated need exist. Early coordination with the governmental entities involved is necessary to determine the scope of the project. Each cooperative project may be initiated by a resolution adopted by the governing body of the municipality either (1) requesting the improvements and/or indicating its willingness to share the cost of a state project, or (2) indicating the municipality's intention to make certain improvements and requesting state cost participation in the municipal project.

7.2.6 Outlet Concerns

In the design of a storm drain system, establish the location of the pipe outlets. The outlets become one of the control points that will influence the grade and the subsequent design of the system. Always strive for a gravity flow system. Pumping stations are to be avoided except in extreme circumstances and never proposed without consultation with GDOT.

Since highway systems may increase peak discharge and volume due to increases in the impervious area and decreases in the time of concentration or lag time, accumulation or diversion

of flow may also result in an increase in runoff at storm drain outlets. The channel stability of the discharge channels/storm drain systems must be assessed, especially when there are significant changes in discharges due to highway projects or developments.

The orientation of the pipe outlet is another important design consideration. Where practical, the outlet of the storm drain should be positioned in the outlet channel so that it is pointed in a downstream direction. This will reduce turbulence and the potential for excessive erosion. If the pipe outlet structure cannot be oriented in a downstream direction, the potential for outlet scour must be considered. For example, where a storm drain outlet discharges perpendicular to the direction of flow of the receiving channel, care must be taken to avoid erosion on the opposite channel bank. If erosion potential exists, a channel bank lining of riprap or other suitable material should be installed on the bank (see chapter 9). Alternatively, an energy dissipating structure could be used at the storm drain outlet (See chapter 11). Either method of stream bank stabilization may require coordination with the United States Army Corps of Engineers (USACE) for additional permitting. See chapter 2 for agency coordination information.

Detention basins may be used to reduce flooding caused by the increased runoff if there is enough right-of-way (ROW) to accommodate a basin facility (see chapter 9).

7.2.7 Access Holes

Access holes are used to provide entry to continuous underground storm drains for inspection and cleanout. When entry into the system can be provided by a grate inlet, some agencies opt to use these in lieu of access holes. The use of grate inlets provides the benefit of achieving extra stormwater interception with minimal additional cost. The following are some typical locations where access holes should be specified:

- Where two or more storm drains converge
- At intermediate points along tangent sections
- Where pipe size changes
- Where an abrupt change in alignment occurs
- Where an abrupt change of the grade occurs

Access holes should not be located in traffic lanes. The spacing of access holes should be in accordance with section 7.2.2.

7.2.8 Curved Alignment

Curved storm drains are permitted where necessary. Long-radius bend sections are available from many suppliers and are a more preferable means of changing direction in pipes 48 inches and larger. Short-radius bend sections are also available and can be used if there is not enough room to accommodate a long-radius bend within a storm conveyance system. Deflecting the joints to obtain the necessary curvature is not desirable except in very minor curvatures. Using large access holes solely for changing direction may not be cost effective on large-size storm drains.

7.3 Hydraulics of Storm Drain Systems

Hydraulic design of storm drainage systems requires an understanding of basic hydrologic and hydraulic concepts. Important hydraulic principles include flow classification, conservation of mass, conservation of momentum, and conservation of energy.

The desired flow regime for the design of a drain system should be open channel flow. Pressure flow, or the surcharging of drain systems, is not as desirable, but can be accommodated if adequate separation is provided within the storm structure(s) to withstand pressurized flow. A check of the HGL should also be included to evaluate the containment of the HGL within the drain system as well as energy losses for the desired design storm and larger storm events. The HGL check is needed to verify that the pressure flow (or surge) within the drain system for larger storm events is controlled and released at outlet points where flooding can be minimized. A factor of safety is often desired where headroom within the drain system is needed for pressure flow as supported from the HGL check.

The designer should consult chapter 4 for a general discussion of the above mentioned hydraulic principles; the following sections assume a basic understanding of these topics.

7.3.1 Sizing of Storm Drain

7.3.1.1 Full Flow

The hydraulic capacity of a storm drain is controlled by its size, shape, slope, and friction resistance. Several flow friction formulas define the relationship between flow capacity and these parameters. The most widely used formula for gravity and pressure flow in storm drains is Manning's equation. The Manning's equation was introduced in chapter 4 and further explained in chapter 5 for computing the flow capacity for roadside and median channels.

For any shape of conduit, Manning's equation, as introduced in the earlier chapters of this manual, should be used. However, for circular storm drains flowing full, where the hydraulic radius equals the diameter divided by 4 ($R = D/4$), Manning's equation solved for V and Q , becomes:

$$V = \frac{0.590}{n} D^{2/3} S^{1/2} \quad (7.1)$$

$$Q = \frac{0.463}{n} D^{8/3} S^{1/2} \quad (7.2)$$

Where:

- Q = Flow rate, ft³/s
- V = Mean velocity of flow, ft/s
- n = Manning's coefficient of channel roughness
- D = Diameter of pipe, ft
- S = Slope of the energy grade line, ft/ft

Equation 7.2 may be rearranged to solve for the diameter directly.

$$D = \left(\frac{Q n}{0.463 S^{0.5}} \right)^{0.375} \tag{7.3}$$

Nomographs have been developed as an alternate method to solve the Manning's equation for full flow in circular conduits. For guidelines on using nomographs, the designer should reference the FHWA publication, *Hydraulic Design of Highway Culverts* (HDS-5). [\(7-4\)](#)

Representative values of the Manning's coefficient for various storm drain materials are provided in Table 7.4. It should be remembered that the values in the table are for new pipe tested in a laboratory. Actual field values for culverts may vary depending on the effect of abrasion, corrosion, deflection, and joint conditions. In addition, a full table of Manning's coefficients is provided in [Appendix D](#).

Table 7.4—Average Manning's n values for storm sewer pipes <small>(Adapted from 7-3)</small>	
Pipe Material	n value
Reinforced Concrete (pipe, elliptical or box)	0.013
HDPE, with smooth liner	0.013
HDPE, unlined	0.024
PVC, all types	0.013
Corrugated Metal	0.024
Steel Reinforced Thermoplastic Ribbed	0.013
Spiral Rolled Corrugated Metal	0.024

7.3.1.2 Part-Full Flow

The hydraulic elements graph in Figure 7.1 is provided to assist in the solution of the Manning's equation for part-full flow in storm drains. The hydraulic elements chart shows the relative flow conditions at different depths in a circular pipe and makes the following important points:

- Peak flow occurs at 93% of the height of the pipe. This means that if the pipe is designed for full flow, the design will be slightly conservative.
- Velocity in a pipe flowing half-full is the same as the velocity for full flow.
- Flow velocities for flow depths greater than half-full are greater than velocities at full flow.
- As the depth of flow drops below half-full, the flow velocity drops off rapidly.

The shape of a storm drain conduit also influences its capacity. Although most storm drain conduits are circular, a significant increase in capacity can be realized by using an alternate shape. (7-3)

Figure 7.1 - Hydraulics elements chart

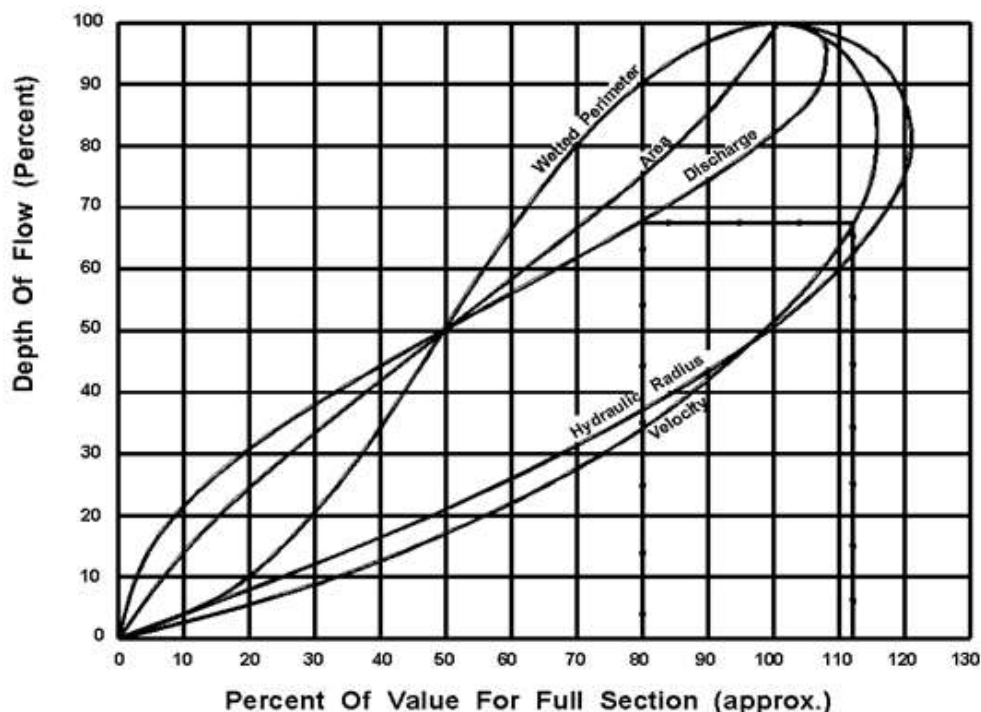

7.3.2 Minimum Grades

As stated in 7.2.3, all storm drains should be designed such that velocities of flow will not be less than 3 ft/s at the design flow. For very flat grades, the general practice is to design components so that flow velocities will increase progressively throughout the length of the pipe system. The storm drainage system should be checked to verify that there is sufficient velocity (i.e., 3 ft/s) in all drains to deter settling of particles. Minimum slopes required for a velocity of 3 ft/s can be calculated by the rearranged Manning’s equation (7.4), or obtained using Table 7.5.

$$S = 2.87 \left[\frac{nV}{D^{0.67}} \right]^2 \tag{7.4}$$

Where:

- S = Slope of the energy grade line, ft/ft
- n = Manning's coefficient of channel roughness
- V = Mean velocity of flow, ft/s
- D = Diameter of pipe, ft

Table 7.5—Minimum slopes necessary for velocity of 3 ft/s in circular pipes flowing full

Pipe Size (in)	Full Pipe (ft ³ /s)	Minimum Slopes (ft/ft)		
		n = 0.012	n = 0.013	n = 0.024
15	3.68	0.0028	0.0032	0.0111
18	5.30	0.0022	0.0026	0.0087
21	7.22	0.0018	0.0021	0.0071
24	9.43	0.0015	0.0017	0.0059
27	11.93	0.0013	0.0015	0.0051
30	14.73	0.0011	0.0013	0.0044
33	17.82	0.00097	0.0011	0.0039
36	21.21	0.00086	0.0010	0.0034
42	28.86	0.00070	0.00082	0.0028
48	37.70	0.00059	0.00069	0.0023
54	47.71	0.00050	0.00059	0.0020
60	58.90	0.00044	0.00051	0.0017
66	71.27	0.00038	0.00045	0.0015
72	84.82	0.00024	0.00040	0.0014

7.3.3 Elliptical Concrete and Metal Pipes

Elliptical and arch pipes are to follow the latest AASHTO and the American Concrete Pipe Association recommendations. See ASTM C507 (AASHTO M207) specifications. An elliptical pipe can be installed with the major axis horizontal or vertical, as shown in Figure 7.2. The orientation will affect the structural strength and hydraulic characteristics of the pipe.

Figure 7.2 - Elliptical pipe orientation [\(7-2\)](#)

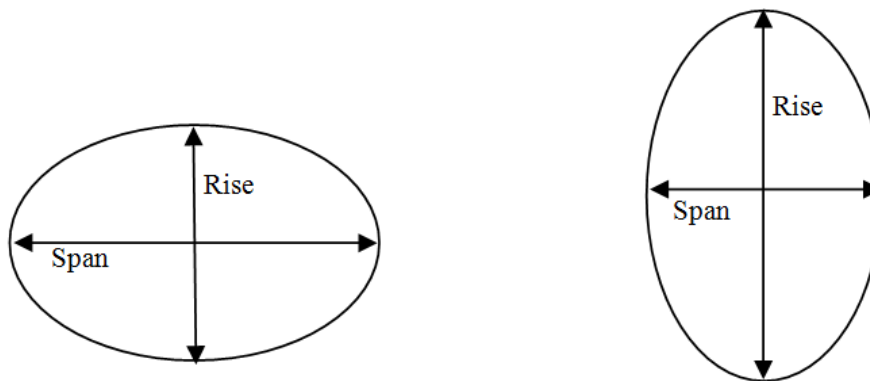

Horizontal elliptical concrete pipes are often used when there is limited vertical clearance due to existing structures or for when minimum cover is available. With the same depth of flow as most other conveyance structures with equivalent cross-sectional area, horizontal elliptical pipes provide greater flow capacity. Due to the smaller rise, there is a reduction in effective lateral support of a horizontal elliptical pipe compared to a circular pipe. In addition, its span results in greater earth loadings for the same height of cover.

Vertical elliptical concrete pipe is often used in conjunction with minimum horizontal clearances or where high strength is needed. Under minimum flow conditions, flow through a vertical elliptical pipe travels at a higher velocity, and at the same flow rate, flow depths are higher than with an equivalent horizontal elliptical or circular pipe. Because vertical elliptical pipes have a narrower span, less excavation is required for trench conditions, which results in lower vertical earth loads.

7.4 Design Procedures

This section will focus on the design procedures for a system including the calculations necessary for determining pipe sizes and the evaluation of the hydraulic grade line. The following subheadings under 7.4 Design Procedures will follow the steps required in the design progression.

7.4.1 Energy Loss Estimation for Preliminary Layout

The approximate method for computing losses at access holes or inlet structures involves multiplying the velocity head of the outflow pipe by a coefficient as represented in Equation 7.5. Applicable coefficients (K_{ah}) are tabulated in Table 7.6. This method can be used to estimate the initial pipe crown drop across an access hole or inlet structure to offset energy losses at the structure. The crown drop is then used to establish the appropriate pipe invert elevations. However, this method is used only in the preliminary design process and should not be used in the EGL calculations. For calculation of the HGL, a more detailed and precise procedure will be used (see section 7.5).

$$H_{ah} = K_{ah} \left(\frac{V_o^2}{2g} \right)$$

(7.5)

Where:

- H_{ah} = Estimated energy loss (head loss) across the structure, ft
- K_{ah} = Head loss coefficient as illustrated in Figure 7.3
- V_o = Velocity of flow leaving structure in outflow pipe, ft/s
- g = Acceleration of gravity (32.2 ft/s²)

Figure 7.3 - Interior angle

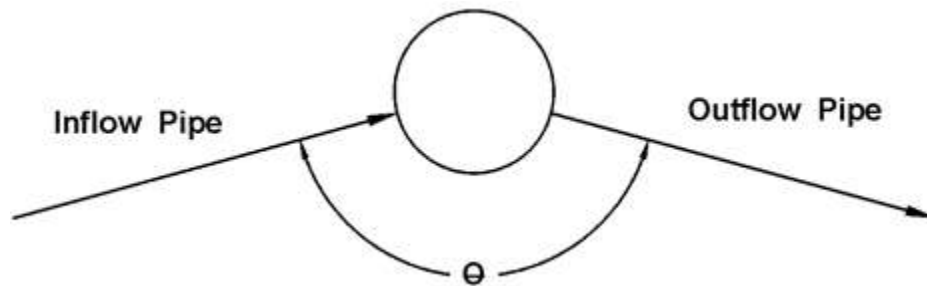

Table 7.6—Head loss coefficients ⁽⁷⁻³⁾

	K_{ah}
Inlet - straight run	0.50
Inlet - angled through	
90°	1.50
Manhole - straight run	0.15
Manhole - angled through	
90°	1.00
120°	0.85
135°	0.75
157.5°	0.45

7.4.2 Preliminary Layout

The subsequent procedure assumes that each storm drain will be initially designed to flow full under gravity conditions. The designer must recognize that when the steps in this section are complete, the design is only preliminary. Final design is accomplished after the energy grade line and hydraulic grade line computations have been completed (see section 7.5).

Discharge Computations for Pipe Sizing

At each point in the system, the drainage area, A, served by the specific inlet is determined, along with the runoff coefficient, C (runoff coefficient values can be found in chapter 4). These two values

are multiplied to determine the parameter “CA” which, is then added to the total “CA” values computed at all of the upstream inlets.

The total flow time from the beginning of the system to the point of interest is then computed. This flow time is used to determine a value of rainfall intensity from either the 10-year or the 50-year intensity-duration-frequency (IDF) curves for that location. This is multiplied by the total of the “CA” values to determine the design discharge for the site.

The preliminary design of storm drains can be accomplished by using the preliminary storm drain computation sheet provided in Figure 7.4 and the following steps:

- Step 1** Determine inlet location and spacing as outlined earlier in this chapter.
- Step 2** Prepare the plan layout of the storm drainage system establishing the following design data:
- a. Location of storm drains
 - b. Direction of flow
 - c. Location of access holes
 - d. Check crossing with existing utilities located during the preliminary sketch (e.g., water, gas, underground cables, and existing and proposed foundations)
- Step 3** For the most upstream catch basin in the system, determine the following:
- the drainage area, A_r , runoff coefficient, C_r , and time of concentration, T_{cr} , for the roadway
 - the drainage area, A_o , runoff coefficient, C_o , and time of concentration, T_{co} , for any off-site runoff to that catch basin

- Step 4** Compute “Sum CA” for the catch basin as

$$\sum CA = C_r A_r + C_o A_o$$

- Step 5** Determine the time of concentration, T_c , for the first catch basin as the longest of T_{cr} , T_{co} and 5 minutes. Determine the rainfall intensity, i , corresponding to the time of concentration from either the 10-year or the 50-year IDF curves which apply to the project site.

- Step 6** Determine the design flow rate as:

$$Q = (\sum CA)i$$

- Step 7** For each subsequent catch basin, determine the drainage area, runoff coefficient and time of concentration for the roadway, and any additional off-site areas draining to that catch basin. Compute

$$\sum CA = (\text{Upstream} \sum CA) + C_r A_r + C_o A_o$$

Where C_r , A_r , C_o , and A_o are as defined in Step 3.

Step 8 The time of concentration for the system is not necessarily equal to the inlet time. Thus, determine the time of concentration, T_c , for the catch basin as the longest of the following:

- time of concentration for roadway flows to the inlet, T_{cr}
- time of concentration for off-site flows to the inlet, T_{co}
- [Upstream T_c] + upstream pipe travel time as determined from the pipe capacity computations

Step 9 Determine the rainfall intensity, i , corresponding to the time of concentration from the IDF curve which applies to the project site.

Step 10 Determine the design flow rate

$$Q = (\sum CA)i$$

Step 11 Repeat Steps 5 through 8 for each catch basin, proceeding in the downstream direction to the system discharge point.

Step 12 Complete the design by calculating the hydraulic grade line as described in section 7.5. The design procedure should include the following:

- Storm drain design computations can be made on the computation sheet as illustrated in Figure 7.4.
- All computations and design sheets should be clearly identified. The designer's initials and date of computations should be shown on every sheet. Voided or superseded sheets should be so marked. The origin of data used on one sheet but computed on another should be provided.
- If the designer chooses to use software for assistance in storm drain design computations, the output should be formatted in such a way to match the computation sheet shown in Figure 7.4.

Figure 7.4 - Preliminary storm drain computation sheet

STR. ID		LENGTH	DRAINAGE AREA		RUNOFF COEFF. "C"	"AREA" X "C"		TIME OF CONCENTRATION	RAIN "I"	RUNOFF "Q"	PIPE DIA.	SLOPE	Q FULL	VELOCITY		SEC TIME	INVERT ELEV.		CROWN DROP	
FROM (1)	TO (2)	(3)	INC (4)	TOTAL (4)		INC (7)	TOTAL (8)	INLET (MIN) (9)	(IN/HR) (11)	(FT ³ /S) (12)	() (13)	(/) (14)	(FT ³ /S) (15)	FULL (FT ³ /S) (16)	DESIGN (FT ³ /S) (17)	(MIN) (18)	U/S () (19)	D/S () (20)	() (21)	

7.5 Energy Grade Line / Hydraulic Grade Line

The designer should reference chapter 4 for an introduction of the energy equation and for a discussion on the EGL and HGL.

Knowing the location of the EGL is critical to understanding and estimating the location of the HGL. The HGL is used to aid the designer in determining the acceptability of a proposed storm drainage system by establishing the elevation to which water will rise when the system is operating under design conditions. Refer to Figure 7.5, as well as Figures 4.4 and 4.5 in chapter 4 for the application of the energy equation in open channel flow and pressure flow.

Figure 7.5 - Hydraulic and energy grade lines in pipe flow

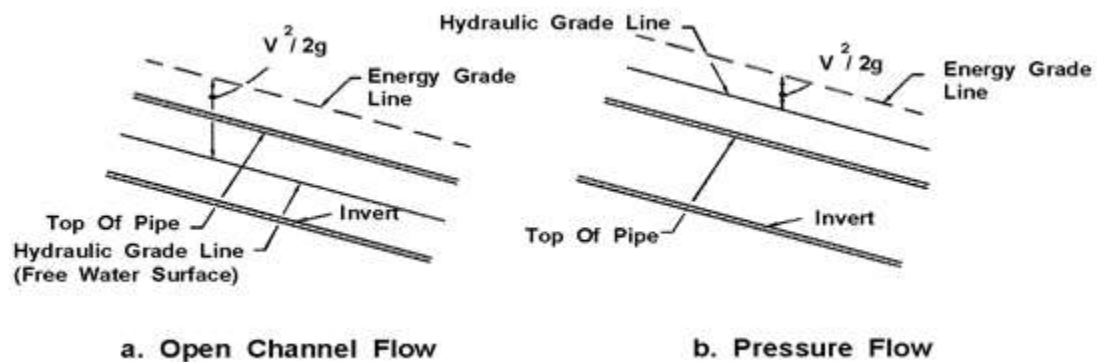

In storm drains, the HGL location varies and corresponds to one of the two flow conditions listed below:

- Open channel flow - When water is flowing through the pipe and there is a space of air between the top of the water and the inside of the pipe, the flow is considered as open channel flow and the HGL is at the water surface.
- Pressure flow - When the pipe is flowing full under pressure flow, the HGL will be above the crown of the pipe and is the level to which water would rise in a vertical tube at any point along the pipe.

Full gravity flow, a specific state of open channel flow, can be classified as the flow in the pipe just before reaching the point where the pipe is flowing full. At this condition the pipe is under gravity full flow and the flow is influenced by the resistance of the total circumference of the pipe. Under gravity full flow, the HGL is still at the water surface, which coincides with the crown of the pipe.

Inlet surcharging and possible lid displacement of access holes can occur if the hydraulic grade line rises above the ground surface. Storm drainage systems can often alternate between pressure and open channel flow conditions from one section to another. The designer should check pipe sizes and inverts to prevent this type of hydraulically surcharged condition.

7.5.1 Evaluating Tailwater

For each run of pipe the hydraulic grade line analysis must begin from a “known” tailwater elevation. For the first pipe in the closed drainage system, this elevation should be determined based on a

hydraulic analysis of the channel or other conveyance at the system discharge location. Otherwise, the tailwater elevation will have to be determined from an analysis of the downstream pipe.

At the system discharge location, the tailwater conveyance can typically be approximated assuming open channel flow with a normal depth and flow velocity, which can be calculated using Manning's equation as described in chapters 4 and 5. This will usually result in a measurable amount of velocity head. In these situations, the designer should calculate both the EGL and the HGL downstream of the pipe. Where the tailwater condition is determined by a catch basin or manhole in a surcharged condition (i.e. – the water surface is above the crown of the outlet pipe), the EGL and HGL may be assumed to be approximately equal since turbulence within the structure renders the velocity negligible and difficult to determine. However, where the depth in a structure is less than the crown of the outlet pipe, it may be necessary to determine the EGL and HGL separately since the bench in the structure can help to organize the flow. (7-5)

7.5.2 Energy Losses

Prior to computing the hydraulic grade line, all energy losses in pipe runs and junctions must be estimated. This section presents relationships for estimating typical energy losses in storm drainage systems.

7.5.2.1 Exit Loss

The exit loss is a function of the change in velocity at the outlet of the pipe. For a sudden expansion at the outlet, the exit loss is as follows:

$$H_o = C_o \left[\frac{V_o^2}{2g} - \frac{V_d^2}{2g} \right] \quad (7.6)$$

Where:

- H_o = Outlet velocity head, ft
- C_o = Exit loss coefficient (1.0)
- V_o = Average outlet velocity, ft/s
- V_d = Channel velocity downstream of outlet, ft/s

Note that, when $V_d = 0$ as in a reservoir, the exit loss is one velocity head. For partially full flow where a properly aligned pipe discharges into a channel with moving water, the exit loss may be reduced to virtually zero.

7.5.2.2 Pipe Friction Loss

The major loss in a storm drainage system is the friction or boundary shear loss. The head loss due to friction in a pipe is computed as follows

$$H_f = S_f L \quad (7.7)$$

Where:

- H_f = Friction loss, ft
 S_f = Friction slope, ft/ft
 L = Length of pipe, ft

The friction slope in Equation 7.7 is also the slope of the hydraulic gradient for a particular pipe run. Since this design procedure assumes steady uniform and open channel flow, the friction slope will match the pipe slope for part-full flow. Pipe friction losses for full flow can be determined by combining Equation 7.7 with the Manning's equation as follows:

$$S_f = \left(\frac{Q n}{1.486 A R^{2/3}} \right)^2 \quad (7.8)$$

Equation 7.8 is applied for any shape of conduit. For a circular pipe flowing full, the following equation may be developed:

$$S_f = \left(\frac{Q n}{0.463 D^{2.67}} \right)^2 \quad (7.9)$$

Combining Equations 7.7 and 7.9, the following equation may be developed:

$$H_f = 4.665 \left(\frac{Q n}{D^{2.67}} \right)^2 L \quad (7.10)$$

7.5.2.3 Bend Loss

The bend loss coefficient for storm drain design is minor, but can be evaluated using the following formula:

$$h_b = 0.0033 (\Delta)(V_o^2 / 2g) \quad (7.11)$$

Where:

- Δ = Angle of curvature, degrees
 V_o = Average outlet velocity, ft/s

A pipe junction is the connection of a lateral pipe to a larger trunk pipe without the use of an access hole. The minor loss equation for a pipe junction is a form of the momentum equation as follows:

7.5.2.4 Junction Loss

$$H_J = \frac{(Q_o V_o) - (Q_L V_L) - (Q_i V_L \cos \theta)}{0.5 g (A_o + A_i)} + h_i - h_o \quad (7.12)$$

Where:

H_J =	Junction loss, ft
Q_o, Q_i, Q_L =	Outlet, inlet, and lateral flows, respectively, ft ³ /s
V_o, v_i, V_L =	Outlet, inlet, and lateral velocities, respectively, ft/s
h_o, h_i =	Outlet and inlet velocity heads, respectively, ft
A_o, A_i =	Outlet and inlet cross-sectional areas, ft ²
q =	Angle between the inflow and outflow pipes (Figure 7.3)

As introduced in section 7.4.1, the energy loss encountered going from one pipe to another through an access hole is commonly represented as being proportional to the velocity head of the outlet pipe. Experimental studies have determined that the K value can be approximated by the relationship in Equation 7.13 when the inflow pipe invert is below the water level in the access hole.

7.5.2.5 Access Hole and Inlet Losses

$$K = K_o C_D C_d C_Q C_p C_B \quad (7.13)$$

Where:

K =	Adjusted loss coefficient
K_o =	Initial head loss coefficient based on relative access hole size
C_D =	Correction factor for pipe diameter (pressure flow only)
C_d =	Correction factor for flow depth (non-pressure flow only)
C_Q =	Correction factor for relative flow
C_p =	Correction factor for plunging flow
C_B =	Correction factor for benching

For cases where the inflow pipe invert is above the access hole water level, the outflow pipe will function as a culvert, and the access hole loss and the access hole HGL can be computed using procedures found in the FHWA publication, *Hydraulic Design of Highway Culverts* (HDS-5).⁽⁷⁻⁴⁾ If the outflow pipe is flowing full or partially full under outlet control, the access hole loss (due to flow contraction into the outflow pipe) can be computed by setting K to K_e as reported in Table 7.7. If the outflow pipe is flowing under inlet control, the water depth in the access hole should be computed using the FHWA inlet control charts that can be found in HDS-5, *Hydraulic Design of Highway Culverts* ⁽⁷⁻⁴⁾ (see Charts 7.3 and 7.4).

Table 7.7—Entrance loss coefficients. (7-4)

Type of Structure and Design of Entrance	Coefficient K_e
Pipe, Concrete	
Projecting from fill, socket end (groove-end)	0.2
Projecting from fill, sq. cut end	0.5
Headwall or headwall and wingwalls	
Socket end of pipe (groove end)	0.2
Square-edge	0.5
Rounded (radius – D/12)	0.2
Mitered to conform to fill slope	0.7
*End-section conforming to fill slope	0.5
Beveled edges, 33.7° or 45° bevels	0.2
Side- or slope-tapered inlet	0.2
Pipe, or Pipe-Arch, Corrugated Metal	
Projecting from fill (no headwall)	0.9
Headwall or headwall and wingwalls square-edge	0.5
Mitered to conform to fill slope, paved or unpaved slope	0.7
*End-section conforming to fill slope	0.5
Beveled edges, 33.7° or 45° bevels	0.2
Side- or slope-tapered inlet	0.2
Box, Reinforced Concrete	
Headwall parallel to embankment (no wingwalls)	
Square-edged on 3 edges	0.5
Rounded on 3 edges to radius of D/12 or B/12 or beveled edges on 3 sides	0.2
Wingwalls at 30° to 75° to barrel	
Square-edged at crown	0.4
Crown edge rounded to radius of D/12 or beveled top edge	0.2
Wingwall at 10° to 25° to barrel	
Square-edged at crown	0.5

Wingwalls parallel (extension of sides)	
Square-edged at crown	0.7
Side- or slope-tapered inlet	0.2

*Note: "End sections conforming to fill slope," made of either metal or concrete, are the sections commonly available from manufacturers. From limited hydraulic tests they are equivalent in operation to a headwall in both inlet and outlet control. Some end sections, incorporating a closed taper in their design have a superior hydraulic performance. These latter sections can be designed using the information given for the beveled inlet.

7.5.2.6 Relative Access Hole Size

K_o is estimated as a function of the relative access hole size and the angle of deflection between the inflow and outflow pipes (see Figure 7.3):

$$K_o = 0.1(b/D_o)(1 - \sin \theta) + 1.4(b/D_o)^{0.15} \sin \theta \tag{7.14}$$

Where:

- b = Access hole diameter, ft
- D_o = Outlet pipe diameter, ft
- q = Angle between inflow and outflow pipes, degrees

7.5.2.7 Pipe Diameter

A change in head loss due to differences in pipe diameter is only significant in pressure-flow situations where the depth in the access hole to outlet pipe diameter ratio, d/D_o , is greater than 3.2. Therefore, it is only applied in such cases as follows:

Figure 7.6 - Pipe diameter

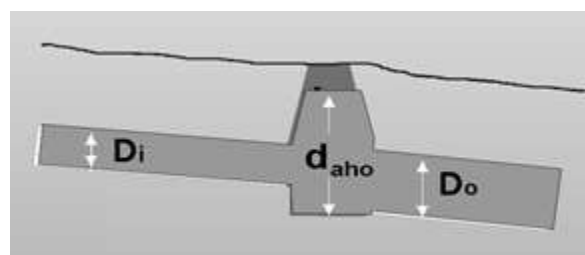

$$C_D = (D_o / D_i)^3 \tag{7.15}$$

Where:

- D_o = Outlet pipe diameter, ft
- D_i = Incoming pipe diameter, ft

7.5.2.8 Flow Depth

The correction factor for flow depth is significant only in free surface flow or low pressures, where the d/D_o ratio is less than 3.2, and is only applied in such cases. Water depth in the access hole is approximated as the level of the hydraulic grade line at the upstream end of the outlet pipe. The correction factor for flow depth, C_d , is calculated by the following:

Figure 7.7 - Flow depth

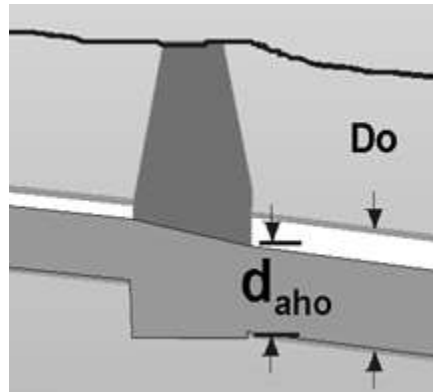

$$C_d = 0.5 \left(\frac{d_{aho}}{D_o} \right)^{0.6}$$

(7.16)

Where:

d_{aho} = Angle between inflow and outflow pipes, degrees

D_o = Outlet pipe diameter, ft

7.5.2.9 Relative Flow

The correction factor for relative flow, C_Q , is a function of the angle of the incoming flow and the percentage of flow coming in through the pipe of interest versus other incoming pipes. It is computed as follows:

$$C_Q = (1 - 2 \sin \theta) \left(1 - \frac{Q_i}{Q_o} \right)^{0.75} + 1$$

(7.17)

Where:

C_Q = Correction factor for relative flow

θ = Angle between the inflow and outflow pipes, degrees

Q_i = Flow in the inflow pipe, ft³/s

Q_o = Flow in the outlet pipe, ft³/s

As can be seen from Equation 7.17, C_Q is a function of the angle of the incoming flow and the percentage of flow coming in through the pipe of interest versus other incoming pipes. To illustrate

this effect, consider the access hole shown in Figure 7.8 and assume the following two cases to determine the impact of Pipe No. 2 entering the access hole:

Figure 7.8 - Relative flow

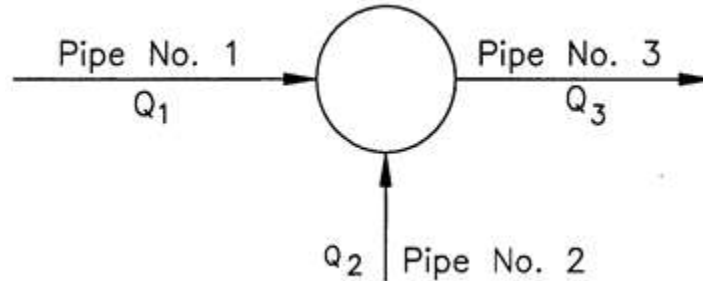

Case 1

$$Q_1 = 3.2 \text{ ft}^3/\text{s}, Q_2 = 1.0 \text{ ft}^3/\text{s}, Q_3 = 4.2 \text{ ft}^3/\text{s}$$

$$C_{Q3-1} = (1 - 2\sin 180^\circ)(1 - 3.2/4.2)^{0.75} + 1 = 1.34$$

Case 2

$$Q_1 = 1.0 \text{ ft}^3/\text{s}, Q_2 = 3.2 \text{ ft}^3/\text{s}, Q_3 = 4.2 \text{ ft}^3/\text{s}$$

$$C_{Q2-1} = (1 - 2\sin 90^\circ)(1 - 3.2/4.2)^{0.75} + 1 = 0.66$$

7.5.2.10 Plunging Flow

This correction factor corresponds to the effect of another inflow pipe or surface flow from an inlet, plunging into the access hole, on the inflow pipe for which the head loss is being calculated. The correction factor is only applied when $h > d$. The correction factor for plunging flow, C_p , is calculated by the following:

$$C_p = 1 + 0.2 \left[\frac{h}{D_o} \right] \left[\frac{(h - d_{aho})}{D_o} \right] \tag{7.18}$$

Where:

- C_p = Correction for plunging flow
- h = Vertical distance from flow line of incoming pipe to center of outlet pipe, ft
- D_o = Outlet pipe diameter, ft
- d_{aho} = Water depth in access hole relative to outlet pipe invert as shown in Figure 7.9, ft

Figure 7.9 - Plunging flow

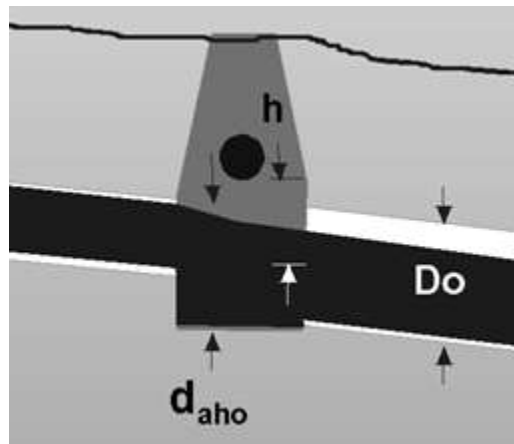

7.5.2.11 Benching

The correction for benching in the access hole, C_B , is obtained from Table 7.8. Benching tends to direct flows through the access hole, resulting in reductions in head loss (Figures 7.10 and 7.11). For flow depths between the submerged and unsubmerged conditions, a linear interpolation is performed. Benching should only be used where energy losses must be kept to a minimum. In areas where energy is not a problem, there is no need to use benching.

Table 7.8—Corrections for benching		
Bench Type	Correction Factors, C_B	
	Submerged*	Unsubmerged**
Flat or depressed floor	1.00	1.00
Half Bench	0.95	0.15
Full Bench	0.75	0.07
Improved	0.40	0.02

*pressure flow, $d/D_o > 3.2$ **free surface flow, $d/D_o < 1.0$

Figure 7.10 - Types of benches

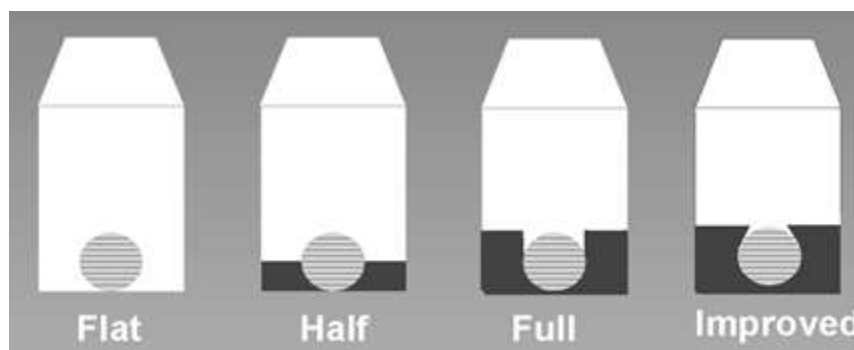

Figure 7.11 - Example of a bench in an access hole

7.5.2.12 Energy Losses

There are other types of energy losses that may be part of the storm drain system, but are not covered here and should be evaluated when present. These losses may be caused by transitions due to expansions and contractions or obstructions. For information on how to handle these losses see HEC 22.

7.6 Energy Grade Line Evaluation Procedure

This section presents a step-by-step procedure for manual calculation of the EGL and the HGL. For most storm drainage systems, computer methods are the most efficient means of evaluating the EGL and the HGL. However, it is important that the designer understand the analysis process in order to better interpret the output from the computer generated storm drain designs.

Figure 7.12 provides a sketch illustrating the use of the two grade lines in developing a storm drainage system. The following section is a step-by-step procedure that can be used to manually compute the EGL and HGL.

Figure 7.12 - Energy and hydraulic grade line illustration

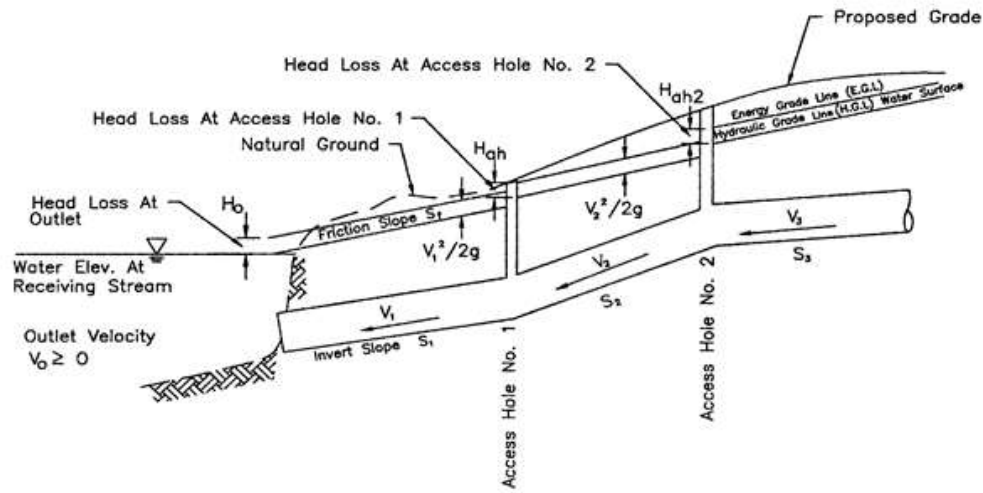

Before outlining the computational steps in the procedure, a comment relative to the organization of data on the form is appropriate. In general, a line will contain the information on a specific structure and the line downstream from the structure. As the table is started, the first two lines may be unique. The first line will contain information about the outlet conditions. This may be a pool elevation or information on a known downstream system. The second line will be used to define the conditions right at the end of the last conduit. Following these first two lines the procedure becomes more general. A single line on the computation sheet is used for each junction or structure and its associated outlet pipe. For example, data for the first structure immediately upstream of the outflow pipe would be tabulated in the third full line of the computation sheet (lines may be skipped on the form for clarity). Table A (Figure 7.13) is used to calculate the HGL and EGL elevations while Table B (Figure 7.14) is used to calculate the pipe losses and structure losses. Values obtained in Table B are transferred to Table A for use during the design procedure. In the description of the computation procedures, a column number will be followed by a letter A or B to indicate the appropriate table to be used.

Figure 7.13 - Energy grade line computation sheet - Table A

ENERGY GRADE LINE COMPUTATION SHEET - TABLE A
(English Solution)

ROUTE _____
SECTION _____
COUNTY _____

COMPUTED BY _____
CHECKED BY _____
PAGE _____
INITIAL TAILWATER ELEV. _____

DATE _____
DATE _____
OF _____

Str. ID	D (ft) (2)	Q (ft ³ /s) (3)	L (ft) (4)	V (fps) (5)	d (ft) (6a)	d _c (6b)	V ² /2g (ft) (7)	S _f (ft/ft) (8)	Total Pipe Loss (table B) (ft) (9)	EGL _o (ft) (10)	K table B (ft) (11)	K(V ² /2g) (ft) (12)	EGL _i (ft) (13)	HGL (ft) (14)	U/S TOC (ft) (15)	Surf. Elev. (ft) (16)	
OUTLET										333.00				333.00			
44													333.07		332.71		332.71
43	2.0	6.75	55.8	2.15	FULL	n/a	0.07	0.0009	0.05	333.12	0.5	0.04	333.16	*333.16	346.06		347.76
43				2.6		0.8	0.10							345.56	345.46	346.06	347.76
42	2.0	6.75	14.1	2.6	1.56	0.80	0.10	0.001	0.014	345.57	0.62	0.06	346.11	346.01	345.73		349.31
41	1.5	5.10	328.0	8.65	0.56	0.85	1.16	-	0	355.79	-	-	355.98	355.10	356.17		360.0
40	1.5	3.35	361.0	7.52	0.43	0.70	0.88		0	-	0	0	366.50	366.50	367.0		370.0

(Above calculations are for inlet end of STR 43 for conduit 42-43)

Figure 7.14 - Energy grade line computation sheet - Table B

ENERGY GRADE LINE COMPUTATION SHEET - TABLE B
(English Solution)

COMPUTED BY _____ DATE _____
 CHECKED BY _____ DATE _____
 PAGE _____ OF _____

ROUTE _____
 SECTION _____
 COUNTY _____

Str. ID (1)	Pipe Losses (ft)					Structure Losses (ft)							K (15)			
	H _f (2)	h _b (3)	H _c (4)	H _e (5)	H _f (6)	Total (7)	d _{ino} (8)	K _o (9)	C _D (10)	C _d (11)	C _g (12)	C _p (13)		C _B (14)		
44																
	0.05					0.05										
43							1.89									0.5
	0.014					0.014										
42							1.40	1.55	1.0	0.40	1.0	1.0	1.0			0.62
						0.0										
41																
																0.0
40							1.0									

EGL computations begin at the outlet and are worked upstream taking each junction into consideration. Many storm drain systems are designed to function in a subcritical flow regime. In subcritical flow or full barrel flow, pipe and access hole losses are summed to determine the upstream EGL levels. **If supercritical flow occurs, pipe and access losses are not carried upstream.** When a storm drain section is identified as being supercritical, the designer should advance to the next upstream pipe section to determine its flow regime. This process continues until the storm drain system returns to a subcritical flow regime.

The EGL computational procedure follows:

Step 1 The first line of Table A includes information on the system beyond the end of the conduit system. Define this as the stream, pool, existing system, etc. in column 1A. Determine the EGL and HGL for the downstream receiving system. If this is a natural body of water, the HGL will be at the water surface. The EGL will also be at the water surface if no velocity is assumed or will be a velocity head above the HGL if there is a velocity in the water body. If the new system is being connected to an existing storm drain system, the EGL and the HGL will be that of the receiving system. Enter the HGL in Column 14A and the EGL in Column 10A of the first line on the computation sheet.

Step 2 Identify the structure number at the outlet (this may be just the end of the conduit, but it needs a structure number), the top of conduit (TOC) elevation at the outlet end, and the surface elevation at the outlet end of the conduit. Place these values in Columns 1A, 15A, and 16A respectively. Also add the structure number in Column 1B.

Step 3 Determine the EGL just upstream of the structure identified in Step 2. Two different cases exist as defined below when the conduit is flowing full:

Case 1: If the TW at the conduit outlet is greater than $(d_c + D)/2$, the EGL will be the TW elevation plus the velocity head for the conduit flow conditions.

Case 2: If the TW at the conduit outlet is less than $(d_c + D)/2$, the EGL will be the HGL plus the velocity head for the conduit flow conditions. The equivalent hydraulic grade line, EHGL, will be the invert plus $(d_c + D)/2$.

The velocity head needed in either Case 1 or Case 2 will be calculated in the next steps, so it may be helpful to complete Step 4 and work Step 5 to the point where velocity head (Column 7A) is determined and then come back and finish this step. Put the EGL in Column 13A.

Note: The values of d_c for circular pipes can be determined from Chart 7.2. Charts for other conduits or other geometric shapes can be found in FHWA publication, *Hydraulic Design of Highway Culverts*, HDS-5, and cannot be greater than the height of the conduit.

Step 4 Identify the structure ID for the junction immediately upstream of the outflow conduit (for the first conduit) or immediately upstream of the last structure (if working with subsequent lines) and enter this value in Columns 1A and 1B of the next line on the

computation sheets. Enter the conduit diameter (D) in Column 2A, the design discharge (Q) in Column 3A, and the conduit length (L) in Column 4A.

Step 5 If the barrel flows full, enter the full flow velocity from continuity in Column 5A and the velocity head ($V^2/2g$) in column 7A. Put "full" in Column 6a and not applicable (n/a) in Column 6B of Table A. Continue with Step 6. If the barrel flows only partially full, continue with Step 5A.

Note: If the pipe is flowing full because of high tailwater or because the pipe has reached its capacity for the existing conditions, the velocity will be computed based on continuity using the design flow and the full cross sectional area. Do not use the full flow velocity determined in Column 15 of the Preliminary Storm Drain Computation Form for part-full flow conditions. For part-full conditions discussed in Step 5, the calculations in the preliminary form may be helpful. Actual flow velocities need to be used in the EGL/HGL calculations.

Step 5A Part-full flow: Using the hydraulic elements graph in Chart 7.5 of HDS-5 with the ratio of part-full to full flow (values from the preliminary storm drain computation form), compute the depth and velocity of flow in the conduit. Enter these values in Column 6A and 5 respectively of Table A. Compute the velocity head ($V^2/2g$) and place in Column 7A.

Step 5B Compute critical depth for the conduit using Chart 7.2 of HDS-5. If the conduit is not circular, see HDS-5 [\(7-4\)](#) for additional charts. Enter this value in Column 6B of Table A.

Step 5C Compare the flow depth in Column 6A (Table A) with the critical depth in Column 6B (Table A) to determine the flow state in the conduit. If the flow depth in Column 6a is greater than the critical depth in Column 6B, the flow is subcritical; continue with Step 6. If the flow depth in Column 6A is less than or equal to the critical depth in Column 6b, the flow is supercritical; continue with Step 5D. In either case, remember that the EGL must be higher upstream for flow to occur. If after checking for super critical flow in the upstream section of pipe, confirm the EGL is higher in the pipe than in the structure.

Step 5D Pipe losses in a supercritical pipe section are not carried upstream. Therefore, enter a zero (0) in Column 7B for this structure.

Step 5E Enter the structure ID for the next upstream structure on the next line in Columns 1A and 1B. Enter the pipe diameter (D), discharge (Q), and conduit length (L) in Columns 2A, 3A, and 4A respectively on the same line.

Note: After a downstream pipe has been determined to flow as supercritical flow, it is necessary to check each succeeding upstream pipe for the type of flow that exists. This is done by calculating normal depth and critical depth for each pipe. If normal depth is less than the diameter of the pipe, the flow will be open channel flow and the critical depth calculation can be used to determine whether the flow is sub- or supercritical. If the flow line elevation through an access hole drops enough that the invert of the upstream pipe is not

inundated by the flow in the downstream pipe, the designer goes back to Step 1A and begins a new design as if the downstream section did not exist.

- Step 5F** Compute normal depth for the conduit using Chart 7.5 and critical depth using Chart 7.2. If the conduit is not circular see HDS-5 (7-4) for additional charts. Enter these values in Columns 6A and 6b of Table A.
- Step 5G** If the pipe barrel flows full, enter the full flow velocity from continuity in Column 5A and the velocity head ($V^2/2g$) in Column 7A. Go to Step 3, Case 2 to determine the EGL at the outlet end of the pipe. Put this value in Column 10A and go to Step 6. For part-full flow, continue with Step 5H.
- Step 5H** Part-full flow: Compute the velocity of flow in the conduit and enter this value in Column 5A. Compute the velocity head ($V^2/2g$) and place in Column 7A.
- Step 5I** Compare the flow depth in Column 6A with the critical depth in Column 6B to determine the flow state in the conduit. If the flow depth in Column 6A is greater than the critical depth in Column 6B, the flow is subcritical; continue with Step 5J. If the flow depth in Column 6A is less than or equal to the critical depth in Column 6B, the flow is supercritical; continue with Step 5K.
- Step 5J** Subcritical flow upstream: Compute EGL_o at the outlet of the previous structure as the outlet invert plus the sum of the outlet pipe flow depth and the velocity head. Place this value in Column 10A of the appropriate structure and go to Step 9.
- Step 5K** Supercritical flow upstream: Access hole losses do not apply when the flow in two (2) successive pipes is supercritical. Place zeros (0) in Columns 11A, 12A, and 15B of the intermediate structure (previous line). The HGL at the structure is equal to the pipe invert elevation plus the flow depth. Check the invert elevations and the flow depths upstream and downstream of the structure to determine where the highest HGL exists. The highest value should be placed in Column 14A of the previous structure line. Perform Steps 20 and 21 and then repeat Steps 5E through 5K until the flow regime returns to subcritical. If the next upstream structure is end-of-line, skip to step 10b then perform Steps 20, 21, and 24.
- Step 6** Compute the friction slope (S_f) for the pipe using Equation 7.12:
- $$S_f = H_f / L = [Q n / (0.463 D^{2.67})]^2$$
- Enter this value in Column 8A of the current line. Equation 7.12 assumes full flow in the outlet pipe. If full flow does not exist, set the friction slope equal to the pipe slope.
- Step 7** Compute the friction loss (H_f) by multiplying the length (L) in Column 4A by the friction slope (S_f) in Column 8A and enter this value in Column 2B. Compute other losses along the pipe run such as bend losses (h_b), transition contraction (H_c) and expansion (H_e) losses, and junction losses (H_j) and place the values in Columns 3B, 4B, 5B, and 6B, respectively. Add the values in 2B, 3B, 4B, 5B, and 6B and place the total in Column 7B and 9A.

- Step 8** Compute the energy grade line value at the outlet of the structure (EGL_o) as the EGL_i elevation from the previous structure (Column 13A) plus the total pipe losses (Column 9A). Enter the EGL_o in Column 10A.
- Step 9** Estimate the depth of water in the access hole (estimated as the depth from the outlet pipe invert to the hydraulic grade line in the pipe at the outlet). The depth of water in the access hole is computed as EGL_o (Column 10A) minus the pipe velocity head in Column 7A minus the pipe invert elevation (from the preliminary storm drain computation form). Enter this value in Column 8B. If supercritical flow exists in this structure, leave this value blank and skip to Step 5E.
- Step 10** If the inflow storm drain invert is submerged by the water level in the access hole, compute access hole losses using Equations 7.16 and 7.17. Start by computing the initial structure head loss coefficient, K_o , based on relative access hole size. Enter this value in Column 9B. Continue with Step 11. If the inflow storm drain invert is not submerged by the water level in the access hole, compute the head in the access hole using culvert techniques from HDS-5 [\(7-4\)](#) as follows:
- If the structure outflow pipe is flowing full or partially full under outlet control, compute the access hole loss by setting K in Equation 7.16 to K_e as reported in Table 7.6. Enter this value in Column 15B and 11A, continue with Step 17. Add a note on Table A indicating that this is a drop structure.
 - If the outflow pipe functions under inlet control, compute the depth in the access hole (HGL) using Chart 7.3 or 7.4. If the storm conduit shape is other than circular, select the appropriate inlet control nomograph from HDS-5. [\(7-4\)](#) Add these values to the access hole invert to determine the HGL. Since the velocity in the access hole is negligible, the EGL and HGL are the same. Enter HGL in Column 14A and EGL in Column 13A. Add a note on Table A indicating that this is a drop structure. Go to Step 20.
- Step 11** Using Equation 7.19 compute the correction factor for pipe diameter, C_D , and enter this value in Column 10B. This factor is only significant in cases where the d_{aho}/D_o ratio is greater than 3.2.
- Step 12** Using Equation 7.20 compute the correction factor for flow depth, C_d , and enter this value in Column 11B. This factor is only significant in cases where the d_{aho}/D_o ratio is less than 3.2.
- Step 13** Using Equation 7.21, compute the correction factor for relative flow, C_Q , and enter this value in Column 12B. This factor equals 1.0 if there are less than 3 pipes at the structure.
- Step 14** Using Equation 7.22, compute the correction factor for plunging flow, C_p , and enter this value in Column 13B. This factor equals 1.0 if there is no plunging flow. This correction factor is only applied when $h > d_{aho}$.
- Step 15** Enter in Column 14B the correction factor for benching, C_B , as determined from Table 7.7. Linear interpolation between the two columns of values will most likely be necessary.

- Step 16** Using Equation 7.17, compute the value of K and enter this value in Column 15B and 11A.
- Step 17** Compute the total access hole loss, H_{ah} , by multiplying the K value in Column 11A by the velocity head in Column 7A. Enter this value in Column 12A.
- Step 18** Compute EGL_i at the structure by adding the structure losses in Column 12A to the EGL_o value in Column 10A. Enter this value in Column 13A.
- Step 19** Compute the HGL at the structure by subtracting the velocity head in Column 7A from the EGL_i value in Column 13A. Enter this value in Column 14A.
- Step 20** Determine the TOC value for the inflow pipe (using information from the storm drain computation sheet) and enter this value in Column 15A.
- Step 21** Enter the ground surface, top of grate elevation or other high water limits at the structure in Column 16A. If the HGL value in Column 14A exceeds the limiting elevation, design modifications will be required.
- Step 22** Enter the structure ID for the next upstream structure in Column 1A and 1B of the next line. When starting a new branch line, skip to Step 24.
- Step 23** Continue to determine the EGL through the system by repeating Steps 4 through 23. (Begin with Step 2 if working with a drop structure. This begins the design process again as if there were no system downstream from the drop structure).
- Step 24** When starting a new branch line, enter the structure ID for the branch structure in Columns 1A and 1B of a new line. Transfer the values from Columns 2A through 10A and 2B to 7B associated with this structure on the main branch run to the corresponding columns for the branch line. If flow in the main storm drain at the branch point is subcritical, continue with Step 9; if supercritical, continue with Step 5E.

7.7 Computer Programs

A variety of computer programs are available to facilitate storm drain design. The use of any of these programs is acceptable, provided the program substantially conforms to the theory and methods described in HEC 22.

7.8 Additional Guidance

The components and guidelines listed below should be considered unless determined not to be applicable:

- Flap Gates. When necessary, backflow protection should be provided in the form of flap gates. These gates offer negligible resistance to the release of water from the system, and their effect upon the hydraulics of the system may be neglected.
- Perforated underdrain pipe should be placed in areas where a subsurface permeable layer is needed. See Ga. Std. 9029B; located at the GDOT Construction Standards web page

- (<http://mydocs.dot.ga.gov/info/gdotpubs/ConstructionStandardsAndDetails/Forms/AllItems.aspx>). Example locations include under curb and gutter sections at the low side of superelevation and at low points of sag vertical curves on tangent sections.
- In an effort to minimize excavation costs, a storm drain should be designed as close to the surface as possible while meeting minimum cover and/or hydraulic requirements.
- Tip: Coordinate with utility locations. Gravity systems such as sanitary sewers should be closely checked for conflicts. Pressure fed systems like water and gas can usually be routed to avoid the gravity flow systems.

7.9 Represent Drainage Design on the Plans

In addition to documenting drainage design, the following information must be prepared and presented on the construction plan set:

- Drainage profiles and quantities as per the plan presentation guide.
- The pipe selection table from the soils report (typically shown on the drainage quantity sheet).

Chapter 7 References

1. American Association of State Highway and Transportation Officials (AASHTO). 2005. Model Drainage Manual, 3rd Ed.
2. American Concrete Pipe Association (ACPA). 2011. [Concrete Pipe Design Manual](#).
3. Brown, S.A., Schall, J.D., Morris, J.L., Doherty, C.L., Stein, S.M., Warner, J.C. 2009, Urban Drainage Design Manual, [Hydraulic Engineering Circular No. 22](#), FHWA-NHI-10-009. Federal Highway Administration (FHWA), U.S. Department of Transportation, Washington, D.C.
4. Schall, James D., Thompson, Philip L., Zerges, Steve M., Kilgore, Roger T., Morris, Johnny L. 2012, Hydraulic Design of Highway Culverts Third Edition, [Hydraulic Design Series No. 5](#), FHWA-HIF-12-026. Federal Highway Administration (FHWA), U.S. Department of Transportation, Washington, D.C.
5. Tennessee Department of Transportation (TDOT). 2013. [Drainage Manual](#). Roadway Design Division.

Intentionally Left Blank

Chapter 8. Culverts - Contents

Chapter 8. Culverts - Contents8-i

8.1 Introduction.....8-1

8.1.1 Definition8-1

8.1.2 Symbols.....8-1

8.2 Design Guidelines8-3

8.2.1 General Requirements8-3

8.2.2 Design Storm Event8-5

8.2.3 Allowable Headwater.....8-5

8.2.4 Tailwater Relationship8-7

8.2.5 Maximum Outlet Velocity / Energy Dissipators8-7

8.2.6 Aquatic Organism Passage (AOP).....8-8

8.2.7 Minimum Velocity8-12

8.2.8 Minimum Required Cover and Clearances8-12

8.2.9 Improved Inlets.....8-12

8.2.10 Culvert Extensions8-12

8.2.11 Channel Changes.....8-13

8.2.12 Pipe Culverts8-13

8.2.13 Box Culverts8-14

8.2.14 Bottomless Culverts8-15

8.2.15 Fall.....8-15

8.2.16 Acceptable Culvert Design Methods8-15

8.2.17 Hydraulic Reports.....8-15

8.2.18 Culverts Located Within a FEMA Regulatory Floodway.....8-16

8.3 Typical Information Needed for Design8-16

8.4 Culvert Design Approach.....8-16

8.4.1 Types of Control.....8-17

8.5 Culvert Design Method8-30

8.5.1 Culvert Design Method.....8-30

8.5.2 Inlet Control Calculations8-31

8.5.3 Outlet Control Calculations.....8-37

8.5.4 Evaluation of Results.....8-40

8.5.5 Energy Dissipation8-40

8.5.6 Culvert Outlet Velocity and Velocity Modification8-41

8.5.7 Outlet Velocity Considerations for Culverts on Mild Slopes8-41

8.5.8 Outlet Velocity Considerations for Culverts on Steep Slopes.....8-42

8.5.9 Types of Energy Dissipation.....8-42

8.5.9.1	Hydraulic Jump Energy Dissipators	8-42
8.5.9.2	Impact Basins.....	8-43
8.5.9.3	Drop Structures With Energy Dissipation	8-44
8.5.9.4	Stilling Wells	8-45
8.5.9.5	Riprap Stilling Basins	8-45
8.6	Design Software	8-46
8.6.1	Culvert Design Using HY-8	8-46
Chapter 8 References.....		8-49

Chapter 8. Culverts

8.1 Introduction

This chapter provides design procedures for the hydraulic design of highway culverts that are based on FHWA Hydraulic Design Series No. 5 (HDS 5), Hydraulic Design of Highway Culverts. (8-7) (http://www.fhwa.dot.gov/engineering/hydraulics/library_listing.cfm). This chapter also includes the following:

- Results of the culvert analysis using the HY-8 culvert analysis software (8-4)
- Summary of the design philosophy contained in the AASHTO Highway Drainage Guidelines, Chapter 4 (8-1)

8.1.1 Definition

A culvert is a drainage structure primarily used to convey surface water through embankments that are often constructed in a variety of shapes, sizes, and various materials. Culverts are defined according to their shape, size, material type, and usage. For example, a culvert can be defined as a twin 10-ft X 10-ft concrete box culvert, an 18-inch corrugated metal pipe (CMP) side-drain culvert, or a 36-inch reinforced concrete pipe (RCP) cross-drain culvert.

Culverts are distinguished from bridges in that they are usually covered with embankment material and are composed of structural material around the entire perimeter, although some are bottomless. Box, pipe, or arched culverts that have a clear span width of 20 ft or less, as measured parallel to the roadway centerline between the outermost hydraulic ends, are considered to be a culvert by definition.

For box, pipe, or arched culverts with a clear-span width greater than 20 ft, the culvert is defined as a bridge culvert and located in the bridge category for design criteria. For example, a dual 10-ft X 10-ft box culvert with a 1-ft wide center wall that has a total clear span width of 21 ft is considered a bridge culvert. Refer to chapter 12 of this manual for more information on bridge design for a bridge culvert.

One exception to the 20-ft clear span width limit is a multi-barrel pipe culvert. Multi-barrel pipe culverts may exceed the 20-ft clear span width and still be called a culvert if the spacing between the culverts is greater than half a barrel diameter. Alternatively, a skewed (or angled) structure would be considered a bridge culvert when its clear-span width measured parallel to the roadway centerline is greater than 20 ft.

Hydraulic structures in this chapter as defined by their clear-span width criteria are designed hydraulically as a culvert and treated as such in this chapter.

8.1.2 Symbols

To provide consistency within this chapter and throughout this manual, the symbols given in Table 8.1 will be used. These symbols were selected because of their wide use in culvert publications

Table 8.1 Symbols and definitions

Symbol	Definition	Units
A	Area of cross section of flow	ft ²
AHW	Allowable HW	ft
B	Barrel width	in or ft
D	Culvert diameter or barrel height	in or ft
d	Depth of flow	ft
d _c	Critical depth of flow	ft
g	Acceleration due to gravity	ft/s ²
H	Sum of H _E + H _f + H _v	ft
H _b	Bend head loss	ft
H _E	Entrance head loss	ft
H _f	Friction head loss	ft
H _L	Total energy losses	ft
H _o	Outlet or exit head loss	ft
H _v	Velocity head	ft
h _o	Hydraulic grade line height above outlet invert	ft
HW	Headwater depth (subscript indicates section)	ft
k _E	Entrance loss coefficient	-
L	Length of culvert	ft
n	Manning's roughness coefficient	-
P	Wetted perimeter	ft
Q	Rate of discharge	ft ³ /s
R	Hydraulic radius (A/P)	ft
S	Slope of culvert	ft/ft
TW	Tailwater depth above invert of culvert	ft

V	Mean velocity of flow with barrel full	ft/s
V_d	Mean velocity in downstream channel	ft/s
V_o	Mean velocity of flow at culvert outlet	ft/s
V_u	Mean velocity in upstream channel	ft/s
g	Unit weight of water	lb/ft ³
t	Tractive force	lb/ft ²

8.2 Design Guidelines

8.2.1 General Requirements

The following guidelines are provided for guidance in the design of culverts:

- All culverts shall be hydraulically designed by this guideline.
- HY-8 and the HEC-RAS culvert modules are the only computer programs allowed for the hydraulic analysis of a culvert. The FHWA HDS 5 *Hydraulic Design of Highway Culverts* is also acceptable and available from the FHWA website.
- HY-8 and the HEC-RAS culvert module have design limitations if the structure span approaches 20 ft. Therefore, in designing a replacement culvert where the existing structure has a span of 20 ft or greater measured perpendicular to flow, only the HEC-RAS bridge module should be used for hydraulic analysis. The existing and proposed structures should be analyzed using the same module.
- Survey information shall include topographic features, channel characteristics, aquatic life, high-water information, existing structures, and other related site-specific information.
- The design flow and the corresponding headwater elevation for the design flow should be shown on the construction plans for all road culverts.
- For projects funded with federal funds, section 650.117 of 23 Code of Federal Regulations (CFR) 650A applies and requires that project plans for encroachment locations contain the following:
 - (1) The magnitude, approximate probability of exceedance, and at appropriate locations, the water surface elevations associated with the overtopping storm event or the storm of Sec. 650.115(a)(1) [\(8-3\)](#) (*the largest storm event that may be reasonably estimated such as the 500-year storm event*).
 - (2) The magnitude and water surface elevation of the base storm event, if larger than the overtopping storm. [\(8-3\)](#) (*The base storm event is the 100-year storm event*).

Note: The overtopping storm event does not need to correspond with the design frequency for which the culvert is designed. The culvert should be designed for the event given in section 8.2.2 *Design Storm Event*.

- Special construction considerations should be made where a cross drain is located in or near a wetland in order to not drain the wetland (e.g. culvert embedment, bedding material, etc.).
- All new culverts (pipe and box culverts) shall be designed for a beveled edge as shown in the standard drawings. Note that the grooved end (bell end), if left in place, may be a substitute for the bevel.
- Unless a specific material is specified, all calculations shall be performed assuming concrete will be used. If the contractor elects to use an alternate material, the structure must be checked and resized as necessary. The proper Manning's n for the culvert material (concrete, metal, plastic, etc.) must be used.
- The detail of documentation for each culvert site shall be commensurate with the risk and importance of the structure. Design data and calculations shall be assembled in an orderly fashion and retained for future reference.
- Any culvert spanning a clear distance of 20 ft or greater along the roadway centerline is to be classified as a bridge culvert in the plans, with the exception of multi-barrel pipe culverts (as noted in section 8.1.1). See chapter 12 of this manual for analyses pertaining to bridge culverts.
- The quantity of baffles for embedded culverts with baffles needs to be included in the summary of quantities sheet as well as which culverts need the detail noted in Section 22 of the plans.
- Culverts less than or equal to 30 inches in diameter shall be subject to one of the following criteria:
 - Be extended to the appropriate "clear zone" distance per AASHTO Roadside Design Guide. An end section appropriate to the culvert material shall be used; e.g., a flared end section (Ga. Std. 1120).
 - Safety treated with a grate such as GDOT Construction Detail D-5 if one of the ends is within the "clear zone."
- Culverts greater than 30 inches in diameter shall be subject to one of the following criteria:
 - Be extended to the appropriate "clear zone" distance per AASHTO Roadside Design Guide. An end section appropriate to the culvert material shall be used.
 - Safety treated with a grate if the consequences of clogging and causing a potential flooding hazard are less than the hazard of vehicles impacting an unprotected end. (See GDOT Construction Detail D-6 for fabrication details for the safety grate.) If this option is used, maintenance is recommended to periodically inspect each site and remove debris.

- Shielded with a traffic barrier if the culvert is very large, cannot be extended, has a channel that cannot be safely traversed by a vehicle, or has a significant flooding hazard with a grate.

8.2.2 Design Storm Event

Culverts are to be sized to accommodate the following storm events without exceeding the design storm headwater.

- Interstate and state routes: All culverts crossing interstate and state routes shall be designed to meet the headwater and roadway profile elevation criteria listed in Table 8.2 for the 50-year storm event. Culverts shall also be designed to convey the 100-year storm without roadway overtopping.
- Roads not designated as state routes: All culverts crossing a roadway not designated as an interstate or state route shall be designed to meet the minimum headwater and roadway profile elevation criteria listed in Table 8.2 for the design storm frequency based on ADT. Although Table 8.2 lists minimum design frequencies less than the 25-year storm event for roads with an ADT of 400 or less, the 25-year storm event is still recommended as a minimum design guideline.
- Driveway pipe culverts: All driveway pipe culverts (side drain pipes) shall be designed for the 25-year frequency storm. All driveway pipes shall be checked to confirm that the headwater for the 100-year event does not violate the overtopping requirements for the adjacent roadway.
- Temporary cross drains: All temporary cross drains shall be designed based on a 10-year storm frequency.

It is important to note that the roadway will overtop at the nearest low point on the roadway, which does not necessarily correspond with the roadway elevation shown on the drainage cross section. The design storm frequency and other criteria for culverts are also summarized in Table 8.2.

8.2.3 Allowable Headwater

The allowable headwater depth (HW_d), sometimes called the available head, is the depth of water that can be ponded at the upstream end of the culvert during the design-year storm, and is limited by one or more of the following:

- To protect the roadway pavement, the minimum allowable freeboard shall be 1 ft as measured from the bottom of the pavement structure to the design-year HW elevation.
- The HW elevation should not be greater than the elevation at which flow diverts around the culvert.
- For streams with a FEMA designated floodway or in communities that participate in the NFIP, see chapter 2 of this manual for guidance in establishing the HW elevation.
- For drainage basins equal to or less than 200 acres, the HW_d should not be greater than 1.5D, where D is the diameter or depth of the culvert. However, certain conditions allow for the HW_d to be up to 2D (See HEC 10 for conditional information or section 2.6.1 of this manual for additional backwater limitations).

The allowable headwater and other design criteria for culverts are summarized in Table 8.2.

Table 8.2 Culvert design criteria				
Facility	Primary Criteria Roadway Base or Culvert Crown Elevation		Secondary Criteria Shoulder Breakpoint or Culvert Crown Elevation	
	Required Clearance (ft)	Design Storm Frequency	Required Clearance (ft)	Check Storm Frequency
Interstates & State Routes	1.0	⁽¹⁾ 50-yr	1.0 ft below breakpoint	100-yr
Hurricane Evacuation Routes	1.0	50-yr	1.0 ft below breakpoint	100-yr
Non-state Routes: ADT = 0-99 ADT = 100-399 ADT = 400-1499 ADT > 1499	1.0 1.0 1.0 1.0	5-yr 10-yr 25-yr 50-yr	1.0 ft below breakpoint 1.0 ft below breakpoint 1.0 ft below breakpoint 1.0 ft below breakpoint	10-yr 25-yr 50-yr 100-yr
Driveways	1.0	25-yr	break point not overtopped	50-yr
Temporary Detours	1.0	10-yr	break point not overtopped	25-yr
Permanent Culverts	2.0	50-yr	1 ft of crown clearance	100-yr
Temporary Culverts: Local roads, ADT < 400 All other roads	1.0 1.0	2-yr 10-yr	crown not overtopped crown not overtopped	5-yr 25-yr

Note 1: Both the primary criteria and secondary criteria must be met with the more conservative of the two criteria controlling the maximum headwater elevation

Note 2: Culvert headwater must be checked for road overtopping using the 100-year design storm event.

8.2.4 Tailwater Relationship

Tailwater relationships vary depending on the particular scenario. The two most common are for channels and larger water bodies, including confluences. The following sections discuss each of these scenarios and provide additional information.

Tailwater Relations for Channels

- Evaluate the hydraulic conditions of the downstream channel to determine the tailwater depths for all design flows and the average annual perennial stream flows (see chapter 5 of this manual).
- For a subcritical hydraulic analysis, use backwater curves or a single, cross-section analysis.
- Use the headwater elevation of any nearby, downstream culvert if it is greater than the depth of flow in the channel.

Confluence or Large-Water Body

- For tributary tailwater conditions, use the backwater elevation of the main stream.
- For two separate rainfall events that occur within the same watershed and both events are independent of one another, use the higher tailwater condition that estimates a reasonable backwater elevation.
- If tidal conditions are present, use the mean high tide. For design methods and requirements for culverts located within a tidal area, see chapter 12 of this manual.

8.2.5 Maximum Outlet Velocity / Energy Dissipators

The maximum velocity at the culvert outlet should be examined on a case-by-case basis, which may include a sediment transport calculation examining the streambed shearing stress of the sediment. For culverts that operate with velocities greater than 10 ft/s, downstream scour and erosion can become problematic. The culvert design methodology (discussed in section 8.5) does not control the outlet velocity in total. The slope, type of material, tailwater, and other factors can also affect the velocity. See the design methodology section for more details.

If the velocity discharged from the culvert is greater than the velocity in a downstream natural channel for the design flow, the following should be considered:

- Channel stabilization
- Energy dissipation

Scour holes at culvert outlets provide efficient energy dissipators. As such, outlet protection for the design storm event should be provided where the outlet scour hole depth computations indicate that the scour hole:

- Will undermine the culvert outlet
- May cause costly property damage
- Causes a nuisance effect (most common in urban areas)

- Blocks aquatic life stream sustainability
- Will restrict land-use requirements

An energy dissipator should be used at culvert outlets when outlet velocities become excessive for site conditions and downstream scour becomes problematic. (See FHWA HEC 14 *Hydraulic Design of Energy Dissipators for Culverts and Channels* [\(8-9\)](#) for scour computations and design of energy dissipators.)

8.2.6 Aquatic Organism Passage (AOP)

At many culvert locations, the ability of the structure to accommodate aquatic organisms and migrating fish is an important design consideration. A primary concern is ecological connectivity between upstream and downstream channels. Design criteria often includes minimum flow depths, maximum velocity, natural channel inverts, resting areas in long barrels, and no perched outlets. Minimizing the amount of contraction at the culvert inlet is also an important design component for AOP. [\(8-7\)](#) Some situations may even require the construction of a bridge spanning the natural stream. However, culvert modifications can often be constructed to meet the design criteria established by the fish and wildlife agencies, such as the requirements set forth in the USACE's regional permit. [\(8-10\)](#)

The smooth sides and bottom of a standard box culvert, circular pipe, or elliptical pipe tend to accelerate velocity of water passing through the culvert. These higher velocities increase erosion at the entrance and exit of the culvert and can cause the invert of the culvert to become perched. The perched invert and increased velocities both create barriers for aquatic life to pass through the culvert. Designing the culvert for AOP reduces the likelihood that the culvert will become perched and generates flow velocities that closely match the flow characteristics of the surrounding stream.

There are several methods by which to design culverts for AOP. The most common design methods are: [\(8-7\)](#)

- Stream Simulation Methods
 - US Forest Service (USFS) Stream Simulation Method [\(8-8\)](#)
 - FHWA HEC 26 Stream Simulation Method [\(8-6\)](#)
- Simplified Method

The premise of either stream simulation method is to mimic the slope, structure, and dimensions of the natural streambed. Since it has similar characteristics to the natural channel, aquatic species should not experience difficulty passing through the stream simulation. [\(8-8\)](#) For more information on the USFS Stream Simulation Method, see the latest revision of *Stream Simulation: An Ecological Approach to Providing Passage for Aquatic Organisms at Road-Stream Crossings*.

The HEC 26 simulation method uses sediment behavior within the streambed as its primary parameter. The idea of using sediment behavior as a model criterion is that aquatic organisms in the stream are exposed to similar forces experienced by the streambed material. The end goal is to design a stream crossing with an equivalent effect. If all conditions are determined to be the same, then the newly designed stream crossing should not present an obstacle to aquatic organisms. [\(8-6\)](#) Accompanying HEC 26 is an FHWA developed Microsoft Excel spreadsheet used to incorporate AOP culvert design procedures found here:

www.fhwa.dot.gov/engineering/hydraulics/software/hect26/index.cfm.

The requirements set forth in the USACE permit most closely resemble the simplified method, which is also the most commonly used. (8-10) The USACE method requires an embedment depth of 20% of the culvert rise height where the Etowah HCP culvert design policy requires an embedment depth of 30%-50% of the rise height.

The following are design guidelines for complying with the USACE AOP requirements and the Savannah District's current Regional Conditions. (8-10) The designer must coordinate with the project ecologist in determining whether any given stream crossing is to be designed for AOP. As with most guidelines, there may be site-specific circumstances where it is not appropriate to design for AOP. This guidance does not relieve the designer from the responsibility of using engineering judgment to determine the appropriateness of designing for AOP for any given circumstance.

There are two cases of stream crossing types where AOP is required. The first is for new installations or replacements and the second is for retrofitting. New installations and replacements offer the flexibility to vary the type, size, shape, alignment, and bed material of the new culvert. Retrofits are limited on options due to the constraints of existing field conditions.

General AOP Guidelines for Culverts on Perennial Streams

1. Culverts should not permanently widen or constrict the channel and should not reduce or increase stream depth. The width of the base flow culvert(s) should be equal to the average channel width. Multiple pipe culverts should not be used to receive base flows.
2. Bank-full flows should be accommodated through maintenance of the existing bank-full, cross-sectional area.

Figure 8.1 - Culvert embedment (8-10)

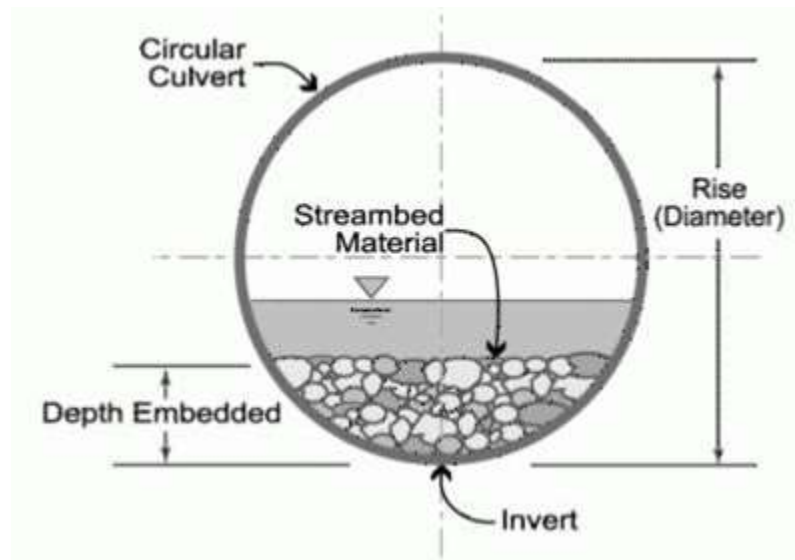

3. Both inverts of culverts, except bottomless culverts, need to be buried or embedded to a depth of 20% of the culvert height to allow the natural substrate to colonize the structure's bottom and encourage fish movement. An example of embedment for a circular culvert is illustrated in Figure 8.1.

4. Culvert slope should be consistent with average stream segment slope, but should not exceed 4%.
5. Culverts should be an adequate size to accommodate flow in such a way that does not cause flooding of associated uplands or disruption of hydrologic characteristics that support aquatic sites on either side of the culvert.
6. Where adjacent floodplain is available, flows that exceed bank-full conditions should be accommodated by installing an equalizer culvert at the floodplain elevation.
7. Unless specifically described in the USACE's Pre-Construction Notification (PCN), the use of an undersized culvert to attain stormwater management or waste treatment is not authorized. [\(8-10\)](#)

Bridges and Bottomless Culverts for AOP

Bridges and bottomless culverts cause minimal or temporary impacts to AOP. However, these structures should be assessed with a stream simulation method to evaluate the geomorphic and hydraulic parameters that affect AOP for proper stream placement. See section 8.2.14 for additional information on bottomless culverts.

Photograph 8.1 is an image of a bottomless culvert. It is important to note that there is room for the stream to meander somewhat and there is no change in stream bed material. The impacts to the stream as a result of this culvert installation are minimal.

Photograph 8.1 - Bottomless culvert [\(8-7\)](#)



Box and Pipe Culverts for AOP

Circular or irregular pipes and box culverts both inherently have an artificial bottom surface that is not the same material or nature as that of the surrounding streambed. For this reason, the embedment requirements of the USACE's Regional Conditions will apply. Photograph 8.2 shows an embedded box culvert designed to comply with the USACE embedment requirements.

Photograph 8.2 - Embedded box culvert

Designing Box Culverts for AOP

1. Select a standard culvert width that most closely matches the average top of bank to the top of bank width of the stream for the portion of stream that is to flow through the culvert.
2. Calculate the height of the culvert needed to pass the design and check storm events. Increase this height by 20% (rounded up to the nearest foot) to include the required buried depth to determine the final height of the proposed box culvert. A composite Manning's n value will need to be calculated to account for differing n values between the natural stream material on the bottom and smooth concrete sides of the culvert. See section 4.2.6.3 of this manual for suggested methods on calculating the weighted Manning's n coefficient.
3. If a single- or multi-barrel box culvert that matches the stream bank to stream bank width of the culvert is unable to pass the required storm event, additional flanking structures may be placed vertically higher up in the floodplain near the culvert. These additional flanking structures do not need to be embedded. Care must be taken to be certain that the flanking structures do not cause scour or flooding issues.
4. In areas with high bedrock, it may be economically more feasible to construct a bottomless box culvert directly onto bedrock than to install a box culvert since the bedrock needs to be approximately 4 ft below the bottom of the streambed to avoid blasting. [\(8-7\)](#) Consult with the GDOT Bridge Design Office for special culvert design on bedrock.
5. Embedded box culverts should be assessed for inclusion of the fish baffle detail (D-48) found on the GDOT details webpage.

Figure 8.2 - Culvert barrel partially buried to preserve natural stream bed

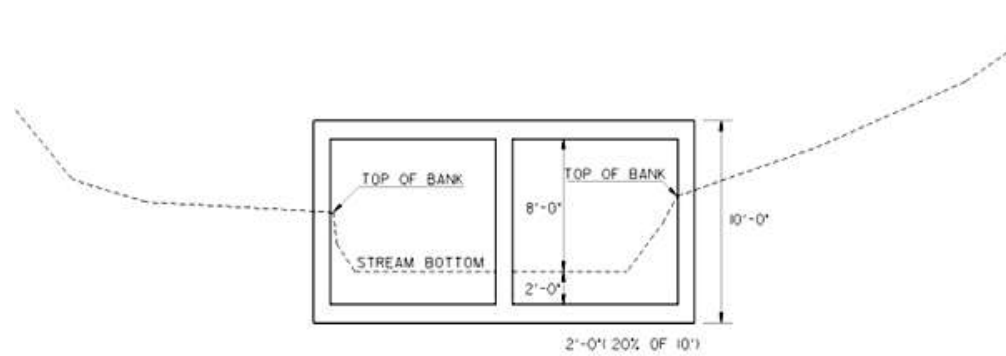

When designing flanking structures, the non-embedded flanking structure is generally more hydraulically efficient and will tend to carry more flow than the embedded structure. To design parallel, dissimilar culverts, it is necessary to construct separate performance curves (elevation versus discharge) for each culvert. The two performance curves are added together at equal elevations to obtain the combined performance curve. This technique is described in FHWA's HDS 5 (8-7) for multiple-barrel culverts with unequal invert elevations.

8.2.7 Minimum Velocity

The minimum velocity in the culvert barrel should result in a tractive force ($t = \gamma dS$) greater than the critical shear stress of the transported streambed material at low-flow rates.

- Use 3 ft/s when the streambed material size is not known.
- If clogging is probable, consider a size of culvert to facilitate cleaning or increase the slope of the pipe.

8.2.8 Minimum Required Cover and Clearances

All pipe and box culverts shall have a minimum cover of 1 ft. The minimum roadway clearance over a culvert shall be 1 ft measured from the bottom of the pavement structure to the exterior crown of the culvert. Underground utilities shall have a minimum clearance of 0.5 ft from the exterior crown of the culvert.

8.2.9 Improved Inlets

Economic considerations are important factors in determining the use of inlet improvement beyond the standard beveled edge. Such improvements should be evaluated comparing costs and benefits.

8.2.10 Culvert Extensions

All culvert extensions should be evaluated using the hydraulic principles discussed in this chapter. Where culverts have bends and transitions, they may be analyzed as if they are storm drains. Energy losses within the culvert barrel will need to be considered for all bends and transitions when the culvert is operating in outlet control. See FHWA's Hydraulic Engineering Circular 22 for transition and bend losses.

Culverts shall only be extended with barrel sizes that are equal to or greater than the existing culvert barrel size. If additional fill is being placed on an existing culvert, the designer must confirm that the culvert can handle the weight of the additional fill.

Culvert extensions should be made along the same alignment as the existing culvert barrel. When it is not possible or feasible to extend a culvert along the same alignment as the existing culvert, then the maximum allowable deflection angle from the existing culvert alignment shall be 30 degrees.

Extensions requiring multiple bends shall be limited to a 15 degree maximum deflection angle at each bend and a minimum distance of 20 ft before the next deflection.

A circular pipe used to extend a box culvert shall have a diameter equal to or greater than the diagonal measurement of the box culvert.

8.2.11 Channel Changes

To reduce potential environmental mitigation requirements and to minimize costs associated with structural excavation and/or channel work; channel changes should be avoided if at all possible. In cases when a channel change is necessary and cannot be avoided, then abrupt stream transitions at either end of the culvert should be avoided. Environmental coordination and permitting will be required for any necessary channel modifications.

8.2.12 Pipe Culverts

Pipe culverts that cross under a roadway or driveway shall have a minimum diameter of 18 inches provided that the required amount of cover is achieved.

For allowable end treatments for pipe culverts, see Table 8.3.

Pipe culvert material alternates shall be as recommended by The Office of Materials and Research in the project soil survey summary. These recommendations shall be shown in the plans. See the GDOT Geotechnical Manual section 4.5.26 for the Pipe Culvert Material Alternates table. When alternate materials are used that are different from what is assumed in the design calculations, the contractor must perform a hydraulic analysis to account for the different roughness factors. Different materials may require different size structures.

Table 8.3. Pipe culvert end treatments	
ADT < 400	<ul style="list-style-type: none"> a. Use rip rap, flared end sections or safety end sections for velocities less than 12 ft/s for pipes less than 48 inches in diameter (See chapter 9 of this manual for riprap design information). b. An outlet headwall should be used for velocities greater than or equal to 12 ft/s for all pipes 48 inches in diameter or larger. c. Pipes less than 48 inches with projecting ends or ends mitered to the fill slope (no headwall) may be used at select locations. d. Pipes 48 inches or greater in diameter shall require concrete headwalls on the inlet to anchor and protect them.
ADT < 1500	<ul style="list-style-type: none"> a. Flared end sections or safety end sections are the recommended pipe culvert end treatments for velocities less than 12 ft/s for pipes less than 48 inches in diameter. The use of sand-cement bag rip rap on smaller than 48-inch pipes is also an acceptable end treatment. b. An outlet headwall should be used for velocities greater than or equal to 12 ft/s. c. Pipes with projecting ends or ends mitered to the fill slope (no headwall) may be used at select locations. d. Pipes 48 inches or greater in diameter shall require concrete headwalls to anchor and protect them.
ADT > 1500	<ul style="list-style-type: none"> a. Use flared end sections or safety end sections on: <ul style="list-style-type: none"> 1. Inlet ends of all storm drain pipes smaller than 48-inch diameter. 2. Outlet ends of all storm drain pipes smaller than 48-inch diameter on a 10% or less grade. 3. Inlet and outlet ends of all side drain pipes. 4. Outlet ends of 18-inch diameter and smaller slope drain pipes. b. Use concrete headwalls on: <ul style="list-style-type: none"> 1. Inlet and outlet ends of all 48-inch diameter storm drain pipes. 2. Outlet ends of all storm drain pipes over 10% grade. 3. An outlet headwall should be used for velocities greater than or equal to 12 ft/s.

8.2.13 Box Culverts

Box culverts will have a minimum size of 4 ft x 4 ft.

Box culverts will not be used for drainage areas greater than 20 square miles.

Box culverts are to be used only at sites that have favorable floodplain conditions, which include a well-defined creek channel and a site that is not likely to accumulate silt in the culvert barrels.

Multiple-barrel culverts shall fit within the natural dominant channel with only minor widening of the channel permissible in order to avoid conveyance loss through sediment deposit in some of the barrels.

8.2.14 Bottomless Culverts

Bottomless culverts are to be used in locations where it is necessary to maintain the natural streambed through the culvert to meet environmental regulatory requirements.

The footings for a bottomless culvert shall be placed below the streambed elevation on scour resistant material. The culvert foundations shall be placed deep enough to withstand the possible channel migration and scour. Due to the potential for scour problems at these sites, a scour analysis shall be performed for all bottomless culverts.

The following are possible alternates to using a bottomless culvert:

- Construct an embedded box culvert as described in section 8.2.6.
- Build a small bridge at the site

8.2.15 Fall

When a culvert is depressed below the streambed at the inlet, the depression is called the Fall. This depression is used to exert more head on the throat section for a given headwater elevation. A hydrodynamic improvement is made to the culvert performance by providing a more efficient control inlet section, which is the throat of the Fall.

For culverts without tapered inlets, the Fall is defined as the depth from the natural stream bed at the face to the inlet invert. For culverts with tapered inlets, the Fall is defined as the depth from the natural stream bed at the face to the throat invert. When Fall is used, a note should be placed on the plans so that the contractor will build it below the natural ground. For information concerning the design of an improved end treatment, see HDS 5.

8.2.16 Acceptable Culvert Design Methods

For economic considerations, the designer should strive to select the smallest size culvert that can handle the required design flow and meet the allowable headwater depth. There may be other environmental constraints such as AOP that requires the structure to be much larger than the normal culvert hydraulics require.

Culverts can be sized using the Federal Highway Administration's (FHWA) HY-8 computer model, the culvert design method given in section 8.3 or a computer program that employs the method defined in FHWA HDS 5. [\(8-7\)](#)

If the tailwater at the culvert site is affected by downstream controls such as natural stream constrictions, irregular downstream cross sections, obstructions, impoundments, or backwater from another stream or body of water, the tailwater elevation to be used in HY-8 shall first be determined by performing a backwater analysis using a HEC-RAS water surface profile computer model. See section 8.2.4 for additional information on tailwater.

8.2.17 Hydraulic Reports

Culverts that meet any of the conditions given in section 12.3.5 of this manual will require that a hydraulic study be completed and submitted with the PFPR request for review. For hydraulic study guidelines, see chapter 12 sections 12.3.5, 12.3.6, and 12.3.7 of this manual.

Culvert extensions that meet the following criteria will require a hydraulic analysis but not a detailed hydraulic study, as noted above in chapter 12:

1. Existing culvert barrels are extended by less than 50% of the original length.
2. Profile grade of the roadway is not being raised.
3. No existing scour or flooding problems and the potential for any significant problem is low.

Note: For GDOT projects designed in districts that involve FEMA, or require a backwater analysis to be performed, the hydraulic study shall be performed by the district or their assigned consultants. If the hydraulic study is done by the District, guidance and review is available if necessary on a case by case basis by the Hydraulics Group in the Office of Design Policy and Support.

8.2.18 Culverts Located Within a FEMA Regulatory Floodway

If the culvert is located within a FEMA regulatory floodway, **FEMA guidelines must also be satisfied**. See chapters 2 and 12 of this manual for more information on FEMA regulations and hydraulic modeling.

8.3 Typical Information Needed for Design

Design data that is required for culvert design includes, but is not limited to, the following:

Drainage Area	Roadway Data
Design Flow	Culvert Data
Headwater Depth	Stream Data
Tailwater	Survey Data

Appendix F of this manual includes a checklist for design data documentation required for the design of culverts. With regard to the survey data requirements listed above, see the drainage section of GDOT's Survey Manual [\(8-5\)](#) located here:

<http://www.dot.ga.gov/PartnerSmart/DesignManuals/SurveyManual/SurveyManual.pdf>.

8.4 Culvert Design Approach

Culvert flow may be nonuniform, gradually and rapidly varying, steady, or unsteady. A comprehensive analysis for these various flow scenarios would be time consuming and difficult. However, the FHWA has developed a design method that is straightforward and relatively easy to implement; the method involves evaluating different types of flow control for the culvert and designing based on the control that reflects the "minimum performance" or least efficient flow condition. For more detail relating to this design procedure and how it was developed, see HDS 5. [\(8-7\)](#)

Using this design approach, flow through culverts has been classified on the basis of where the control section is located. A control section is a location where there is a unique relationship between the flow rate and the upstream water surface elevation. Many different flow conditions exist over time, but at a given time the flow is either governed by the inlet geometry (inlet control); or by a combination of the culvert inlet configuration, the characteristics of the barrel, and the tailwater (outlet control). Control may oscillate from inlet to outlet. That is, while the culvert may

operate more efficiently at times (i.e., more flow for a given headwater level), it will never operate at a lower level of performance than calculated.

Design charts and nomographs that have been developed from hydraulic tests and theoretical calculations are provided for culvert design. Computer programs such as HY-8, provided by the FHWA, have also been developed for culvert design and are available for download (<http://www.fhwa.dot.gov/engineering/hydraulics/software/hy8/>).

8.4.1 Types of Control

As previously stated, culverts may operate in either inlet or outlet control. Table 8.4 shows the factors that must be considered in culvert design for inlet and outlet control.

For inlet control, only the inlet area, the edge configuration, and the shape influence the culvert performance for a given headwater elevation. The headwater elevation is calculated with respect to the inlet invert, and the tailwater elevation has no influence on performance.

For outlet control, all of the factors listed in Table 8.4 affect culvert performance. Headwater elevation is calculated with respect to the outlet invert, and the difference between headwater and tailwater elevation represents the energy that carries the flow through the culvert.

Table 8.4 Factors influencing culvert performance ⁽⁸⁻⁷⁾		
Factor	Inlet Control	Outlet Control
Headwater	X	X
Area	X	X
Shape	X	X
Inlet Configuration	X	X
Barrel Roughness		X
Barrel Length		X
Barrel Slope	X	X
Tailwater Elevation		X

Inlet Control

A culvert flowing in inlet control has shallow, high velocity flow categorized as supercritical. For supercritical flow, the control section is at the upstream end of the barrel (the inlet).

Figure 8.3 shows several different examples of inlet control flow. The type of flow depends on the submergence of the inlet and outlet ends of the culvert. In all of these examples, the control section

is at the inlet end of the culvert. Depending on the tailwater, a hydraulic jump may occur downstream of the inlet. Supercritical flow occurs in all of the barrels.

Figure 8.3 - Types of inlet control [\(8-7\)](#)

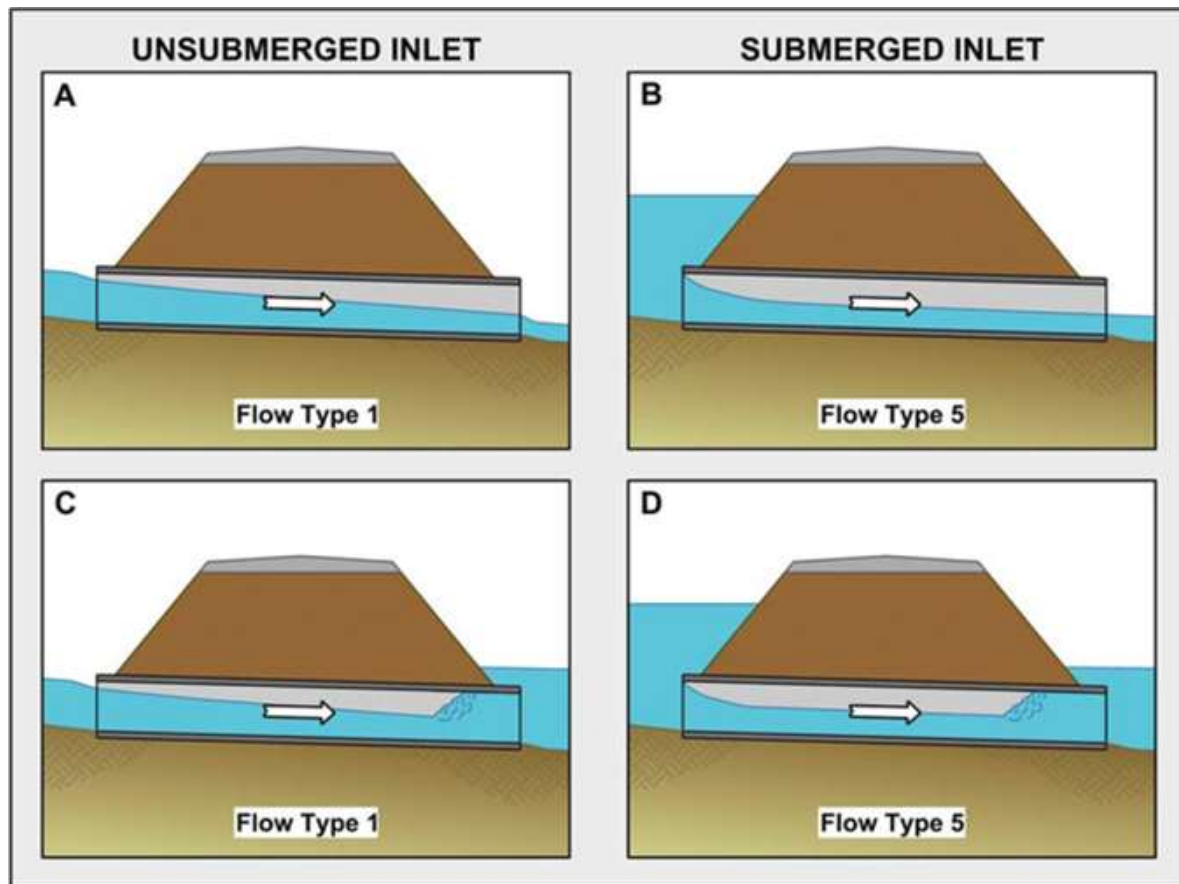

Culvert Factors Influencing Inlet Control

The following factors influence culverts operating in inlet control: [\(8-7\)](#)

- **Headwater** depth is measured from the invert of the inlet control section to the surface of the upstream pool.
- **Inlet area** is the cross-sectional area of the face of the culvert. Generally, the inlet face area is the same as the barrel area, but for tapered inlets the face area is enlarged, and the control section is at the throat.
- **Inlet edge configuration** describes the entrance type. Some typical inlet edge configurations are thin edge projecting, mitered, square edges in a headwall, and beveled edge.
- **Inlet shape** is usually the same as the shape of the culvert barrel; however, it may be enlarged as in the case of a tapered inlet. Typical shapes are rectangular, circular, and elliptical. Whenever the inlet face is a different size or shape than the culvert barrel, the possibility of an additional control section within the barrel exists.

- **Barrel Slope** influences inlet control performance, but the effect is small. Inlet control nomographs assume a slope of 2% for the slope correction term ($0.5S$ for most inlet types). This results in lowering the headwater required by $.01D$. In the computer program HY-8, the actual slope is used as a variable in the calculation.

Hydraulics of Inlet Control Culverts

Inlet control performance is defined by the three regions of flow, two of which are shown in Figure 8.3:

- Unsubmerged
- Transition
- Submerged

For low headwater conditions, as shown in Figure 8.3-A and Figure 8.3-C, the entrance of the culvert operates as a weir. A weir is an unsubmerged flow control section where the upstream water surface elevation can be predicted for a given flow rate.

For headwaters submerging the culvert entrance, as are shown in Figure 8.3-B and Figure 8.3-D, the entrance of the culvert operates as an orifice. An orifice is an opening, submerged on the upstream side, and flowing freely on the downstream side which functions as a control section. The flow transition zone between the low headwater (weir control) and the high headwater flow conditions (orifice control) is poorly defined as shown in Figure 8.4.

Headwater for inlet control can be determined using the inlet control nomographs found in HDS 5⁽⁸⁻⁷⁾ for each type of culvert.

The type of inlet will affect the operation of a culvert when operating in inlet and outlet control. However, since the inlet is controlling the capacity of a culvert operating in inlet control (supercritical flow occurs in the barrel), the culvert entrance may be modified to improve the culvert performance. As noted in Table 8.3, the four factors that affect culvert performance in inlet control are inlet edge condition, area, shape, and headwater. By making small modifications to these four factors, the capacity of a culvert may be increased dramatically. Culverts with these improvements are sometimes referred to as improved inlets.

Figure 8.4 - Inlet control curves

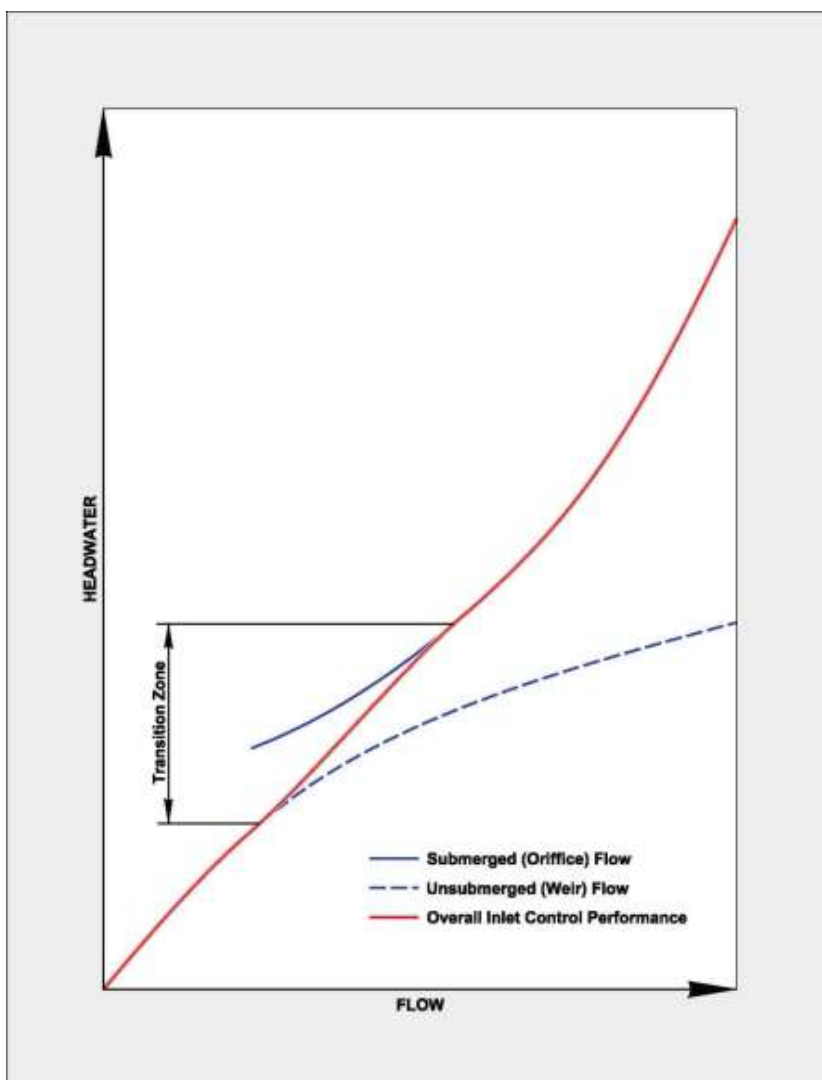

Improved End Treatments for Inlets

All culverts operating in inlet control should be evaluated for improvements that consist of the following:

- Beveled-edged inlets
- Side-tapered inlets
- Slope-tapered inlets

Improved end treatments with an enlarged face, by means of a depression (Fall), create more head on the barrel or throat for a given headwater elevation. This causes culvert performance to increase. For further information regarding the design of improved end treatments, see HDS 5. [\(8-7\)](#) See section 8.5.2 for dimensional limitations for improved inlets.

Outlet Control

A culvert flowing in outlet control will have relatively deep, low-velocity flow, termed subcritical flow or will be flowing full. For both subcritical flow and full barrel flow, the control is at the downstream end of the culvert (the outlet). In outlet control, the culvert barrel is not capable of conveying as much flow as the inlet opening will accept. The control section for outlet control is located at the barrel exit or further downstream. All the geometric and hydraulic characteristics of the culvert listed in Table 8.3 play a role in determining culvert capacity.

Figure 8.5 shows various culverts operating in outlet control. In all cases, the culvert is either flowing in subcritical flow or flowing full, and the control section is at the outlet of the culvert.

All of the factors influencing the performance of a culvert in inlet control also influence culverts in outlet control. In addition, the barrel characteristics (roughness, area, shape, length, and slope) and the tailwater elevation affect culvert performance in outlet control (Table 8.3).

Figure 8.5 - Types of outlet control [\(8-7\)](#)

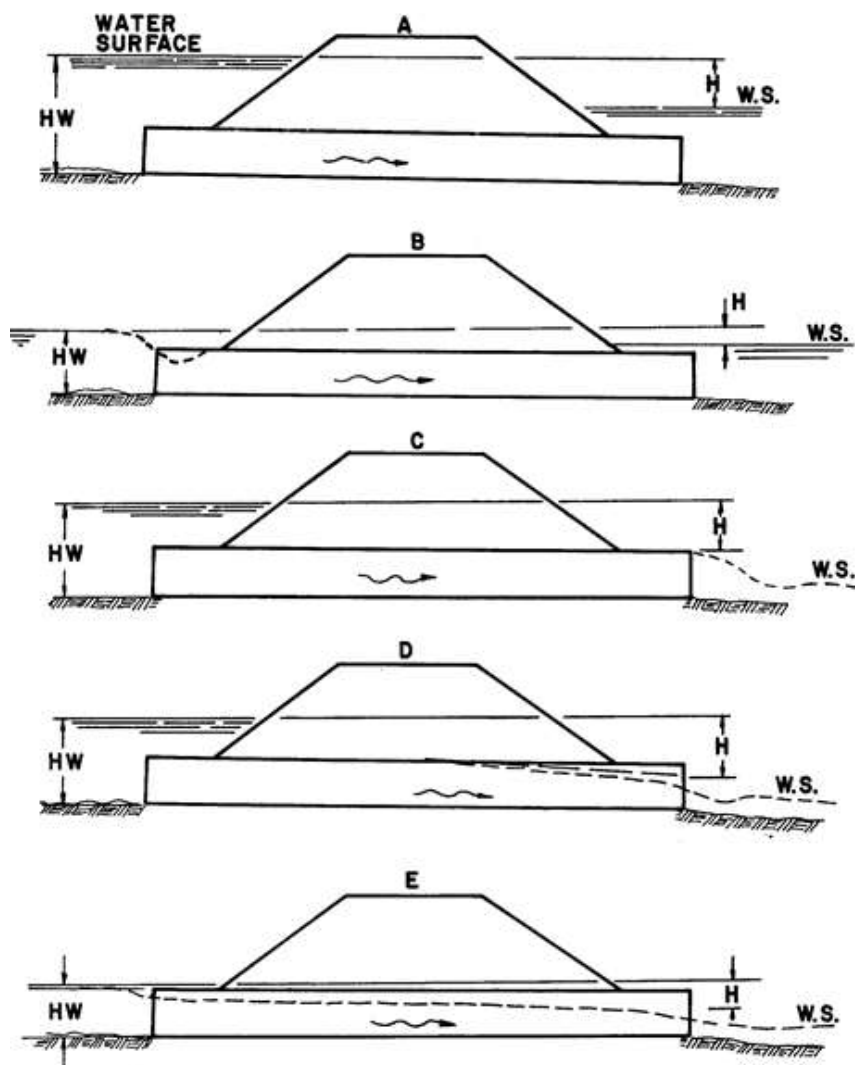

Culvert Factors Influencing Outlet Control

- **Barrel roughness** is a function of the material used to fabricate the barrel. Typical materials include concrete and corrugated metal. The roughness is represented by a hydraulic roughness coefficient such as the Manning's n value.
- **Barrel area** is a function of the culvert dimensions. A larger barrel area will convey more flow.
- **Barrel shape** is function of culvert type and material. Based on the location of the center of gravity for a given area, a box is the most efficient barrel shape. The arch and the circle are examples of additional, but less efficient, shapes.
- **Barrel length** is the total culvert length from the entrance to the exit of the culvert. Because the design height of the barrel and the slope influence the actual length, an approximation of barrel length is usually necessary to begin the design process.
- **Barrel slope** is the actual slope of the culvert barrel. The barrel slope is often the same as the natural stream slope. However, when the culvert inlet is raised or lowered, the barrel slope is different from the stream slope.
- **Tailwater elevation** is based on the downstream water surface elevation. Backwater calculations from a downstream control, a normal depth approximation, or field observations are used to define the tailwater elevation.

Hydraulics of Outlet Control Culverts

Full flow in the culvert barrel, as depicted in Figure 8.5-A, is the most applicable type of flow for describing outlet control hydraulics.

Outlet control flow conditions can be calculated based on energy balance. The total energy (H_L) required to pass the flow through the culvert barrel is made up of the following:

- Entrance loss (H_e)
- Friction losses through the barrel (H_f)
- Exit loss (H_o)

Other losses, including bend losses (H_b), losses at junctions (H_j), and losses at grates (H_g) should be included as appropriate (see chapter 5 of HDS 5 [\(8-7\)](#) for additional discussion of the bend and grate losses).

Entrance losses are a function of the velocity head in the barrel, and can be expressed as a coefficient times the velocity head.

$$H_e = k_e \left(\frac{V^2}{2g} \right) \quad (8.1)$$

Values of k_e based on various inlet configurations are given in Table 8.5.

Table 8.5 Entrance loss coefficients ⁽⁸⁻⁷⁾

Type of Structure and Design of Entrance	Coefficient K_e
Pipe Concrete	
<ul style="list-style-type: none"> • Projecting from fill, socket end (groove-end) 0.2 • Projecting from fill, sq. cut end 0.5 • Headwall or headwall and wingwalls <ul style="list-style-type: none"> ○ Socket end of pipe (groove-end) 0.2 ○ Square-edge 0.5 ○ Rounded (radius = D/12) 0.2 • Mitered to conform to fill slope 0.7 • *End section conforming to fill slope 0.5 • Beveled edges, 33.7° or 45° bevels 0.2 • Side- or slope-tapered inlet 0.2 	
Pipe or Pipe-Arch, Corrugated Metal	
<ul style="list-style-type: none"> • Projecting from fill (no headwall) 0.9 • Headwall or headwall and wingwalls square-edge 0.5 • Mitered to conform to fill slope, paved or unpaved slope 0.7 • *End section conforming to fill slope 0.5 • Beveled edges, 33.7° or 45° bevels 0.2 • Side- or slope-tapered inlet 0.2 	
Box, Reinforced Concrete	
<ul style="list-style-type: none"> • Headwall parallel to embankment (no wingwalls) <ul style="list-style-type: none"> ○ Square-edged on 3 edges 0.5 ○ Rounded on 3 edges to radius of D/12 or B/12 or beveled edges on 3 sides 0.2 • Wingwalls at 30° to 75° to barrel <ul style="list-style-type: none"> ○ Square-edged at crown 0.4 ○ Crown edge rounded to radius of D/12 or beveled top edge 0.2 • Wingwall at 10° to 25° to barrel <ul style="list-style-type: none"> ○ Square-edged at crown 0.5 • Wingwalls parallel (extension of sides) <ul style="list-style-type: none"> ○ Square-edged at crown 0.7 • Side- or slope-tapered inlet 0.2 	

***Note:** "End sections conforming to fill slope," made of either metal or concrete, are the sections commonly available from manufacturers. From limited hydraulic tests, these end sections are equivalent in operation to a headwall in inlet and outlet control. Some end sections, incorporating a closed taper in their design have a superior hydraulic performance. These latter sections can be designed using the information given for the beveled inlet.

The friction loss in the barrel (H_f) is also a function of the velocity head. Based on Manning's equation, the friction loss is:

$$H_f = \left[\frac{K_U n^2 L}{R^{1.33}} \right] \frac{V^2}{2g} \quad (8.2)$$

Where:

- $K_U = 29$
- $n =$ Manning's roughness coefficient
- $L =$ Length of the culvert barrel, ft
- $R =$ Hydraulic radius of the full culvert barrel = A/p , ft
- $A =$ Cross-sectional area of the barrel, ft^2
- $p =$ Perimeter of the barrel, ft
- $V =$ Velocity in the barrel, ft/s

The exit loss is a function of the change in velocity at the outlet of the culvert barrel. The downstream velocity is usually neglected, in which case the exit loss is equal to the full flow velocity head in the barrel as shown:

$$H_o = H_v = \frac{V^2}{2g} \quad (8.3)$$

By combining the sum of all losses, the Equation 8.4 for loss is obtained:

$$H_f = \left[\frac{K_U n^2 L}{R^{1.33}} \right] \frac{V^2}{2g} \quad (8.4)$$

It is important to note that the total available upstream energy (HW) includes the depth of the upstream water surface above the outlet invert and the approach velocity head. In most instances, the approach velocity is low, and the approach velocity head is neglected. However, it can be considered to be a part of the available headwater and used to convey the flow through the culvert.

Figure 8.6 - Headwater based on outlet control analysis

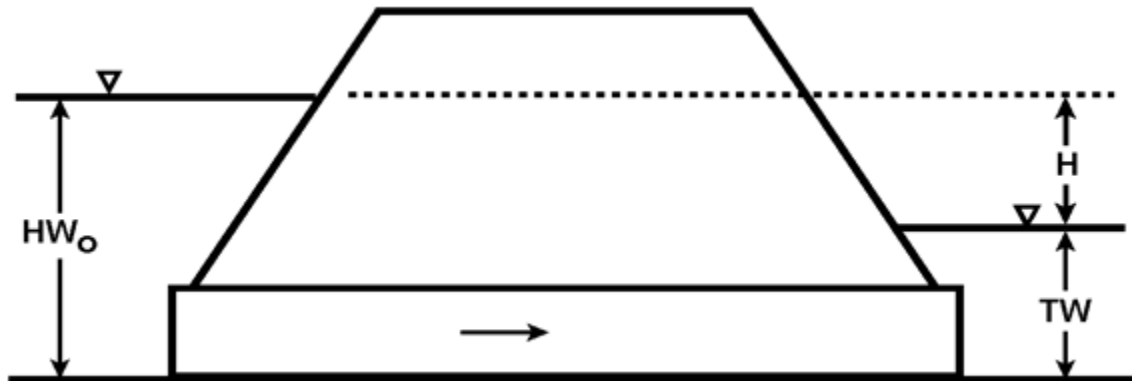

Likewise, the velocity downstream of the culvert (V_d) is usually neglected. When both approach and downstream velocities are neglected, the Equation 8.5 is found:

$$HW_o = TW + H \tag{8.5}$$

In this case, H is the difference in elevation between the water surface elevation at the outlet (tailwater elevation) and the water surface elevation at the inlet (headwater elevation) as shown in Figure 8.6.

Equations 8.1 through 8.5 were developed for full barrel flow, shown in Figure 8.5-A. The equations also apply to the flow situations shown in Figures 8.5-B and C, which are effectively full flow conditions. Backwater calculations may be required for the part-full flow conditions shown in Figures 8.5-D and E. These calculations begin at the water surface at the downstream end of the culvert and proceed upstream to the entrance of the culvert. The downstream water surface is based on critical depth at the culvert outlet or on the tailwater depth, whichever is higher.

Figure 8.7 - Hydraulic grade line approximation

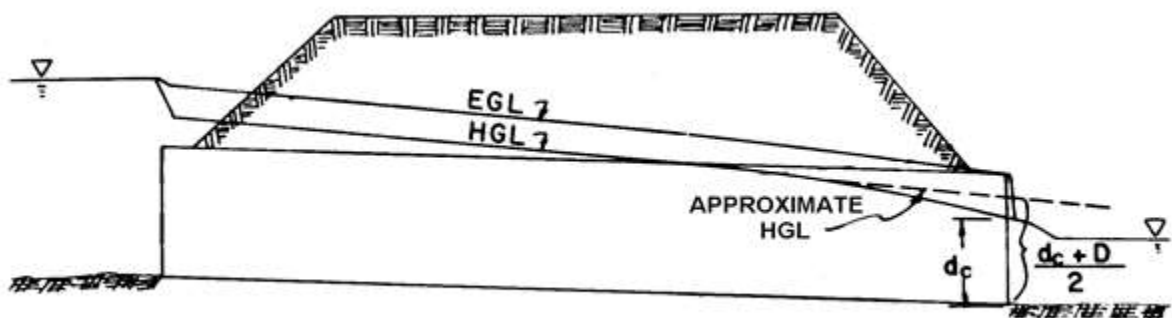

In order to avoid tedious backwater calculations, approximate methods have been developed to analyze part-full flow conditions. Based on numerous backwater calculations performed by the FHWA staff, it was found that a downstream extension of the full flow hydraulic grade line for the flow condition shown in Figure 8.7 pierces the plane of the culvert outlet at a point half-way between

critical depth and the top of the barrel. If the tailwater exceeds $(d_c+D)/2$, then the tailwater depth should be used to set the downstream end of the extended full flow hydraulic grade line.

This approximate method works best when the barrel flows full over at least part of its length (Figure 8.7). When the barrel is partly full over its entire length, the method becomes increasingly inaccurate as the headwater decreases further below the top of the barrel at the inlet. Adequate results are obtained down to a headwater of $0.75D$. For lower headwater depths, backwater calculations are required to obtain accurate headwater elevations.

The outlet control nomographs in HDS 5 (8-7) provide solutions for Equation 8.5 for entrance, friction, and exit losses in full-barrel flow. Using the approximate backwater method, the losses (H) obtained from the nomographs can be applied for the part-full flow conditions shown in Figure 8.8. The losses are added to the elevation of the extended full flow hydraulic grade line at the barrel outlet in order to obtain the headwater elevation. The extended hydraulic grade line is set at the higher of $(d_c+ D)/2$ or the tailwater elevation at the culvert outlet. This new term is identified as h_o . See equation 8.6. Again, the approximation works best when the barrel flows full over at least part of its length.

$$h_o = TW \text{ or } (d_c + D) / 2 \text{ whichever is greater} \tag{8.6}$$

When culverts are on a grade as shown in Figure 8.8, then Equation 8.6 becomes:

$$HW_o = h_o + H - LS \tag{8.7}$$

Remember, the elevation of the outlet control headwater is found from the following:

$$HW_o \text{ Elev} = EL_o + h_o + H \tag{8.8}$$

Figure 8.8 - Outlet control culvert on a grade

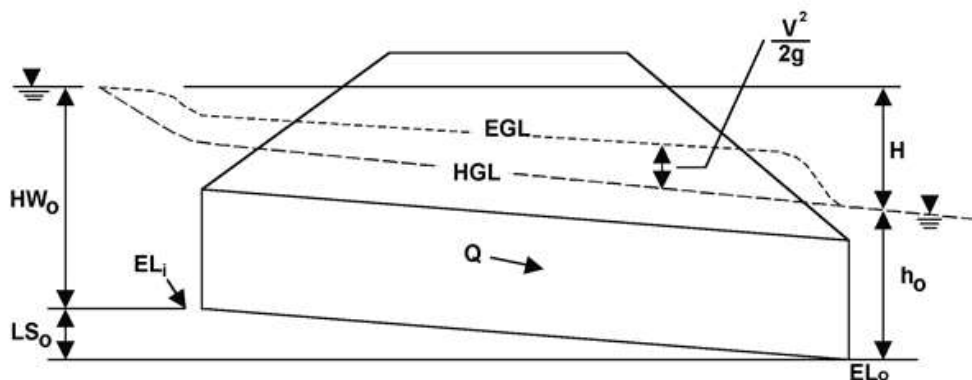

Outlet Velocity

Culvert outlet velocities should be calculated to determine the need for erosion protection at the culvert exit. Culverts usually result in outlet velocities which are higher than the natural stream velocities. These outlet velocities may require flow readjustment or energy dissipation to prevent downstream erosion. Photograph 8.3 illustrates high culvert outlet velocities discharging into a stream.

Photograph 8.3 - Outlet velocity



Inlet Control Outlet Velocity

In inlet control, backwater (also called drawdown) calculations may be necessary to determine the outlet velocity. These calculations begin at the culvert entrance and proceed downstream to the exit (HY-8 calculates outlet velocities using this procedure). The flow velocity is obtained from the flow and the cross-sectional area at the exit (Equation 8.2).

An approximation may be used to avoid backwater calculations in determining the outlet velocity for culverts operating in inlet control. The water surface profile converges toward normal depth as calculations proceed down the culvert barrel. Therefore, if the culvert is of adequate length, normal depth will exist at the culvert outlet. Even in short culverts, normal depth can be assumed and used to define the area of flow at the outlet and obtain the outlet velocity (Figure 8.9). The velocity calculated in this manner may be slightly higher than the actual velocity at the outlet. Normal depth in common culvert shapes may be calculated using a trial and error solution of Manning’s equation. The known inputs are flow rate, barrel resistance, slope, and geometry. Normal depths may also be obtained from design aids provided in publications such as HDS 3. [\(8-2\)](#)

Figure 8.9 - Inlet control outlet velocity

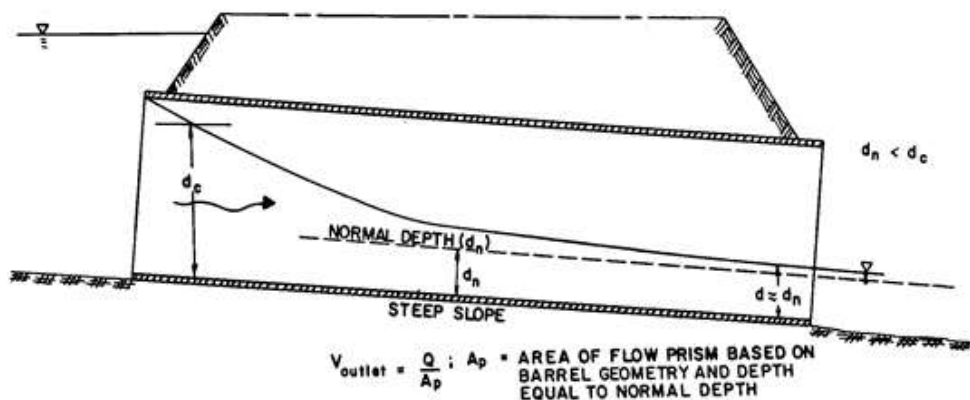

Outlet Control Outlet Velocity

In outlet control, the cross-sectional area of the flow is defined by the geometry of the outlet and either critical depth, tailwater depth, or the height of the conduit (Figure 8.10).

- Critical depth is used when the tailwater is less than the critical depth
- Tailwater depth is used when tailwater is greater than the critical depth, but below the top of the barrel
- Total barrel area is used when the tailwater exceeds the top of the barrel

Performance Curves

Performance curves are representations of flow rate versus headwater depth or elevation for a given flow. Due to the fact that a culvert has several possible control sections (inlet, outlet, and throat), a given installation will have a performance curve for each control section and one for roadway overtopping. The overall culvert performance curve is made up of the controlling portions of the individual performance curves for each control section. Figure 8.11 illustrates a performance curve for a culvert with roadway overtopping.

Figure 8.10 - Outlet control outlet velocity

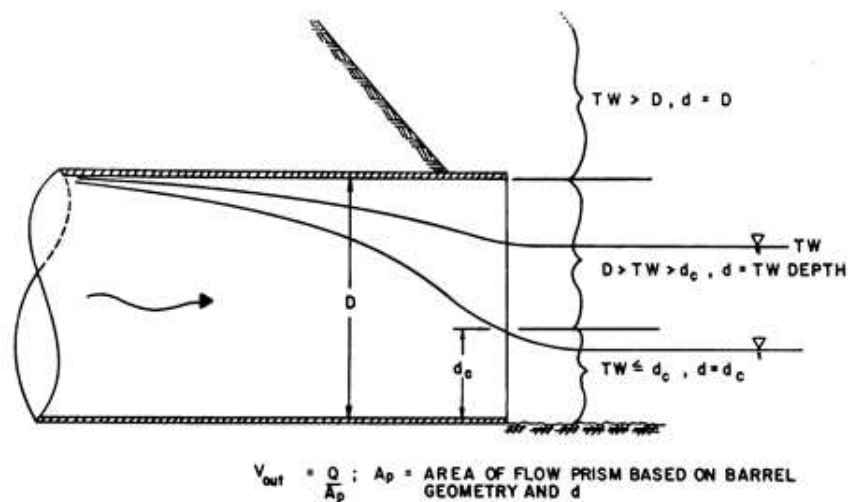

Using the combined culvert performance curve, the headwater elevation may be established for any flow rate or to visualize the performance of the culvert installation over a range of flow rates. When roadway overtopping begins, the rate of headwater increase will flatten severely. The headwater will continue to rise very slowly from that point.

Figure 8.11 - Culvert performance curve with roadway overtopping (8-7)

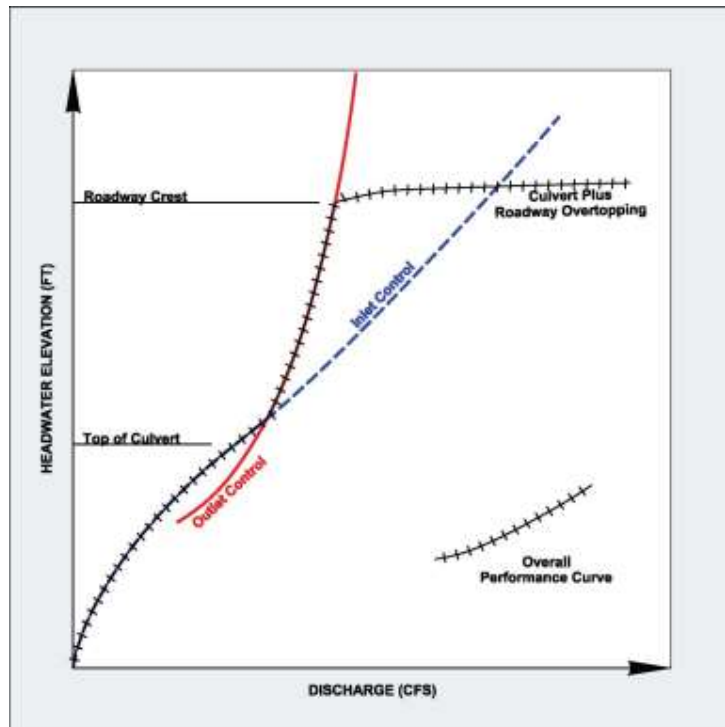

Since improved inlets have more than one possible control section, always develop a performance curve as shown in Figure 8.12 that summarizes the culvert performance. Remember that the throat control curve should always be controlling at the design discharge. See HDS 5 (8-7) for more information.

Figure 8.12 - Schematic of culvert performance curve with improved inlet

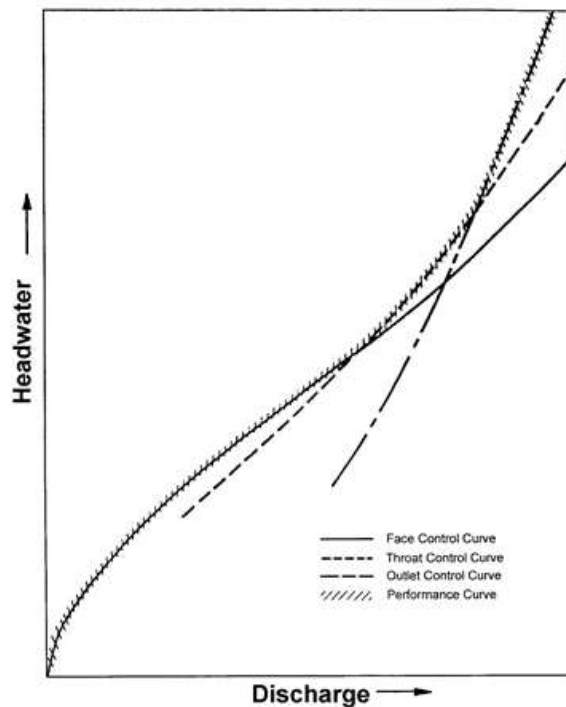

Constructing performance curves for culverts with tapered inlets helps to assure that the designer is aware of how the culvert will perform over a range of discharges. For high discharges, the outlet control curve may have a very steep slope which means that the headwater will increase rapidly with increasing discharge. Since there is a probability that the design discharge will be exceeded over the life of the culvert, the consequences of that event should be considered. This will help to evaluate the potential for damage to the roadway and to adjacent properties.

8.5 Culvert Design Method

The culvert design method presented here is a convenient and organized procedure for designing culverts, considering inlet and outlet control. While it is possible to follow the design method without an understanding of culvert hydraulics, this is not recommended. The result could be an inadequate and possibly unsafe structure.

8.5.1 Culvert Design Method

The culvert design form from HDS 5 (8-7) shown in Figure 8.13, has been formulated to guide the user through the design process. Summary blocks are provided at the top of the form for the project description, and the designer's identification. Summaries of hydrologic data are also included. At the top right, there is a small sketch of the culvert with blanks for inserting important dimensions and elevations.

Figure 8.13 - Culvert design form from HDS 5

PROJECT: _____		STATION: _____		CULVERT DESIGN FORM		
		SHEET _____ OF _____		DESIGNER / DATE: _____ / _____		
				REVIEWER / DATE: _____ / _____		
HYDROLOGICAL DATA			<p style="text-align: center;">ROADWAY ELEVATION: _____ ()</p> <p style="text-align: center;">EL_u: _____ ()</p> <p style="text-align: center;">EL_s: _____ () S_o: _____</p> <p style="text-align: center;">ORIGINAL STREAM BED</p> <p style="text-align: center;">EL_o: _____ ()</p> <p style="text-align: center;">S = S_o - T/L_o</p> <p style="text-align: center;">S = _____</p> <p style="text-align: center;">L_o = _____</p>			
See HDS 5-10 <input type="checkbox"/> METHOD: _____ <input type="checkbox"/> DRAINAGE AREA: _____ <input type="checkbox"/> STREAM SLOPE: _____ <input type="checkbox"/> CHANNEL SHAPE: _____ <input type="checkbox"/> ROUTING: _____ <input type="checkbox"/> OTHER: _____						
DESIGN FLOWS/TAIWATER						
R.I. (YEAR)	FLOW (cfs)	TW (ft)				
_____	_____	_____				
CULVERT DESCRIPTION:		HEADWATER CALCULATIONS				
MATERIAL - SHAPE - SIZE - ENTRANCE		Total Flow Q (cfs)	Flow Per Barrel Q/B (1)	INLET CONTROL		Outlet Headwater Elevation
				HW/D (2)	HW (3)	EL _u (4)
				TW (5)	d _o	(d _o + D) / 2 (6)
					h _o (6)	k _e (7)
					H (7)	EL _o (8)
						Outlet Velocity
						Comments
TECHNICAL FOOTNOTES:						
(1) USE Q/B FOR BOX CULVERTS		(4) EL _u = HW + EL _o (VERT OF INLET CONTROL SECTION)		(6) h _o = TW or (d _o + D) / 2 (WHICHEVER IS GREATER)		
(2) HW / D = HW / D OR HW _o / D FROM DESIGN CHARTS		(5) TW BASED ON DOWN STREAM CONTROL OR FLOW DEPTH IN CHANNEL		(7) H = [1 + k _e + (K _o n ² L) / R ^{1.48}] v ² / 2g WHERE K _o = 19.63 (29 IN ENGLISH UNITS)		
(3) T = HW - (EL _u - EL _o) T IS ZERO FOR CULVERTS ON GRADE				(8) EL _o = EL _u + H + h _o		
SUBSCRIPT DEFINITIONS:		COMMENTS / DISCUSSION:		CULVERT BARREL SELECTED:		
a. APPROXIMATE f. CULVERT FACE h _o . ALLOWABLE HEADWATER h _i . HEADWATER IN INLET CONTROL h _o . HEADWATER IN OUTLET CONTROL i. INLET CONTROL SECTION o. OUTLET s _o . STREAMBED AT CULVERT FACE tw. TAILWATER				SIZE: _____ SHAPE: _____ MATERIAL: _____ n _____ ENTRANCE: _____		

The central portion of the design form contains lines for inserting the trial culvert description and calculating the inlet control and outlet control headwater elevations. Space is provided at the lower center for comments and at the lower right for a description of the culvert selected.

The first step in the design process is to summarize all known data for the culvert at the top of the culvert design form. This information will have been collected or calculated prior to performing the actual culvert design. The next step is to select a preliminary culvert material, shape, size, and entrance type. The user then enters the design flow rate and proceeds with the inlet control calculations. For additional information on completing the culvert design form, see HDS 5. [\(8-7\)](#)

8.5.2 Inlet Control Calculations

Conventional Culverts - Inlet Control Design Method

The inlet control calculations determine the headwater elevation required to pass the design flow through the selected culvert configuration in inlet control. The approach velocity head may be included as part of the headwater, if desired. The inlet control nomographs in FHWA’s HDS 5 are used in the design process. For the following discussion, refer to the schematic inlet control nomograph shown in Figure 8.14

Figure 8.14 - Schematic of inlet control nomograph

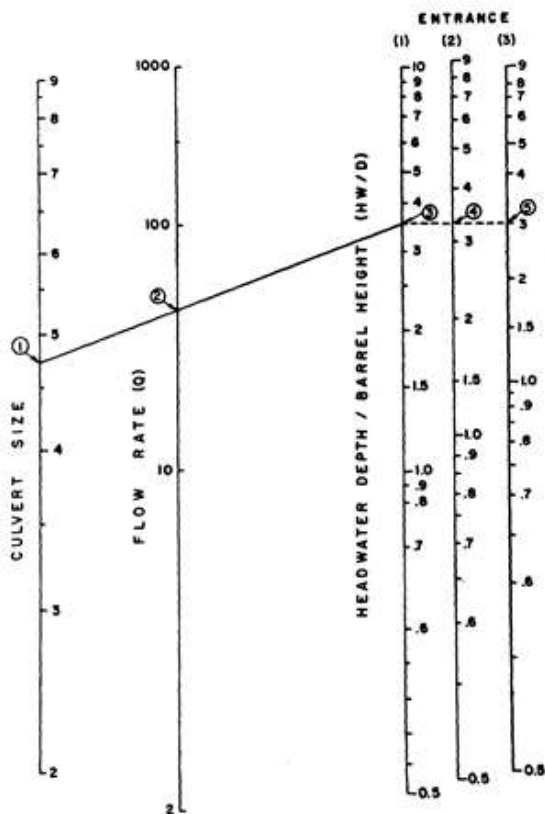

- Locate the selected culvert size (point 1) and flow rate (point 2) on the appropriate scales of the inlet control nomograph. (Note that for box culverts, the flow rate per foot of barrel width is used.)

- Using a straight edge, carefully extend a straight line from the culvert size (point 1) through the flow rate (point 2) and mark a point on the first headwater/culvert height (HW/D) scale (point 3). The first HW/D scale is also a turning line.
- If another HW/D scale is required, extend a horizontal line from the first HW/D scale (the turning line) to the desired scale and read the result.
- Multiply HW/D by the culvert height, D, to obtain the required headwater (HW) from the invert of the control section to the energy grade line. If the approach velocity is neglected, HW equals the required headwater depth (HW_i). If the approach velocity is included in the calculations, deduct the approach velocity head from HW to determine HW_i.
- Calculate the required depression (Fall, or “T” as used in the culvert design form in Figure 8.13) of the inlet control section below the stream bed as follows:

$$HW_d = ELh_d - ELs_f \quad (8.9)$$

$$Fall = HW_i - HW_d \quad (8.10)$$

Where:

- HW_a = Design headwater depth, ft
- ELh_d = Design headwater elevation, ft
- ELs_f = Elevation of the streambed at the face, ft
- HW_i = Required headwater depth, ft

Possible results and consequences of this calculation are:

1. If the Fall is negative or zero, set Fall equal to zero and proceed to “step f.”
2. If the Fall is positive, the inlet control section invert must be depressed below the streambed at the face by that amount. If the Fall is acceptable, proceed to “step f.”
3. If the Fall is positive and greater than an acceptable value, select another culvert configuration and begin again at “step a.”

Calculate the inlet control section invert elevation as follows:

$$EL_i = ELs_f - Fall$$

Where:

- EL_i = Invert elevation at the face of a culvert (EL_f) or at the throat of a culvert with a tapered inlet (EL_t)

Improved Inlets - Design Methods

Tapered inlet design begins with the selection of the culvert barrel size, shape, and material. These calculations are performed using the culvert design form shown in Figure 8.13. The tapered-inlet design calculation form (Figure 8.15) and the design nomographs contained in FHWA’s HDS 5 are used to design the tapered inlet. The result will be one or more culvert designs, with and without

tapered inlets, all of which meet the site design criteria. The designer must select the best design for the site under consideration.

In the design of tapered inlets, the goal is to maintain control at the efficient throat section in the design range of headwater and discharge. This is because the throat section has the same geometry as the barrel, and the barrel is the most costly part of the culvert. The inlet face is then sized large enough to pass the design flow without acting as a control section in the design discharge range. Some slight oversizing of the face is beneficial because the cost of constructing the tapered inlet is usually minor compared with the cost of the barrel.

The required size of the face can be reduced by use of favorable edge configurations such as beveled edges on the face section. Design nomographs are provided for favorable and less favorable edge conditions.

The following steps outline the design process for culverts with tapered inlets. Steps 1 and 2 are the same for all culverts with and without tapered inlets.

1. **Preliminary Culvert Sizing:** Estimate the culvert barrel size to begin calculations.
2. **Culvert Barrel Design:** Complete the culvert design form (Figure 8.13). These calculations yield the required Fall at the culvert entrance. For the inlet control calculations, the appropriate inlet control nomograph is used for the tapered inlet throat. The required Fall is upstream of the inlet face section for side-tapered inlets and is between the face section and throat section for slope-tapered inlets. The culvert design form should be completed for all barrels of interest. Plot outlet control performance curves for the barrels of interest. Plot inlet control performance curves for the faces of culverts with non-enlarged inlets and for the throats of tapered inlets.
3. **Tapered Inlet Design:** Use the tapered inlet design form (Figure 8.15) for selecting the type of tapered inlet to be used and determining its dimensions.

Figure 8.15 - Tapered inlet design form

PROJECT: _____		STATION: _____		TAPERED INLET DESIGN FORM																							
SHEET _____ OF _____		DESIGNER / DATE: _____ / _____		REVIEWER / DATE: _____ / _____																							
DESIGN DATA: Q = _____ () ; EL _{th} = _____ () EL THROAT INVERT = _____ () EL STREAM BED AT FACE = _____ () T = _____ TAPER = _____ : 1 (4:1 TO 6:1) STREAM SLOPE, S ₀ = _____ () / () SLOPE OF BARREL, S = _____ () / () S ₀ = _____ : 1 (2:1 TO 3:1) BARREL SHAPE AND MATERIAL: _____ N = _____ B = _____ D = _____ INLET EDGE DESCRIPTION _____		<p style="text-align: center;">ELEVATION Side-taper</p>		<p style="text-align: center;">ELEVATION Slope-taper</p>		COMMENTS _____ _____																					
Q ()	EL _h ()	EL Throat Invert	EL Face Invert (1)	HW (2)	HW E (3)	Q B ₁ (4)	MIN B ₁ (5)	Selected B ₁	SLOPE-TAPERED ONLY				SIDE-TAPERED w/ depression														
									MIN L ₁ (6)	L ₂ (7)	Check L ₂ (8)	Adj. L ₂ (9)	Adj. Taper (10)	L ₁ (11)	EL Crest Iny. (12)	HW ₀ (12)	MIN W (13)										
(1) SIDE-TAPERED : EL FACE INVERT = EL THROAT INVERT + 1 FT (0.3 M APPROX) SLOPE-TAPERED : EL FACE INVERT = EL STREAM BED AT FACE		(2) HW ₀ = EL _h - EL FACE INVERT		(3) 1.1 D ≥ E ≥ D; E = D FOR BOX CULVERTS		(4) FROM DESIGN CHARTS		(5) MIN B ₁ = Q / (Q / B ₁)		(6) MIN L ₁ = 0.5 NB		(7) L ₁ = (EL FACE INVERT - EL THROAT INVERT) / S ₀		(8) CHECK L ₂ = $\left[\frac{B_1 - NB}{2} \right] \cdot \text{TAPER} - L_1$		(9) IF (8) > (7), ADJ. L ₂ = $\frac{B_1 - NB}{2}$, TAPER = L ₂		(10) IF (7) > (9), ADJ. TAPER = $(L_2 + L_1) / \left[\frac{B_1 - NB}{2} \right]$		(11) SIDE-TAPERED : L = $\left[\frac{B_1 - NB}{2} \right] \cdot \text{TAPER}$		SLOPE-TAPERED : L = L ₁ + L ₂		(12) HW ₀ = EL _h - EL CREST INVERT		(13) MIN W = K ₀ Q / HW ₀ ^{1.75} Where K ₀ = 0.35 (0.64 SI)	
SELECTED DESIGN B ₁ _____ L ₁ _____ L ₂ _____ L ₀ _____ BEVELS ANGLE _____ b = _____ () ; d = _____ () TAPER = _____ : 1 S ₀ = _____ : 1																											

To use the tapered inlet design form (Figure 8.15), perform the following steps:

- a. **Complete Design Data.** Fill in the required design data on the top of the form.
 1. Flow, Q, is the selected design flow rate, from the culvert design form, Figure 8.13.
 2. EL_h is the inlet control headwater elevation.
 3. The elevation of the throat invert (EL_t) is the inlet invert elevation (EL_i).
 4. The elevation of the stream bed at the face (EL_s), the stream slope (S₀), and the slope of the barrel (S).
 5. The Fall is the difference between the streambed elevation at the face and the throat invert elevation.
 6. Select a side taper (TAPER) between 4:1 and 6:1 and a Fall slope (S_f) between 1V:2H and 1V:3H. The TAPER may be modified during the calculations.
 7. Enter the barrel shape and material, the size, and the inlet edge configuration. Note that for tapered inlets, the inlet edge configuration is designated the "tapered inlet throat."

b. **Calculate the Face Width.**

1. Enter the flow rate, the inlet control headwater elevation (EL_{hi}), and the throat invert elevation on the design forms. (For the slope-tapered inlet with mitered face, the face section is downstream of the crest. Calculate the vertical difference between the stream bed at the crest and the face invert (y), which includes part of the total inlet Fall.
2. Perform the calculations resulting in the face width (B_f). Face control design nomographs are contained in FHWA's HDS 5.

Note: When designing side-or slope-tapered inlets for box culverts with double barrels, the required face width derived from the design procedures is the total clear width of the face. The thickness of the center wall must be added to this clear width to obtain the total face width. No design procedures are available for tapered inlets on box culverts with more than two barrels.

c. **Calculate Tapered-Inlet Dimensions.** If the Fall is less than $D/4$ ($D/2$ for a slope-tapered inlet with a mitered face), a side-tapered inlet must be used. Otherwise, either a side-tapered inlet with a depression upstream of the face or a slope-tapered inlet may be used.

1. For a slope-tapered inlet with a vertical face, calculate L_2 , L_3 , and the TAPER. (For the slope-tapered inlet with a mitered face, calculate the horizontal distance between the crest and the face section invert L_4 . These dimensions are shown on the small sketches in the top center of the forms).
2. Calculate the overall tapered inlet length, L_1 .
3. For a side-tapered inlet, check to assure that the Fall between the face section and the throat section is one foot or less. If not, return to step b. with a revised face invert elevation.

d. **Calculate the Minimum Crest Width.** For a side-tapered inlet with Fall upstream of the face, calculate the minimum crest width and check it against the proposed crest width. In order to obtain the necessary crest length for a depressed side-tapered inlet, it may be necessary to increase the flare angle of the wingwalls for the type of depression or to increase the length of crest on the sump for the design. It is important to note that the TAPER must be greater than 4:1.

e. **Fit the Design into the Embankment Section.** Using a sketch based on the derived dimensions and a sketch of the roadway section to the same scale, design a culvert that fits the site. Adjust inlet dimensions as necessary but do not reduce dimensions below the minimum requirements of the design form.

f. **Prepare Performance Curves.** Using additional flow rate values and the appropriate nomographs, calculate a performance curve for the selected face section. Do not adjust inlet dimensions at this step in the design process. Plot the face control performance curve on the same sheet as the throat control and the outlet control performance curves.

g. **Enter Design Dimensions.** If the design is satisfactory, enter the dimensions at the lower right of the design form. Otherwise, calculate another alternative design by returning to step 3a.

Dimensional Limitations for Improved Inlets

The following dimensional limitations must be observed when designing tapered inlets using the design charts of this publication. Tapered inlets can only be used where the culvert width is less than three times its height, ($B < 3 D$).

a. Side-Tapered Inlets.

1. $4:1 \leq \text{TAPER} \leq 6:1$

Tapers less divergent than 6:1 may be used but performance will be underestimated.

2. Wingwall flare angle range from 15 degrees to 26 degrees with top edge beveled or from 26 degrees to 90 degrees with or without bevels (Figure 8.16).
3. If a Fall is used upstream of the face, extend the barrel invert slope upstream from the face a distance of $D/2$ before sloping upward more steeply. The maximum vertical slope of the apron is: 1V:2H.
4. $D \leq E \leq 1.1D$

b. Slope-tapered Inlets.

1. $4:1 \leq \text{TAPER} < 6:1$
(Tapers $> 6:1$ may be used, but performance will be underestimated.)
2. $1V:3H \geq S_f \geq 1V:2H$
If $S_f > 1V:3H$, use side-tapered design.
3. Minimum $L_3 = 0.5B$
4. $D/4 \leq \text{Fall} \leq 1.5D$
 - i. For $\text{Fall} < D/4$, use side-tapered design
 - ii. For $\text{Fall} < D/2$, do not use the slope-tapered inlet with a mitered face
 - iii. For $\text{Fall} > 1.5D$, estimate friction losses between the face and the throat by using Equation 8.11 and add the additional losses to HW_t .

$$H_1 = \left[\frac{K_U n^2 L_i}{R^{1.33}} \right] \frac{Q^2}{2gA^2} \quad (8.11)$$

Where:

- $K_U = 29$
- $H_1 =$ Friction head loss in the tapered inlet (ft)
- $n =$ Manning's n for the tapered inlet material
- $L_i =$ Length of the tapered inlet (ft)
- $R =$ Average hydraulic radius of the tapered inlet = $(A_f + A_t)/(P_f + P_t)$ (ft)
- $Q =$ Flow rate (ft^3/s)

$g =$ Gravitational acceleration (ft/s/s)

$A =$ Average cross sectional area of the tapered inlet – $(A_f + A_t)/2$ (ft²)

5. Wingwall flare angles range from 15 degrees to 26 degrees with the top edge beveled or from 26 degrees to 90 degrees with or without bevels (Figure 8.16).

Figure 8.16 - Inlet edge conditions for rectangular tapered inlets

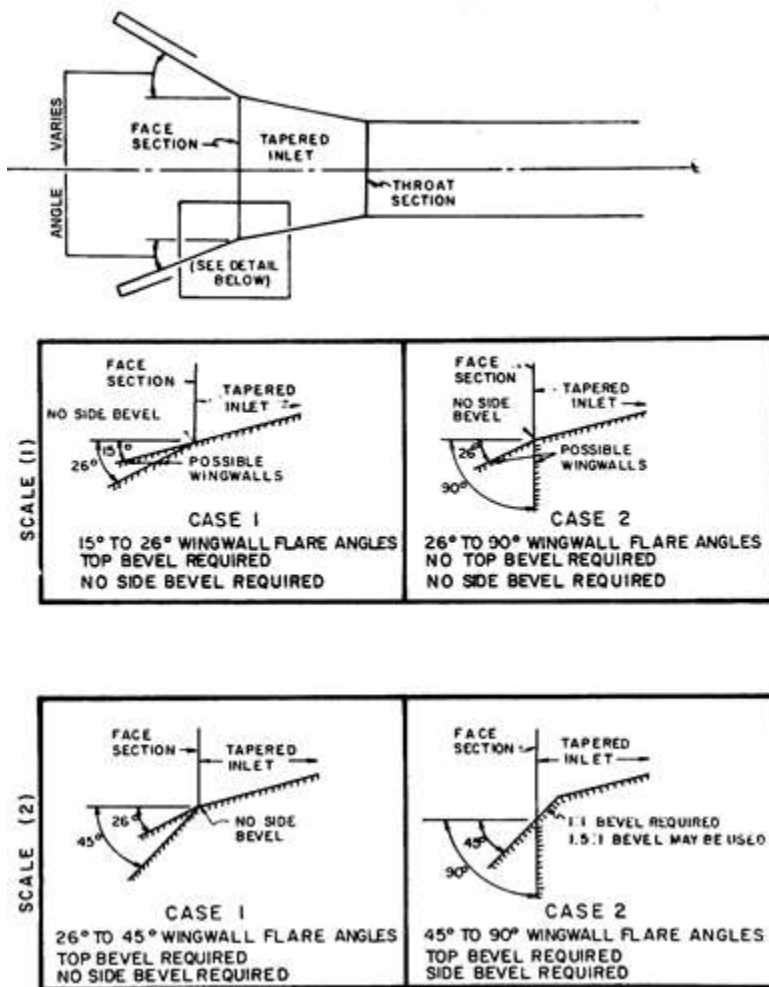

8.5.3 Outlet Control Calculations

The outlet control calculations result in the headwater elevation required to convey the design discharge through the selected culvert in outlet control. The approach and downstream velocities may be included in the design process, if desired. The critical depth charts and outlet control nomographs in FHWA’s HDS 5 are used in the design process. For illustration, refer to the schematic critical depth chart and outlet control nomograph shown in Figures 8.17 and 8.18, respectively.

- Determine the tailwater depth above the outlet invert (TW) at the design flow rate. This is obtained from backwater or normal depth calculations, or from field observations.

- Using Figure 8.17 find the critical depth (d_c) by using the flow rate. Note: d_c cannot exceed D .

Note: The d_c curves are truncated for convenience when they converge. If an accurate d_c is required for $d_c > 0.9D$ consult a hydraulics handbook such as HDS 5. [\(8-7\)](#)

Figure 8.17 - Schematic of critical depth chart

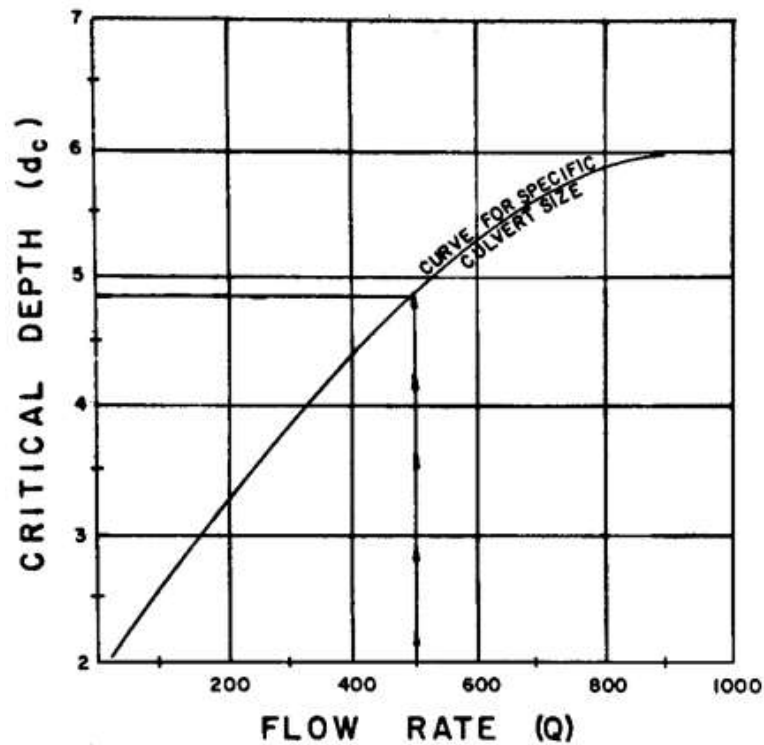
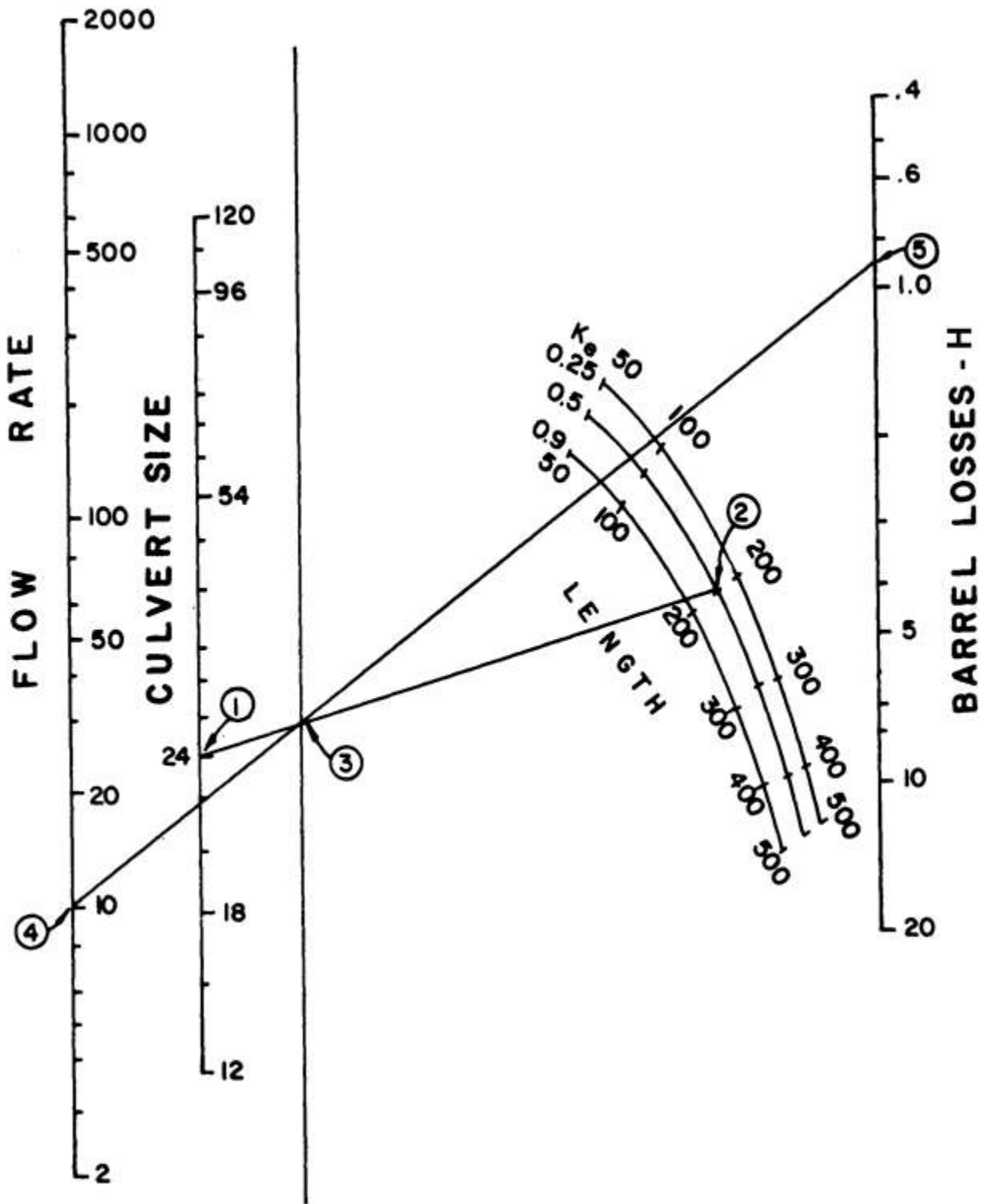

Figure 8.18 - Schematic of outlet control nomograph



- Calculate $(d_c + D)/2$.
- Determine the depth from the culvert outlet invert to the hydraulic grade line (h_o),
- $h_o = TW$ or $(d_e + D)/2$ whichever is larger.
- From Table 8.5, obtain the appropriate entrance loss coefficient, k_e , for the culvert inlet configuration.
- Determine the losses through the culvert barrel, H , using the outlet control nomograph (Figure 8.18) or Equation 8.5 if outside the range of the nomograph.

Using a straight edge, connect the culvert size (point 1) with the culvert length on the appropriate k_e scale (point 2). This defines a point on the turning line (point 3).

Again using the straight edge, extend a line from the discharge (point 4) through the point on the turning line (point 3) to the head loss (H) scale. Read H . H is the energy loss through the culvert, including entrance, friction, and outlet losses.

Note: Careful alignment of the straightedge is necessary to obtain good results from the outlet control nomograph.

- Calculate the required outlet control headwater elevation. Using Equation 8.12.

$$EL_{h_o} = EL_o + H + h_o \quad (8.12)$$

where EL_o is the invert elevation at the outlet.

- If the outlet control headwater elevation exceeds the design headwater elevation, a new culvert configuration must be selected and the process repeated. Generally, an enlarged barrel will be necessary since inlet improvements provide limited benefit in outlet control.

8.5.4 Evaluation of Results

Compare the headwater elevations calculated for inlet and outlet control. The higher of the two is designated the controlling headwater elevation. The culvert can be expected to operate with the higher headwater for at least part of the time.

Special culvert installations such as culverts with safety grates, junctions, or bends are discussed in HDS 5, [\(8-7\)](#) as well as unusual culvert configurations such as "broken-back" culverts, siphons, and low head installations.

Copies of the FHWA's culvert design forms are provided in [Appendix E](#) of this manual to aid the designer. These forms provide a convenient and organized way of keeping track of culvert design data and have been formulated to guide the designer through the design process.

8.5.5 Energy Dissipation

Erosion at culvert outlets is a common problem. Determination of the flow condition, scour potential, and channel erodibility should be standard procedure in the design of all highway culverts. Ultimately, the only safe procedure is to design on the basis that erosion at a culvert outlet and downstream channel will occur, and must be protected against. See FHWA publication HEC 14

Hydraulic Design of Energy Dissipators for Culverts and Channels (8-9) and policies within this chapter for energy dissipation design guidance.

General Guidelines for Energy Dissipators

Energy dissipators should be considered for the following conditions:

- The potential erosion at the culvert outlet will become a risk to the roadway itself or a downstream property.
- Culvert outlet velocities are greater than 15 ft/s.

When considering energy dissipators for culvert outlets, determine if the native bed material is erodible. It should be noted that energy dissipators may not always be necessary. Conditions such as bedrock-lined stream channels or steep stream slope may not require energy dissipation design.

General Design Procedure

The following method is intended to show the designer a general workflow process for a manual method of designing energy dissipators:

1. Locate the culvert's design data including survey information, design storm frequency, and all other pertinent hydraulic information (i.e., channel slope, culvert type, size, shape.)
2. Determine if an energy dissipator is warranted based on the previous section, *General Guideline for Energy Dissipators*.
3. Choose appropriate dissipator design options and begin designing each alternative.
4. Select the alternative that best fits the intended site while considering effectiveness and construction cost.
5. If a riprap apron is required, design the apron according to the guidelines in chapter 9.
6. Document all design, structural, and buoyancy calculations.

8.5.6 Culvert Outlet Velocity and Velocity Modification

The continuity equation (Equation 4.11) can be used in all situations to compute culvert outlet velocity, either within the barrel or at the outlet. Given the design discharge, the designer should determine the flow area, which is a function of the type of control (outlet or inlet).

Culvert outlet velocity is one of the primary indicators of erosion potential. Outlet velocities are seldom less than 10 ft/s and may reach 30 ft/s or more for culverts on steep slopes. If the velocity is higher than the velocity in the downstream channel, measures to modify or reduce velocity within the culvert barrel should be considered. However, the degree of velocity reduction is typically limited and must be balanced against the increased costs involved.

8.5.7 Outlet Velocity Considerations for Culverts on Mild Slopes

For culverts on mild slopes operating under outlet control with high tailwater depths (Figures 8.5a and 8.5b), the outlet velocity will be determined using the full area of the barrel. With this condition, it is possible to reduce the velocity by increasing the culvert size. Note that with high tailwater

conditions, erosion may not be a serious problem since the ponded water will act as an energy dissipator; however, it will be important to determine if tailwater will always control, or if any of the other conditions shown on Figure 8.5 might occur.

When the discharge is high enough to produce a critical depth equal to the crown of the culvert barrel (Figure 8.5c), full flow will again occur and the outlet velocity will be based on the area of the barrel. As before, the barrel size can be increased to achieve a reduction in velocity, but it will be necessary to evaluate if the increased size results in a flow depth below the crown, indicating less than full flow at the outlet. When this occurs, the area used in the continuity equation should be based on the actual flow area.

When culverts discharge with the critical depth occurring near the outlet (Figures 8.5d and 8.5e), increasing the barrel size will typically not significantly reduce the outlet velocity. Similarly, increasing the resistance factor will not affect outlet velocity since critical depth is not a function of n .

8.5.8 Outlet Velocity Considerations for Culverts on Steep Slopes

For culverts flowing on steep slopes with no tailwater (Figures 8.3a and 8.3c) the outlet velocity can be determined from normal depth calculations. With normal depth conditions on a steep slope, increasing the barrel size may slightly decrease the outlet velocity; however, calculations show that in reality, the slope is the driving force in establishing the normal depth. The velocity will not be significantly altered by doubling the culvert size/width. Thus, such an approach may not be cost effective. Some reduction in outlet velocity can be obtained by increasing the number of barrels, but this is also generally not cost effective.

Increasing the barrel resistance can significantly reduce outlet velocity and is an important factor in velocity reduction for culverts on steep slopes. The objective is to force full flow conditions near the outlet without creating additional headwater. HEC 14 discusses various methods of creating additional roughness (from changing pipe material to baffles and roughness rings) and details the appropriate design procedures.

8.5.9 Types of Energy Dissipation

Different stormwater outlets often require different methods of energy dissipation. This section of the chapter identifies alternate options for energy dissipators and provides a discussion on when they are warranted.

8.5.9.1 Hydraulic Jump Energy Dissipators

The hydraulic jump is a natural phenomenon which occurs when supercritical flow changes to subcritical flow (see chapter 4 of this manual). This abrupt change in flow condition is accomplished by considerable turbulence and loss of energy, making the hydraulic jump an effective energy dissipation device. To better define the location and length of a hydraulic jump, standard design structures have been developed to force the hydraulic jump to occur. These structures typically use blocks, sills, or other roughness elements to impose exaggerated resistance to flow. Forced hydraulic jump structures applicable in highway engineering include the Colorado State University (CSU) rigid boundary basin, US Bureau of Reclamation (USBR) type IV basin, and the St. Anthony Falls (SAF) basin.

The CSU rigid boundary basin was developed from model study tests of basins with abrupt expansions (Figure 8.19a and b); however, the configuration recommended for use is a combination flared-abrupt, expansion basin. The roughness elements are symmetrical about the basin centerline, and the spacing between the elements is approximately equal to the element width. Alternate rows of roughness elements are staggered. Riprap may be needed for a short distance downstream of the basin.

Figure 8.19a (left) - Schematic of CSU rigid

Figure 8.19b (right) - Photo of CSU rigid boundary basin

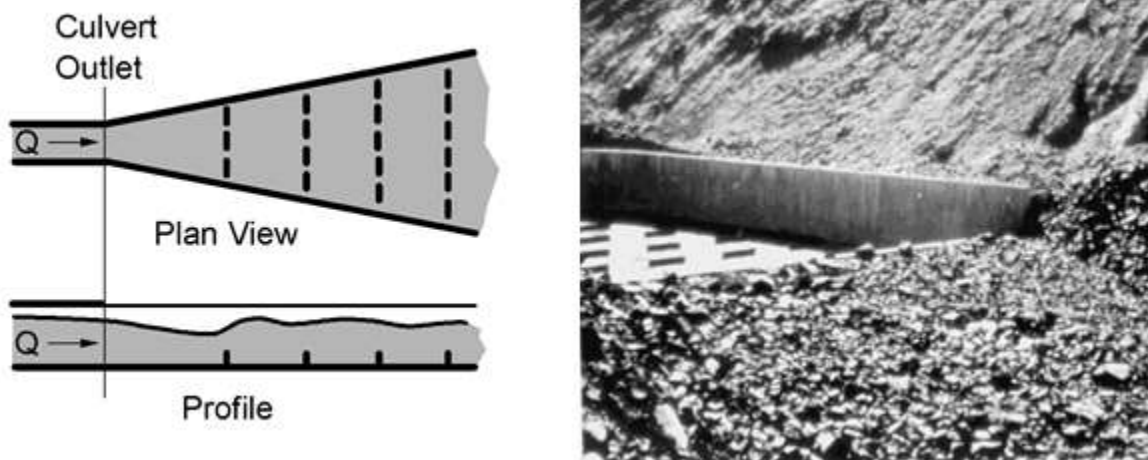

The SAF stilling basin is a more generalized design that uses special appurtenances, chute blocks and baffle or floor blocks to force the hydraulic jump to occur (Figure 8.20a and b). It is recommended for Froude numbers between 1.7 and 17. Similar to the CSU basin, the design criteria were developed from model study test results.

Figure 8.20a (left) - Schematic of SAF stilling basin

Figure 8.20b (right) - Photo of SAF stilling basin



8.5.9.2 Impact Basins

As the name implies, impact basins are designed with part of the structure physically blocking the free discharge of water. Water impacting on the basin structure dissipates energy and modifies the

downstream flow regime. Several types of impact basins include the Contra Costa Energy Dissipator, Hook type energy dissipator, and the USBR Type VI Stilling Basin.

The USBR Type VI impact basin is most commonly used in highway engineering (Figure 8.21a and b). The structure is contained in a relatively small box-like structure which requires no tailwater for successful performance. The shape of the basin evolved from extensive tests, and resulted in a design based around a vertical hanging baffle. Energy dissipation is initiated by flow striking the vertical hanging baffle and being deflected upstream by the horizontal portion of the baffle and by the floor, creating horizontal eddies. Notches in the baffle provide a self-cleaning feature after prolonged nonuse of the structure. If the basin is full of sediment, the notches provide concentrated jets of water for cleaning. If the basin is completely clogged, the full discharge can be carried over the top of the baffle. Use of the basin is limited to installations where the velocity at the entrance of the basin does not exceed 50 ft/s and discharge is less than 400 ft³/s.

Figure 8.21a (left) - Schematic of USBR

Figure 8.21b (right) - Photo of Baffle-wall energy dissipator - USBR Type VI

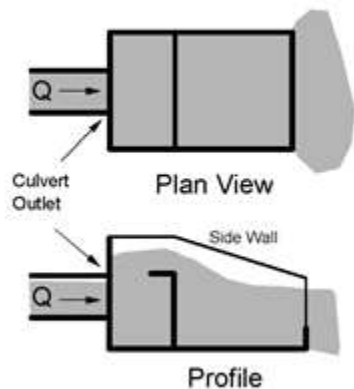

8.5.9.3 Drop Structures With Energy Dissipation

Drop structures are commonly used for flow control and energy dissipation. Reducing channel slope by placing drop structures at intervals along the channel changes a continuous steeper sloped channel into a series of milder sloped reaches with vertical drops. Instead of slowing down and transferring high erosion producing velocities into lower non-erosive velocities, drop structures control the slope of the channel so that high velocities never develop. The kinetic energy or velocity gained by the water as it drops over the crest of each structure is dissipated by specially designed aprons or stilling basins.

Energy dissipation occurs through the impact of the falling water on the floor, redirection of the flow, and turbulence. The stilling basin used to dissipate excess energy can vary from a simple concrete apron to an apron with flow obstructions such as baffle blocks, sills, or abrupt rises. The length of the concrete apron required can be shortened by addition of these appurtenances. Figure 8.22 illustrates a straight drop stilling basin with floor blocks and an end sill. The design of this and other drop structure stilling basins is detailed in HEC 14. [\(8-9\)](#)

Figure 8.22 - Straight drop spillway stilling basin



8.5.9.4 Stilling Wells

Stilling wells dissipate kinetic energy by forcing flow to travel vertically upward to reach the downstream channel. The stilling well most commonly used in highway engineering is the USACE Stilling Well (Figure 8.23 a and b). Apply a stilling well where debris is not a serious problem. It will operate with moderate to high concentrations of sand and silt, but is not recommended for areas where quantities of large floating or rolling debris are expected unless suitable debris-control structures are used. Its greatest application in highway engineering is at the outlets of storm drains and pipe down drains where little debris is expected. It is recommended that riprap or other types of channel protection be provided around the stilling well outlet.

Figure 8.23a (left) - Schematic of USACE
Figure 8.23b (right) - Photo of USACE stilling well



8.5.9.5 Riprap Stilling Basins

Riprap stilling basins are commonly used at culvert outlets (Figure 8.24). The design procedure for riprap energy dissipators was developed from model study tests. The results of this testing indicated that the size of the scour hole at the outlet of a culvert was related to the size of the riprap, discharge, brink depth and tailwater depth. The mound of rock material that often forms on the bed downstream of the scour hole contributes to dissipation of energy and reduction of the scour hole size. The general design guidelines for riprap stilling basins include preshaping the scour hole and

lining it with riprap. Specific design criteria for the length, depth and width of the scour hole, and the entire basin, are provided in HEC 14. [\(8-9\)](#)

Figure 8.24 - Riprapped culvert energy basin



8.6 Design Software

Specific design software is not mandated by the Department; however, culvert analysis programs should use HY-8 as the basis of their analysis. This section provides some general information on the use of HY-8.

8.6.1 Culvert Design Using HY-8

Culvert design and energy dissipator design for culvert outlets can be completed with HY-8. The energy dissipation design is based on FHWA publication HEC 14. [\(8-9\)](#) Table 8.6 provides guidelines for the use of various energy dissipators described in HEC 14. A performance curve is necessary for any energy dissipator design and analysis

Table 8.6 Energy Dissipator Limitations
(source Table XII-1, HEC 14 ⁽⁸⁻⁹⁾)

Dissipator Type	Froude Number Fr	Allowable Debris			Tailwater TW	Special Consideration
		Silt Sand	Boulders	Floating		
Free Hydraulic Jump	>1	H	H	H	Required	--
						--
CSU Rigid Boundary	<3	M	L	M	--	--
Tumbling Flow	>1	M	L	L	--	4<S _o <25
Increased Resistance	--	M	L	L	--	Check Outlet Control HW
USBR Type II	4 to 14	M	L	M	Required	--
USBR Type III	4.5 to 17	M	L	M	Required	--
USBR Type IV	2.5 to 4.5	M	L	M	Required	--
SAF	1.7 to 17	M	L	M	Required	--
Contra Costa	<3	H	M	M	<0.5D	--
Hook	1.8 to 3	H	M	M	--	--
USBR Type VI	--	M	L	L	Desirable	Q<400 ft ³ /s, V<50 ft/s
Forest Service	--	M	L	L	Desirable	D<36 inch
Drop Structure	<1	H	L	M	Required	Drop< 15 ft
Manifold	--	M	N	N	Desirable	
USACE Stilling Well	--	M	L	N	Desirable	
Riprap	<3	H	H	H	--	

Note:

N = none
L = low
M = moderate
H = heavy

HY-8 is a menu-driven culvert design program developed by the FHWA. The program allows the user to interactively enter, save, and edit data. The HY-8 program will compute the culvert hydraulics for circular, rectangular, elliptical, arch, and user defined geometry. The output from the HY-8 program can be printed out and incorporated directly into a hydraulic report.

The logic behind the HY-8 program is similar to that used in the culvert design method. The program calculates and compares the headwater elevations for inlet and outlet control. The program then selects the higher of the two elevations as the control elevation. The program incorporates the effects of tailwater when calculating these elevations. If the controlling headwater elevation results in overtopping of the roadway embankment, the program performs an overtopping analysis whereby the flow is balanced between the culvert discharge and the surcharge over the roadway.

There are five main groups of data to be entered into the program, which allows the user to edit the group fields all within one dialogue box. These groups are:

1. The discharge data
2. The tailwater data
3. The roadway data
4. The culvert data
5. The site data

Chapter 8 References

1. American Association of State Highway and Transportation Officials (AASHTO). 2007. Highway Drainage Guidelines, 4th Ed.
2. Federal Highway Administration. 1961, Design Charts for Open-Channel Flow, [Hydraulic Design Series No. 3](#), FHWA-EPD-86-102. Federal Highway Administration (FHWA), U.S. Department of Transportation, Washington, D.C
3. Federal Highway Administration (FHWA), Federal-Aid Policy Guide. "Highways." [Title 23](#) Code of Federal Regulations (CFR).
4. Federal Highway Administration (FHWA) Offices of Bridge Technology and Technical Services, 2013. [HY-8](#), Culvert Analysis Computer Program (Version 7.3).
5. Georgia Department of Transportation (GDOT). 2013. [GDOT Survey Manual](#).
6. Kilgore, Roger T., Bergendahl, Bart S., Hotchkiss, Rollin H. Culvert Design for Aquatic Organism Passage, [Hydraulic Engineering Circular No. 26](#), First Edition. FHWA-HIF-11-008. Federal Highway Administration (FHWA), U.S. Department of Transportation, Washington, D.C.
7. Schall, James D., Thompson, Philip L., Zerges, Steve M., Kilgore, Roger T., Morris, Johnny L. 2012, Hydraulic Design of Highway Culverts Third Edition, [Hydraulic Design Series No. 5](#), FHWA-HIF-12-026. Federal Highway Administration (FHWA), U.S. Department of Transportation, Washington, D.C.
8. Stream-Simulation Group, United States Forest Service (USFS). 2008. [Stream Simulation: An Ecological Approach to Providing Passage for Aquatic Organisms at Road-Stream Crossings](#). 0877 1801P. San Dimas, CA: U.S. Department of Agriculture (USDA), Forest Service, San Dimas Technology and Development Center.
9. Thompson, P.L., Kilgore, R.T. 2006, Hydraulic Design of Energy Dissipators for Culverts and Channels, [Hydraulic Engineering Circular No. 14](#), FHWA-NHI-06-086. Federal Highway Administration (FHWA), U.S. Department of Transportation, Washington, D.C.
10. United States Army Corps of Engineers (USACE). 2012. Savannah District 2012 [Nationwide Permit Regional Conditions](#), USACE, 2012

Intentionally Left Blank

Chapter 9. Erosion and Sediment Control Guidelines - Contents

Chapter 9. Erosion and Sediment Control Guidelines - Contents.....9-i

9.1 Introduction.....9-1

9.2 NPDES Program9-1

9.3 Georgia NPDES General Permit Regulations and Requirements9-2

9.4 ESPCPs.....9-3

9.4.1 Introduction.....9-3

9.4.2 Policy Guidelines9-4

9.4.3 Description of the Complete ESPCP9-5

9.4.4 Signatory Requirements for ESPCPs.....9-7

9.4.5 Revisions to the ESPCP During the Life of a Project9-8

9.5 Right-of-Way.....9-8

9.6 BMP Location and Design Criteria9-8

Chapter 9 References.....9-10

Chapter 9. Erosion and Sediment Control Guidelines

9.1 Introduction

Stormwater runoff can be a major cause of impaired water quality in Georgia's streams, rivers, and lakes. Runoff from disturbed lands can degrade surface water by increasing the concentration of TSS, which also raises the turbidity. Since many pollutants have the tendency to adhere to solids, suspended solids in stormwater runoff can add significant quantities of nutrients, metals, and toxins. Making the problem worse, paved surfaces and storm sewer systems decrease the amount of runoff that can be absorbed into the ground, where stormwater would otherwise be filtered and detained. This chapter is concerned primarily with erosion and sedimentation control during the construction of roadway and facilities for GDOT. For control of other pollutants such as nutrients (e.g. nitrogen and phosphorus), dissolved and total metals (most commonly copper, lead, and zinc), and trash, the designer should refer to chapter 10 of this manual and also the GSMM.

Sedimentation problems are the result of inadequate erosion and sedimentation controls on construction sites. To prevent these problems, vegetative and structural BMPs control the erosion of soil and the resulting sedimentation. Proper BMP erosion and sediment management along with sampling turbidity levels of the construction site stormwater discharge can greatly reduce stormwater pollution from construction site activities. Turbidity, commonly measured in nephelometric turbidity units (NTU), is a measurement based on the amount of light scattered and absorbed by fine particles in suspension.

9.2 NPDES Program

NPDES permits are one of two types: an individual permit or a general permit. Individual permits are unique to each facility and are required for large MS4s. General permits prescribe one set of requirements for similar facilities that meet the eligibility criteria. Small MS4s and construction site activities, such as roadway projects, are normally covered by a general permit.

Applying for a general permit is accomplished by submitting a Notice of Intent (NOI) to the Georgia Environmental Protection Division (EPD). The NOI includes the location and description of the construction activity and defines the erosion, sedimentation, and pollution control plan (ESPCP) goals to minimize impacts with BMPs and monitoring. The NOI process is considerably less complicated than the application required for an individual permit.

Typically, ESPCPs for GDOT's construction projects should be in compliance with the State of Georgia NPDES General Permit, the *Manual for Erosion and Sediment Control in Georgia* (Green Book), [\(9-2\)](#) the Georgia Soil and Water Conservation Commission (GSWCC), GDOT's own guidelines, and all other applicable federal and state laws and rules. The designer should read and understand the applicable NPDES general permit and the Green Book prior to beginning the design of an ESPCP. Section 9.6 discusses common BMPs used for ESPCPs.

The linear nature of GDOT's projects creates some difficulty regarding the appropriate methods used to comply with the permit and the Green Book. The current edition of GDOT's *Plan Presentation Guide* (PPG) [\(9-1\)](#) gives the designer checklist-style guidance to overcome this difficulty by informing the designer how to prepare an effective and uniform ESPCP. The PPG explains what information to include in an ESPCP and how to present the information, but it does not address the

technical aspects of ESPCP design. This chapter is a technical resource for ESPCP design, provides clarification to the requirements of the NPDES general permit, and points to the guidance provided by the Green Book. It is assumed that the reader already has a good understanding of the general format of a complete ESPCP prepared by GDOT and that the reader is aware of the current EPD-GSWCC checklist, which is the checklist for ESPCP preparation effective on January 1 of the year in which the land-disturbing activity was permitted. The current checklist and an explanation of how to address the checklist are available on GDOT's website under ROADS/Design Policies and Guidelines (also accessible through the following web address):

<http://www.dot.ga.gov/PS/DesignManuals/DesignGuides>.

9.3 Georgia NPDES General Permit Regulations and Requirements

Copies of the current NPDES permits, the Green Book, and other related technical documents may be downloaded from the Georgia Soil and Water Conservation Commission's website, <http://gaswcc.georgia.gov/documents-list>.

The NPDES permitting authority in Georgia is the EPD. The EPD issues three general permits that authorize the discharge of stormwater from three distinct types of construction projects that disturb 1 or more acres of land. These three general permits, which are reissued every 5 years, are:

- **Stand-alone construction activity (GAR100001):** construction activities that are not part of a common development where the primary permittee chooses not to use secondary permittees.
- **Infrastructure construction sites (GAR100002):** construction activities that are not part of a common development that include the construction, installation, and maintenance of roadway and railway projects. These activities may also include all conduits, pipes, pipelines, substations, cables, wires, trenches, vaults, manholes, and other similar structures. Most all GDOT linear projects should be considered infrastructure construction sites.
- **Common development construction (GAR100003):** a contiguous area where multiple, separate, and distinct construction activities will be taking place at different times on different schedules under one plan.

Each of the permits is available on the EPD's website. Most GDOT-related projects fall under the general permit GAR100002. The major requirements of this permit are (also outlined in Figure 9.1):

- **Submission of an NOI** – A draft NOI is generally submitted by GDOT along with final plans, which is then completed by GDOT and given to EPD for review and comment. Two half-size ESPCP sets should be furnished for this submittal.
- **Preparation of an ESPCP** – The plan must detail the BMPs to be used at the site, and it must be prepared under the supervision of a GSWCC Level II Certified Design Professional whose professional license is issued by the State of Georgia in the field of: engineering, architecture, landscape architecture, forestry, geology, or land surveying; or a person that is a Certified Professional in Erosion and Sediment Control (CPESC) with a current certification by EnviroCert International, Inc. Design professionals shall practice in a manner that complies with applicable Georgia law governing professional licensure.

- **Implementation** – The plan must be implemented as designed.
- **Sampling** – For infrastructure projects, representative sampling may be utilized and is often performed. The permit requires that regulated sites be monitored by sampling the stormwater discharge quality with respect to turbidity.

Figure 9.1 - ESPCP flow chart

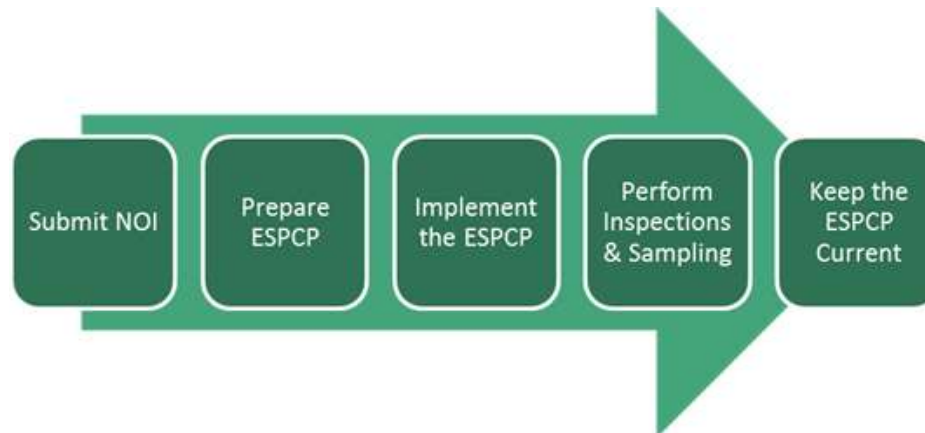

9.4 ESPCPs

9.4.1 Introduction

Preparation of the ESPCP requires an understanding of GDOT policy and appropriate construction general permit requirements. This section will discuss both the EPD-GSWCC requirements, as well as GDOT policy, to help guide the designer through plan production. Section 9.4.3 discusses in detail the submittal package that GDOT requires, but for any other information see the PPG [\(9-1\)](#) document.

The EPD-GSWCC checklist requires that all state waters within 200 feet and all ponds and lakes within 500 feet of the right-of-way be labeled on a *Drainage Area Map (53 Series)* and a *Watershed Map (55 Series)*. Additionally, these waterways should be shown on the BMP Location Detail Sheets (54 Series) if they are within the limits of the sheet, and they should be shown on the cover sheet if the scale allows. The plans should delineate all watersheds within the project limits. They should also show flow paths from the outfall discharge point to the receiving water. This is to assist personnel in identifying critical water features that can be affected by construction activities.

Where applicable, stream buffers for these streams must also be shown. All streams should be delineated by an ecologist and included in environmental documentation, including the Environmental Resource Impact Table (ERIT). Associated buffers that are on the right-of-way shall be described on the stream buffer table that is provided within the ESPCP General Notes Sheets. Georgia law restricts the amount and type of work that is permitted within the stream buffers, requiring the designer to describe the nature of work that is permitted within the buffer areas. Stream buffers begin at the point of wretched vegetation along the stream channel. Wretched vegetation is at the point of clear distinction between the flow of water and vegetation. This is caused by the normal movement of water where soil and vegetation are removed through naturally occurring erosion. The types of work qualifying for a buffer variance are listed in EPD Rule 391-3-7-

.05, Buffer Variance Procedures and Criteria. However, even with an EPD buffer variance, a Section 404 nationwide permit from the U.S. Army Corps of Engineers would be required.

Georgia law permits work to be performed inside buffers without a variance on projects for the construction and maintenance of bridges and roadway drainage structures. GDOT and EPD interpret this law to mean that any work within 50 feet of either side of a culvert or other drainage structure (see examples 6 and 8 in the ESA Examples.pdf document on the ROADS website: <http://www.dot.ga.gov/PartnerSmart/DesignManuals/ElectronicData/ESA%20Examples.pdf#search=ESA%20Examples%2Epdf>) and any work within 100 feet of either side of a bridge (see ESA examples 9 and 10) will not require a buffer variance, provided the work within the buffer is associated with the structure. Occasionally, instances may arise that require areas beyond the 50-foot and 100-foot limits to be disturbed to build the structure. If projects require this additional area to construct a bridge or drainage structure, permission to work beyond the 50-foot and 100-foot limits without a variance may be granted by EPD on a case-by-case basis. Representatives of GDOT should consult with EPD to determine whether or not a particular project may warrant a buffer variance exemption. Buffer variances must be approved prior to the ESPCP and NOI being submitted to EPD for review.

Although work within the permitted 50-foot and 100-foot limits does not require a buffer variance, the construction activities will impact the stream buffer, and the stream buffer encroachment table should indicate that the buffer is impacted. The designer must also assume that the contractor should clear all the area within the right-of-way. Any area within the right-of-way where clearing is not permitted (buffer areas beyond the 50-foot or 100-foot limits mentioned above, habitat of any threatened or endangered species located on the right-of-way, etc.) should be marked with an orange barrier fence. Where there are instances that the right-of-way is not entirely cleared but purchased for future work, a plan note should be added to the plans indicating the new clearing limits. The buffer areas that have restricted access and are left undisturbed act as a BMP and should be labeled with the standard "Bf" symbol. A buffer cannot be thinned or trimmed of vegetation and must remain for water quality and the preservation of aquatic habitat.

9.4.2 Policy Guidelines

The design of the ESPCP is site specific and design elements will vary. However, the following guidelines provide assistance in the preparation of ESPCPs:

- Use approved sources for the proper design and location of BMPs, spacing, and application.
- Keep runoff velocities low by using use check dams, J hooks, earthen berms, and/or diversion ditches, for example.
- Do not place silt control gates in perennial or intermittent streams.
- Do not place sediment basins, ditches, or other structures in wetland areas.
- Be certain that sufficient right-of-way is available for BMPs.

Show the following background data on all ESPCP sheets: centerline with stationing, all edges of pavement, the construction limits, the right-of-way, all easements, and the location of all drainage structures, pipes, streams, lakes, and wetlands.

For staged projects, the ESPCP should correspond to the staged construction plans (19 Series) provided in the plan submission package. In certain cases, additional sub-stages must be shown to indicate the installation of perimeter BMPs and sediment storage BMPs. The construction plans should depict the final post-construction BMPs, which include ditch linings, riprap, vegetated swales, and stabilized drainage structures. See chapter 10 of this manual for additional information on post-construction stormwater BMPs. The title block shall show the normal project information, have the large letters "ESPCP", and indicate the particular stage of construction as "Stage 1", "Stage 2", etc.

ESPCPs are required for all projects regardless of the size of the disturbed area. ESPCPs for haul roads, borrow pits, excess material pits, etc., shall be prepared by the contractor. These plans shall be prepared for all stages of construction and should include the appropriate items and quantities.

For projects with less than 1 acre of disturbed area, an abbreviated ESPCP may be prepared, and only the Erosion and Sediment Control Legend and Uniform Code Sheets, the BMP Location Details, and any applicable Erosion and Sediment Control Construction Detail Sheets are required. All projects with 1 or more disturbed acres must have a complete stand-alone ESPCP. Abbreviated ESPCPs and complete stand-alone ESPCPs are placed in the back of the construction plans.

The complete ESPCP must include:

- an ESPCP Cover Sheet (50 Series)
- ESPCP General Notes Sheets (typically 2 or 3 sheets, 51 Series)
- ESPCP Legend and Uniform Code Sheets (52 Series)
- a Drainage Area Map (53 Series)
- BMP Location Details (54 Series)
- a Watershed and Monitoring Site Location Map (typically a USGS topographical sheet, 55 Series)
- Construction Details and Standards (for erosion and sedimentation control items only, 56 Series)

GDOT requires a Worksite Erosion Control Supervisor (WECS) to be on call 24 hours a day for all construction projects. The role of the WECS is primarily to oversee all erosion and sedimentation control related work throughout the project. They perform daily inspections on ESPCP BMPs to check performance and make adjustments as needed to comply with permit and contract requirements. The WECS works closely with the Field Project Engineer to prevent violations and reduce BMP failures. For more information on the WECS program, see GDOT Special Provision 161 or the GDOT Local Technical Assistance Program (LTAP) Office:

<http://www.dot.ga.gov/PS/Local/LTAP>.

9.4.3 Description of the Complete ESPCP

If the ESPCP is prepared by GDOT, it must be signed and stamped by GDOT's Chief Engineer. If the ESPCP is prepared by a consultant, it must be signed and stamped by a GSWCC Level II Certified Design Professional. Although the ESPCP preparation for a GDOT infrastructure project is

discussed in detail in GDOT's PPG [\(9-1\)](#), a few important points are presented within this section. See section 9.4.4 of this chapter for additional information on signatory requirements.

A. BMP Location Detail Sheets:

BMP location detail sheets show the actual location of the BMPs for each stage of construction. These detail sheets should have the same drawing scale and orientation as the Construction Plan Sheets. Staged BMP installation must match the construction staging if the construction is staged. GAR100002 indicates that proposed contour lines and a BMP legend should be included on each BMP Location Detail Sheet. GDOT has found that adding these items to the BMP sheets causes confusion due to the excessive amount of line work. As a result, the BMP legend (54 Series) is placed directly in front of the BMP sheets, and the proposed contour lines are not shown on BMP sheets. The profile and cross-section views in the Construction Sheets provide information equivalent to proposed contour lines. However, existing contours should be shown during the Initial Phase to ensure adequate perimeter control and other initial BMPs. The direction of concentrated stormwater runoff should be shown with flow arrows. For plans that involve special grading (e.g., detention ponds or other post-construction stormwater design elements), proposed contour lines are shown on the BMP sheets for these areas.

On the BMP Location Detail sheets, show the information in the following bulleted list in bold format with the proper BMP symbol, line code and type for the item, as shown on the Erosion and Sediment Control Legend Uniform Code Sheet (see GDOT Construction Detail Sheets EC-L1 to EC-L6 for symbols, line codes, and patterns). When BMPs are shown as installed in later phases of construction, show those BMPs as faded, where retained. If any BMPs are no longer needed in later phases, the symbol and BMP should be removed.

All ditches that have protection of any type whether temporary or permanent must be shown with the width of the ditch and the depth of protection. The width and depth may be shown in tabular format, and can also be shown in the summary of quantities. Each type of ditch protection shall have a different code on the plan sheet.

- Perimeter silt fence Types NS (nonsensitive) and S (sensitive) as defined in the latest version of the [Manual for Erosion and Sediment Control in Georgia](#), as required. They have their own line codes and symbols, which must be shown.
- Indicate which type of silt control gate is being used.
- All temporary sediment basins and skimmers should have the appropriate symbols.
- Show riprap slope protection with the pattern symbol. Any other form of slope protection must be shown by its symbol and pattern.
- All down-drain structures, temporary or permanent, should be labeled with their symbols and line codes.
- Silt retention barrier as recommended by the soil's lab by the symbol and line code
- Storm-drain outlet protection by the symbol and pattern

B. Watershed and Monitoring Location Map (scale no less than 1 inch = 2,000 feet):

Use a USGS 7.5-minute quadrangle map as the base topographic map, unless contours from a more accurate source can cover the entire area. If a quadrangle map is used, show the name, date published, scale, north arrow, and the contour interval.

This map differs from the Drainage Area Map in that it is prepared to a much larger scale to show the big picture. The most important items to show on this map are the receiving water(s), the delineation of the receiving-water SWDA(s), and the turbidity sampling location(s).

A site may have multiple receiving waters, each having a distinct SWDA. Delineate each receiving-water SWDA and indicate its area in square miles. In addition, the total project size must also be noted.

Note that the NPDES permit states, "When the permittee has chosen to use a USGS topographic map and the receiving water(s) is not shown on the USGS topographic map, the location of the receiving water(s) must be hand-drawn on the USGS topographic from where the storm water(s) enters the receiving water(s) to the point where the receiving water(s) combines with the first blue line stream shown on the USGS topographic map."

C. ESPCP Construction Details and Standards:

Erosion and sediment control details and standard sheets are included as applicable and are obtained from GDOT's ROADS website.

9.4.4 Signatory Requirements for ESPCPs

The education and certification requirements for individuals qualified to sign ESPCPs are established by the Official Code of Georgia O.C.G.A. § 12-7-19, and are defined by the GSWCC in Section 600-8-1 of the *RULES OF THE STATE SOIL AND WATER CONSERVATION COMMISSION*. Signatory requirements for ESPCP are defined by the Georgia EPD in Parts IV.B and C, and V.G of the general permit.

In accordance with the above regulations, the following protocol must be followed with regards to the signing of ESPCPs for GDOT projects:

- ESPCPs for projects requiring an NOI must be signed by a GSWCC Level II Certified Design Professional. A Design Professional means a professional licensed by the State of Georgia in the field of engineering, architecture, landscape architecture, forestry, geology, or land surveying or a person that is a Certified Professional in Erosion and Sediment Control (CPESC) and certified by the Certified Professional in Erosion and Sediment Control Inc.
- Consistent with agreement between GDOT and EPD, the signature, seal, and Level II certification number are required on the ESPCP Cover Sheet only.
- The GDOT Chief Engineer stamps, signs, and includes their Level II certification number on the completed ESPCP Cover Sheet prior to submission of final plans to the Office of Construction Bidding Administration (CBA). This includes in-house prepared and consultant prepared ESPCPs. Consultants must sign, seal and certify the ESPCP Cover Sheet prior to certification by the GDOT Chief Engineer.

- Subsequent revisions to the ESPCP must be certified (on the ESPCP Cover Sheet Revision Block) by the Level II Certified Design Professional in charge of the revision. The ESPCP must be amended whenever there is a change in the design, construction, operation, or maintenance that has a significant effect on BMPs with a hydraulic component. Refer to Part IV.C of the general permit. BMPs with a hydraulic component can be defined as requiring hydrologic analyses for design.
- The contractor is responsible for preparing supplemental ESPCPs for construction activities that are not defined in the ESPCP. In these cases, the contractor is required to have a Level II Certified Design Professional prepare, sign and certify the supplemental ESPCP.

9.4.5 Revisions to the ESPCP During the Life of a Project

If the contractor requests to alter the staged construction from that shown in the plans or to utilize construction techniques that render the original ESPCP ineffective, and if GDOT's construction project engineer approves the request, then the contractor has the responsibility of revising and recertifying the ESPCP to reflect all the changes. This should also include any revisions to erosion and sedimentation control pay item quantities.

The contractor may also wish to include several items that are not generally included on the original set of construction plans. These may include: haul roads, batch plants, staging areas, petroleum storage areas, and borrow or waste pits. If these items are not included in the original ESPCPs, the contractor must create a separate ESPCP and obtain all required permits pertaining to additional work that the contractor wishes to perform.

The WECS may authorize minor revisions to the ESPCPs with approval from the Field Project Engineer. Minor revisions only need to be "redlined" on the master set of erosion and sediment control plans kept at the project site and do not need the signature of a GSWCC Level II Certified Design Professional in the cover sheet revision block. Examples of minor revisions include adding silt fence, riprap, or check dams.

A major revision is the addition, deletion, or modification of a structural BMP with a hydraulic component (e.g., those BMPs on which the design is based on hydrological factors). Major revisions to the ESPCP are treated as formal Use on Construction revisions and require a recertification signature in the ESPCP cover sheet revision block by a GSWCC Level II Certified Design Professional. Copies of major revisions are submitted to the appropriate EPD district office.

9.5 Right-of-Way

Make certain that sufficient right-of-way or easement is available for the proper construction and maintenance of all structural BMPs. This concept also applies to post-construction stormwater BMPs, where required. Sufficient area is particularly important when using stream diversion channels and temporary sediment basins. To determine the required area, it is recommended that the designer prepare a preliminary ESPCP prior to right-of-way and easements being finalized.

9.6 BMP Location and Design Criteria

Many BMPs function by catching, filtering, and releasing stormwater runoff slowly. If BMPs are not installed properly or are misapplied, they will not perform effectively. They may even cause hazards

such as the ponding of stormwater on the roadway. For example, inlet sediment traps along the roadway are not usually allowed because they tend to cause stormwater ponding. If the road is open to traffic, hydroplaning may result. Additionally, the impounded stormwater can leave behind a slick sediment residue once it drains. For these reasons, BMPs should never be installed to impound water on the roadway.

Once the construction site nears final stabilization, the project area begins to transition from construction stormwater BMPs (temporary controls) to post-construction stormwater BMPs (permanent controls). An example of this transition would be the conversion of a sediment basin into a dry detention pond after cleaning out sediment, or a temporary diversion channel converted to a vegetative swale. While functioning as a temporary sediment basin, the BMP shall meet retrofitting requirements stated in the Manual for Erosion and Sediment Control in Georgia, current edition. These requirements include but are not necessarily limited to volume requirements and length-to-width ratio requirements. After the BMP is converted to a permanent post-construction BMP, it shall meet the design guidelines for post-construction BMPs in this manual. See GDOT's R.O.A.D.S website for special construction details. See chapter 10 of this manual for more information on post-construction stormwater BMPs.

The information presented in this section is intended for use as a supplement to the Green Book and as an interpretive guide to the NPDES permit requirements. The information provides an overview on construction stormwater BMP implementation and special application of BMPs with respect to their use on GDOT's roadway construction projects. Refer to the Green Book [\(9-2\)](#) for a detailed treatment of BMP application, design, installation, and maintenance, as well as additional illustrations of BMPs.

Chapter 9 References

1. Georgia Department of Transportation (GDOT). 2012. [Plan Presentation Guide](#), Version 01.50.
2. Georgia Soil and Water Conservation Commission (GSWCC – Green Book), 2016. "[Manual for Erosion and Sediment Control in Georgia](#)," 2016 Edition.
3. Thompson, P.L., Kilgore, R.T. 2006, Hydraulic Design of Energy Dissipators for Culverts and Channels, [Hydraulic Engineering Circular No. 14](#), FHWA-NHI-06-086. Federal Highway Administration (FHWA), U.S. Department of Transportation, Washington, D.C.

Chapter 10. Post-Construction Stormwater - Contents

Chapter 10. Post-Construction Stormwater - Contents..... 10-i

10.1 Introduction.....10-1

 10.1.1 Chapter 10 Content Overview10-1

 10.1.2 Additional Resources10-1

10.2 The Need for Post-Construction Stormwater Management.....10-2

 10.2.1 Introduction to Post-Construction Stormwater Management.....10-2

 10.2.2 Stormwater Management for Special Environmental Concerns.....10-3

 10.2.3 Detention Analysis & Downstream Hydrologic Assessment ⁽¹⁰⁻¹⁸⁾10-4

 10.2.4 Water Balance Calculations ⁽¹⁰⁻¹⁸⁾10-10

 10.2.4.1 Basic Equations10-10

10.3 Project Applicability10-15

 10.3.1 Project Level Exclusions10-16

 10.3.2 Outfall Level Exclusions10-18

 10.3.3 Infeasibilities.....10-19

 10.3.4 MS4 Post-Construction Stormwater Management Documentation.....10-20

10.4 MS4 Post-Construction Stormwater Management Minimum Standards10-21

 10.4.1 Stormwater Runoff Quality / Reduction10-21

 10.4.1.1 Runoff Reduction Volume10-22

 10.4.1.2 Water Quality Volume10-24

 10.4.2 Stream Channel / Aquatic Resource Protection.....10-26

 10.4.3 Overbank Flood Protection.....10-35

 10.4.4 Extreme Flood Protection.....10-36

 10.4.5 How the Sizing Criteria Volumes Work Together10-37

 10.4.6 LID and GI Considerations10-38

10.5 Post-Construction Stormwater BMP Selection Criteria.....10-39

 10.5.1 Overview/Introduction of Selection Criteria10-39

 10.5.2 Information Required.....10-40

 10.5.3 BMP Menu.....10-41

 10.5.4 Selection Process.....10-41

10.6 Post-Construction Stormwater BMP Design Criteria10-47

 10.6.1 Filter Strip10-48

 10.6.2 Grass Channel10-57

 10.6.3 Enhanced Swale10-68

 10.6.4 Infiltration Trench.....10-89

 10.6.5 Bioslope.....10-101

10.6.6	Sand Filter	10-110
10.6.7	Bioretention Basin	10-126
10.6.8	Dry Detention Basin	10-140
10.6.9	Wet Detention Pond	10-153
10.6.10	Stormwater Wetland	10-170
10.6.11	Open-Graded Friction Course	10-185
10.7	Detention Design	10-188
10.8	Common BMP Components	10-203
10.8.1	Forebay	10-203
10.8.2	Flow Bypass Structure	10-204
10.8.3	Underdrains	10-207
10.8.4	Level Spreaders	10-208
10.9	Bridge Stormwater Quality Considerations	10-211
10.9.1	Bridge Stormwater Challenges	10-211
10.9.2	Minimizing Direct Discharge	10-212
10.9.3	Bridge Best Management Practices	10-212
10.10	Safety Considerations for Stormwater BMPs	10-214
10.10.1	Motorist Safety	10-214
10.10.2	Public Safety	10-214
10.10.3	Maintenance Personnel Safety	10-215
	Chapter 10 References	10-216

Chapter 10. Post-Construction Stormwater

10.1 Introduction

As of January 3, 2012, stormwater discharges from infrastructure owned and operated by GDOT are regulated by GADNR's EPD through GDOT's MS4 NPDES permit (permit number GAR041000). The permit was renewed on January 3, 2017. Post-construction stormwater management measures have been a part of GDOT policy, but the MS4 permit adds additional requirements. This chapter introduces post-construction stormwater management concepts, defines post-construction requirements of GDOT projects, and provides guidance on meeting these requirements and designing post-construction BMPs.

10.1.1 Chapter 10 Content Overview

The chapter is organized as follows:

- 10.1 Introduction
- 10.2 The Need for Post-Construction Stormwater Management
- 10.3 Project Applicability
- 10.4 MS4 Post-Construction Stormwater Management Minimum Standards
- 10.5 Post-Construction Stormwater BMP Selection Criteria
- 10.6 Post-Construction Stormwater BMP Design Criteria
- 10.7 Detention Design
- 10.8 Common BMP Components
- 10.9 Bridge Stormwater Quality Considerations
- 10.10 Safety Considerations for Stormwater BMPs

10.1.2 Additional Resources

This chapter provides post-construction stormwater management guidance for typical GDOT projects. Chapter 3 provides additional information regarding project milestone requirements, as well as other stormwater planning information. Each project has unique challenges related to stormwater management and the designer should consult GDOT for further guidance if necessary.

In addition to this manual, the GSMM (including the Coastal Stormwater Supplement) can be used as supplemental guidance for GDOT projects. However, this manual will serve as the primary design reference, and where guidance contained within may differ from the GSMM, GDOT policy will apply. GDOT post-construction BMP details and specifications should be reviewed and utilized during BMP design. Post-construction BMP and LID/GI checklists are available as part of the *MS4 Post-Construction Stormwater Report*, found on the [GDOT Manuals & Guides website](#). This report should be used to document BMPs that were considered, excluded, and implemented on projects located in an MS4 area.

10.2 The Need for Post-Construction Stormwater Management

10.2.1 Introduction to Post-Construction Stormwater Management

Post-construction stormwater management (not to be confused with construction stormwater management and associated erosion and sediment controls, which are discussed in chapter 9) refers to the permanent practices and structures put in place to reduce, treat, or minimize stormwater pollution from stabilized, developed areas. BMPs for post-construction applications may include grass channels, filter strips, detention ponds, stormwater wetlands, or any other GDOT-approved BMPs for post-construction.

Pollutants in the roadway are generated from litter, vehicle wear (e.g., brake dust, tire wear), oil and antifreeze leaks, etc. Typical pollutants include suspended solids, dissolved and total metals (typically copper, lead, and zinc), nutrients (e.g., nitrogen, phosphorus), and trash. [\(10-1\)](#) While negative impacts associated with poor runoff quality are a major concern, runoff quantity can be equally troublesome. Increased runoff volume and peak flow as a result of development may cause indirect hydromodification to a stream system. Indirect hydromodification to a stream can include accelerated stream bank or shoreline erosion, changes in sediment transport and temperature, and reduced habitat.

Stormwater pollution may result in a decrease of beneficial or desirable wildlife species and an increase in nuisance species. Stormwater pollution can also have the following negative effects: [\(10-16\)](#)

- Impairment of drinking water supplies
- Increased cost of treating drinking water
- Loss of, or decline in, recreational activities such as swimming and fishing
- Declining property values
- Economic loss related to commercial fishing, tourism, etc.

Georgia is divided into five physiographic regions, based on similarities in geomorphology, character, relief and environment. The regions, shown in Figure 10.2-1 are: Lower Coastal Plain, Upper Coastal Plain, Piedmont, Blue Ridge Mountains, and Ridge and Valley. The Georgia regions may have different stormwater concerns and stormwater solutions due to varying rainfall frequencies and distributions, geography, soil types, etc.

Communities in the northern part of the state are required to consider the effects of stormwater runoff on trout streams. As runoff flows over impervious surfaces, such as asphalt and concrete, the temperature increases and the heated water enters the receiving water. Temperature changes in receiving waterbodies can severely impact certain aquatic species, such as trout, which can survive only within a narrow temperature range. Communities in coastal areas are closely tied to the surrounding surface waters. Some coastal ecosystems are more sensitive to water quality issues. Poor water quality resulting from various sources (manufacturing, agriculture, etc.) can be harmful to the economy, health, and aesthetics of coastal areas. In addition, estuaries serve as nurseries for a significant amount of marine animals. Further, shellfish beds around the nation are often impacted by elevated bacteria levels found in runoff. For these reasons, coastal areas often have more stringent stormwater requirements that GDOT must also take into consideration. Additional information

regarding stormwater management in coastal areas can be found in the *Coastal Stormwater Supplement to the Georgia Stormwater Management Manual*, First Edition, April 2009. (10-15)

Figure 10.2-1 - Physiographic Regions of Georgia
 Reference: Georgia Department of Natural Resources

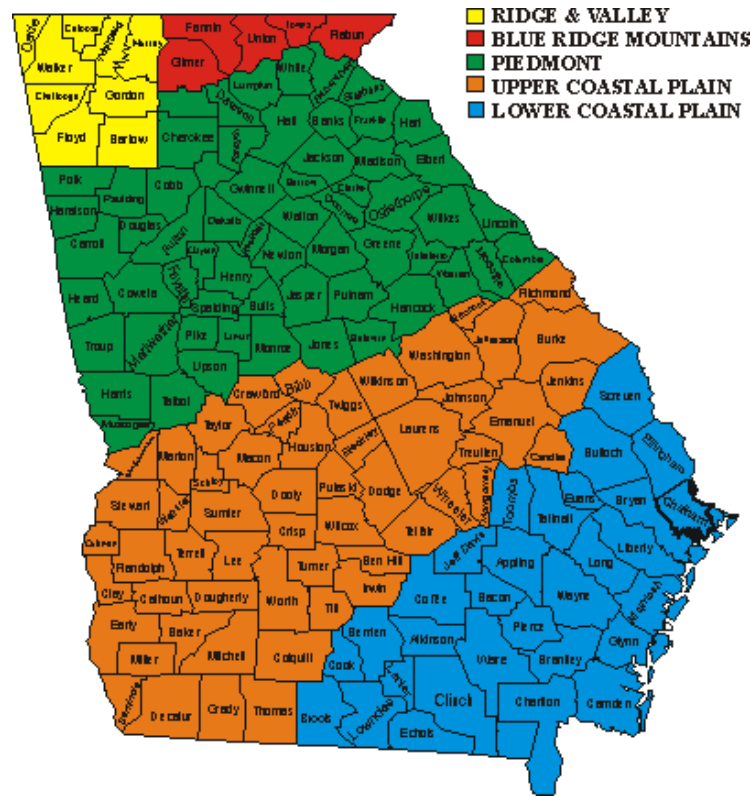

Post-construction stormwater management requires a comparison of post-developed conditions and flows to pre-developed conditions and flows. For GDOT projects, pre-development is defined as the condition of the site immediately prior to the implementation of the proposed project.

Post-construction stormwater management for roadway systems can present some unique challenges. Most entities that are required to manage stormwater are responsible for one discrete area, whereas GDOT roadways span the entire state, making maintenance of stormwater facilities challenging. GDOT right-of-way often limits the amount of space for BMP installation. In addition, GDOT right-of-way is extensively used as utility routes, leaving even less space for BMPs. Roadway safety requirements add additional constraints. All of these factors should be considered during the design of post-construction stormwater BMPs along with other limiting design constraints.

10.2.2 Stormwater Management for Special Environmental Concerns

Post-construction stormwater BMPs may be required for projects not located in an MS4 area due to flows, pollutant loads, increased runoff, or other environmental regulatory requirements. The need for BMPs separate from the MS4 program requirements are often required by regulatory agencies other than the GA EPD due to watershed-specific requirements to address impairments or threatened and endangered species. The GDOT Office of Environmental Services (OES) and the regulatory agency

will determine the specific water quality and/or detention requirements and associated documentation on a case-by-case basis. An MS4 Post-Construction Stormwater Report is only required for projects located in a designated MS4 area. When addressing other environmental regulatory requirements, BMP designs need to follow the design guidance in this Manual and the Special Design Post-Construction Details to the extent possible. Priority should be given to cost-effective and low maintenance BMPs. Refer to Table 10.5-1 for relative cost of common BMPs approved for use on GDOT facilities. Use of BMPs and associated special details other than those shown in Table 10.5-1 or significant design deviations must be reviewed by ODPS prior to approval of plans. GDOT's exclusions and infeasibilities do not apply to post-construction stormwater BMPs required by OES.

10.2.3 Detention Analysis & Downstream Hydrologic Assessment [\(10-18\)](#)

A downstream hydrologic assessment is required for many projects with a post-developed flow increase or to evaluate effects of water quantity control facilities (detention) on peak discharge and timing downstream in the watershed. For maintenance, safety, sign installation, ITS, pedestrian improvements, bridge rehabilitation, and bridge replacement projects (over waterways), a detention report should not be submitted outside of MS4 requirements.

For other projects such as reconstruction and/or widening, the designer must evaluate post-development peak flows to determine if increased flows would cause flooding, spill outside of channel banks, overtop a road, result in some other have adverse effects on downstream properties or if detention will increase downstream flows.

Downstream analysis shall first be accepted by GDOT before specifying detention in the plans. If the project is preparing a Post Construction Stormwater Report, the downstream analysis shall be submitted as part of the Post Construction Stormwater Report. When the project does not need to have a Post Construction Stormwater Report, the detention report, if applicable, shall be submitted at least eight weeks prior to PFPR request. If a designer finds that detention is warranted later in the project, the designer shall coordinate with ODPS as soon as possible, but before purchasing ROW for the BMP and before specifying the BMP in the plans. If detention is recommended to be necessary, documentation of the adverse effects downstream shall be submitted to Design Policy and Support. GDOT will reserve final determination on the necessity of detention. The conveyance from the outfall should also be analyzed for capacity (water levels of 25-year events should stay within channels and pipes should not be in pressure flow).

An exception to this requirement occurs when discharging directly to channels or waterbodies that have drainage areas larger than five square miles (in which case downstream hydrologic assessment is not necessary).

Non-MS4 Detention Report

The purpose of the Non-MS4 Detention Report (Report) is for the designer to provide information supporting its recommendation regarding detention. The information provided must be sufficient to allow GDOT to make an informed decision whether detention should be implemented. The goal of this decision-making process is both to protect downstream properties as much as practicable and to ensure that each proposed permanent BMP is definitively warranted. The Non-MS4 Detention Report template can be located on R.O.A.D.S.

In making recommendations regarding detention for a project, a designer must complete and provide ODPS with the relevant portions of Report and its Attachments A, A-1, and B (with Appendices) in the manner set forth hereinafter. After careful review and consideration of the contents of a Report submitted, the ultimate decision whether detention is warranted and suitable for a project shall be made by GDOT.

If it is being recommended that detention is not warranted for any outfalls, the designer shall submit the first page of the Report and its Attachment A-1 to stormreports@dot.ga.gov for widening projects, reconstruction projects, and new location projects. Since the rest of the Report addresses only those outfalls for which detention is recommended to be warranted and suitable, it is not required to be completed by the designer for submission when detention is not recommended to be warranted and suitable.

Attachment A-1 of the Report covers all outfalls on the project with drainage areas greater than 1 acre that add more than 0.1 acres of impervious area or at least 5% increase in overall drainage area. Outfalls which have contributing drainage areas of less than 1 acre do not need to be included in Attachment A-1. Drainage areas which add less than 0.1 acres of impervious area and less than 5% increase of overall drainage area pre-development to post-development also do not need to be included in Attachment A-1. The designer shall save any supporting documents or calculations within the Design Data Book. Supporting documents or calculations do not need to be submitted with the Non-MS4 Detention Report for outfalls where detention is not warranted.

If the designer recommends that detention may be both warranted and suitable, the designer shall fill out the entire Non-MS4 Detention Report, including all Attachments and Appendices, covering each outfall where detention is being recommended. Once completed, the entire Non-MS4 Detention Report (Report) shall be submitted to stormreports@dot.ga.gov. After being reviewed by ODPS, the Report shall be revised by the designer in any manner as may be directed by GDOT and must ultimately be accepted by ODPS before detention is incorporated into any milestone plan submittal. It should be noted that Report **must** be accepted by ODPS before any purchase can be made of Right of Way for any BMP proposed for detention purposes outside of GDOT's MS4 areas.

Attachment A, GDOT's Post-Construction BMP Summary, must be completed by the designer and submitted with all detention reports recommending detention. The purpose of this documentation is to assist with the plan review process.

There are certain instances where it may not be suitable to implement post-construction BMPs. Criteria for when detention may not be suitable (for non-MS4 detention purposes) include the following:

1. Cases where the project would require an existing roadway alignment change solely to allow for a post-construction BMP. This applies only to existing roadway alignment changes or changes that would create a safety concern.
2. Instances where the installation of post-construction BMPs would require the re-alignment and/or piping of a stream.
3. Implementation of BMPs would cause loss of habitat for endangered or threatened species.
4. Implementation of BMPs would cause significant damage to cultural or community resource such as a historical site, archeological site, cemetery, park, wildlife refuge, nature trail, or school facilities.

5. Implementation of BMPs would result in violation of state or federal law, regulation, or policy. Examples include FEMA regulations and clear zone requirements.
6. Site limitations including shallow bedrock, contaminated soils, high groundwater, utilities, or underground facilities if avoidance or relocation is not suitable.
7. Site does not allow for gravity flow to the appropriate BMP.

GDOT currently allows two types of post-construction BMPs to be initially proposed for detention outside of GDOT's MS4 areas: dry detention basins and wet detention basins. If it is recommended that detention may be warranted, the designer shall first assess a dry detention basin for suitability. If the dry detention basin is considered not suitable, the designer shall next evaluate a wet detention basin for suitability. If both a dry detention basin and a wet detention basin are not suitable, ODPS should be contacted by the designer before proceeding to discuss whether other solutions may be suitable.

The Report's Attachment B, Detention BMP Documentation, is where the designer should include concise summaries for each drainage area evaluation. These summaries should include supporting information which BMPs may be warranted, which BMPs may be suitable, and, if wet detention is selected instead of dry detention, an analysis why dry detention is not recommended to be suitable.

Non-MS4 Detention Report Addendums

An addendum shall be submitted by the designer if there are significant project changes after the Non-MS4 Detention Report has been accepted by GDOT. An addendum shall be submitted if any of the following scenarios occurs:

1. An outfall not previously considered has been identified and the designer recommends detention is warranted and suitable for the outfall.
2. An outfall for which the designer previously recommended that detention was either not warranted or not suitable, detention is now recommended to be both warranted and suitable.
3. An outfall for which the designer previously recommended that detention was both warranted and suitable is now recommended to be either not warranted or not suitable.
4. The type of post-construction BMP recommended at an outfall has changed.

The following information shall be included in the addendum in PDF format and submitted to ODPS for review:

- Cover letter outlining the changes to the recommendations
- Revised cover page including signed, sealed, and dated PE stamp
- Revised Attachment A and Attachment A-1
- Revised sections and associated backup documentation in Attachment B
- Revised appendices, as relevant to the changes to the outfall or BMP
- Current construction plans

After reviewing the information submitted in the addendum, ODPS will make the final determination for whether detention is warranted and suitable.

Downstream Analysis Process

Detention BMPs are designed to attenuate flows, protect streams from bank erosion and hydromodification, and prevent flooding. However, attenuated peak flows from detention facilities can sometimes increase peak flow downstream due to the modified timing and increased overall volume

of runoff. A downstream hydrologic analysis shall be performed for the 25-year storm to determine if combined flows from the project site and other properties have the potential to cause downstream problems.

Figure 10.2-2 illustrates the effect of peak discharge and timing. Detention can alter the peak flow timing so that the combined detained peak flow (the larger dashed triangle) is higher than if no detention is provided. In this case, detention shifts the peak flow to a later time so that, when combined with the flow from the rest of the drainage basin, downstream flooding is worse than if the post-development flow increases were not detained. .

Figure 10.2-2 – Detention Timing Example (10-18)

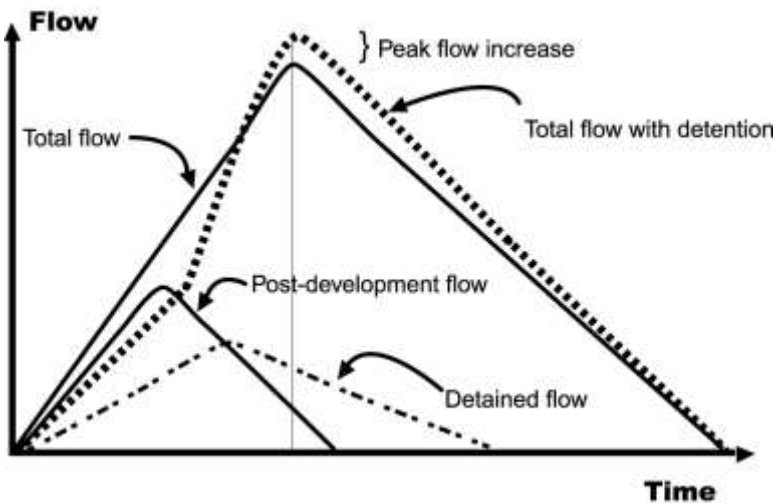
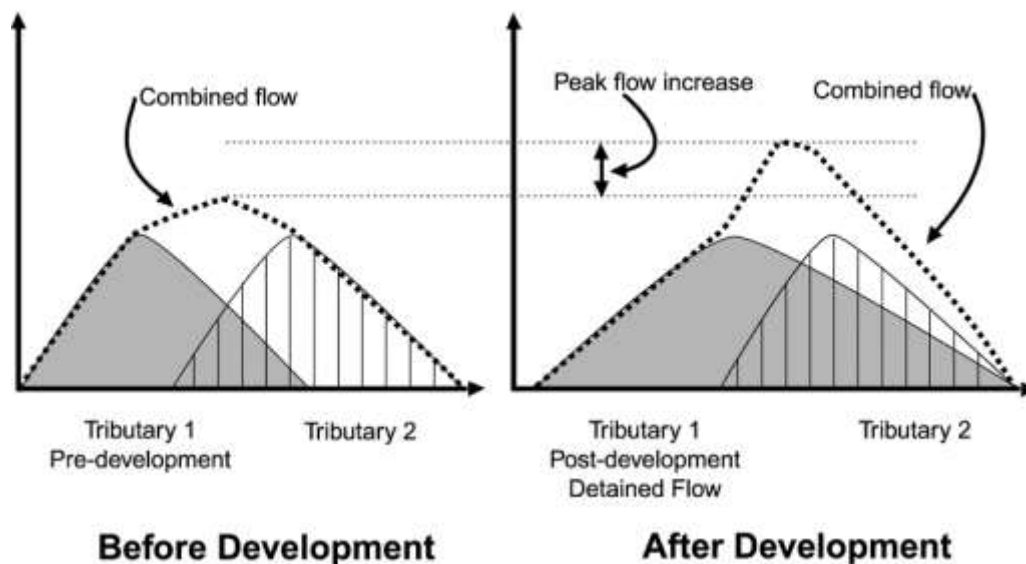

Figure 10.2-3 illustrates how even if the peak flow is effectively attenuated, the longer duration of higher flows due to the increased post-development runoff volume may combine with downstream tributaries to increase the downstream peak flows. The figure shows the pre- and post-development hydrographs from a development site (Tributary 1). The detention results in a post-development runoff hydrograph that meets the flood protection criteria (i.e., the site post-development peak flow is not greater than the pre-development peak flow). However, the post-development combined flow at the first downstream tributary (Tributary 2) is higher than the pre-development combined flow. In this case, the detention volume would have to have been increased to account for the downstream timing of the combined hydrographs to mitigate the impact of the increased runoff volume.

Figure 10.2-3 – Effect of Increased Post-Development Runoff Volume with Detention on a Downstream Hydrograph (10-18)



The downstream analysis should be performed by determining the existing conditions peak flow for the project site. Next, the zone influenced by the project development should be determined by identifying the point downstream at which the project site takes up approximately 9-11% of the total drainage area or where discharges from the project enter a stream or waterbody that is large enough for the site discharges to become negligible. For example, if the structural control (detention facility) drains 5 acres, the downstream analysis point should have a drainage area of about 50 acres or be the point where the discharge enters a large waterbody. Beyond this 10% area or large receiving waterbody, the detention discharge becomes relatively small and insignificant compared to the runoff from the total drainage area at that point. Selecting a downstream analysis point exactly at 10% may not be feasible, and engineering judgement may be required when defining the downstream analysis point. For example, if a point is identified where the project site takes up approximately 12% of the total drainage area, but the next tributary junction is significantly larger in area and would drop the project area to 1% of the total drainage area, choose the point that will more reasonably assess the impacts of the project. In this case that would be the 12% point. The typical steps in the application of the downstream hydrologic analysis are:

1. Determine the target peak flow for each project outfall for pre-development conditions.
2. Using aerial photography and a contour map or other topographic resources, determine the lower limit of the zone of influence (9-11% point or large receiving waterbody) and intermediate locations of concern such as downstream confluences, structures, and conveyances.
3. Obtain the basin characteristics (land use and soil type) for the zone of influence aerial photography, GIS datasets, NRCS web soil survey and other resources as necessary.
4. Calculate the downstream basin time of concentration.

5. Develop a hydrologic model using software (PondPack, TR-55, HydroCAD, Hydraflow), to determine the existing conditions peak flow rates and timing at each tributary junction beginning at the pond outlet and ending at the next tributary junction as close as possible to the 9-11% study point. For authorization to use other software in preparation of a Post Construction Stormwater Report, contact ODPS.
6. Run the model again using post-development conditions at the project site.
Use the following criteria to determine if detention design is warranted.
 - Additional runoff would create (or increase) pressurized flow in downstream pipes for the design year storm.
 - Downstream local, private, or other infrastructure would no longer meet applicable design criteria.
 - Post-developed flows without detention would flood downstream property (one case of this would be if the unattenuated 25-year, 24-hour flows would exceed banks of the conveyance channel). Items to look for are elevations of buildings, basements, driveways, carports, etc.
 - Property downstream has history of flooding and analysis shows flooding would be increased with post-development flows without detention.
 - When the post development 25-year, 24-hour event flow without detention would be increased by more than 10% over the existing peak flow at the downstream point. This does not apply to very low flow increases of 3 cfs or less at the downstream point unless there is a specific risk to property.
 - Erosion and velocity impacts to downstream conveyances cannot be mitigated by armoring

If none of the above conditions are met, detention design is most likely not warranted.

7. Design detention facilities such that the warranting criteria is resolved.
8. If the peak flow does increase, at the downstream hydrologic analysis point because of detention, one of the following must be completed:
 - Remove the detention pond (provided there is capacity to convey the flows harmlessly to the study point),
 - Redesign the detention storage and/or outlet control structure,
 - Receive approval from GDOT to waive detention requirements,
 - Provide infrastructure improvements downstream, or
 - Contact ODPS.

The need for detention facilities should be determined on a case-by-case basis and their use may not be required on certain projects. However, it is the designer's responsibility to provide all necessary supporting documentation for a detention analysis, per outfall, as to whether detention is necessary to prevent downstream impacts. A detention assessment may include numerous factors such as, but not limited to:

- Increase in peak flow rates
- Downstream conveyance capacity
- Environmental impacts
- Downstream detention facilities

When detention facilities are required, the supporting documentation provided by the designer will include the following information:

- Drainage area maps with topography and aerial photography showing existing and proposed drainage basins and flow paths
- Field notes, photographs, and any correspondence with local residents or other contacts
- FEMA or local flood maps (if available)
- Hydrologic & Hydraulic calculations (basin characteristics, routing reports, stage/storage/discharge, peak discharge)

Post-construction BMPs capable of providing detention will be designed in accordance with the BMP design requirements listed in section 10.6 of this manual. Additional information on detention design can be found in section 10.7 of this manual.

10.2.4 Water Balance Calculations [\(10-18\)](#)

Water balance calculations should be completed for post-construction stormwater BMPs that are designed to have a permanent pool of water. The calculations help determine if a drainage area is large enough, or has the appropriate characteristics, to support a permanent pool of water during average or extreme conditions. A simplified water balance procedure is described in the sections below.

10.2.4.1 Basic Equations

Water balance is defined as the change in volume of the permanent pool resulting from the total inflow minus the total outflow (actual or potential):

$$\Delta V = \Sigma I - \Sigma O \quad (10.2-1)$$

Where: Δ = "Change in"

V = Permanent pool volume

Σ = "Sum of"

I = Inflows

O = Outflows

The inflows consist of rainfall, runoff, and baseflow into the BMP. The outflows consist of infiltration, evaporation, evapotranspiration, and surface overflow out of the BMP. Therefore, Equation 10.2-1 can be expressed as follows:

$$\Delta V = P + R_o + B_f - I - E - E_t - O_f \quad (10.2-2)$$

Where: P = Precipitation (ft)

R_o = Runoff (ac-ft)

B_f = Baseflow (ac-ft)

I = Infiltration (ft)

E = Evaporation (ft)

Et = Evapotranspiration (ft)

Of = Overflow (ac-ft)

Rainfall (P) - Rainfall values can be obtained from [NOAA Atlas 14](#). Monthly values are commonly used for calculations of values over a season. The rainfall used in this equation is the direct amount that falls on the permanent pool surface for the specified time period. When multiplied by the permanent pool surface area (in acres) it becomes acre-feet of volume.

Runoff (Ro) - Runoff is equivalent to the rainfall for the period times the “efficiency” of the watershed, which is equal to the ratio of runoff to rainfall. In lieu of gage information, Runoff can be estimated one of several ways. One method has been proposed that uses the volumetric runoff coefficient (R_v), which gives a ratio of runoff to rainfall volume for a particular storm. If it can be assumed that the average storm that produces runoff has a similar ratio, then the R_v value can serve as the ratio of rainfall to runoff.

$$R_v = 0.05 + 0.009(I) \quad (10.2-3)$$

Where: I = Percent of impervious cover as a whole number (e.g., 80 for 80% rather than 0.8)

Not all storms produce runoff in an urban setting. Typical initial losses (often called “initial abstractions”) are normally taken between 0.1 and 0.2 inches. When compared to the rainfall records in Georgia, this is equivalent of about a 10% runoff volume loss. Thus, a factor of 0.9 should be applied to the calculated R_v value to account for storms that produce no runoff. Equation 10.2-4 reflects this approach.

$$Q = 0.9PR_v \quad (10.2-4)$$

Where: P = Precipitation (in)

Q = Runoff depth (in)

Total runoff volume is then simply the product of runoff depth (Q) times the drainage area to the BMP.

$$Ro = \frac{QA}{12} \quad (10.2-5)$$

Where: R_o = Runoff volume (acre-feet)

Q = Runoff depth (in)

A = Total drainage area minus pond area (ac)

Baseflow (B_f) - Most stormwater ponds and wetlands have little, if any, baseflow, as they are rarely placed in line with perennial streams due to environmental regulations. If so placed, baseflow must be estimated from observation or through theoretical estimates. Methods of estimation and baseflow separation can be found in most hydrology textbooks. Detention ponds located in coastal areas, however, often have groundwater baseflow during the wet season. For this situation, the analysis should incorporate estimated seasonal high groundwater level measurements from the project geotechnical investigation.

Infiltration (I) - Determination of the volume estimated to leave the facility by infiltration is complex and depends on many factors including soil type, water table depth, presence and location of rocklayers, surface disturbance and the presence or absence of a pond liner. The infiltration rate is governed by the Darcy equation as:

$$I = Ak_h G_h \tag{10.2-6}$$

Where: I = Infiltration (ac-ft/day)

A = Cross sectional area through which the water infiltrates (ac)

For the purposes of this analysis, use ponding area at the permanent pool

k_h = Saturated hydraulic conductivity or infiltration rate (ft/day)

G_h = Hydraulic gradient = pressure head/distance

G_h can be set equal to 1.0 for pond bottoms and 0.5 for pond sides steeper than about 4:1. The hydraulic conductivity values in Table 10.2-1 or other published resource can be used for planning level estimates including a water balance analysis. Refer to section 10.6 and Appendix J for more information on when infiltration testing is required.

Table 10.2-1 Saturated Hydraulic Conductivity ⁽¹⁰⁻¹¹⁾		
Material	Hydraulic Conductivity	
	in/hr	ft/day
ASTM Crushed Stone No. 3	50,000	100,000
ASTM Crushed Stone No. 4	40,000	80,000
ASTM Crushed Stone No. 5	25,000	50,000
ASTM Crushed Stone No. 6	15,000	30,000
Sand	8.27	16.54
Loamy sand	2.41	4.82
Sandy loam	1.02	2.04
Loam	0.52	1.04
Silt loam	0.27	0.54
Sandy clay loam	0.17	0.34

Table 10.2-1 Saturated Hydraulic Conductivity ⁽¹⁰⁻¹¹⁾

Material	Hydraulic Conductivity	
	in/hr	ft/day
Clay loam	0.09	0.18
Silty clay loam	0.06	0.12
Sandy clay	0.05	0.1
Silty clay	0.04	0.08
Clay	0.02	0.04

Evaporation (E) - Evaporation rates from an open water surface are dependent on differences in vapor pressure, which depend on temperature, wind, atmospheric pressure, water purity, and shape and depth of the pond. Most hydrology textbooks contain a number of methods for estimating and/or measuring evaporation. One common method is the pan evaporation method, though there are only two pan evaporation sites active in Georgia (Lake Allatoona and Griffin). A pan coefficient of 0.7 is commonly used to convert the higher pan value to the lower lake values.

Table 10.2-2 gives pan evaporation rate distributions for a typical 12-month period based on pan evaporation information from five stations in and around Georgia (including the two mentioned previously). Figure 10.2-4 depicts a map of annual free water surface (FWS) evaporation averages for Georgia based on a National Oceanic and Atmospheric Administration (NOAA) assessment completed in 1982. FWS evaporation differs from lake evaporation for larger and deeper lakes, but can be used as an estimate for the type of structural stormwater ponds and wetlands being designed in Georgia. Total annual values can be estimated from this map and distributed according to Figure 10.2-4.

Evapotranspiration (Et) - Evapotranspiration consists of the combination of evaporation and transpiration by plants. The estimation of Et for crops in Georgia is well documented and has become standard practice. Estimates can be obtained from hydrology textbooks or from the NOAA website. However, there is little documented information related to evapotranspiration estimating methods for wetland plants, particularly in Georgia. Evapotranspiration rates are likely insignificant unless emergent vegetation covers a significant portion of the open water surface. In that case, the designer should compare estimates of lake evaporation with crop-based Et estimates and decide which value is most appropriate.

Overflow (Of) - In the water balance calculations, overflow from the facility is either not considered at all, since the concern is for average values of precipitation, or is considered lost for all volumes above the maximum pond storage. When using long-term simulations of rainfall-runoff, large storms play an important part in pond design.

See the wet detention pond example water balance calculation in section 10.6.9.

Table 10.2-2 Evaporation Monthly Distribution (10-11)

Jan	Feb	Mar	Apr	May	Jun	Jul	Aug	Sept	Oct	Nov	Dec
3.2%	4.4%	7.4%	10.3%	12.3%	12.9%	13.4%	11.8%	9.3%	7.0%	4.7%	3.2%

Figure 10.2-4 – Average Annual Free Water Surface Evaporation (in inches)
Reference: NOAA, 1982

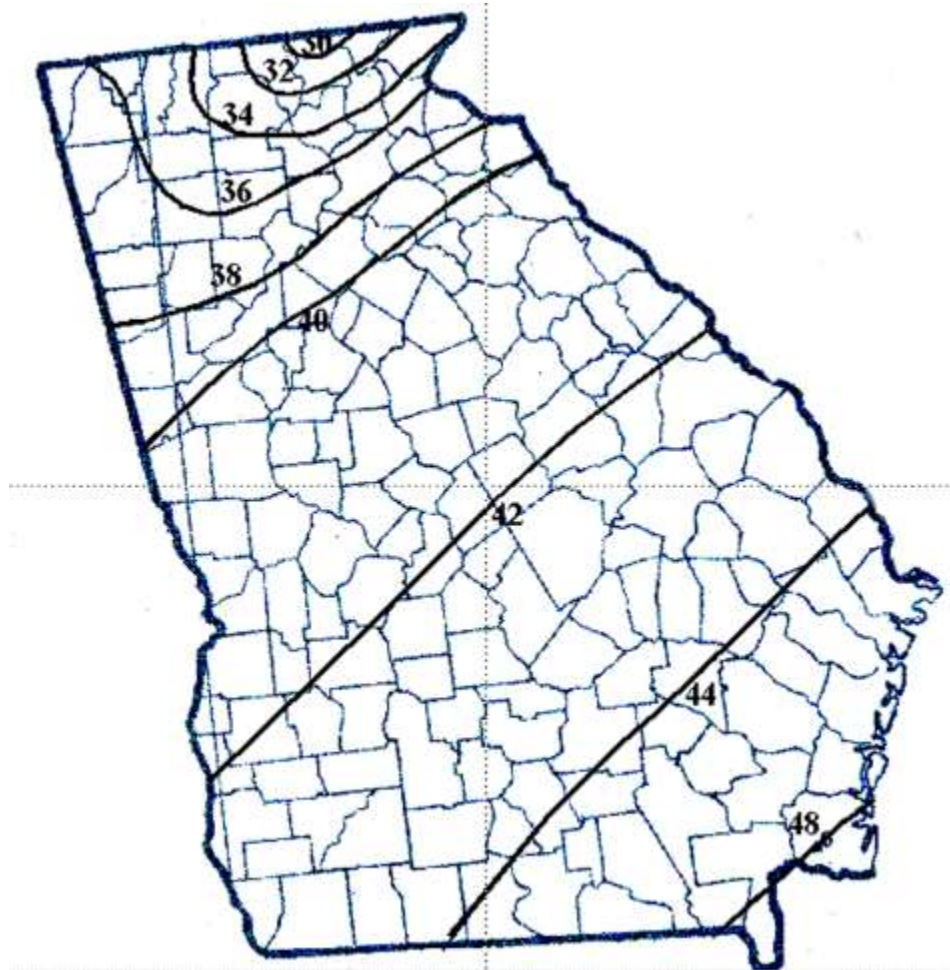

10.3 Project Applicability

Since January 3, 2012, GDOT’s stormwater discharges have been regulated by Georgia EPD through GDOT’s MS4 NPDES permit (permit number GAR041000), most recently renewed on January 3, 2017. The MS4 permit introduced additional stormwater requirements that apply to GDOT including implementation of post-construction stormwater practices to address water quality concerns and permit requirements.

The flowchart provided in Figure 10.3-1 is intended to aid in determining whether MS4 requirements apply to a project. For projects where MS4 requirements apply, section 10.4 summarizes the post-construction stormwater management requirements.

Figure 10.3-1 - MS4 applicability flowchart

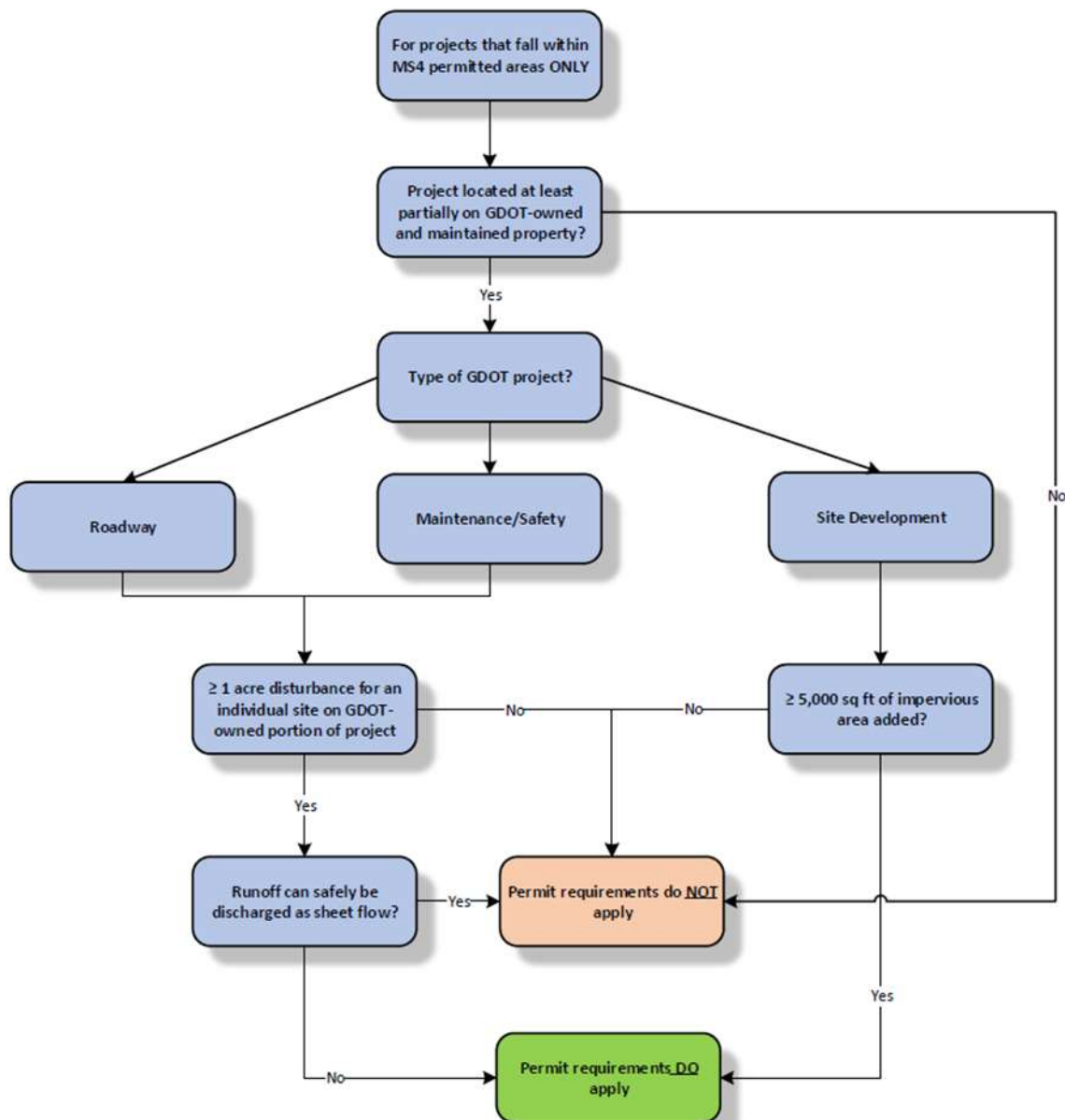

GDOT has a three-tiered process to determine when post-construction stormwater practices are required for MS4 permit compliance.

10.3.1 Project Level Exclusions

If a Project Level Exclusion applies, the entire project is exempt from complying with MS4-related post-construction stormwater requirements. Project Level Exclusions are defined below:

1. Roadways that are not owned or operated (maintained) by GDOT may not require post-construction BMPs. Coordinate with the appropriate local government or entity to determine stormwater management requirements.
2. The project location is not within an MS4 area.
3. Maintenance and safety improvement projects whereby the sites are not connected and the individual site disturbs less than one acre. This includes projects such as repaving, bridge maintenance, maintenance projects that do not add impervious surface area, driveway access paving, shoulder paving and building, fiber optic line installation, sign addition, safety projects whereby the sites are not connected and the individual site disturbs less than one acre, and sound barrier installation.
4. Projects that have their environmental documents approved or right-of-way plans submitted for approval on or before June 30th, 2012.
5. Road projects that disturb less than 1 acre or for site development projects that add less than 5,000 ft² of impervious area.
6. Projects in MS4 areas added to GDOT's 2017 MS4 permit with concept approval (start of preliminary engineering) before January 3, 2018.

MS4 permitted areas include the counties and cities shown in Figure 10.3-2. A list of these cities and counties is provided in [appendix H](#).

Figure 10.3-2 – GDOT MS4 permitted area

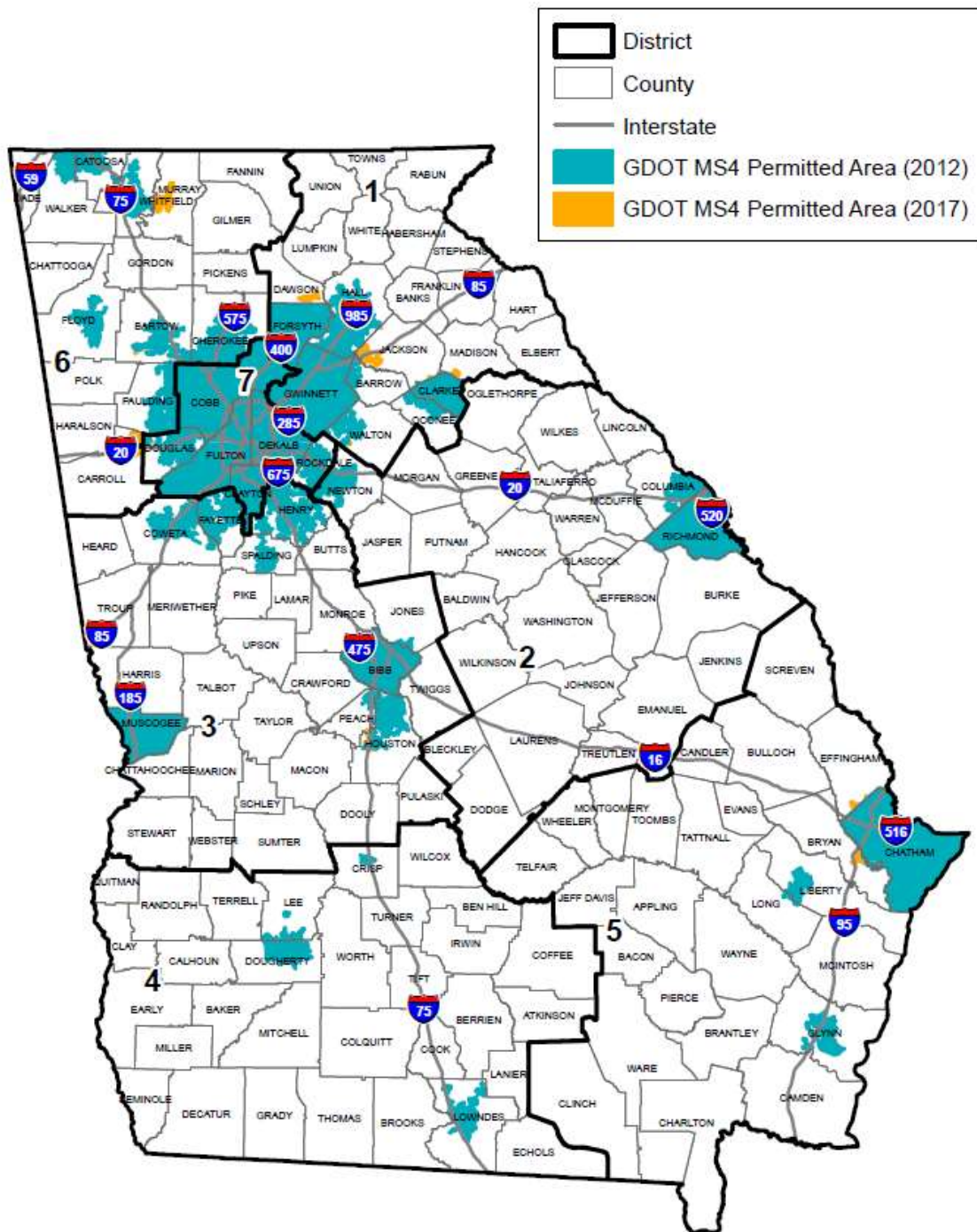

New development and redevelopment projects within MS4 areas must adhere to MS4 permit requirements if they meet one of the following descriptions:

- Linear roadway projects that disturb an area of 1 acre or more; or
- Site development and redevelopment projects that add 5,000 square feet or more of new impervious area

A land disturbance is defined as “any land change which may result in soil erosion from water or wind and the movement of sediments into state water or onto lands within the state, including, but not limited to, clearing, dredging, grading, excavating, transporting, and filling of land.” [\(10-19\)](#)

Impervious area is defined as surface cover that has been affected by infrastructure or development activities such that infiltration of water into the underlying soil is not permitted. Typical examples include paved roads (except those paved with permeable pavement), paved parking, compacted aggregate base course surfaces, and rooftops.

The 2017 MS4 permit requirements apply to projects located in a new MS4 area (i.e. not listed in GDOT’s 2012 MS4 permit) with concept approval on or after January 3, 2018. For projects in MS4 areas that were covered under the 2012 MS4 permit, there is a one-year transition phase to the 2017 permit requirements. The 2017 permit requirements apply for projects that receive Environmental Approval or submit right-of-way plans for GDOT review and approval or Design-Build and P3 projects that receive Environmental Approval or concept approval on or after January 3, 2018.

10.3.2 Outfall Level Exclusions

If a project does not qualify for a Project Level Exclusion, specific outfall drainage areas within a project should be evaluated for applicability of an Outfall Level Exclusion (specific only to an area of the project). Outfall Level Exclusions are defined below:

1. Where installation of post-construction BMPs on the project would require a roadway alignment change solely to allow for BMPs. This exclusion applies only to existing roadway alignment changes that would create a safety concern. A written explanation of the safety concern(s) must be included with the *MS4 Post-Construction Stormwater Report* when claiming this exclusion.
2. Where the installation of post-construction BMPs would require the re-alignment and/or piping of a stream.
3. Where installation of post-construction BMPs on a project would impact existing vegetated stream buffers or wetlands solely for the purposes of installing BMPs. See state stream buffer requirements for additional information.
4. Where stormwater discharges from the project site are designed to exit the right-of-way as sheet flow. Sheet flow should be designed in a manner to ensure that the flow will not cause instability, erosion, or flooding. The designer should determine if this is possible by visiting the site prior to design and is required to provide a written explanation with supporting evidence when claiming this exclusion.

GDOT approval is required to claim this exclusion for instances where stormwater discharges leave the right-of-way as sheet flow but channelize prior to discharging to a receiving stream or waterbody. If a ditch is visible in the cross-section, it is likely that this outfall level exclusion is not applicable.

5. As stated in section 4.2.5.1(a) of the GDOT MS4 permit, “Stormwater runoff that must be treated does not apply to flows that originate outside of GDOT’s right-of-way or diverted flows from undisturbed areas.” If feasible, direct all offsite stormwater around the project site to the cross drain or stream such that it does not combine with stormwater from the project’s impervious surfaces or conveyance systems. This redirection allows the BMPs to only treat

or detain the stormwater that originates from GDOT's site, and stormwater that originates off-site to pass through the right of way unimpeded.

6. As stated in section 4.2.5.1(a) of the GDOT MS4 permit, for outfalls along linear roadway projects whereby the net impervious surface area within that outfall's drainage area has been reduced or remains the same as pre-developed conditions, post-construction stormwater requirements will not apply. Special consideration from GDOT may be given to those projects with a minimal increase in impervious area. In such cases, the designer will be required to provide supporting calculations showing that the increase in stormwater runoff and/or volume required to be treated for water quality is negligible with respect to the drainage area in question, and must also be agreed upon by GDOT. As a general rule increases over one tenth of an acre in impervious surface per basin are not considered negligible.

Note: Outfall Level Exclusions apply separately to each of the four major post-construction stormwater management requirements, which are discussed in detail in section 10.2.2.2.

10.3.3 Infeasibilities

GDOT's MS4 permit requires treatment of stormwater runoff from GDOT property and right-of-way to the maximum extent practicable. Therefore, the requirements and minimum standards described in section 10.4 should be met to the maximum extent practicable. In some situations, site constraints and other factors make implementation of post-construction stormwater BMPs infeasible. The following criteria are used to define these situations (note: criteria should be applied to each outfall drainage basin individually):

1. The BMP costs equal or exceed 10% of the total project costs. Project costs should include:
 - right-of-way acquisition
 - roadway construction (not including Intelligent Transportation Systems (ITS) or toll related expenses)
 - utility relocation
 - mitigation costs

BMP costs should only be compared to the portion of the project within the BMP's associated outfall drainage basin and should include:

- additional right-of-way requirements
 - BMP construction and all other related design elements
2. Implementation of BMPs will cause 90 days or greater of delays to the project.
 3. Implementation of BMPs will cause loss of habitat for endangered or threatened species.
 4. Implementation of BMPs will cause significant damage to a cultural or community resource such as an historical site, archeological site, cemetery, a park, wildlife refuge, nature trail, or school facility.
 5. Implementation of BMPs would result in the displacement of a residence or business.
 6. Implementation of BMPs would result in violation of state or federal law or regulation.

7. Site limitations including: shallow bedrock, contaminated soils, high groundwater, utilities, or underground facilities if avoidance or relocation is infeasible (cost of the relocation equals or exceeds the cost of the BMP).
8. Soil infiltration capacity is limited, where the soil hydraulic conductivity (K) is less than 0.5 in/hr (3.5×10^{-4} cm/second).
9. Site is too small to infiltrate a significant volume.
10. Site does not allow for gravity flow to the appropriate BMP.

If it is determined infeasible to meet all of the minimum standards presented in this section based on the above criteria, the designer should strive to meet as many requirements as possible.

Consideration should be given for locating BMPs anywhere within the limits of the environmental study. Where there is a risk to life or property, the infeasibility criteria should be disregarded in favor of a prudent design.

10.3.4 MS4 Post-Construction Stormwater Management Documentation

MS4 post-construction stormwater requirements shall be considered during Concept Development. At a minimum, the MS4 Concept Report Summary must be submitted with the Concept Report. If the information is available, it is recommended that preliminary drainage areas be delineated and a drainage area map be submitted along with the MS4 Concept Report Summary. The GDOT Stormwater BMP Planning Tool for MS4 Projects may be used to complete an early evaluation of stormwater requirements in each basin. Infeasibility and exclusions are not applied at this time unless the designer is 100% certain they will apply in final design. If there is a possibility that a BMP is feasible for a basin, assume that a BMP will be installed. If a concept-level (preliminary) hydrology study is completed, submit only the following items with the Concept Report:

- MS4 Concept Report Summary
- Drainage Area Map(s)
- GDOT Post-Construction BMP Summary Table (An appropriate summary table format is Attachment B of the MS4 Post-Construction Stormwater Report and can be completed in the GDOT Stormwater BMP Planning Tool for MS4 Projects.)

The MS4 Post-Construction Stormwater Report, found on the [GDOT Manuals & Guides website](#), is required at PFPR and FFPR for ALL projects located in an MS4 area and should be used to document the use or exclusion of post-construction BMPs. This document serves as a design aid and documentation for post-construction stormwater controls on GDOT projects. An *MS4 Post-Construction Stormwater Report Addendum* may be required if there are significant changes to the project after final GDOT approval of the Report is received. Refer to the *MS4 Post-Construction Stormwater Report* template and help files for detailed information on what is required in the Report. Refer to the Plan Development Process Manual and Flowcharts for detailed information on what is required at each project milestone.

10.4 MS4 Post-Construction Stormwater Management Minimum Standards

There are four major post-construction stormwater management requirements (referred to as “minimum standards” in the permit) that apply to GDOT projects meeting the criteria outlined in section 10.3:

- Stormwater runoff quality / reduction (retaining the runoff reduction volume, RR_v , and/or treating the water quality volume, WQ_v)
- Stream channel / aquatic resource protection (CP_v)
- Overbank flood protection (Q_{p25})
- Extreme flood protection (Q_f)

In cases where projects impact existing roadways and facilities, only the new proposed areas should be considered with respect to water quality treatment. The entire drainage area should be considered with respect to stormwater runoff quantity control measures. Existing or pre-developed conditions used in the determination of necessary stormwater runoff quantity control measures are defined as the conditions of the site immediately prior to the implementation of the proposed project. Section 10.5 of this chapter provides BMP selection guidance to aid in meeting the minimum standards.

The requirements associated with stream channel / aquatic resource protection, overbank flood protection, and extreme flood protection are waived for discharge points draining directly to channels or water bodies with drainage areas larger than 5 square miles. Runoff from GDOT right-of-way is not expected to significantly impact surface waters of this size. However, if discharging to a channel with a drainage area less than 5 square miles, the designer must conduct a downstream analysis (as described in section 10.2.3) to verify that proposed condition flows do not exceed existing condition flows causing an impact to life or property.

10.4.1 Stormwater Runoff Quality / Reduction

Small, frequent storms generate the majority of stormwater runoff. In addition, a significant portion of stormwater pollutants generated during large, less-frequent storms are discharged with the initial surface runoff of a rain event, known as the “first flush”. For these reasons, GDOT is required to reduce pollutants in runoff from small storms by retaining runoff onsite (runoff reduction) and/or treating runoff before discharging it offsite.

Runoff reduction practices remove runoff, and therefore pollutants contained in the runoff, through a variety of processes including infiltration (most common and applicable to GDOT projects) evaporation, transpiration, and rainwater harvesting and reuse. Runoff reduction practices improve water quality and reduce the water quantity that must be managed for larger storm events. Designers shall first consider infiltration BMPs, where soils permit. Preference should be given to BMPs that achieve 100 percent infiltration before others are considered.

Runoff reduction is not practicable for all sites and conditions. If the runoff reduction standard cannot be met, the remaining runoff must be treated. Georgia’s water quality standard is the 85th percentile storm (equivalent to 1.2 inches of rainfall). Therefore, where MS4 requirements apply and runoff from the one-inch rainfall even cannot be retained onsite. BMPs must be sized to treat the remaining runoff from the first 1.2-inch rainfall event. See section 10.4.1.2 for additional information on calculating the remaining runoff that must be treated.

In addition to hydrologic benchmarks, requirements include a TSS reduction goal of 80%. Sediment causes aquatic habitat degradation and is a widespread cause of water quality impairment throughout Georgia. In addition, other stormwater pollutants are transported by TSS or are removed in amounts proportional to TSS. (10-15) This 80% reduction requirement is considered to be met if a BMP or system of BMPs, with a pollutant removal rate equal to or greater than 80% TSS, is sized to capture and treat the required water quality volume. If a runoff reduction practice is used but cannot remove the entire first inch of rainfall, the remaining volume (equal to the 1.2-inch rainfall minus the removed volume) must be treated to the 80% TSS removal standard.

10.4.1.1 Runoff Reduction Volume

The volume of runoff resulting from the first one inch of rainfall is known as the runoff reduction volume (RR_v) and is calculated for the new, or net new, impervious area using Equation 10.4-1:

$$RR_v = \frac{1 \text{ in} \times (R_v) \times A \times 43560 \frac{\text{ft}^2}{\text{acre}}}{12 \frac{\text{in}}{\text{ft}}} \quad (10.4-1)$$

Where: RR_v = runoff reduction volume (ft^3)
 R_v = volumetric runoff coefficient, $0.05+0.009(I)$ (dimensionless)
 I = percent imperviousness of onsite area (i.e., for 80% impervious area, use 80, not 0.8)
 A = onsite drainage area of the post-condition basin (acres)

Since GDOT is only required to consider net new impervious area (proposed impervious area minus existing impervious area) in runoff reduction and water quality calculations, new construction projects (projects with no existing GDOT impervious area) and improvement projects (projects with existing GDOT impervious area such as road widenings and intersection improvements) require slightly different approaches for calculating the volumetric runoff coefficient. Improvement projects require that a net volumetric runoff coefficient be calculated. Example calculations for each scenario are provided below.

New Construction Example: 1.5-acre drainage area that is 80% impervious:

$$R_v = 0.05 + 0.009(80) = 0.77$$

$$RR_v = \frac{1 \times (0.77) \times 1.5 \times 43560}{12}$$

$$RR_v = 4,193 \text{ ft}^3$$

For new construction projects, the runoff reduction volume formula can be simplified to the following:

$$RR_v = \frac{1 \text{ in} \times (0.05A + 0.9A_{IMP}) \times 43560 \frac{ft^2}{acre}}{12 \frac{in}{ft}}$$

(10.4-2)

- Where: RR_v = runoff reduction volume (ft³)
- A = onsite drainage area of the post-condition basin (acres)
- A_{IMP} = impervious surface area in the post-condition basin (acres)

Improvement Project Example: 1.2-acre drainage area with 0.9 acres of existing impervious area. The proposed post-development drainage area is 1.5 acres with 1.2 acres of impervious area (Note: any use of the variable “A” refers to the post-basin size):

$$I_{(pre)} = \frac{0.9}{1.5} = 60\%$$

$$I_{(post)} = \frac{1.2}{1.5} = 80\%$$

$$R_{v(post)} = 0.05 + 0.009(80) = 0.77$$

$$R_{v(pre)} = 0.05 + 0.009(60) = 0.59$$

$$R_{v(post)} - R_{v(pre)} = 0.77 - 0.59 = 0.18$$

$$RR_v = \frac{1 \times (0.18) \times 1.5 \times 43560}{12}$$

$$RR_v = 980 \text{ ft}^3$$

For construction improvement projects, the runoff reduction volume formula can be simplified to the following:

$$RR_v = 0.075 \times A_{NEW IMP} \times 43560 \frac{ft^2}{acre}$$

(10.4-3)

- Where: RR_v = runoff reduction volume (ft³)
- $A_{NEW IMP}$ = net increase in impervious area in the post-condition basin (acres)

- Where: VP_{min} = minimum volume of the BMP (ft³)
- RR_v = runoff reduction volume (ft³)
- $RR\%$ = runoff reduction rate for the BMP (obtained from Table 10.5-1)

If the runoff retained onsite in a drainage area is less than the calculated RR_v , the water quality standard must be met for the remaining runoff from the 1.2-inch rainfall event.

10.4.1.2 Water Quality Volume

The volume of runoff resulting from the first 1.2 inches of rainfall is known as the water quality volume (WQ_v) and is calculated for the new, or net new, impervious area as is the case for the runoff reduction volume calculation. The water quality volume formula is:

$$WQ_v = \frac{1.2 \text{ in} \times (R_v) \times A \times 43560 \frac{\text{ft}^2}{\text{acre}}}{12 \frac{\text{in}}{\text{ft}}} \quad (10.4-4)$$

Where: WQ_v = water quality volume (ft^3)
 R_v = volumetric runoff coefficient, $0.05+0.009(I)$ (dimensionless)
 I = percent imperviousness of onsite area (i.e., for 80% impervious area, use 80, not 0.8)
 A = onsite drainage area of the post-condition basin (acres)

The process for calculating the water quality volume for new construction projects and for projects with additional proposed impervious area is identical to the runoff reduction calculations, with the exception that the rainfall value is 1.2 inches.

For new construction projects, the water quality volume formula can be simplified to the following:

$$WQ_v = \frac{1.2 \text{ in} \times (0.05A + 0.9A_{IMP}) \times 43560 \frac{\text{ft}^2}{\text{acre}}}{12 \frac{\text{in}}{\text{ft}}} \quad (10.4-5)$$

Where: WQ_v = water quality volume (ft^3)
 A = onsite drainage area of the post-condition basin (acres)
 A_{IMP} = impervious surface area in the post-condition basin (acres)

For construction improvement projects, the water quality volume formula can be simplified to the following:

$$WQ_v = 0.09 \times A_{NEW IMP} \times 43560 \frac{\text{ft}^2}{\text{acre}} \quad (10.4-6)$$

Where: WQ_v = water quality volume (ft^3)

$A_{NEW\ IMP}$ = net increase in impervious area in the post-condition basin (acres)

For some designs, the drainage basin may substantially change from pre- to post-developed conditions. If this is the case, the post-developed drainage basin should be used in the water quality volume calculations. GDOT will review all drainage basins with proposed substantial changes.

The removal rates given for each BMP in section 10.6 may also be used to determine if the 80% TSS removal requirement has been met. If the TSS removal rate for a given BMP is less than 80%, BMPs may be installed in series (treatment train) to meet the requirement. Composite removal rates can be calculated by using the equation shown below:

$$Total\ TSS\ Removal = BMP1\ removal\ rate + [(remaining\ TSS)(BMP2\ removal\ rate)] + etc.$$

Common BMP treatment train options frequently used to meet the 80% TSS removal requirement include the following (BMPs are listed in order of upstream BMP to downstream BMP). BMPs are listed in order of upstream BMP to downstream BMP. The removal rate of the first BMP is added to the product of remaining TSS and the removal rate of the second BMP:

Filter Strip & Grass Channel: $60\% + [(0.40)(50\%)] = 80.0\%$

Grass Channel & Filter Strip: $50\% + [(0.50)(60\%)] = 80.0\%$

Dry Detention Basin & Grass Channel: $60\% + [(0.40)(50\%)] = 80.0\%$

As stated above, where MS4 requirements apply and runoff from the one-inch rainfall event cannot be retained onsite, BMPs must be sized to treat the remaining runoff from the first 1.2-inch rainfall event. The remaining runoff that must be treated can be calculated by subtracting the runoff reduction volume that was achieved in the basin from the target water quality volume. For example, assume a drainage basin has a target water quality volume of 5,000 cubic feet. A bioslope on HSG A/B soils with a storage volume of 1,376 cubic feet with a can be designed to receive runoff from a portion of the basin. The runoff reduction achieved is 50% (obtained from Table 10.5-1) of 1,376 or 688 cubic feet. Therefore, the remaining volume that must be treated to remove 80% TSS is the target water quality volume of 5,000 cubic feet minus the runoff reduction volume achieved of 688 cubic feet which equals 4,312 cubic feet.

10.4.1.2.1 Calculating Water Quality Volume Peak Flow

Some BMPs, such as grass channels, enhanced swales, and bioslopes are designed to treat a given flowrate rather than volume. This flowrate is the peak discharge for the water quality storm and is referred to as the water quality volume peak flow, or Q_{wq} . In addition, BMPs are often designed in an offline configuration and use a flow bypass structure that allows flows from large storm events to bypass the system. Information regarding online and offline BMP applications can be found in section 10.5. Some flow bypass structures are sized based on flowrate. The Q_{wq} should typically be used for the sizing of these systems. Additional information on flow bypass structures can be found in section 10.8.2.

The following steps can be used to calculate Q_{wq} :

1. Calculate a CN (specific to the calculation of Q_{wq}) using Equation 10.4-7

$$CN = \frac{1,000}{10 + 5P + 10Q_{WV} - 10\sqrt{(Q_{WV}^2 + 1.25Q_{WV}P)}} \quad (10.4-7)$$

Where: Q_{WV} = water quality volume expressed in inches (use 1.2 R_v)
 P = rainfall (inches) (use 1.2 inches)

- The CN is used to determine I_a and subsequently, q_u . Note that guidance for determining q_u (and I_a and t_c) is shown as part of the description for calculating the channel protection volume in section 10.4.2. Use Equation 10.4-8 to calculate Q_{Wq} .

$$Q_{Wq} = q_u \times A \times Q_{WV} \quad (10.4-8)$$

Where: Q_{Wq} = water quality volume peak flow (ft³/s)
 q_u = unit peak discharge (ft³/s /mi²/inch)
 A = drainage area (mi²)
 Q_{WV} = water quality volume expressed in inches (use 1.2 R_v)

The GSMM introduces various site design credits that can be applied to reduce the amount of runoff requiring treatment. Designers are encouraged to familiarize themselves with these site design practices as they are considered LID/GI.

10.4.2 Stream Channel / Aquatic Resource Protection

Urbanization and development increase runoff volumes and velocities, potentially causing channel erosion and loss of aquatic habitat. In order to protect stream channels and aquatic resources, 24-hour extended detention should be provided for runoff from the 1-year, 24-hour storm, referred to as the channel protection volume (CPV). Detention outlets are required to be protected with appropriate energy dissipation and velocity control measures as detailed in Chapters 5 and 8. Also, applicable stream buffers should be preserved at the outlets. Note that CPV control is not required where proposed discharges are less than 2.0 ft³/s.

CP_V can be calculated using the NRCS TR-55 Method. [\(10-34\)](#) Methods presented in TR-55 and the associated WinTR-55 computer model can be used to calculate runoff volume and peak discharges and to develop hydrographs. A simplified peak discharge calculation method based on TR-55 is provided in Equation 10.4-18 in section 10.4.3.

In order to manually approximate channel protection volume, complete the following steps:

- Calculate the direct runoff (Q) for the 1-year, 24-hour storm, (Equation 10.4-9)
- Calculate the initial abstraction ratio, I_a/P (Equation 10.4-12)
- Calculate the time of concentration
- Determine the unit peak discharge, q_u (Figures 10.4-3, 10.4-4 and 10.4-5)
- Determine the peak outflow to peak inflow discharge ratio, q_o/q (Figure 10.4-6)
- Calculate the required storage volume (Equations 10.4-13 and 10.4-14)

Step 1: The SCS Curve Number Method uses Equation 10.4-9 to calculate direct runoff in inches (Q):

$$Q = \frac{(P - 0.2S)^2}{(P + 0.8S)} \quad (10.4-9)$$

Where: Q = accumulated direct runoff (in)
 P = accumulated rainfall (in)
 S = potential maximum soil retention (in)

P is determined by using the National Oceanic and Atmospheric Administration (NOAA) Precipitation Frequency Data Server. (10-25) The NOAA data server can be found online by accessing the following website: <http://hdsc.nws.noaa.gov/hdsc/pfds/index.html>.

Using the interactive map and table for the location nearest the center point of the project site, identify the appropriate rainfall amount for the 1-year, 24-hour storm.

S can be expressed as a function of the SCS curve number, and is calculated using Equation 10.4-10:

$$S = \frac{1000}{CN} - 10 \quad (10.4-10)$$

Where: CN = SCS curve number (most drainage areas will require a composite CN)

A comprehensive list of curve numbers is provided in TR-55. A composite curve number should be calculated for multiple land uses using the following equation:

$$CN_{composite} = \frac{CN_1A_1 + CN_2A_2 + CN_3A_3}{A_1 + A_2 + A_3} \quad (10.4-11)$$

Where: A = surface area

The curve numbers presented in TR-55 assume a prescribed amount of impervious area and can be adjusted for varying amounts of impervious area if needed. The curve number tables also assume that impervious areas are directly connected to the storm sewer system. Curve numbers can be adjusted for drainage areas where this is not the case. Refer to TR-55 for further guidance on adjusting the curve numbers to accommodate these scenarios.

Step 2: The initial abstraction ratio, I_a/P is determined by first calculating the initial abstraction using Equation 10.4-12. The initial abstraction (I_a) is the amount of water lost before runoff begins and includes water retained in surface depressions, water intercepted by vegetation, and evaporation.

$$I_a = 0.2 \times S \quad (10.4-12)$$

Where: I_a = initial abstraction (in)

The P value used in the initial abstraction ratio refers to the same P value used in Equation 10.4-9.

Step 3: The time of concentration, t_c is calculated using the Kinematic Wave Equation. Further guidance for the Kinematic Wave Equation can be found in the FHWA HEC-22. (10-7) Time of concentration is found by summing the following three components of flow starting at the hydraulically most distant point in the drainage area:

1. Sheet flow
2. Shallow concentrated flow
3. Channel flow

Sheet flow is calculated using Equation 10.4-13:

$$T_o = \frac{K_u}{i^{0.4}} \left(\frac{nL}{\sqrt{S}} \right)^{0.6} \quad (10.4-13)$$

Where: T_o	=	sheet flow travel time (min)
n	=	Manning's roughness coefficient, see appendix D (dimensionless)
L	=	Length of sheet flow (ft) with a maximum of 100 ft
i	=	Rainfall intensity (in/hr)
S	=	Surface slope (ft/ft)
K_u	=	Empirical coefficient equal to 0.933 for English units

Since intensity depends on duration, the suggested solution procedure is to assume an initial value for the sheet flow travel time based on physical conditions. The corresponding intensity (i) is then obtained from the applicable intensity-duration-frequency relationship and the equation is solved. The computed T_o is compared to the assumed value for T_o and if they are not the same, the process is repeated until the assumed and computed values for T_o are the same. Note that the minimum time of concentration used for GDOT projects is 5 minutes.

Overland runoff or sheet flow typically collects into what is called shallow concentrated flow prior to flowing in a defined channel or constructed storm drainage facility. This type of flow should be treated separately from overland flow because velocities tend to be higher in these concentrated flow paths. Figure 10.4-1 defines shallow concentrated flow velocities as a function of slope. For water course slopes less than that plotted on Figure 10.4-1 (0.005), use the equations given in the figure to define velocity. It is not always apparent when overland flow changes to shallow concentrated flow and consequently, it is typical to assume a maximum overland flow length of 100 feet if shallow concentrated flow is not evident in the field. Given velocity, the travel time for shallow concentrated flow is computed as follows:

$$T_t = \frac{\text{Flow length}}{\text{Velocity}} \quad (10.4-14)$$

Figure 10.4-1 - TR-55 shallow concentrated flow nomograph

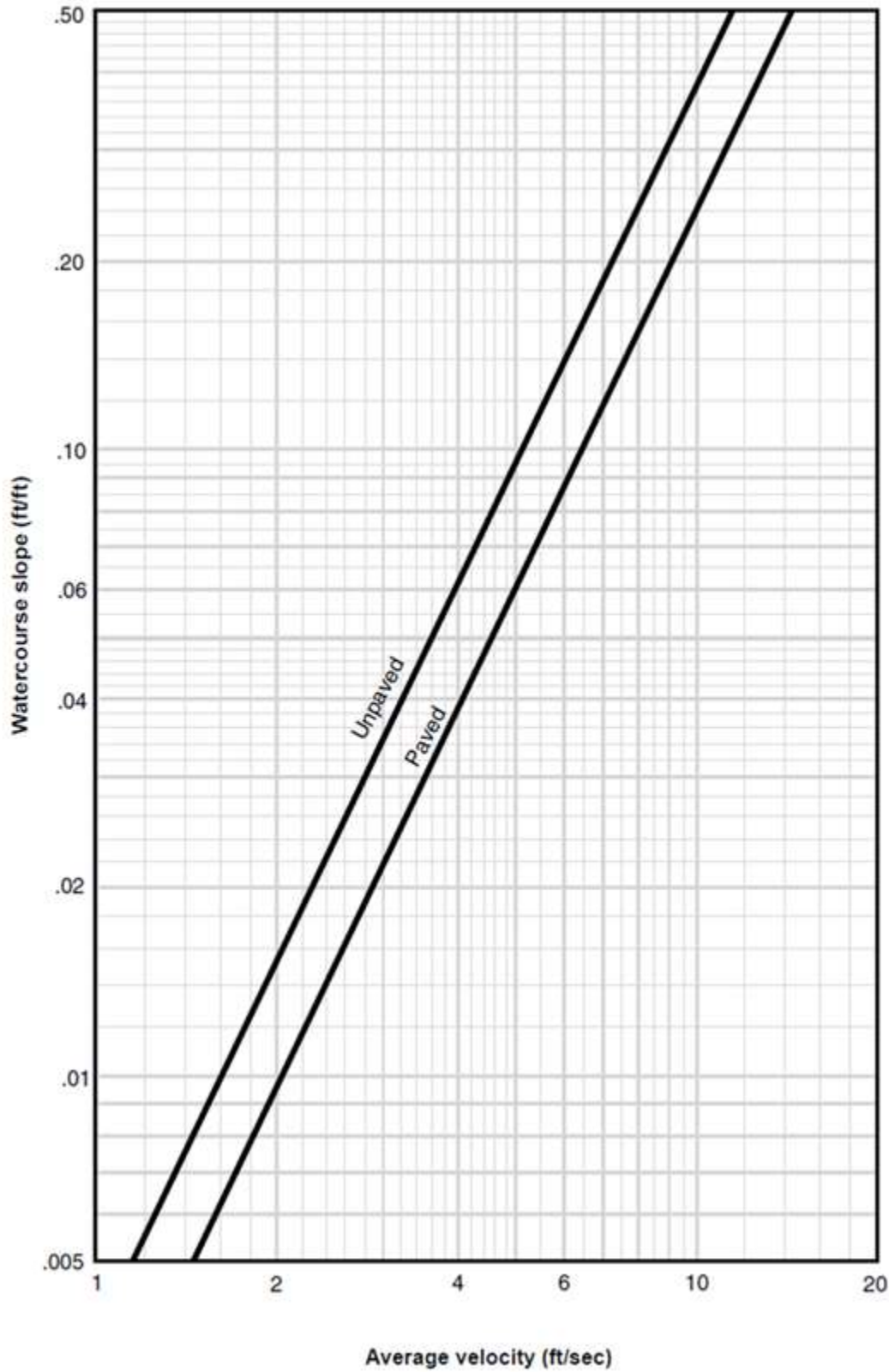

Following shallow concentrated flow, storm drainage flows into natural drainage channels or constructed drainage facilities. This can include flow into swales, ditches, stream channels, or closed conduit drainage facilities. If the flow concentrates in an open channel, the velocity may be estimated from the Manning's equation. Manning's equation is discussed in chapter 4 of this manual.

The time of concentration is the sum of overland flow time, shallow concentrated flow time, and concentrated flow time:

$$t_c = T_o + T_{t(\text{shallow concentrated})} + T_{t(\text{concentrated})} \quad (10.4-15)$$

As previously noted, the minimum t_c that should be used on GDOT projects is 5 minutes.

Step 4: Use the calculated t_c (or the minimum t_c of 5 minutes) and the I_a/P value to compute the unit peak discharge (q_u) from Figures 10.4-3 to 10.4-5 below. If I_a/P falls outside of the ranges provided in the figures, either the limiting values or another peak discharge calculation method should be used.

These figures are specific to an SCS rainfall distribution, which for Georgia is either a Type II or Type III time distribution. They are also specific to peaking factors. Peaking factors may vary from 600 in mountainous regions, to 300 for flat (coastal) areas. A peaking factor of 484 represents rolling hills and is representative of the majority of north Georgia. A peaking factor of 300 should be used for South Georgia, which is characterized by <2% slopes and significant storage (standing water) during storm events. Refer to Figure 10.4.-2 for approximate NRCS TR-55 rainfall distribution and peaking factor geographic boundaries.

Figure 10.4-2 – Approximate rainfall distribution and peaking factor geographic boundaries

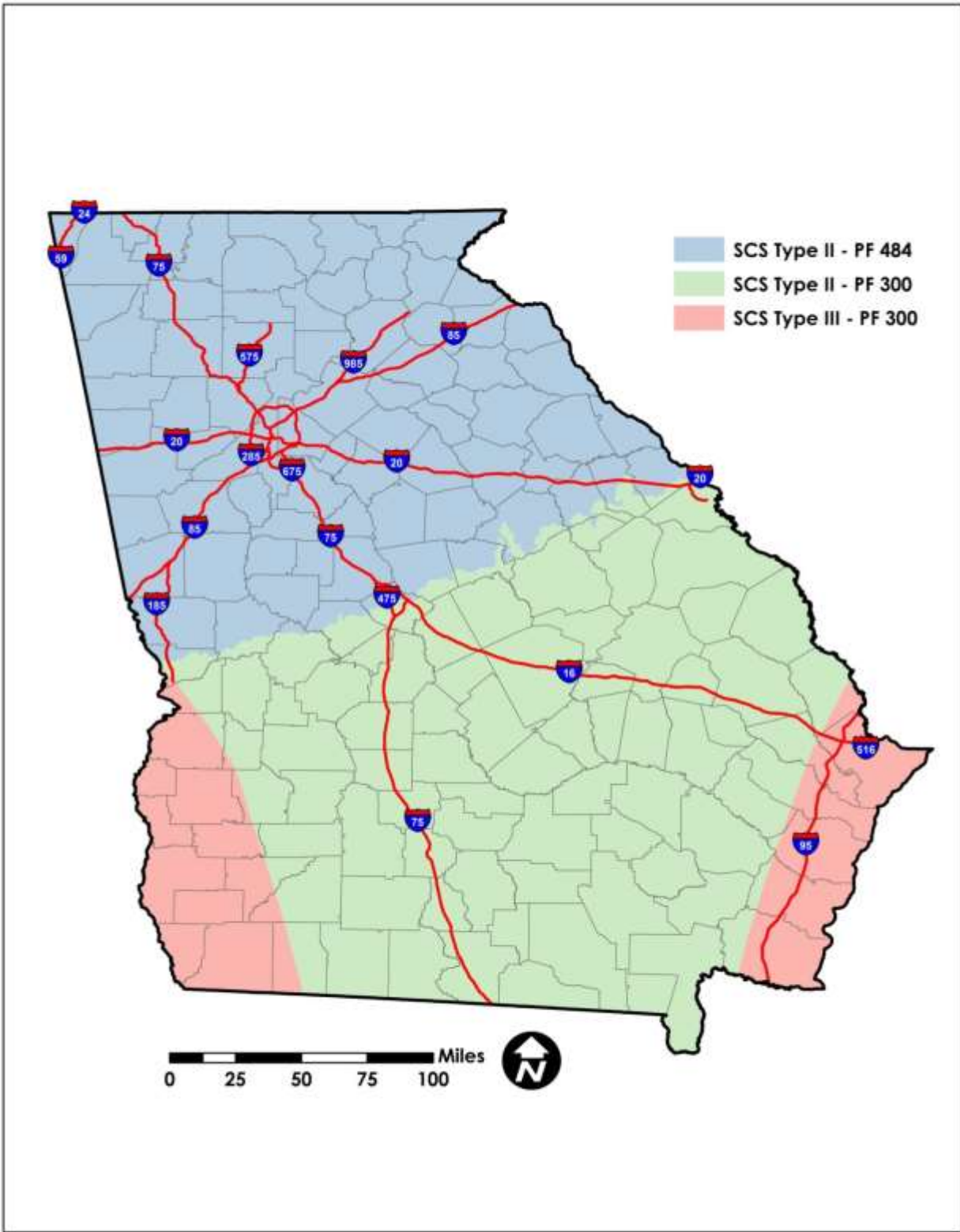

Figure 10.4-3 - Unit peak discharge (q_u) for SCS Type II rainfall distribution and 484 peaking factor (10-34)

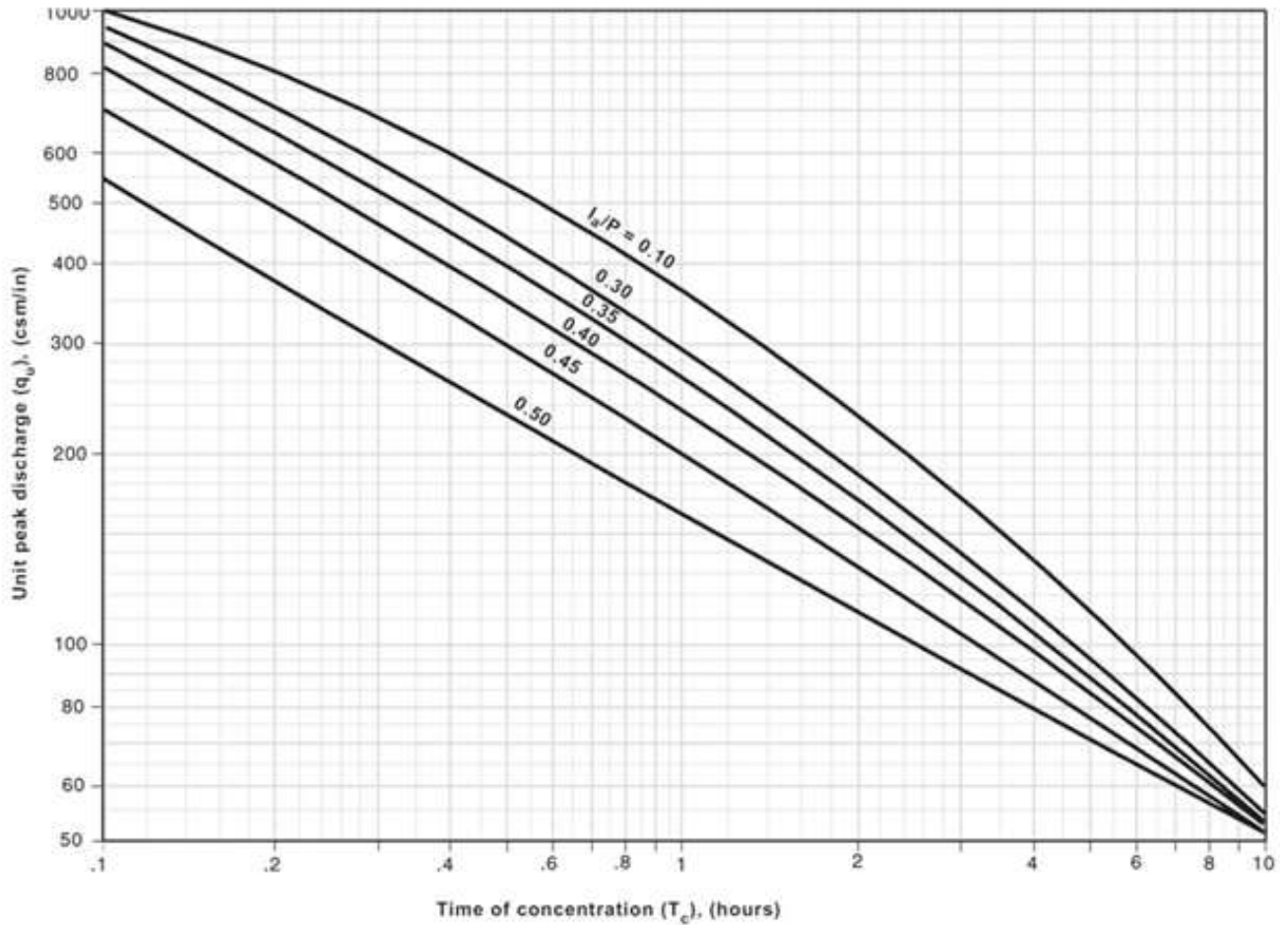

Figure 10.4-4 - Unit peak discharge (q_u) for SCS Type II rainfall distribution and 300 peaking factor

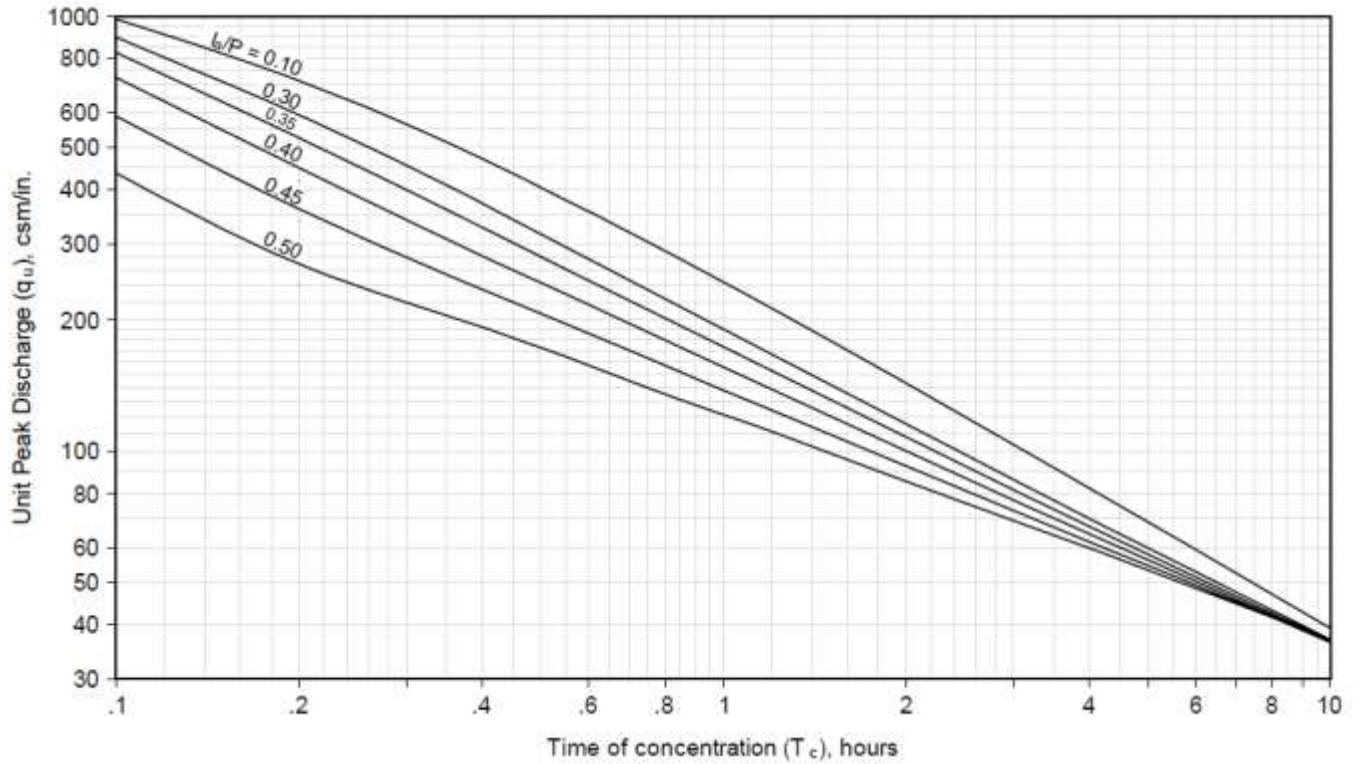
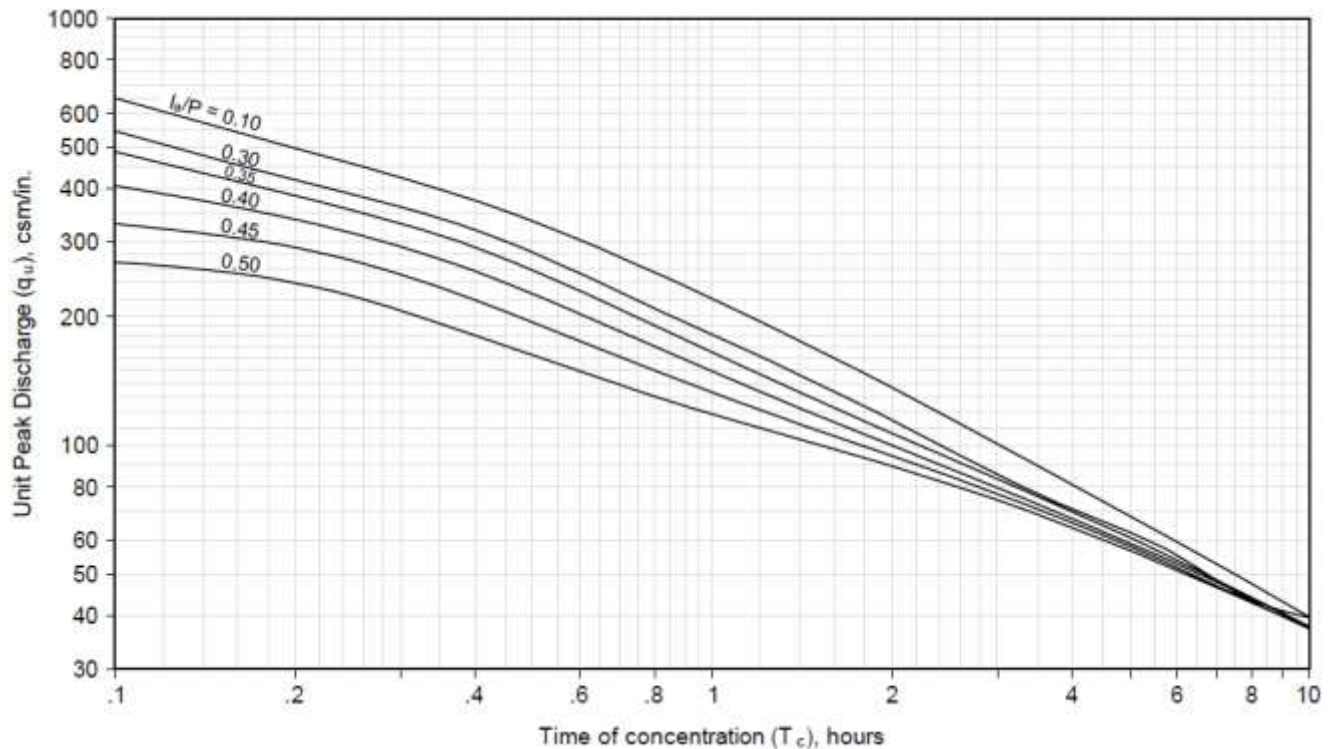
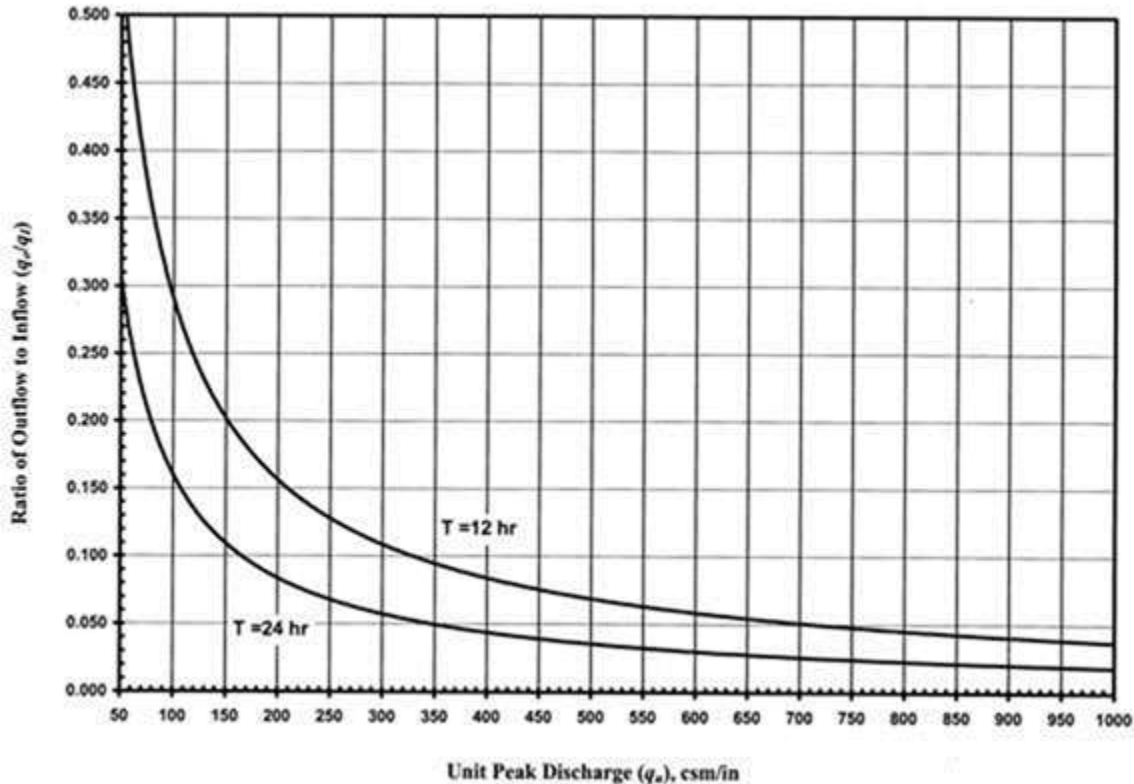

Figure 10.4-5 - Unit peak discharge (q_u) for SCS Type III rainfall distribution and 300 peaking factor



Step 5: Use the unit peak discharge and the T=24 hr curve to determine the ratio of outflow to inflow (q_o/q_i) from Figure 10.4-6.

Figure 10.4-6 - SCS ratio of outflow to inflow curves (10-24)



Step 6: Using the q_o/q_i ratio value calculated from Figure 10.4-6, use Equation 10.4-16 to calculate the required storage volume to runoff volume ratio (V_s/V_r).

$$\frac{V_s}{V_r} = 0.682 - 1.43 \left(\frac{q_o}{q_i}\right) + 1.64 \left(\frac{q_o}{q_i}\right)^2 - 0.804 \left(\frac{q_o}{q_i}\right)^3 \tag{10.4-16}$$

- Where: V_s = required storage volume (acre-feet)
- V_r = runoff volume (acre-feet)
- q_o/q_i = peak outflow discharge to peak inflow discharge ratio

Using the V_s/V_r ratio value calculated above, use Equation 10.4-17 to calculate the required storage volume (V_s).

$$V_s = \left(\frac{V_s}{V_r}\right) \times Q \times A \times 3630 \tag{10.4-17}$$

- Where: V_s = required storage volume - CP_v (ft³)
- Q = direct runoff (inches – 1-year, 24-hour storm for CP_v)

A = total drainage area (acres)

Erosion prevention measures such as energy dissipation and velocity control (i.e., riprap aprons/basins and baffled outlets) should also be employed at outlets to provide stream channel protection. These concepts are discussed in chapter 8 of this manual.

Riparian stream buffers also play an important role in protecting stream channels. Vegetative root systems provide soil structure benefits that prevent erosion. Riparian buffers provide additional stormwater benefits such as runoff velocity reduction, infiltration, and nutrient uptake. Other environmental benefits provided by buffers include wildlife habitat and surface water temperature moderation. A 25-foot buffer applies to all state waters and a 50-foot buffer applies to state waters designated as Trout Streams. Buffers are measured horizontally, starting at “the point where vegetation has been wrested by normal stream flow or wave action.” (10-14) If stream buffer disturbances cannot be avoided, consult the Official Code of Georgia Annotated (O.C.G.A.) 391-3-7-.05 (10-12) and the GA EPD, *Stream Buffer Mitigation Guidance*, April 2011 (10-14) for mitigation requirements and guidance.

10.4.3 Overbank Flood Protection

Overbank flood protection should be provided to protect against flooding from middle-frequency storm events. To meet this standard, the proposed peak flow rate for the 25-year, 24-hour storm (Q_{p25}) must not exceed the existing peak flow rate. This requirement may be waived by the local jurisdiction if the downstream system has adequate capacity to convey the 25-year storm at ultimate build-out. Again, the CP_v , Q_{p25} , and Q_f requirements may be waived for drainage areas that flow directly into surface waters that have a drainage area greater than 5 square miles. The designer must still conduct a downstream analysis (as described in section 10.2.3) to verify that proposed condition flows do not exceed existing condition flows causing an impact to life or property.

The NRCS TR-55 (for drainage areas less than 2,000 acres) or USGS Hydrograph (for drainage areas 25 acres – 25 square miles) methods may be used to calculate Q_{p25} . The TR-55 method is presented here as a majority of roadway drainage basin areas are less than 25 acres. For guidance on the USGS Hydrograph method, refer to the GSMM or chapter 4 of this manual. The GSMM also includes an example calculation for the USGS approach. For full TR-55 procedures, documentation, and example calculations, refer to the TR-55 *Urban Hydrology for Small Watersheds* (10-34) document or the WinTR-55 computer model.

A simplified peak discharge calculation method taken from TR-55 is provided in Equation 10.4-18.

$$Q_p = q_u A Q F_p \quad (10.4-18)$$

Where: Q_p = peak discharge (ft³/s) ($Q_p = Q_{p25}$ for overbank flood protection)
 q_u = unit peak discharge (ft³/s /mi²/in)
 A = drainage area (mi²)
 Q = runoff (in)
 F_p = pond and swamp adjustment factor, see Table 10.4-1

Table 10.4-1 Pond and Swamp Adjustment Factors (10-34)

Percentage of pond and swamp areas	F_p
0	1
0.2	0.97
1	0.87
3	0.75
5	0.72

Complete the simplified NRCS peak runoff rate calculation using the following steps:

1. Determine the rainfall depth (P) for the 25-year, 24-hour storm using the NOAA Precipitation Frequency Data Server (Atlas 14):
https://hdsc.nws.noaa.gov/hdsc/pfds/pfds_map_cont.html?bkmrk=pa.
2. Determine the CN and direct runoff (Q) in inches using the guidance previously provided for determining CP_v . (Equation 10.4-9 and Equation 10.4-11)
3. Use CN to determine initial abstraction (I_a) (Equation 10.4-12) and compute I_a/P .
4. Determine time of concentration (t_c) using the guidance provided in the CP_v section.
5. Use Figures 10.4-3, 10.4-4, and 10.4-5 and guidance in the CP_v section to determine q_u .
6. Determine F_p using Table 10.4-1.
7. Use Equation 10.4-18 to calculate Q_p .

Verify if detention is required by completing a downstream analysis as discussed in section 10.2.3.

To estimate the required storage volume:

1. Complete the above steps to determine the peak runoff rate under pre-developed conditions and post-developed conditions.
2. Determine the peak outflow to inflow ratio (q_o/q_i) by dividing the pre-development peak runoff rate by the post-developed peak runoff rate.
3. Use Equation 10.4-16 to calculate the required storage volume to runoff volume ratio (V_s/V_r).
4. Use Equation 10.4-17 to calculate the required storage volume (V_s).

10.4.4 Extreme Flood Protection

Finally, extreme flood protection should be provided to prevent flood damage from large storms, maintain existing 100-year floodplain boundaries, and to protect the structural integrity of stormwater infrastructure. Extreme flood protection is achieved by controlling the 100-year, 24-hour event (Q_f) so that flooding is not exacerbated by the project. Q_f should be calculated using the same methodologies previously presented for Q_{p25} (NRCS TR-55 or USGS Hydrograph). Q_f must be controlled on-site or by regional structures to maintain the existing 100-year floodplain where structures have already been

constructed within the 100-year floodplain fringe area. Refer to the GSMM for additional guidance. Where the full build-out floodplain is sufficiently sized to account for extreme flow increases, designers may simply size on-site conveyance systems to safely pass Q_f . If detention is used to control Q_f , the same downstream analysis should be performed as described for the Q_{p25} for the 10% zone of influence. As previously stated, the CP_v , Q_{p25} , and Q_f requirements may be waived for drainage areas that flow directly into surface waters that have a drainage area greater than 5 square miles.

10.4.5 How the Sizing Criteria Volumes Work Together

The Water Quality volume (WQ_v) and the Channel Protection volume (CP_v) are calculated individually with their respective volumes determining the elevation/invert of the volume above. For instance, calculations for the WQ_v (computed using the basin area and percent of new impervious area) and CP_v (computed by detaining the 1-year, 24-hour runoff over a period of 24 hours) result in two specific volumes that are contained within the BMP.

The volumes are “nested” when you look at calculating the overall storage requirements of the BMP. While each sizing criteria volume is a separate calculation, the smaller volume(s) are inherent to the larger volume(s). For example, if a BMP is being designed for both the WQ_v and the CP_v , the first step is to calculate both volumes individually. Assume that the WQ_v was calculated to be 6,500 ft³, and the CP_v was calculated to be 45,000 ft³. The additional volume over the WQ_v that the BMP must be designed for in order to meet the CP_v criteria would be 45,000 ft³ – 6,500 ft³ or 38,500 ft³. Since WQ_v is the smallest of the volumes, it is located at the bottom of the BMP along with its appropriately sized orifice. The top of this volume is the invert elevation of the CP_v orifice. Comparing the water quality volume to the stage/storage information of the proposed basin, the invert elevation of the CP_v outlet can be determined. Similarly, the top of the CP_v volume determines the elevation of the subsequent Q_{p25} outlet(s). In the case where these volumes are part of an extended detention basin, these volumes must completely drain within a 24-hour period (Other water quality BMPs may require a longer draw down time. Please refer to subsequent BMP sections in chapter 10 for specific guidance). Consequently, each volume has an individually sized orifice to ensure this requirement is met. The WQ_v orifice is sized so that the water quality volume drains over 24 hours, and the CP_v orifice is sized so that the difference between the CP_v and WQ_v drains over 24 hours.

In addition, the Q_{p25} criterion specifies that the post development 25-year, 24-hour storm peak flow rate not exceed the predeveloped flow rate. The NRCS TR-55 Methodology described in section 10.4.3 provides a process for estimating this volume to provide a starting point for storage design. However, the 1-year, 25-year and 100-year storm events must be routed through the pond and outlet structure to obtain an accurate analysis of BMP performance. The pond outflow characteristics are the result of all outlet devices working in conjunction with each other.

See Figure 10.4-7 for a visual representation of how the sizing criteria volumes and orifice locations work together.

Figure 10.4-7 - Sizing Criteria Volumes Illustration

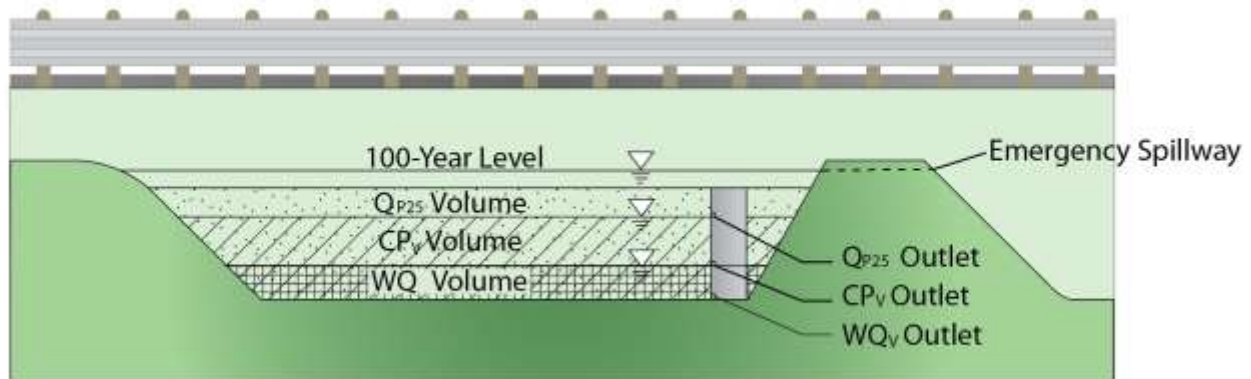

10.4.6 LID and GI Considerations

In addition to the post-construction requirements discussed in this section, the MS4 permit requires the consideration of LID and GI during the design of GDOT facilities. LID and GI definitions can vary according to the source of the definition. The following are definitions provided from USEPA documents.

Low Impact Development:

“...A management approach and set of practices that can reduce runoff and pollutant loadings by managing runoff as close to its source(s) as possible.” LID practices promote the use of natural systems as part of a holistic approach to incorporate infiltration, evapotranspiration, and rainwater harvesting practices. [\(10-36\)](#)

Green Infrastructure:

“An adaptable term used to describe an array of products, technologies, and practices that use natural systems – or engineered systems that mimic natural processes – to enhance overall environmental quality and provide utility services. As a general principle, Green Infrastructure techniques use soils and vegetation to infiltrate, evapotranspire, and/or recycle stormwater runoff.”

https://ofmpub.epa.gov/sor_internet/registry/termreg/searchandretrieve/glossariesandkeywordlists/search.do?details=&glossaryName=Greening%20EPA%20Glossary [\(10-35\)](#)

Although definitions for LID and GI can vary, an important underlying concept includes integrating stormwater BMPs early in the design that promote infiltration, reuse, and evapotranspiration to reduce runoff volume. In addition to removing common stormwater pollutants such as nutrients and TSS, BMPs that reduce runoff volume help recharge aquifers and protect against hydromodification and stream channel erosion. The following LID/GI BMPs should be considered for GDOT projects:

- Reduced roadway footprint
- Porous pavements such as open graded friction course (OGFC) and porous European mix (PEM) on interstate and state route resurfacing and new construction.
- Using rural shoulder in lieu of urban curb and gutter

- Landscaping areas outside of clear-zones with trees
- Post-construction BMPs that allow for infiltration, evapotranspiration, and stormwater harvesting
- Minimize siting on porous soils, erodible soils, or steep slopes (>15%)
- Fitting the design to the terrain
- Following *Better Site Design* principles as presented in the GSMM to reduce post-construction stormwater runoff

Current GI practices already implemented and encouraged by GDOT include the following:

- Using recycled materials such as asphalt and concrete
- Environmental planning to avoid impacting wetlands and surface waters
- Including water quality considerations early in the planning process

In addition, some of the BMPs presented in section 10.6 are considered to be LID/GI practices. LID/GI practices for site development (non-linear) projects can be found in the GSMM. GDOT is required to track the LID/GI practices that were considered during the design of facilities where MS4 requirements apply and report the practices that were implemented. The LID/GI Checklist, an attachment to the *MS4 Post-Construction Stormwater Report* on the [GDOT Manuals & Guides website](#), is used to document this and should be included with each set of plans for projects located in an MS4 area.

10.5 Post-Construction Stormwater BMP Selection Criteria

A multitude of BMP selection methods have been developed with varying degrees of complexity. The selection process outlined in this section is aimed at meeting the post-construction stormwater minimum standards outlined in GDOT's MS4 NPDES permit using the most cost-effective and viable BMPs.

10.5.1 Overview/Introduction of Selection Criteria

There are many factors to consider during the BMP selection process. Some criteria such as the BMP's cost and ability to meet requirements are weighted more heavily in the decision-making process. However, any one factor can render a BMP infeasible. Refer to section 10.3.3 for information on post-construction BMP infeasibility determination. The most common BMP selection criteria are listed as follows:

- Stormwater management and treatment requirements
- Safety
 - Motorist
 - GDOT maintenance staff
 - General public
- Site constraints
 - Available right-of-way

- Soils (e.g., infiltration rate)
- Bedrock and water table
- Topography (adequate slope for gravity flow as well as excessive slopes)
- Setback requirements
- Environmentally or socially-sensitive areas (e.g., stream buffers, endangered species, historic landmarks)
- Cost
 - Capital
 - Operating (maintenance)
 - Service life
- Special watershed or stream considerations
- Maintenance challenges

10.5.2 Information Required

A significant amount of data gathering for selection criteria is needed prior to BMP selection. Designers should familiarize themselves with the project area, receiving water body, and watershed. The following information will aid in the decision-making process:

- Topography
 - Low-relief areas need special consideration because many BMPs require a hydraulic head to move stormwater runoff through the facility
 - High-relief areas may limit the use of practices that need flat or gently sloping areas to reduce sediment and/or runoff flow velocities. High-relief terrain may impact dam heights to the point that the use of a practice becomes infeasible.
- Existing site conditions and land cover
- Anticipated post-construction conditions
- Soils and groundwater data
 - Key evaluation factors are based on an initial investigation of the NRCS hydrologic soil groups at the site. More detailed geotechnical tests are required for infiltration trenches to confirm permeability and feasibility. See Appendix J for more information. For bioretention and enhanced dry swales, the design should utilize infiltration estimates from NRCS soils survey information. Systems will be tested and be adapted, if needed, during construction.
- Underground utilities on site as well as nearby septic systems and water supply wells
- Drainage area characteristics
- Receiving water body and watershed
 - Determine if the project is subject to additional BMP criteria as a result of an adopted local watershed plan or special provision.

- Cold and cool water streams have habitat qualities capable of supporting trout and other sensitive aquatic organisms. Therefore, the design objective for these streams is to maintain habitat quality by preventing stream warming, maintaining natural recharge, preventing bank and channel erosion, and preserving the natural riparian corridor. Table 10.5-2 shows which BMPs can potentially reduce thermal pollution. If a BMP does not provide the possibility of temperature reduction, it is not an appropriate option when discharging to a trout stream.

If the site is considered a hotspot or is located over a water supply aquifer, additional requirements may apply. A hotspot is a land use or activity that has the potential to generate relatively high contaminated stormwater runoff, such as a fueling station or de-icing facility. Refer to Chapter 2 of this manual for guidance on agency coordination and regulations.

10.5.3 BMP Menu

Table 10.5-1 lists BMPs that have been pre-approved for use at GDOT facilities in order of cost effectiveness. Each BMP's runoff reduction and pollutant removal capabilities are also included.

Typically, OGFC will be one of the most cost effective BMPs since it is a material substitution for conventional asphalt pavement. The use of OGFC as a BMP will depend on roadway characteristics rather than site constraints and requires approval for use from OMAT. Therefore, it has been listed last in the list of most cost effective BMPs.

In some cases, additional BMPs presented in the 2016 GSMM may be considered. However, underground detention and proprietary devices will generally not be allowed. Exceptions may be made by GDOT representatives where site constraints prevent the use of other BMPs and when water quality measures are required for environmental reasons other than MS4. For example, stormwater planters/tree boxes may be a suitable alternative in a highly urbanized area. Designers must receive approval from ODPS if a BMP other than one on the pre-approved list is proposed for a project. The following items must be included in the submittal:

- Why the deviation is necessary
- What is the benefit to the Department
- What are the proposed BMP maintenance requirements
- Who will be responsible for BMP maintenance
- What is the anticipated design life of the BMP
- BMP design details
- BMP cost estimate including installation

If approved, refer to the 2016 GSMM for design guidance.

Designers should familiarize themselves with GDOT-approved BMPs prior to beginning the selection process. Section 10.6 includes summary sheets and diagrams providing overviews of each of the approved BMPs.

10.5.4 Selection Process

Online BMP applications provide stormwater treatment or detention within the primary flowpath of runoff. Therefore, this type of application must consider the design volume and control higher design storm flow rates and volumes.

Offline BMP applications provide stormwater treatment or detention away from the primary flowpath of runoff. The simplest method of designing an offline BMP is to place the BMP at a location upstream of the outfall where an area of impervious surface equivalent to the net impervious acreage drains to the BMP. If there is no feasible location to place the BMP where the area of impervious surface is equal to or no more than 1.0 acre greater than the net impervious acreage, proceed with analyzing diversion pipes and bypass structures..

The flow bypass structure is designed to divert only the required treatment of stormwater runoff away from the main conveyance system to the BMP. This reduces the volume and velocity of flow entering the BMP, which often helps limit the amount of erosion or scour near the inlet of the BMP. See section 10.8 for more information on the design of flow bypass structures. In order to use a bypass structure, prior approval from the Office of Design Policy and Support shall be required before incorporating a bypass structure into the design.

If using a separate pipe system to bypass flow, be sure to maintain existing drainage patterns to the greatest extent practical. Where feasible, avoid using parallel or crossing pipes. If parallel or crossing pipes cannot be avoided, provide sufficient clearance between pipes.

In order to combine pre-development outfalls in the post-development condition, prior approval from the Office of Design Policy and Support shall be required before the combined outfalls are incorporated into the design.

LID/GI BMPs must be considered on all applicable GDOT projects and applied where budget and schedule will not be negatively impacted. These are BMPs that reduce impervious area, treat stormwater at the source, replace “grey infrastructure” with natural systems, and utilize infiltration, evapotranspiration, and reuse. Grass channels and filter strips would be examples of LID/GI BMPs and could be used in lieu of curb and gutter. Refer to section 10.4.6 for more information on LID/GI principles.

Other environmental or water quality concerns or issues should be considered where applicable. For example, threatened and endangered species may be present and require consideration during drainage design. Also, appropriate velocity control and energy dissipation should be provided at all outlets to prevent erosion. Refer to chapter 8 within this manual for further guidance. Finally, flood control practices must be implemented where there is a potential impact to life and property. Further information regarding flood control can be found in chapters 2, 8, and 12 of this manual.

The following is a stepwise approach for selecting stormwater BMPs for GDOT facilities. Although the procedures are presented in sequential order, the process will likely be iterative and multiple factors may need to be considered concurrently to arrive at the best solution. Figure 10.5-1 illustrates the BMP selection process. In addition, Table 10.5-1 can be used as an initial screening tool to rule out BMPs that may be infeasible.

Stormwater Treatment Requirements – Using the guidance provided in section 10.4, determine all stormwater treatment requirements, including RR_v , WQ_v , CP_v , Q_{p25} , Q_f , and additional requirements if impaired waters or trout stream protection apply. Eliminate any BMPs that will not achieve treatment goals, keeping in mind that BMPs can be used in series as illustrated in the previous section.

Site Consideration – Review the site for constraints that may preclude the use of certain BMP types and develop a list of appropriate BMPs for use at the site. The first site factor to

consider is the soil type. Evaluate the soil type in the drainage areas to determine if infiltration may be feasible. At Concept, use the NRCS web soil survey, historical geotechnical investigation reports, or other published documentation to determine the soil types. Infiltration should only be considered if the results of the investigation indicate HSG A or B soils in a drainage area. Other potential site constraints include available space, topography, and safety and hazardous concerns presented by the post-construction stormwater BMP. Due to the regular maintenance requirements, all BMPs must be built on right of way and not a permanent easement with the exception of filter strips and grass channels. Based on the site constraints, determine which BMPs are appropriate. It is the obligation of the designer to determine if guardrails are warranted and exercise a standard of care that ensures public safety for each BMP design. Refer to section 10.10 for post-construction stormwater BMP safety considerations.

Preliminary Design and Feasibility – Start the feasibility evaluation with any infiltration BMPs included on the list of appropriate BMPs. Next, prioritize BMPs that are the most cost-effective according to Table 10.5-1. Review the guidance provided in section 10.6 for the applicable BMP, determine an estimated size and identify any additional requirements affecting feasibility of the BMP for the site.

BMP Design – If the BMP is deemed feasible, proceed with the design using the guidance provided in section 10.6. If the BMP is not feasible, repeat the process for another appropriate BMP or state why no BMPs are feasible for the site.

Figure 10.5-1 - BMP selection process flowchart

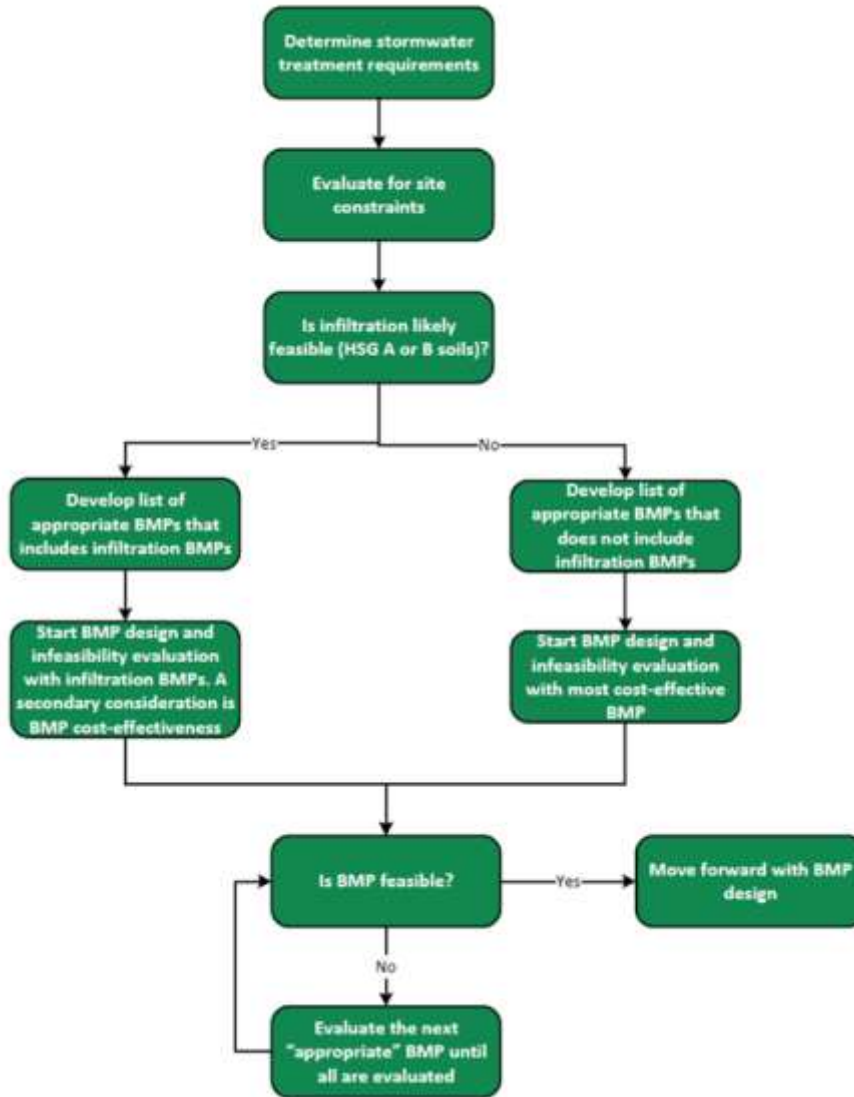

Table 10.5-1 BMP Screening Criteria (adapted from the GSMM)

BMP	Stormwater Treatment										Site Applicability						Cost Considerations		
	RR(%)	WQ _v / TSS (%)	CP _v	Q _{pas} / Q _i	TP (%)	TN (%)	Fecal Coliform (%)	Metals (%)	Detention	Temperature Reduction	Roadway Applicability	LID/GI	Drainage Area (ac)	Space Req'd (% of Imperv. Area)	Max Site Slope	Minimum Head	Depth to Water Table	Construction Cost	Maintenance Burden
Filter Strips	25%	60%	X	X	20%	20%	X	40%	No	Yes	High	Yes	N/A	20%	25%	<1 ft	1-2 ft	Low	Low
Grass Channels	A/B HSG	25%	X	X	25%	20%	X	30%	No	Yes	High	Yes	5 max	10%	4%	<1 ft	2 ft	Low	Low
	C/D HSG	10%																	
Bioslopes	A/B HSG	50%	X	X	60%	25%	60%	75%	No	Yes	High	Yes	N/A	N/A	5%	N/A	2 ft	Med	Med
	C/D HSG	25%																	
Enhanced Dry Swales	w/ open underdrain	50%	?	X	50%	50%	X	40%	Low	Yes	High	Yes	5 max	10-20%	4%	NA	2 ft	Med	Med
	w/ capped underdrain	100%			100%	100%		100%											
Bioretention Basins	w/ open underdrain	50%	?	X	80%	60%	90%	95%	Low	Yes	Med	Yes	5 max	3-6%	20%	3 ft	2 ft	Med-High	Med
	w/ upturned underdrain	75%			100%	100%		100%											
	w/ capped underdrain	100%			100%	100%		100%											
Enhanced Wet Swales	0%	80%	?	X	25%	40%	X	20%	Low	No	High	Yes	5 max	10-20%	4%	1 ft	Below	High	Low
Infiltration Trenches	100%	100%	?	X	100%	100%	100%	100%	Low	Yes	High	Yes	5 max	2-3%	6%	1 ft	4 ft	High	High
Sand Filters	0%	80%	?	X	50%	25%	40%	50%	Low	Yes	Med	Yes	10 max	2-3%	6%	5 ft	2 ft	High	High
Dry Detention Basins	0%	60%	✓	✓	10%	30%	X	50%	Yes	No	Med		75 max	N/A	15%	3 ft	2 ft	Low	Low
Wet Detention Ponds	0%	80%	✓	✓	50%	30%	70%	50%	Yes	No	Low	Yes	10 min*	2-3%	15%	6-8 ft	2 ft (if aquifer)	Low	Low
Stormwater Wetlands – Level 2	0%	85%	?	X	75%	55%	85%	60%	No	No	Low	Yes	5 min	3-5%	Flat	2-3 ft	2 ft (if aquifer)	Med	Med
Stormwater Wetlands – Level 1	0%	80%	✓	✓	40%	30%	70%	50%	Yes	No	Low	Yes	5 min	3-5%	8%	2-3 ft	2 ft (if aquifer)	Med	Med
OGFC	0%	80%	X	X	X	X	X	X	No	No	High	Yes	N/A	0%	N/A	N/A	N/A	Low	Low

✓ -BMP meets the stormwater treatment requirement
 ? - BMP may meet the stormwater treatment requirement depending on size, configuration, and site constraints

X -BMP does not meet the stormwater treatment requirement
 * - Minimum drainage area of ten acres is required to maintain the permanent pool (unless groundwater is present).

Intentionally Left Blank

10.6 Post-Construction Stormwater BMP Design Criteria

This section presents design criteria for BMPs that are pre-approved for use on GDOT projects. The list of pre-approved BMPs currently includes:

- | | |
|--------------------------------|---|
| 1. Filter strips | 7. Bioretention basins |
| 2. Grass channels | 8. Dry detention basins |
| 3. Enhanced swales (dry & wet) | 9. Wet detention ponds |
| 4. Infiltration trenches | 10. Stormwater wetlands |
| 5. Bioslopes | 11. *Open Graded Friction Course (OGFC) |
| 6. Sand filters | |

*Typically, OGFC will be one of the most cost effective BMPs since it is a material substitution for conventional asphalt pavement. The use of OGFC as a BMP will depend on roadway characteristics rather than site constraints and has therefore been listed last in the list of most cost effective BMPs.

Each of the BMP subsections is organized to provide important information needed for the successful design of the BMP. First, the BMP overview page summarizes important considerations associated with each BMP and provides general introductory information. Next, a more detailed description of the function and configuration of the BMP is provided to further familiarize designers with each BMP. An applications/feasibility section is then presented which discusses the site conditions and locations where the BMP may be favorable or should be avoided. Site constraints that may render a BMP infeasible are also presented in this section. Finally, the design section presents the overall BMP sizing procedure and the design process involved for each component. Note that methods and calculations needed for some design elements are presented in various sections of chapter 10 and other chapters of this manual.

All BMP information is focused on the linear application of the BMP. Non-linear applications of these BMPs, such as site development applications or other unique scenarios, will require additional design considerations. The designer is not limited to the pre-approved list of BMPs. The use of any other type of BMP not on the pre-approved list requires following the design deviation procedure and receiving approval from ODPS. Refer to section 10.5.3 for more information.

Following the design discussion, a maintenance section describes design aspects and strategies to facilitate maintenance procedures, help reduce long-term costs, extend the life of the BMP, and improve safety for maintenance personnel. For detailed maintenance information regarding each BMP, see GDOT's *Stormwater System Inspection and Maintenance Manual*, specifically the section on *Post-Construction Structures and Controls*.

Summary

10.6.1 Filter Strip



Advantages	Disadvantages
<ul style="list-style-type: none"> Minimal construction effort and change to existing landscape Effective for highway runoff pollution Adaptable to a variety of site conditions Flexible in design and layout Lower cost alternative Able to be used alone or as a combined measure 	<ul style="list-style-type: none"> Sensitive to erosion and concentrated flow Provides less volume control than most BMPs Large land requirement

Description: A filter strip is a uniformly sloped and vegetated area designed to treat sheet stormwater flow by filtering, slowing, and infiltrating runoff.

Design Considerations:

- Slopes should be between 2% and 25% (perpendicular to the roadway)
- Both the top and toe of the slope should be as flat as possible to encourage sheet flow and prevent erosion

Maintenance Considerations:

- Ensure that runoff is entering strips as sheet flow. Consider installing a level spreader or similar device.

Construction Considerations:

- Before grass has established in the filter strip, bare soil within the area is susceptible to erosion and scour. Any bare earth should be protected with a temporary Type 1 Turf Reinforcement Matting (TRM1).

Applicability for Roadway Projects:

- Highly suitable for roadway projects though they do require considerable right-of-way compared to some other stormwater BMPs.

Stormwater Management Suitability:

- Runoff Reduction
- Water Quality
- Channel Protection
- Overbank Flood Protection
- Extreme Flood Protection

✓ Suitable for this practice ○ May provide partial benefits ✗ Not suitable

LID/GI Considerations

Filtration is the primary treatment mechanism though infiltration is possible where permeable soils exist. Filter strips provide excellent pretreatment when used in combination with other types of structural stormwater BMPs.

Treatment Capabilities

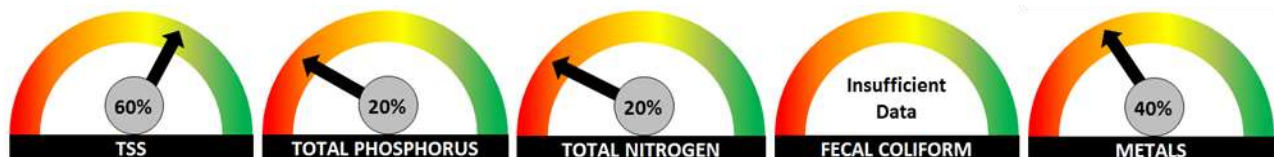

10.6.1 Filter Strip

Description

A filter strip is a uniformly graded and densely vegetated BMP that provides sheet flow, resulting in pollutant removal from stormwater runoff through increased sedimentation, vegetative filtering, and infiltration. Filter strips can be comprised of a variety of shrubs, grasses, and native vegetation to facilitate filtration, increase roughness, and benefit water quality. Filter strips are best suited for treating runoff from roads and highways, roof downspouts, small parking lots, and pervious surfaces. They are also ideal components of the outer or most upland zone of a stream buffer or as pretreatment for another BMP in a treatment train application. Filter strips are most often used in conjunction with rural roadway sections (curb and gutter not present) allowing the shoulder of the roadway to create sheet flow across the filter strip. Filter strips are considered a preferential BMP as they are adaptable in a linear setting, highly cost-effective, and are also considered an LID/GI measure. Figure 10.6.1-1 shows a typical filter strip.

Figure 10.6.1-1 - Typical filter strip configuration

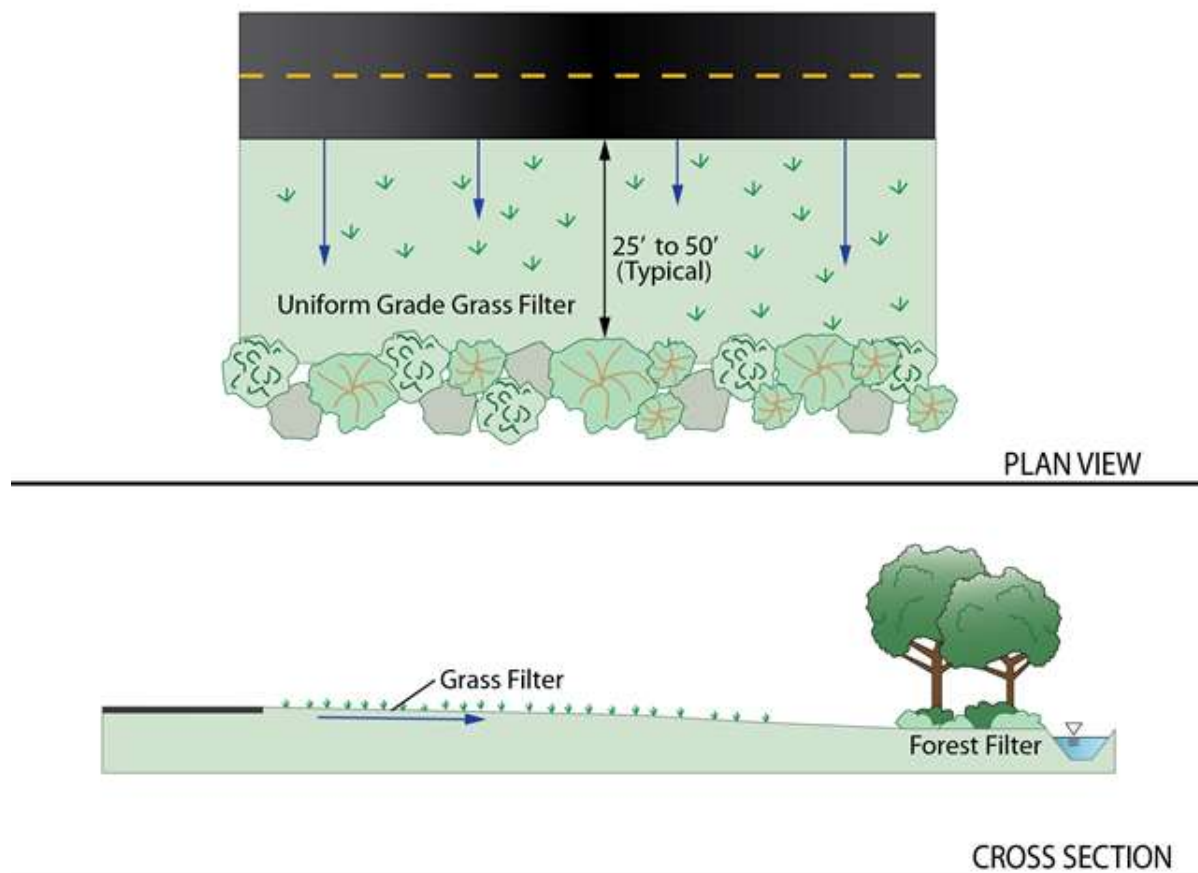

Stormwater Management Suitability

- **Runoff Reduction** – Vegetated filter strips provide partial runoff reduction benefits. They become more effective with increased infiltration rate of the native soils. A filter strip provides 25% of the runoff reduction volume. Performance is dependent on vegetation density and contact time for settling, filtration, and infiltration.
- **Water Quality** – A filter strip is a stormwater treatment practice that can remove a variety of pollutants through several removal mechanisms. Vegetated filter strips are typically used as a pre-treatment component to reduce incoming runoff velocity, filter particulates, and uptake pollutants from the runoff. When sized correctly, they provide a 60% TSS removal efficiency. Either another BMP should be used in a treatment train with the filter strip or the filter strip can be sized for over-conveyance to provide the additional required water quality treatment. Because filter strips are typically situated along the length of a roadway, they may intercept additional drainage area and not just the new impervious surface. GDOT's water quality volume, however, is typically calculated based on the new impervious area only. If there is sufficient existing impervious area in the basin, the filter strip can be sized to for a larger impervious surface area, increasing the overall BMP TSS removal, and meeting GDOT's water quality requirement of 80% TSS removal from new impervious area. This can be achieved if the impervious area treated is at least 1.33 times the new impervious area (in width or additional filter strip length). For example, if a new lane was being constructed with an additional impervious width of 12', the filter strip could be sized for at least a 16' pavement width and intercept the flow from the existing impervious area and meet the 80% TSS removal requirement.
- **Channel Protection** – Another control will be required in conjunction with a filter strip to provide the required detention or other controls necessary
- **Overbank Flood Protection** – Another control will be required in conjunction with a filter strip to reduce the post-development peak flow of the 25-year storm (Q_{p25}) to pre-development levels (detention).
- **Extreme Flood Protection** – Filter strips must provide flow diversion and/or be designed to safely pass extreme storm flows and protect the ponding area, mulch layer and vegetation.

Pollutant Removal Capabilities

Filter strips improve stormwater quality by reducing suspended solids, metals, and nutrients in stormwater runoff through sedimentation and interception, vegetated filtration, and biological uptake. Performance is dependent on vegetation density and contact time for settling, filtration and infiltration. Research on fecal coliform removal has been inconclusive but suggests that filter strips are generally not considered to be effective BMPs for treating bacterial loads. The following average pollutant removal rates may be utilized for design purposes:

- TSS – 60%
- Total phosphorus (TP) – 20%
- Total nitrogen (TN) – 20%
- Fecal coliform – insufficient data

- Heavy metals – 40%

Application and Site Feasibility

Vegetated filter strips are best suited to treat smaller drainage areas. Flow must enter the filter strip as sheet flow spread out over the width (long dimension normal to flow) of the strip, generally no deeper than 1 to 2 inches. If flows will not enter the filter strip as sheet flow, special provision must be made to ensure design flows spread evenly across the filter strip.

Please note that flows that discharge from a filter strip across right-of-way boundaries and do not immediately concentrate may qualify for an outfall level exclusion and would not need to meet the filter strip criteria outlined in this section.

Siting information and constraints follow:

- **Drainage Area** – Filter strips generally have a maximum drainage area of 5 acres, but 2 acres is preferred.
- **Space Required** – Filter strip surface area is dependent on contributing drainage area and the slope of the filter strip. A drainage area to filter strip surface area ratio of 2:1 is recommended. Utilize available vegetated roadway shoulder as a roadside filter strip when possible. Locate the filter strip on the right-of-way or in a permanent drainage easement with appropriate access.
- **Site Slope** – Filter strips should be designed with slopes between 2% and 25% (perpendicular to the roadway). Greater slopes would encourage the formation of concentrated flow. Flatter slopes would encourage standing water. The sheet flow depth through the filter strip should be no more than 2 inches.
- **Depth to Water Table** – The seasonal high water table should be at least 1 foot lower than the ground at any point along the filter strip.
- **Soils** – Verify there are no bare spots present on existing slopes.
- **Vegetation** – Vegetation should be specified per Section 700 – Grassing.
- **Flow Velocity and Depth** – Use Table 10.6-1-1 to ensure velocity and depth requirements are met.
- **Other Constraints/Considerations:**
 - Riparian buffer should not be cleared for filter strip construction. Pedestrian traffic across the filter strip should be limited through channeling onto sidewalks.
 - The filter strip should be at least 15 feet long (25 feet preferred) to provide filtration and contact time for water quality treatment. The recommended maximum strip length is 48 feet.
 - Where flows become concentrated, using a level spreader to redistribute flow may be warranted near slope transitions, ESAs, adjacent properties, or areas exceeding an overland flow length of 75 feet for impervious surfaces and 100 feet for pervious surfaces (see Additional Design Considerations and section 10.8 of this chapter for level spreader guidance).

- Filter strips are typically an on-line practice. On-line practices provide stormwater control within the flowpath of the runoff, conversely off-line practices provide stormwater control away from the flowpath. Both the top and toe of the slope, immediately preceding and following the filter strip, should be designed to encourage sheet flow and prevent erosion by minimizing slope in these areas.

Figure 10.6.1-2 shows a filter strip in a typical on-line application.

Figure 10.6.1-2 - Typical filter strip components and treatment processes

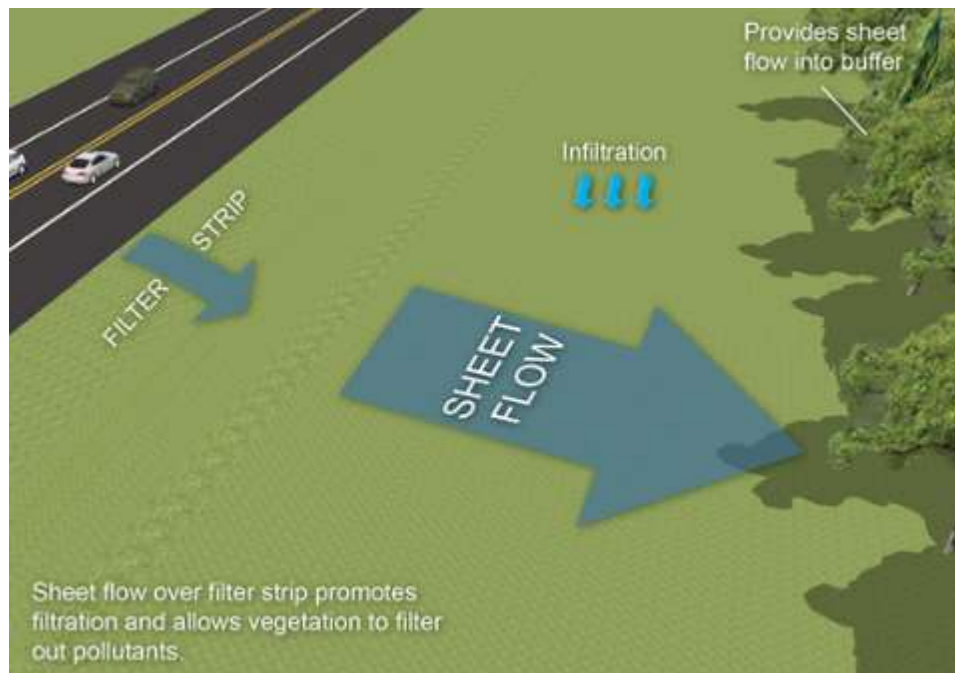

Data for Design

The data needed for filter strip design may include the following:

- Existing and proposed site, topographic and location maps, and field reviews
- Field measured topography or digital terrain model (DTM)
- Aerial/site photographs
- Drainage basin characteristics (slope, shape, size, soils, and land use)
- Preliminary plans including plan view, roadway and drainage profiles, cross sections, utility plans, and soil report
- Environmental constraints
- Design data of nearby structures (storm sewer as built information)
- Additional survey information

After initial data gathering, the contributing drainage area should be delineated and water quality volume and/or associated peak flow draining to the most downstream segment of the filter strip should be calculated based on post-project land use conditions (refer to section 10.4.1.2 of this chapter).

Next, preliminary dimensions for the filter strip area, roughness coefficient, and design slope should be determined. Location and general configuration for the filter strip should be set based on the above siting information.

The slope of the filter strip parallel with the roadway should be as flat as possible; however, this is usually influenced by the roadway profile, or shoulder slope. (10-26) A typical filter strip design for a roadway application is depicted in Figure 10.6.1-3 below.

Figure 10.6.1-3 - Typical filter strip design for a roadway application

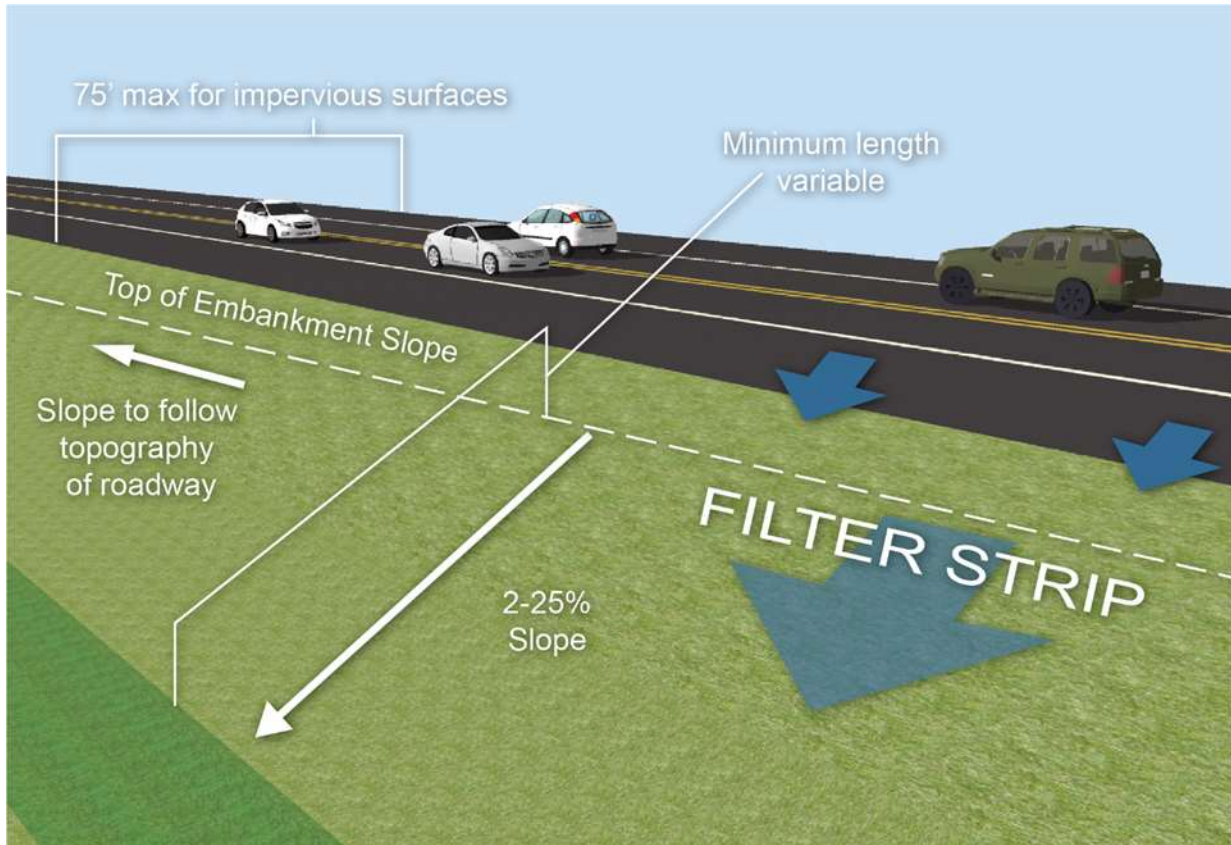

Vegetation

A variety of shrubs, grasses, and native vegetation can also be used to facilitate filtration, increase roughness and benefit water quality. A list of grasses and vegetation appropriate for use in Georgia can be found in GDOT specification section 700.

Pretreatment

A number of other BMPs, including bioretention areas and infiltration trenches, may employ a filter strip as a pretreatment measure in a treatment train application.

Filter Strip Sizing

Table 10-6.1-1 has been developed based on providing a contact time of 5 minutes. The table assumes that drainage from the pavement will sheet flow across the filter strip. Please note that the steepest portion of the slope should be utilized in the sizing of the filter strip. For instance, most

shoulders have a 6% slope of grassing coming off of a paved shoulder going to a 4:1 slope. The designer would use the 4:1 slope and the pavement width to determine the length of filter strip.

Table 10.6.1-1 Filter Strip Length for Select Applications						
Pavement Width (ft)	Filter Strip Length (ft)					
	Slope 4:1	Slope 6:1	Slope 8:1	Slope 6%	Slope 4%	Slope 2%
12	25	22	20	16	15	15
14	27	24	22	17	15	15
16	28	25	23	18	16	15
18	29	26	24	19	17	15
20	31	27	25	20	18	15
22	32	28	26	21	18	15
24	33	29	27	21	19	15
26	34	30	28	22	20	16
28	35	31	28	23	20	16
30	36	32	29	23	21	17
32	37	33	30	24	21	17
34	38	34	31	25	22	18
36	39	34	31	25	22	18
38	40	35	32	26	23	19
40	40	36	33	26	23	19
42	41	36	33	27	24	19
44	42	37	34	27	24	20
46	43	38	35	28	25	20
48	43	38	35	28	25	20
50	44	39	36	29	26	21
52	45	40	36	29	26	21
54	46	40	37	30	26	21
56	46	41	38	30	27	22
58	47	42	38	31	27	22
60	48	42	39	31	27	22

**The table above has been developed to provide a 5-minute contact time across the filter strip for water quality events for runoff from a roadway.*

Maintenance Considerations

Without proper maintenance, BMPs will function at a reduced capacity and may cease to function altogether. Maintaining the vegetative cover and sheet flow over the filter strip is essential to the proper operation of the filter strip. A properly designed BMP includes access considerations for maintenance:

- Provide adequate right-of-way or easement.
- Follow normal maintenance activities for grassed slopes including inspecting for erosion and ensuring dense vegetation

Refer to GDOT's *Stormwater System Inspection and Maintenance Manual*, for specific maintenance requirements.

Filter Strip Example Calculation

GIVEN:

- A new roadway project located in Atlanta, Georgia.
- The proposed project includes 200 feet of roadway (in length).
- The drainage area that discharges to the filter strip includes the following: two 12-foot lanes and a 6-foot paved shoulder that will drain via sheet flow directly into the filter strip.
- Assume no stormwater is collected as “off-site” or “bypass” runoff.
- Assume that the existing ground and available right-of-way is sufficient for a filter strip with a shoulder slope of 4% and length of 200 feet.
- Assume a dense grass will be used.
- $WQ_v = 571 \text{ ft}^3$; $Q_{wq} = 0.245 \text{ ft}^3/\text{s}$

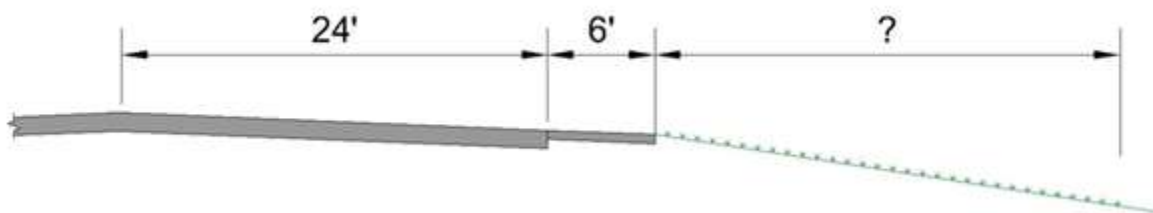

FIND:

An appropriate filter strip to treat runoff from the proposed roadway.

SOLUTION:

Due to the fact that stormwater runoff drained via sheet flow directly to the filter strip and the filter strip was the same width as the roadway segment length. Table 10.6.1-1 could be utilized. By looking up the pavement width and slope, the designer comes the solution of 21 feet.

Filter Strip Length for Select Applications						
Pavement Width (ft)	Filter Strip Length (ft)					
	Slope 4:1	Slope 6:1	Slope 8:1	Slope 6%	Slope 4%	Slope 2%
12	25	22	20	16	15	15
...						
30	36	32	29	23	21	17
...						
60	48	42	39	31	27	22

Summary

10.6.2 Grass Channel



Advantages	Disadvantages
<ul style="list-style-type: none"> • Lower cost • Reduction of impervious area • Well suited for linear environment • Stormwater collection and conveyance • Aesthetic benefits 	<ul style="list-style-type: none"> • Drainage area, flow velocity, and flow depth limitations • Must be used in series with other BMPs for removal credit • Design heavily dependent on existing site conditions and topography

Description: A vegetated channel designed to enhance water quality through the settling of suspended solids.

Design Considerations:

- Contributing drainage area less than 5 acres
- Water quality rainfall event flow velocity less than 1.0 ft/s and flow depth less than 4 inches
- Minimum residence time of 5 minutes
- Recommended slope between 1% and 2% with a maximum of 4%.
- Side slopes 3:1 or flatter
- Minimum 2-foot clearance from groundwater

Construction Considerations

- Before permanent grass has been established in the channel, bare soil within the channel is susceptible to erosion and scour. Any bare earth should be protected with TRM.

Maintenance Considerations:

- Provide adequate access to the BMP and appropriate components.

Applicability for Roadway Projects:

- Well suited for linear environments, interchanges, and facilities
- May be contained within the roadway right-of-way

Stormwater Management Suitability:

- Runoff Reduction
- Water Quality
- Channel Protection
- Overbank Flood Protection
- Extreme Flood Protection

✓ Suitable for this practice ○ May provide partial benefits ✗ Not suitable

LID/GI Considerations

When properly incorporated into overall site design, grass channels may reduce impervious cover, partially infiltrate runoff with pervious soils, complement the natural landscape, and render aesthetic benefits.

Treatment Capabilities

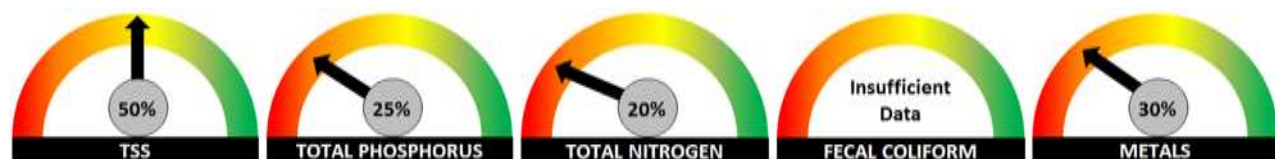

10.6.2 Grass Channel

Description

Grass channels, a form of a “biofilter,” are trapezoidal or parabolic shaped vegetated channels that work as a vegetative filter designed to enhance water quality through the settling of suspended solids through filtration, infiltration, and biofiltration. Grass channels also assist in meeting runoff velocity targets for the water-quality design storm of small drainage areas. (10-17) By reducing flow velocity, grass channels promote sedimentation, infiltration, and runoff attenuation. (10-26) Only vegetative filters provide an acceptable pollution management measure while conveying stormwater runoff. These vegetative filters include: waterways, ditches or swales, filter strips, and grass channels. A grass channel may serve as a runoff collection and conveyance system by acting as a single BMP, pretreatment BMP to another BMP, and/or as a link between other measures. Grass channels are limited to small drainage areas (less than 5 acres) and are well suited for incorporation into many applications and land uses, including linear roadway environments. They are considered an LID and GI practice and may also provide aesthetic benefits by accenting the natural landscape.

Grass channels differ from traditional roadside ditches in that grass channels, designed for water quality purposes, promote increased residence time and decreased conveyance velocity for the water-quality design storm. Grass channel design should provide a sufficient channel length to attain a minimum residence time of 5 minutes, while runoff velocity within the channel should not exceed 1.0 ft/s for the water quality design rainfall event peak discharge. (10-17) Water quality benefits are typically achieved by broadening base widths, lowering slopes, and creating dense vegetation. In areas with permeable soil, grass channels may also partially infiltrate runoff from small storm events, reducing runoff volume. A typical grass channel configuration is illustrated in Figure 10.6.2-1.

Figure 10.6.2-1 - Typical grass channel configuration



Stormwater Management Suitability

- **Runoff Reduction** – Grass channels provide partial runoff reduction benefits. They become more effective the higher the infiltration rate of the native soils. A grass channel can be designed to provide 25% of the runoff reduction volume for type A and B hydrologic soils or 10% of the runoff reduction volume for type C and D hydrologic soils. Performance is dependent on vegetation density and contact time for settling, filtration, and infiltration.
- **Water Quality** – Grass channels can be used to remove a variety of pollutants from stormwater runoff. They are typically used as the pre-treatment component of a larger “treatment train” to reduce incoming runoff velocities and filter out particulates. A grass channel provides 50% TSS removal if designed, constructed, and maintained correctly. Either another BMP should be used in a treatment train with the grass channel or the grass channel can be sized for over-conveyance to provide the additional required water quality treatment. Because grass channels are typically situated along the length of a roadway, they may intercept additional drainage area and not just the new impervious surface. GDOT’s water quality volume, however, is calculated based on the new impervious area only. If there is sufficient existing impervious area in the basin, the grass channel can be sized to for a larger impervious surface area, increasing the overall BMP TSS removal, and meeting GDOT’s water quality requirement of 80% TSS removal from new impervious area. This can be achieved if the impervious area treated is at least 1.6 times the new impervious area. For example, if the calculated target water quality volume is 5,000 ft³, the grass channel can be sized to include 8,000 ft³ of water quality volume and meet the 80% TSS removal requirement (8,000 ft³ * 50% TSS removal = 5,000 ft³ * 80% TSS removal).
- **Channel Protection** – For smaller sites, a grass channel may be designed to capture the entire channel protection volume (CP_v). Given that a grass channel is typically designed to completely drain over 48-72 hours, the requirement of extended detention for the 1-year, 24-hour storm runoff volume will be met. For larger sites, or where only the WQ_v is diverted to the grass channel, another control must be used to provide CP_v extended detention.
- **Overbank Flood Protection** – Another control will likely be required in conjunction with a grass channel to reduce the post-development peak flow of the 25-year storm (Q_{p25}) to pre-development levels (detention).
- **Extreme Flood Protection** – Grass channels must provide flow diversion and/or be designed to safely pass extreme storm flows while protecting vegetation.

Pollutant Removal Capabilities

The following average pollutant removal rates may be utilized for design purposes: [\(10-17\)](#)

- TSS – 50%
- TP – 25%
- TN – 20%
- Fecal Coliform – insufficient data
- Heavy Metals – 30%

Water quality benefits may be maximized when the channels are designed in series with other structural stormwater controls.

Application and Site Suitability

Grass channels are a low-cost option appropriate for various transportation applications, including linear roadways, interchanges, and facilities. Grass channels are not intended for runoff attenuation and should not act as a singular BMP when flooding is a concern.

Channel location and configuration will be largely dependent upon the contours of the land adjacent to a roadway alignment, the available right-of-way, and the results of the hydraulic analysis. Channels should not be placed within the limits of delineated wetlands. The final location should be coordinated with the project environmentalist to ensure compliance with the approved environmental document. Siting information and constraints include the following:

- **Drainage Area** – Maximum contributing drainage area of 5 acres. If the practice is used on larger drainage areas, the flows and volumes through the channel become too large to allow for filtering and infiltration of runoff.
- **Side Slope** – Slopes of the channel should be 3:1 or flatter.
- **Longitudinal Slope** – Between 1-4%; slopes between 1-2% are recommended.
- **Base Width** – The maximum width of a grass channel is a function of the regional geology in order to control stream braiding within channels. Braiding develops more easily in loose, incoherent soils (sands and glacial till, etc.). Cohesive soils (e.g., saprolite) are more resistant to braiding, so the maximum channel width may be greater. Therefore, the maximum channel width is 6 feet for the Georgia Coastal Plain (Upper and Lower Coastal Plain) and 10 feet for all other regions of Georgia.
- **Minimum Depth to Water Table** – A minimum of 2 feet is required between the channel bottom and the seasonal high groundwater table.
- **Runoff Velocities** – Must not be erosive. The maximum velocity of the water quality peak flow is 1.0 ft/s.
- **Flow Depth** – The maximum flow depth of the water quality peak flow is 4 inches.
- **Residence Time** – A minimum 5-minute residence time is required for the water quality peak flow. Residence time may be increased by reducing the slope of the channel, increasing the wetted perimeter, planting a denser grass, or installing check dams.
- **Soils** – No restrictions, although grass channels located on permeable soils (i.e., hydrologic soil group A or B soils) provide greater stormwater management benefits.

A stable channel is the ultimate goal for all channels located within a highway right-of-way or that impact highway facilities. A stable channel is a densely vegetated channel capable of withstanding erosion from the stormwater runoff. In addition to water quality design specifications, grass channel design is also required to comply with hydraulic design and freeboard requirements of the open channel design policy, as outlined in chapter 5 of this manual.

Figure 10.6.2-2 - Typical grass channel configuration

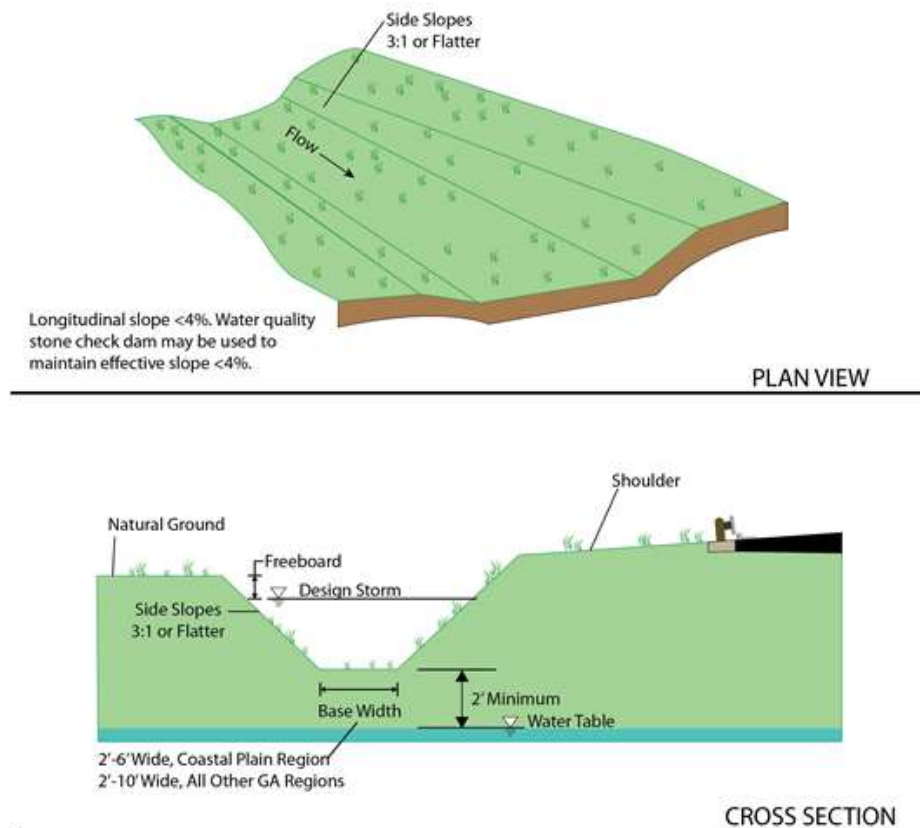

Data for Design

The initial data for grass channel design may include the following:

- Existing and proposed site, topographic and location maps, and field reviews
- Field measured topography or digital terrain model (DTM)
- Soils data from the NRCS Web Soil Survey or other source
- Aerial/site photographs
- Drainage basin characteristics
- Preliminary plans including plan view, roadway and drainage profiles, cross sections, utility plans, and soil report
- Environmental constraints
- Design data of nearby structures (storm sewer as built information)
- Additional survey information

Vegetation

The type of grass selected should be a dense variety that can withstand relatively high velocity flows and both wet and dry periods. To maximize water quality benefits, the grass should be as dense as possible. A list of grass varieties appropriate for use in Georgia can be found in GDOT specification section 700.

Additional Design Considerations

Water quality benefits may be enhanced through the use of permanent check dams at pipe inflow points and at various other points along the grass channel. Refer to the Check Dams Special Construction Detail for more information, including clear zone considerations.

The grass channel design must also adequately convey runoff from design storms as established based on roadway, traffic, site, and safety parameters and stated in the GDOT open channel design policy. Additional design considerations include compliance with regulatory agencies, freeboard, channel lining, energy dissipation, and outlet protection. Refer to chapter 5 of this manual for the Open Channel Design Policy.

Grass Channel Sizing

1. Determine the goals and primary function of the grass channel.

The goals and primary function of the BMP must take into account any restrictions or site-specific constraints. Also take into consideration any special surface water or watershed requirements.

- A grass channel must be designed for the water quality volume. The grass channel, however, can provide some runoff reduction benefit and reduce the required detention volume downstream. To calculate the RR_v credited for the practice (sized for WQ_v), Steps 2 – 8 have to be met, then proceed to Step 9. Otherwise the design process ends with Step 8.

2. Determine if the development site and conditions are appropriate for the use of a grass channel.

Consider the application and site feasibility criteria in this section to determine if site conditions are suitable for a grass channel.

3. Calculate the Target Water Quality Volume.

Calculate the water quality volume formula using the following formula:

$$WQ_v = \frac{1.2 \text{ in} \times (R_v) \times A \times 43560 \frac{\text{ft}^2}{\text{acre}}}{12 \frac{\text{in}}{\text{ft}}}$$

Where:

WQ_v = water quality volume (ft³)

R_v = volumetric runoff coefficient. See section 10.4 for volumetric runoff coefficient calculations.

A = the contributing onsite drainage area with proposed land use classifications draining to the most downstream segment of the grass channel (acres)

4. Calculate the water quality volume peak flow.

Calculate the water quality volume peak flow using the following formula and guidance in section 10.4.1.2.1.

$$Q_{wq} = q_u \times A \times Q_{wv}$$

Where:

Q_{wq} = water quality volume peak flow (ft³/s)

q_u = unit peak discharge (ft³/s /mi²/inch)

A = drainage area (mi²)

Q_{wv} = water quality volume expressed in inches (use 1.2R_v)

5. Determine channel geometry that meets the design requirements for the WQ_v storm event.

If calculating manually, use minimum channel geometry requirements, Manning's Equation, the Continuity Equation, and channel design charts found in HDS-3 [\(5-4\)](#) to begin the iterative computation process (see chapter 5 of this manual for more information). An alternative solution is to utilize computer software to design the channel that meets design requirements for the WQ_v storm event. Modify base width value and channel slope until the flow depth is less than 4 inches and the flow velocity is less than 1 ft/s.

6. Calculate the minimum length of the grass channel using a 5-minute residence time.

To calculate the minimum length (feet) of the grass channel using a 5-minute residence time, use Equation 10.6.2-1, shown below. In situations where the minimum length required is longer than what the site allows, consider using stone check dams to increase the residence time over a shorter length. For more information on this type of design, see Volume II of the GSMM. [\(10-17\)](#)

$$L = V \times (5 \text{ minutes}) \times \left(\frac{60 \text{ seconds}}{1 \text{ minute}} \right) \quad (10.6.2- 1)$$

Where:

L = minimum length of channel (ft)

V = velocity through the channel using the water quality volume peak flow (Q_{wq}) (ft/s)

7. Confirm the channel can pass all design requirements with required freeboard.

Refer to chapter 5 for freeboard requirements.

8. Calculate the runoff reduction volume conveyed to the practice.

$$RR_v = \frac{1 \text{ in} \times (R_v) \times A \times 43560 \frac{\text{ft}^2}{\text{acre}}}{12 \frac{\text{in}}{\text{ft}}}$$

Where:

RR_v = runoff reduction volume (ft³)

A = area draining to this practice (acres)

R_v = volumetric runoff coefficient. See section 10.4 for volumetric runoff coefficient calculations.

9. Calculate the runoff reduction volume credited.

Using Table 10.5-1 - *GDOT BMPs and Associated Pollutant Removals*, lookup the appropriate runoff reduction percentage (or credit) provided by the practice:

$$RR_v(\text{credited}) = RR_v(RR\%)$$

Where:

$RR_v(\text{credited})$ = runoff reduction volume provided by this practice (ft³)

RR_v = runoff reduction volume conveyed to this practice (ft³)

$RR\%$ = runoff reduction percentage, or credit, assigned to the specific practice

Maintenance Considerations

Without proper maintenance, BMPs will function at a reduced capacity and may cease to function altogether. A properly designed BMP takes into account access for maintenance:

- Provide adequate right-of-way or easement.
- Provide access roads and ramps for appropriate equipment to all applicable BMP components.
- Provide space to turn around if necessary.
- Check for sufficient area to safely exit and enter the highway, if applicable.

Refer to GDOT's *Stormwater System Inspection and Maintenance Manual*, for specific maintenance requirements.

Grass Channel Example Calculation

GIVEN:

- A new roadway project located in Dallas, Georgia.
- The proposed project includes 1,300 feet of roadway (in length).
- The drainage area that discharges to the grass channel includes the following: two 12-foot lanes, a 6-foot paved shoulder, and a 20-foot wide grassed area, draining via sheet flow.
- Assume no stormwater is collected as “off-site” or “bypass” runoff.
- Assume that the existing ground and available right-of-way is sufficient for a grass channel with a longitudinal slope of 1% and length of 1,300 feet.
- The designer has previously calculated the following hydrologic information:
 - $RR_v = 3,195 \text{ ft}^3$
 - $WQ_v = 3,835 \text{ ft}^3$
 - $Q_{wq} = 1.10 \text{ ft}^3/\text{s}$
 - $Q_{p25} = 6.77 \text{ ft}^3/\text{s}$

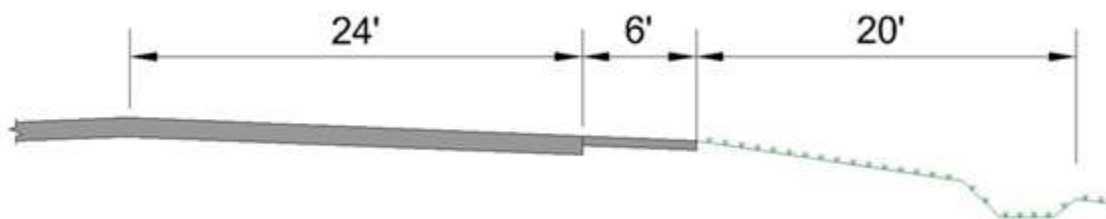

FIND:

- Size the grass channel to meet design requirements for the WQ_v flow and to safely convey the peak flow from the design storm event (25-year).

SOLUTION:

1. Determine if it is necessary to calculate the runoff reduction volume credited for the practice in order to reduce the detention volume requirements downstream. For this example, the runoff reduction volume credited will be calculated.
2. Based on the existing ground geometry, a grass channel with a longitudinal slope of 1.0% is appropriate for the site.
3. The water quality volume was already calculated to be $3,835 \text{ ft}^3$.
4. The water quality volume peak flow was already calculated to be $1.10 \text{ ft}^3/\text{s}$.
5. Based on the existing ground geometry, the grass channel will utilize a longitudinal slope of 1.0%. If calculating manually, use minimum channel geometry requirements, Manning's Equation, the Continuity Equation, and channel design charts found in HDS-3 (5-4) to begin the iterative computation process (see chapter 5 of this manual for more information). An

alternative solution is to utilize computer software to design the channel that meets design requirements for the WQ_v storm event.

$$Q_{wq} = 1.10 \text{ ft}^3/\text{s}$$

Manning's $n = 0.24$ (densely vegetated grass swale)

Computer Software Iteration 1:

- Given: Longitudinal slope = 1.0% (0.01 ft/ft)
- Assume: Base width = 2 ft
- Assume: Side slopes = 3:1
 - Flow depth = 8.64 inches (0.72 ft) **> 4 inches Too High**
 - Flow velocity = 0.4 ft/sec **< 1 ft/sec. OK**

Adjust channel dimensions and longitudinal slope as needed until flow depth and velocity are satisfactory.

Computer Software Iteration 2:

- Given: Longitudinal slope = 1.0% (0.01 ft/ft)
- Assume: Base width = 8 ft
- Assume: Side Slopes = 6:1
 - Flow depth = 4.56 inches (0.38 ft) **> 4 inches Too High**
 - Flow velocity = 0.3 ft/sec **< 1 ft/sec. OK**

Computer Software Iteration 3:

- Given: Longitudinal slope = 1.0% (0.01 ft/ft)
 - Assume: Base width = 10 ft
 - Assume: Side Slopes = 8:1
 - Flow depth = 4 inches (0.33 ft) **≤ 4 inches OK**
 - Flow velocity = 0.26 ft/sec **≤ 1 ft/sec. OK**
6. Verify the length available meets the minimum length of the grass channel calculated using a 5-minute residence time.

$$L = V \times (5 \text{ minutes}) \times \left(\frac{60 \text{ seconds}}{1 \text{ minute}} \right) = 0.26 \times 5 \times 60 = 78 \text{ ft}$$

Therefore, the 1,300 feet available for the length of the grass channel is sufficient.

7. Next, verify that channel design meets all design requirements as outlined in the design requirements of this section. Use Q_{p25} in the same manner as above to determine channel depth and verify stable channel design for the design storm event.

$$Q_{p25} = 6.77 \text{ ft}^3/\text{s}$$

- Flow depth = 11 inches (0.88 ft)

- Flow velocity = 0.45 ft/sec **Non-erosive (less than 4 ft/sec) OK**

Add 0.5 feet to the flow depth for freeboard to get overall channel depth equal to 1.38 feet. Set channel to minimum to a depth of 1.5 feet.

Adjust channel dimensions as needed for stable channel design and existing site conditions. If channel dimensions are modified, re-calculate flow depth and velocity values for WQ_v and the design storm event. Repeat until flow depth and velocity meet design requirements for both the WQ_v and the design storm event.

Verify that channel design meets all design requirements as outlined in the open channel design policy as outlined in chapter 5.

The design could end at this step, but if a designer wants to determine the runoff reduction volume credited by the practice, continue to step 8.

8. The water quality volume was already calculated to be 3,195 ft³.
9. Calculate the runoff reduction volume credited. A grass channel with HSG B soils is credited with 25% runoff reduction.

$$RR_v(\text{credited}) = RR_v(\text{RR}\%)$$

$$RR_v(\text{credited}) = 3,195 \times (25\%) = 799 \text{ ft}^3$$

Summary

10.6.3 Enhanced Swale



Description: A vegetated open channel designed and constructed to capture and treat stormwater runoff from the WQ_v rainfall event in dry or wet cells formed by check dams or other means.

Design Considerations:

- Drainage area less than 5 acres
- Longitudinal slope less than 4% with 1% to 2% recommended
- Maximum 18 inches WQ_v ponding depth
- Side slopes of 4:1 or flatter recommended, max 2:1
- Maintain non-erosive velocity for 2-year storm
- Dry swale has multiple underdrain options that provide different runoff reduction credits

Maintenance Considerations:

- Provide adequate access to the BMP and appropriate components.
- Maintaining the vegetative cover is essential to the proper operation of the enhanced swale.

Advantages	Disadvantages
<ul style="list-style-type: none"> • Water quality benefits • Can be configured to provide stormwater attenuation • Design options suitable for dry or wet conditions • No soil restriction • Moderate maintenance burden 	<ul style="list-style-type: none"> • Potential large land requirement • Limited to small drainage areas • Unsuitable for steep terrains • Moderate capital cost • Potential for odor or mosquitos with wet swale

Applicability for Roadway Projects:

- Space and grade requirements may limit applicability in the linear environment.
- Channel shape can be elongated to accommodate roadway applications.
- Check dams serve as a design option when existing slopes are too steep.

Stormwater Management Suitability:

- Runoff Reduction
 - Water Quality
 - Channel Protection
 - Overbank Flood Protection
 - Extreme Flood Protection
- Suitable for this practice
 May provide partial benefits
 Not suitable

LID/GI Considerations

Enhanced swales are considered a LID/GI design practice and may be eligible for low impact development credit. They are capable of blending in with and enhancing the natural landscape.

Treatment Capabilities



10.6.3 Enhanced Swale

Description

Enhanced swales are vegetated open channels designed and constructed to capture and treat stormwater runoff from the water quality rainfall event that collects within a dry or wet cell formed by an outlet control structure or other means. Enhanced swales are a structural BMP and considered an LID/GI practice. The incorporation of specific design features to enhance stormwater pollutant removal effectiveness distinguishes the enhanced swale from a normal drainage ditch or grass channel.

The enhanced swale operates much like a grass channel in that it is a trapezoidal or parabolic-shaped vegetated channel used as a measure for runoff conveyance and attenuation. Enhanced swales work as a type of vegetative filter designed to enhance water quality through the settling of suspended solids through filtration, infiltration, and biofiltration. The enhanced swale additionally incorporates the use of an outlet control structure to retain the water quality volume and promote settling and infiltration.

The two primary enhanced swale designs include:

- **Enhanced Dry Swale** – Includes a filter media of soil and an underdrain system designed to treat the water quality volume through filtration and infiltration. The mostly dry conditions of the dry swale make it the preferred option in areas where standing water may present a safety hazard.
- **Enhanced Wet Swale** – Designed to retain the water quality volume in support of wetland vegetation, wet swales achieve pollutant removal from the water quality volume through sediment accumulation and biological removal. Wet swales are better suited for areas with a high water table or poorly draining soils.

Figure 10.6.3-1 shows examples of both dry and wet swales.

Figure 10.6.3-1 - Enhanced swale examples [\(10-17\)](#)



Enhanced Dry Swale



Enhanced Wet Swale

Enhanced swales are designed primarily for stormwater quality and have limited ability in channel protection and conveyance. Enhanced swales are best suited for small drainage areas (less than 5 acres), well suited for incorporation into many applications and land uses, including linear roadway environments, and may also provide aesthetic benefits by accenting the natural landscape.

Stormwater Management Suitability

- Runoff Reduction – Dry swales with a capped or closed underdrain can be designed to provide 100% of the runoff reduction volume, if properly maintained. A dry swale can also be designed with an open underdrain to provide 50% of the runoff reduction volume, if properly maintained. Enhanced wet swales do not provide runoff reduction volume credits.
- Water Quality – Dry swale systems rely primarily on filtration through an engineered media and/or infiltration into the underlying soils to provide removal of stormwater contaminants. Both the enhanced dry swale and enhanced wet swale provide 80% TSS removal if designed, constructed, and maintained correctly.
- Channel Protection – Generally, only the WQ_v is treated by a dry or wet swale, and another BMP must be used to provide CP_v extended detention. However, for some smaller sites, a swale may be designed to capture and detain the full CP_v .
- Overbank Flood Protection – Enhanced swales must provide flow diversion and/or be designed to safely pass overbank flood flows. Ensure non-erosive velocities for the 25-year event or the 50-year event if the swale is in a sag and armor 1' above this level. Another BMP must be used in conjunction with an enhanced swale system to reduce the post-development peak flow of the 25-year storm (Q_{p25}) to pre-development levels (detention).
- Extreme Flood Protection – Enhanced swales must provide flow diversion and/or be designed to safely pass extreme storm flows. The swale should be sized such that the 100-year storm can pass within the emergency spillway without overtopping the swale in any other location. Another BMP must be used in conjunction with an enhanced swale system to reduce the post-development peak flow of the 100-year storm (Q_f) if necessary.

Pollutant Removal Capabilities

Enhanced dry swales with a capped underdrain system are credited with a 100% pollutant removal capability. The following average pollutant removal rates may be utilized for enhanced swales with an open underdrain: [\(10-17\)](#)

- TSS – 80%
- TP – 50% (Dry Swale) / 25% (Wet Swale)
- TN – 50% (Dry Swale) / 40% (Wet Swale)
- Fecal Coliform – insufficient data
- Heavy Metals – 40% (Dry Swale) / 20% (Wet Swale)

Stability is the ultimate goal for all swales located within a highway right-of-way or that impact highway facilities. In addition to water quality design requirements, enhanced swale design is also required to comply with the hydraulic design and freeboard requirements of the Open Channel Design Policy, as outlined in chapter 5 of this manual.

Application and Site Suitability

Enhanced swales are a moderate cost option appropriate for various transportation applications, including roadways, highways, and non-road areas with a low percentage of impervious cover. The relatively large land requirement limits the incorporation of enhanced swales in high density areas or where a right-of-way may be limited.

Dry swales tend to be more prevalent along rural primary roads and highways. Wet swales generally are not the preferred BMP in high density or urban areas due to the presence of standing water and the potential safety threat, odor, or mosquitos. Wet swales may be used along highways as an element of a landscaped area.

Location and configuration will be largely dependent upon the existing site conditions, the available right-of-way, and the results of a hydraulic analysis. Location and geometry should be determined on a case-by-case basis using sound engineering judgment. The final location should be coordinated with the project environmentalist to ensure compliance with the approved environmental document.

Earth check dams, and/or enhanced swale outlet structures shall not be placed in the median. Additionally, earth check dams and/or enhanced swale outlet structures shall not be placed in the clear zone. Guardrail shall not be placed solely for the purpose of placing any combination of earth check dams and/or enhanced swale outlet structures.

When considering locations for enhanced swales, the following constraints should be considered:

- **Drainage Area** - Contributing drainage area should be less than 5 acres.
- **Space Required** - Enhanced swale design generally requires a surface area equal to approximately 10% to 20% of the contributing impervious area.
- **Depth to Water Table** –
 - The bottom of the underdrain layer should be a minimum of 2 feet above the seasonal high groundwater table for dry swales.
 - A wet swale can be used where the water table is at or near the soil surface, or where there is a sufficient water balance in poorly drained soils to support a wetland plant community. If above an aquifer or treating a hotspot, however, 2 feet is required between the bottom of a wet swale and the elevation of the seasonally high water table. Where wet swales do not intercept the groundwater table, a liner must be installed on HSG A and B soils. A water balance calculation should be performed to ensure an adequate water budget to support the specified wetland species. A water balance analysis may not be necessary if a liner is installed but should be considered regardless if the drainage area is small and/or has a small amount of impervious area. The wet swale size may need to be adjusted to account for lost volume due to seasonal fluctuations in the groundwater table.
- **Trout Stream** – Runoff temperature reduction is provided when an enhanced dry swale is designed for infiltration. If discharging to a trout stream where temperature is a concern, evaluate for stream warming when an open underdrain system is used.

- **Aquifer Protection** - No exfiltration of hotspot runoff from dry swales is allowed in areas subject to aquifer protection. An impermeable liner should be used, or an infiltration BMP should be avoided in these areas.
- **Airports** - A wet swale should not be located within 5 miles of a public-use airport.

Data for Design

The initial data needed for enhanced swale design may include the following:

- Existing and proposed site, topographic, location maps, and field reviews
- Field measured topography or digital terrain model (DTM)
- Aerial/site photographs
- Drainage basin characteristics
- Preliminary plans including plan view, roadway and drainage profiles, cross sections, utility plans, and soil report
- Environmental constraints
- Design data of nearby structures
- Additional survey information
- Depth to seasonally high groundwater
- Soils data from the Web Soil Survey or other source.

General Design Criteria

After initial data gathering, the contributing drainage area should be delineated, and the post-project land use should be used to compute the peak flow of the WQ_v (see section 10.4.1.2) draining to the most downstream segment of the enhanced swale.

Next, preliminary values for swale size and slope should be determined. Location and general configuration for the enhanced swale should account for aesthetics and be preliminarily set based on the following design criteria:

- **Slope** – Longitudinal channel slopes between 1% and 2% are recommended. Maximum slope is 4%. Six-inch or 12-inch check dam may be used at minimum 50-foot spacing when needed. Longitudinal slope between 1% and 4% for enhanced dry swales.
- **Base Width** – The minimum base width is 2 feet, and the maximum base width is 8 feet.
- **Side Slope** – The maximum side slope is 2:1.
- **Runoff Velocity** – Maintain non-erosive velocity (less than 4 feet per second) within the swale for the 25-year storm event.

The design elements specific to an enhanced dry swale are discussed below and illustrated in Figure 10.6.3-2.

Figure 10.6.3-2 - Enhanced Dry Swale schematic

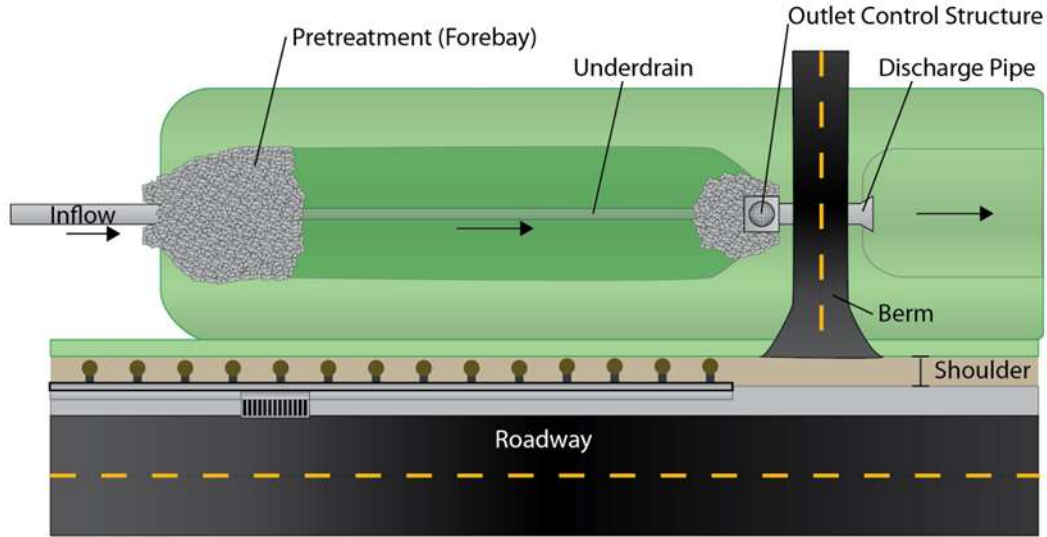

PLAN VIEW

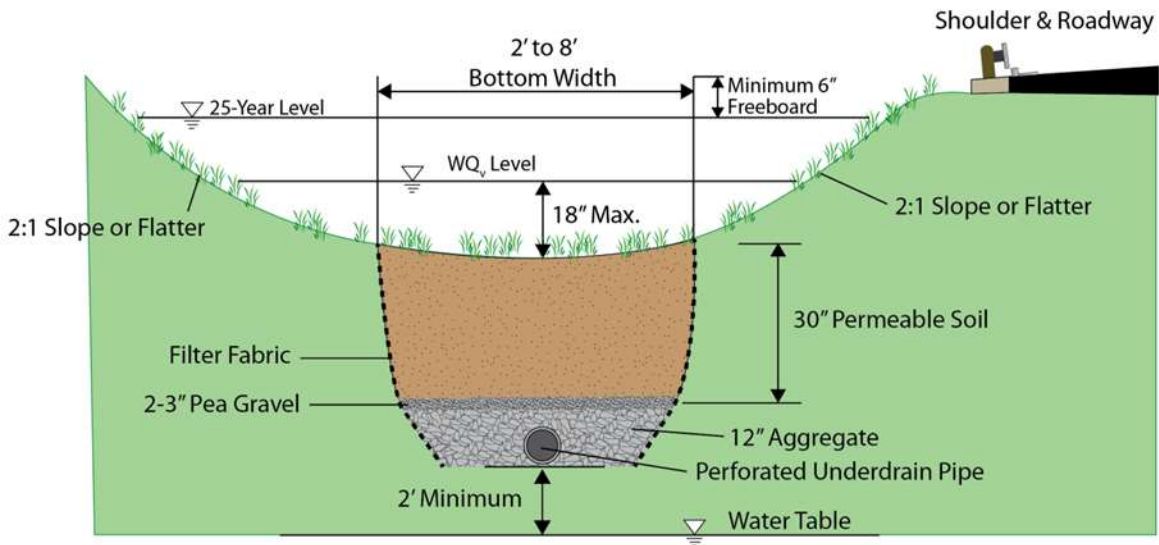

CROSS SECTION

Pretreatment

Pretreatment of runoff in both a dry and wet swale system is typically provided by a sediment forebay located at the inlet. Vegetated filter strips and gentle side slopes should be provided along the top of channels to provide pretreatment for lateral sheet flows.

Filter Media

The required treatment is achieved as the WQ_v flows through the filter media and potentially infiltrates into the underlying soil. The surface area of the filter media is designed such that the WQ_v has a maximum drawdown time of 48 hours.

- Refer to GDOT Special Provision 169.
- Minimum soil media infiltration rate (coefficient of permeability) of 2 ft/day.
- Where possible, soil media is recommended to contain a high level of organic material to promote pollutant removal.
- Sod should be obtained from a supplier that grows in nonclay soils where possible. Sod grown in clayey soils can reduce infiltration into the media, causing the basin to retain water longer than desired. Generally, sod should be 'half cut' or 'thin cut' whereby the soil thickness is approximately half of conventionally available sod to maximize infiltration. [\(10-26\)](#)

Underdrain

An underdrain system is only required for enhanced dry swales.

- Underdrain systems consist of a polyethylene pipe longitudinal underdrain, typically 8 inches in diameter in a 12-inch No. 57 aggregate layer.
- Outlet protection must be used at any discharge point to prevent scour and downstream erosion. Discharge underdrain systems to storm drainage infrastructure or stable outlet.
- Refer to section 10.8.3 of this manual and the GDOT Underdrain Special Construction Detail for additional information regarding underdrain design.

Outlet Control Structure

- There are three potential outlet control structure configurations for the enhanced dry swale: retaining wall outlet, earth berm outlet and concrete drop inlet. Refer to the Enhanced Dry Swale Outlet Structure Special Construction Detail.
- The outlet control structure is designed to both retain the WQ_v in the BMP, as well as safely convey the remaining runoff downstream of the enhanced dry swale.
- The overflow weir is placed at the elevation of the WQ_v , which is a maximum of 18-inches above the bottom of the swale. The overflow weir allows the runoff that does not filter through the media to discharge from the BMP and be conveyed downstream.
- The length of the overflow weir is designed to allow the enhanced swale to safely pass the 25-year, 24-hour storm event with a minimum 6 inches of freeboard.

The following weir equation is used to determine weir length of a broad-crested weir. [\(10-32\)](#)

$$Q = C_d \times L \times H^{\frac{3}{2}}$$

(10.6.3- 2)

Where:

Q = Peak flow (ft³/s)

C_d = Weir coefficient

L = Length of weir (ft)
 H = Depth of water above weir crest (ft)

The 100-year storm should pass within the emergency spillway without overtopping the swale in any other location. Ensure non-erosive velocities for the 25-year event or the 50-year event if the swale is in a sag and armor 1' above this level.

Check Dams

In areas where the surrounding terrain is too steep to maintain 1% to 4% swale slopes, check dams may be incorporated into the design to flatten out sections of the swale. Check dams should be sized/spaced to contain and distribute the design volume across the length of the channel. If utilized, proper outlet and energy dissipation is required to prevent the erosion or failure of the downstream swale adjacent to the check dam. Refer to the Check Dams Special Construction Detail for more information. An example profile of an enhanced dry swale with check dams is shown in Figure 10.6.3-3.

Figure 10.6.3-3 - Example profile utilizing check dams

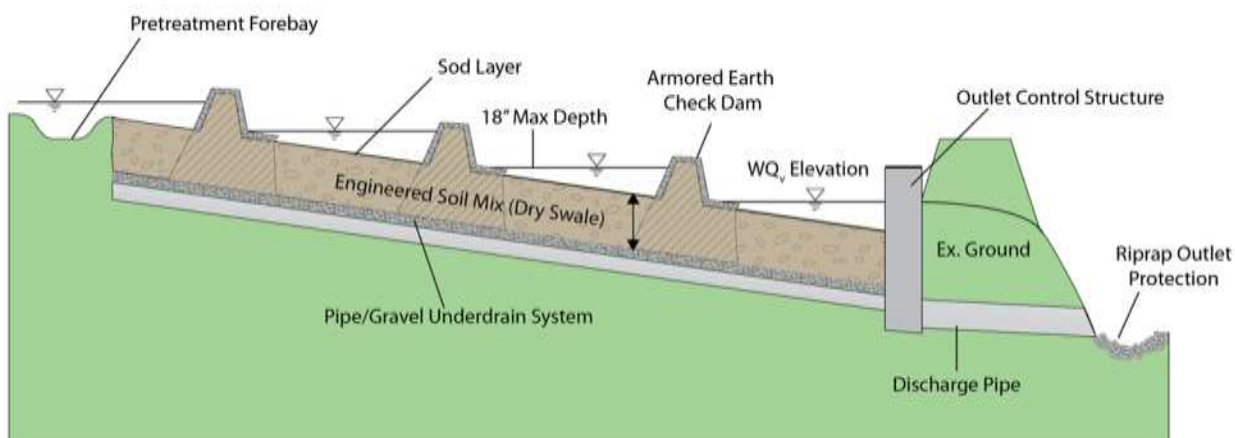

Access and Driveway Considerations

Adequate access to all elements of the enhanced swale should be included in the design to allow for inspection and maintenance. Driveway crossings can also be located within the limits of the dry enhanced swale, as long as the effective surface area of the filter media is adjusted to account for the driveway.

Enhanced Dry Swale Sizing

1. Determine the goals and primary function of the enhanced dry swale.

The goals and primary function of the BMP must take into account any restrictions or site-specific constraints. Also take into consideration any special surface water or watershed requirements.

- Use the NRCS web soil survey to find the HSG where the BMP would be located. If the enhanced dry swale would be located in HSG A or B, use Worksheet J-1 to determine if infiltration is potentially suitable. Based on this, indicate on the plans if construction will need to perform infiltration testing. Enhanced dry swales are sized for the WQ_v because the WQ_v is greater than the RR_v. If construction determines that the swale will be capped, it will provide infiltration and retain the RR_v. However, it will be large enough to treat the WQ_v in case construction were to determine that the infiltration rate is not sufficient at the site.
- Consider if the BMP can be “oversized” to include the channel protection volume.
- Size flow diversion structure, if needed

2. Determine if the enhanced dry swale will be on-line or off-line. If the enhanced swale will be off-line, a flow regulator (or flow splitter diversion structure) should be supplied to divert the WQ_v, to the swale. The design storm peak flow is needed for sizing an off-line diversion structure. See section 10.8.2 for more information on bypass structures. See section 10.4.1.2 for more information on calculating the water quality volume peak flow.

3A. Calculate the Target Water Quality Volume.

Calculate the water quality volume formula using the following formula:

$$WQ_v = \frac{1.2 \text{ in} \times (R_v) \times A \times 43560 \frac{\text{ft}^2}{\text{acre}}}{12 \frac{\text{in}}{\text{ft}}}$$

Where:

WQ_v = water quality volume (ft³)

R_v = volumetric runoff coefficient. See section 10.4 for volumetric runoff coefficient calculations.

A = onsite drainage area of the post-condition basin (acres)

3B. Determine the storage volume of the practice and the pretreatment volume

The actual volume provided in the enhanced swale is calculated using the following formula:

$$VP = PV + VES(N_{ES}) + VA(N_A)$$

Where:

VP = volume provided (temporary storage)

PV = ponding volume

VES = volume of engineered soils

N_{ES} = porosity of engineered soil (For enhanced dry swales, use 0.25)

VA = volume of aggregate

N_A = porosity of aggregate (use 0.4)

Note that if the BMP is being sized for CP_v , the required storage volume for CP_v calculated per section 10.4.2 will replace the WQ_v in the formula above.

If check dams are needed use erosion control sediment storage calculation equation to find the ponding volume within each segment.

Provide pretreatment by using a grass filter strip, as needed (sheet flow), or a forebay (concentrated flow). Where filter strips are used, 100% of the runoff should flow across the filter strip. Pretreatment is also necessary to reduce flow velocities and assist in sediment removal and maintenance. Pretreatment can include a forebay, weir, or check dam. Splash blocks or level spreaders should be considered to dissipate concentrated stormwater runoff at the inlet and prevent scour. Forebays should be sized to contain 0.1 inches per impervious acre of contributing drainage.

3C. Verify total volume provided by the practice is at least equal to the $WQ_{v(target)}$.

When the $VP \geq WQ_{v(target)}$ then the runoff reduction requirements are met for this practice. When the $VP < WQ_{v(target)}$, then the design must be adjusted.

3D. Verify that the enhanced swale will drain in the specified timeframes.

The ponding volume of the enhanced dry swale must drain in less than 48 hours.

$$t_f = \frac{PV(d_f)}{k(h_f + d_f)A_f}$$

Where:

- t_f = drain time (days)
- PV = ponding volume (ft³)
- d_f = filter media depth (ft)
- k = hydraulic conductivity (2-4 ft/day)
- h_f = average water depth (ft)
- A_f = top surface area of filter media (ft²)

Note that if the BMP is being sized for CP_v , the required storage volume for CP_v calculated per section 10.4.2 will replace the WQ_v in the formula above.

4. Check 2-year and 25-year velocity erosion potential, if the BMP is online.

Check for erosive velocities and modify design as appropriate. Ensure non-erosive velocities for the 25-year event or the 50-year event if the swale is in a sag and armor 1' above this level.

5. Confirm the swale can pass all design requirements with required freeboard.

Refer to Chapter 5 for freeboard requirements.

6. Design outlet control structure and emergency overflow

An overflow must be provided to bypass and/or convey larger flows to the downstream drainage system or stabilized watercourse. The 100-year storm should pass within the emergency spillway without overtopping the swale in any other location. Non-erosive velocities need to be ensured at the outlet point.

Enhanced Dry Swale Example Calculation

GIVEN:

- A roadway widening project located in Savannah, Georgia.
- The proposed project includes 1,500 feet of roadway (in length).
- Approximately 325 feet is available for an enhanced dry swale; good vegetative cover can be established and maintained upgradient of the proposed BMP. Longitudinal slope of 1%.
- 20 feet of available width will be present in the typical section for installation of the enhanced dry swale.
- The site meets all other site constraints such that an enhanced dry swale is appropriate for use.
- HSG is A
- The designer has previously calculated the following hydrologic information:
 - $WQ_v = 4,312$ cuft

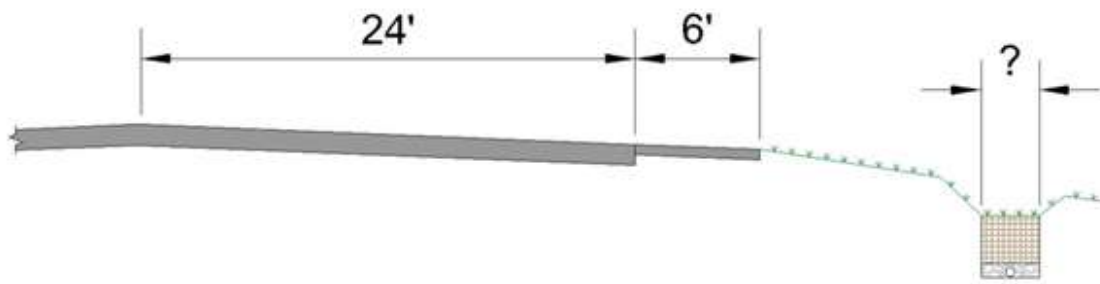

FIND:

- The enhanced dry swale size and configuration that meets the site constraints and treats the WQ_v .

SOLUTION:

1. Worksheet J-1 has been filled out and determined that having a capped enhanced dry swale is unsuitable. Note that if the design of the enhanced dry swale is feasible, the outlet structure should be left uncapped. Since the longitudinal slope is 1% and the check dam height is 1.5 ft, check dams will be added at least every 150 ft.
2. The water quality volume was already calculated as 4.312 cuft.
3. The next step is to determine the storage volume of the practice. To complete this step, use the area available as a starting point for the surface area of the enhanced dry swale. In this example, approximately 20 feet by 325 feet are available for the enhanced dry swale. It is recommended that a software program and/or BMP sizing calculator spreadsheet be used at this point. The volume provided by the BMP is calculated using the following formula:

$$VP = PV + VES(N_{ES}) + VA(N_A)$$

Where:

VP = volume provided (temporary storage)

PV = ponding volume

VES = volume of engineered soils

N_{ES} = porosity of engineered soil (For enhanced dry swales, use 0.25)

VA = volume of aggregate

N_A = porosity of aggregate (use 0.4)

Therefore, at least an estimate of the following values is required to calculate the storage volume of the BMP:

- Bottom width of the swale
- Engineered soil mix depth
- Aggregate layer depth

For the purposes of this example, the following values are used as a starting point for sizing the basin. A bottom width of 6.5 ft, 4:1 slopes, a 1% longitudinal slope, and 150 ft long segments:

Volume of ponding per segment:

$$(6.5 \text{ ft} \times 0.01 \times (150 \text{ ft})^2 \div 2) + \left((0.01)^2 \times \frac{(150 \text{ ft})^3}{6 \times 0.25} \right) + \left((0.01)^2 \times \frac{(150 \text{ ft})^3}{6 \times 0.25} \right) = 1181.25 \text{ cuft}$$

- Engineered soil mix depth = 30 inches = 2.5 ft
- Aggregate layer depth = 12 inches = 1 ft
- Solve for $VP = PV + VES(N_{ES}) + VA(N_A)$
 - $4,312 \text{ cuft} \leq (1,181.25 \text{ cuft} \times \# \text{ segments}) + (2.5 \text{ ft} \times 6.5 \text{ ft} \times \text{length} \times 0.25) + (6.5 \text{ ft} \times \text{length} \times 0.4)$
 - $\# \text{ segments} = \text{length} \div 150 \text{ ft}$
 - Solution is a swale of 300 ft length, providing 4,361 cuft of WQ_v

As a factor of safety, the void space in the No. 8/No. 89 layer is not part of the storage calculations. This additional volume can serve as a safety buffer for storage in heavy rainfall.

A forebay is the chosen pretreatment method for this enhanced dry swale. Forebays should be sized to contain 0.1 inches per impervious acre of contributing drainage. The required forebay volume is 404 ft³.

4. Verify the ponded volume will drain in less than 48 hours. .

$$t_f = \frac{PV(d_f)}{k(h_f + d_f)A_f}$$

Where:

A_f = top surface area of filter media (1,950 ft²)

P_v = ponding volume (2,362.5 ft³)

d_f = filter media depth (2.5 ft)

k = hydraulic conductivity (2 ft/day)

h_f = average water depth (0.75 ft)

t_f = drain time (days)

$$t_f = \frac{2,362.5(2.5)}{2(0.75 + 2.5)1,950} = 0.347 \text{ days} = 11.28 \text{ hours}$$

Additional design steps:

1. Check the 2-year and 25-year velocity erosion potential and freeboard.
2. Design outlet control structure and emergency overflow.
3. Size flow diversion structure, if needed.

Design Elements – Enhanced Wet Swale

An enhanced wet swale is designed to retain the WQ_v within the BMP in support of wetland vegetation. Wet swales achieve pollutant removal from the water quality volume through sediment accumulation and biological removal. Wet swales are sized to retain the entire WQ_v with less than 18 inches of ponding above the high water table at the maximum depth point. The outlet control structure in the wet swale includes an orifice that is sized to allow the WQ_v to draw down in a time frame less than 48 hours. Enhanced wet swales do not provide runoff reduction volume credits. The design elements specific to an enhanced wet swale are discussed below and illustrated in Figure 10.6.3-4.

Figure 10.6.3-4 - Enhanced wet swale schematic

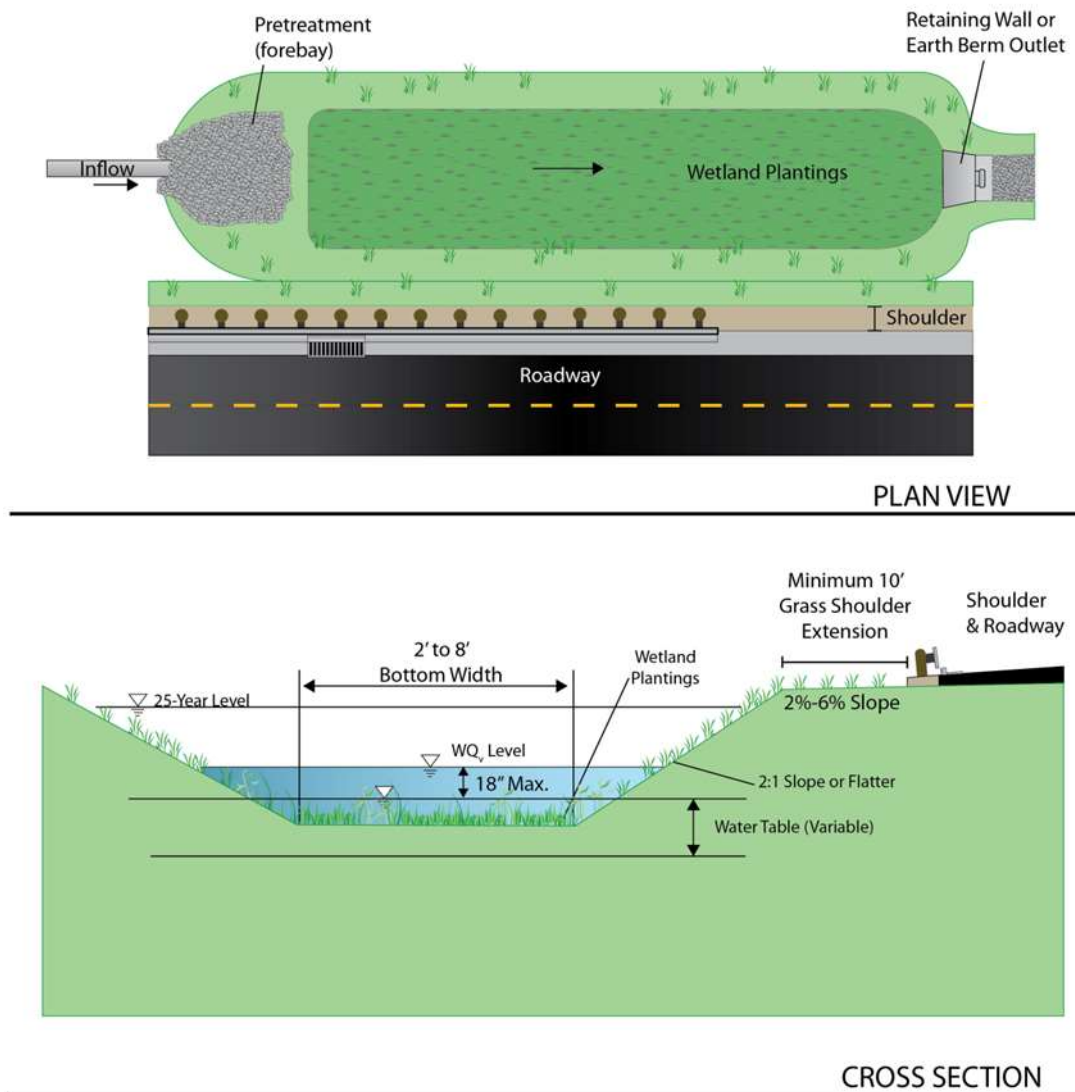

One design characteristic, unique to a wet enhanced swale, is the grass shoulder extension as shown in Figure 10.6.3-4. To prevent slope instability along the front slope of the wet swale, a minimum of

10 feet must be provided between the edge of pavement, or paved shoulder, and the slope of the wet enhanced swale.

Outlet Control Structure

A low flow orifice should be incorporated into the outlet structure to allow for the drainage of the water quality volume in less than 48 hours. The orifice elevation shall be a maximum of 18 inches above the high water table. The following orifice equation is used to determine the size of the orifice:

$$Q = C_d \times A \times (2gh)^{0.5} \quad (10.6.3- 3)$$

Where:

- Q = Peak flow (ft³/s)
- C_d = Orifice coefficient = 0.6
- A = Area of orifice (ft²)
- g = Gravitational constant (32.2 ft/sec²)
- h = Depth of water to center of orifice (ft)

In addition, an overflow weir should be designed to allow the enhanced wet swale to safely pass the 25-year, 24-hour storm event with a minimum 6 inches of freeboard. The following weir equation is used to determine weir length of a broad-crested weir. [\(10-32\)](#)

$$Q = C_d \times L \times H^{\frac{3}{2}} \quad (10.6.3- 4)$$

Where:

- Q = Peak flow (ft³/s)
- C_d = Weir coefficient = 2.6
- L = Length of weir (ft)
- H = Depth of water above weir crest (ft)

Finally, the outlet control structure or outlet conveyance channel must also be designed to adequately carry the extreme flood protection volume (100-year, 24-hour rainfall event). Refer to the Enhanced Wet Swale Outlet Structure Special Construction Detail for more information.

Water Balance

Enhanced wet swales must be designed to maintain a permanent pool. Install an impermeable liner if the enhanced wet swale is located on HSG A or B soils and the swale does not intercept the groundwater table. A water balance analysis should be performed for systems on HSG C and D soils. Refer to section 10.2.4 for water balance calculations.

Landscaping Plan

A landscaping plan should be included as part of the complete design for the enhanced wet swale. The landscaping plan should specify how the enhanced wet swale will be stabilized and vegetation established. It should specify proper grass and wetland plants based on specific site soils and hydric conditions. Refer to GDOT Planting Schedule Special Construction Detail and Supplemental Specification on Post Construction Stormwater BMP Items for more information.

Access and Driveway Considerations

Adequate access to all elements of the enhanced wet swale should be included in the design to allow for inspection and maintenance. Driveway crossings can also be located within the limits of the enhanced wet swale, as long as the WQ_v is adjusted to account for the driveway.

Enhanced Wet Swale Sizing

1. Determine the goals and primary function of the enhanced wet swale.

The goals and primary function of the BMP must take into account any restrictions or site-specific constraints. Also take into consideration any special surface water or watershed requirements.

- Enhanced wet swales must be designed for the target water quality volume because they do not provide runoff reduction volume credits.
- Consider if the BMP can be “oversized” to include the channel protection volume.

2. Size flow diversion structure, if needed.

Determine if the enhanced wet swale will be on-line or off-line. If the enhanced wet swale will be off-line, a flow regulator (or flow splitter diversion structure) should be supplied to divert the WQ_v to the swale. The design storm peak flow is needed for sizing an off-line diversion structure. See section 10.8.2 for more information on bypass structures.

3. Calculate the Target Water Quality Volume

Calculate the water quality volume formula using the following formula:

$$WQ_v = \frac{1.2 \text{ in} \times (R_v) \times A \times 43560 \frac{\text{ft}^2}{\text{acre}}}{12 \frac{\text{in}}{\text{ft}}}$$

Where:

WQ_v = water quality volume (ft³)

R_v = volumetric runoff coefficient. See section 10.4 for volumetric runoff coefficient calculations.

A = onsite drainage area of the post-condition basin (acres)

4. Determine channel geometry and pretreatment volume required.

Size bottom width, depth, length, and slope necessary to treat the water quality volume with less than 18 inches of ponding at the downstream end.

5. Check 2-year and 25-year velocity erosion potential, if the BMP is online.

Check for erosive velocities and modify design as appropriate. Ensure non-erosive velocities for the 25-year event or the 50-year event if the swale is in a sag and armor 1” above this level.

6. Confirm the swale can pass all design requirements with required freeboard.

7. Design the outlet control structure and emergency overflow.

The orifice should be sized to allow the WQ_v to drain down within 48 hours.

Determine the flow rate of the WQ_v discharging from the swale within 48 hours.

$$Q = \frac{WQ_v}{(24 \text{ hours}) \left(60 \frac{\text{min}}{\text{hr}}\right) \left(60 \frac{\text{s}}{\text{min}}\right)}$$

Determine the size of the orifice that allows the WQ_v to drain down within 48 hours.

$$Q = C_d \times A \times (2gh)^{0.5}$$

Where:

Q = Peak flow (ft³/s)

C_d = Orifice coefficient = 0.6

A = Area of orifice (ft²)

g = Gravitational constant (32.2 ft/s²)

h = Depth of water to center of orifice (ft)

The diameter of the orifice shall be determined as follows:

$$A = \frac{\pi d^2}{4}$$

If the BMP is online, an overflow must be provided to bypass and/or convey larger flows to the downstream drainage system or stabilized watercourse. The 100-year storm should pass within the emergency spillway without overtopping the swale in any other location. Non-erosive velocities need to be ensured at the outlet point. The overflow should be sized to safely pass the peak flows anticipated to reach the practice, up to a 100-year storm event.

The overflow weir should be designed to allow the enhanced wet swale to safely pass the 25-year, 24-hour storm event with a minimum 6 inches of freeboard. The following weir equation is used to determine weir length of a broad-crested weir.

$$Q = C_d \times L \times H^{\frac{3}{2}}$$

Where:

Q = Peak flow (ft³/s)

C_d = Weir coefficient = 2.6

L = Length of weir (ft)

H = Depth of water above weir crest (ft)

8. If applicable, complete a water balance analysis to verify the enhanced wet swale will maintain its permanent pool.
9. Prepare a vegetation and landscaping plan

A landscaping plan for an enhanced wet swale should be prepared to indicate how vegetation will be established. See the Vegetation section above and the GDOT Planting Schedule Special Construction Detail for additional guidance.

Enhanced Wet Swale Example Calculation

GIVEN:

- A new roadway project located in Dallas, Georgia.
- The proposed project includes 1,500 feet of roadway (in length).
- Approximately 300 feet is available for enhanced wet swale; good vegetative cover can be established and maintained upgradient of the proposed BMP.
- The drainage area that discharges to the enhanced wet swale includes the following: two 12-foot lanes, a 6-foot paved shoulder, and a 20-foot wide grassed area, draining via sheet flow.
- 18 feet of available width will be present in the typical section for installation of the enhanced wet swale.
- The maximum permanent pool depth is 6 inches.
- The site meets all other site constraints such that an enhanced wet swale is appropriate for use.
- The designer has previously calculated the following hydrologic information:
 - $WQ_v = 4,548 \text{ ft}^3$
 - $Q_{wq} = 1.5 \text{ ft}^3/\text{s}$
 - $Q_{p25} = 10.7 \text{ ft}^3/\text{s}$

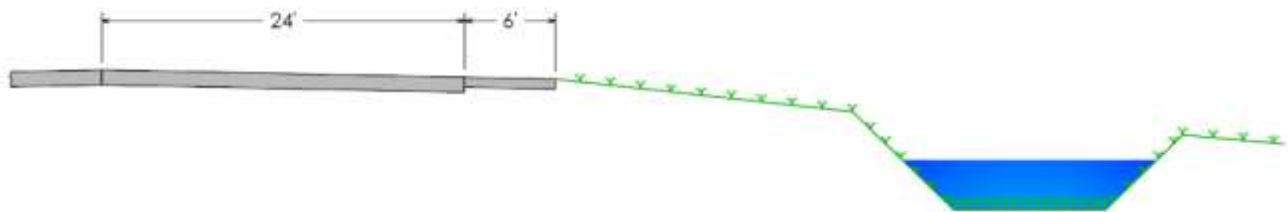

FIND:

- The enhanced wet swale size and configuration that meets the site constraints and provides the required water quality treatment.

SOLUTION:

1. The enhanced wet swale will be sized for the water quality volume.
2. The water quality volume was already calculated to be 4,548 ft³.
3. Based on the existing ground geometry, the enhanced wet swale will utilize a length of 300 feet. Size bottom width, depth, and side slopes necessary to treat the water quality volume with less than 18 inches of ponding at the downstream end.

Assume a base width of 2 feet and side slopes of 3:1. With a permanent pool depth of 0.5 foot (12 inches), the top width of the permanent pool is 8 feet.

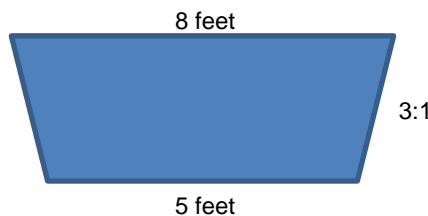

The basic volume formula for a trapezoidal prism is:

$$V = L \times \left[h \times \frac{(a + b)}{2} \right]$$

Where:

- V = Volume of trapezoidal prism
- L = Length of prism
- h = Height of trapezoid
- a = Top length of trapezoid
- b = Bottom length of trapezoid

The top width of the channel, T, is a function of the water quality volume depth.

$$T = a + (2 \times 3 \times d_{wq})$$

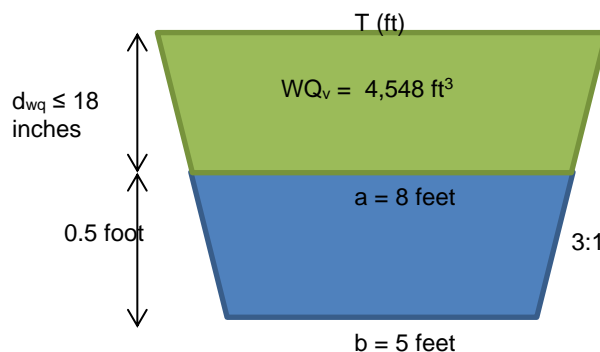

Solve for the water quality volume depth.

$$4,548 = 300 \times \left\{ d_{wq} \times \frac{[8 + (2 \times 3 \times d_{wq})] + 8}{2} \right\}$$

$$d_{wq} = 1.3 \text{ ft (ok because less than 18 inches)} \rightarrow \text{round up to 1.5 ft}$$

Check that the top width is less than the 18 feet available.

$$T = 8 + (2 \times 3 \times 1.5) = 17 \text{ feet}$$

4. Next, check the 25-year velocity erosion potential and freeboard.

- $Q_{p25} = 10.7 \text{ ft}^3/\text{s}$
- $n = 0.1$ (assumed for this example)
- Flow velocity = 1.3 ft/sec **Non-erosive (less than 4 ft/sec) OK**
- Flow depth = 1.4 ft

Add 0.5 feet to the flow depth for freeboard and 0.5 foot for the permanent pool to get overall channel depth equal to 2.4 feet.

Verify that channel design meets all design requirements as outlined in the open channel design policy as outlined in chapter 5.

5. Determine the flow rate of the WQ_v discharging from the swale within 48 hours:

$$Q = \frac{\text{Volume}}{\text{Time}} = \frac{4,548 \text{ ft}^3}{(48 \text{ hours}) \left(60 \frac{\text{min}}{\text{hr}}\right) \left(60 \frac{\text{s}}{\text{min}}\right)} = 0.0265 \text{ ft}^3/\text{s}$$

Next, the following orifice equation is used to determine the size of the orifice:

$$Q = C_d \times A \times (2gh)^{0.5}$$

Where:

Q = Peak flow = 0.0265 ft³/s

C_d = Orifice coefficient = 0.6

A = Area of orifice (ft²)

g = Gravitational constant (32.2 ft/s²)

h = Depth of water to center of orifice (ft) = 1 ft

The area of the orifice is calculated to be 0.0055 ft², or 0.79 in².

The diameter of the orifice shall be determined as follows:

$$A = \frac{\pi d^2}{4}$$

$$d = \sqrt{\frac{4A}{\pi}} = \sqrt{\frac{4(0.79)}{3.14}} = 1.00 \text{ inches}$$

Therefore, the diameter of the orifice is specified to be 1.00 inch.

Additional design steps:

1. Determine the specifics for the forebay (length, width, depth and stone size).
2. Specify the width of the overflow weir and determine the 25-year maximum stage based on the height of flow at the overflow weir.
3. Determine the top and bottom elevations for the outlet control structure.
4. Determine the size of the discharge pipe.
5. Verify that the outlet structure or discharge conveyance channel can safely convey and discharge the 100-year storm event without overtopping the swale in any other location.
6. If applicable, complete a water balance analysis.
7. Prepare a vegetation and landscaping plan.

Maintenance Considerations

Without proper maintenance, BMPs will function at a reduced capacity and may cease to function altogether. A properly designed BMP includes several considerations for maintenance:

- Provide adequate right-of-way.
- Provide access roads and ramps for appropriate equipment to all applicable components (outlet structure, forebay, etc.).
- Provide space to turn around if necessary.
- Check for sufficient area to safely exit and enter the highway, if applicable.
- Provide a valve or other method for dewatering an enhanced wet swale.

Refer to GDOT's *Stormwater System Inspection and Maintenance Manual*, for specific maintenance requirements.

Summary

10.6.4 Infiltration Trench



Advantages	Disadvantages
<ul style="list-style-type: none"> • Considered a LID/GI control • Provides for groundwater recharge • Good for small sites with porous soils 	<ul style="list-style-type: none"> • Potential for groundwater contamination • Only suitable for smaller drainage areas (5 acres or less) • High clogging potential; should not be used on sites with fine-particled soils (clays or silts) in drainage area • Significant setback requirements • Geotechnical testing required

Description: Infiltration trenches are shallow trenches comprised of an underground reservoir of large crushed stone. The runoff volume slowly exfiltrates (exits the device by infiltrating into the soil) through the bottom and sides of the trench into the subsoil, eventually reaching the water table.

Design Considerations:

- Soil infiltration rate of 0.5 in/hr or greater required
- Excavated trench (2 to 10-foot depth) filled with stone media (1.5 to 2.5-inch diameter); pea gravel and sand filter layers
- Trench is wrapped in non-woven plastic filter fabric (top and sides)
- A forebay, or equivalent upstream pretreatment measure, must be provided.
- Observation well(s) to monitor percolation
- Must not be placed under pavement or concrete

Maintenance Considerations:

- Clogging is a significant concern; locate only in stabilized areas
- Ensure observation well is easily and safely accessible

Applicability for Roadway Projects

- Subsurface drainage direction must be away from the subbase of adjacent roadway or impervious paved area
- Linear nature lends itself well to roadway applications

Direct coordination with the Water Resources Group is required if an Infiltration Trench is determined to be feasible. This coordination needs to occur before submittal of the draft Post Construction Stormwater Report.

Stormwater Management Suitability:

- ✓ Runoff Reduction
- ✓ Water Quality
- Channel Protection
- ✗ Overbank Flood Protection
- ✗ Extreme Flood Protection

✓ Suitable for this practice ○ May provide partial benefits ✗ Not suitable

LID/GI Considerations

Infiltration trenches are considered a LID/GI control. They have the ability to recharge groundwater, which helps to restore a site's natural hydrology.

Treatment Capabilities



10.6.4 Infiltration Trench

Description

Infiltration trenches are shallow trenches comprised of an underground reservoir of large crushed stone. The runoff volume slowly exfiltrates (exits the device by infiltrating into the soil) through the bottom and sides of the trench into the subsoil over a 2 to 3-day period, eventually reaching the water table. Infiltration trenches must always be designed with pretreatment measures as they can clog easily. Forebays are often utilized as pretreatment. In addition, some other BMPs such as grass channels and filter strips can be used in series with an infiltration trench to protect it from clogging. For runoff from large storm events, an overflow outlet, such as a berm or level spreader, is needed for stormwater that cannot be fully infiltrated by the trench.

Infiltration trenches act primarily as water quality BMPs; however, when equipped with underground piping, the temporary storage volume of the trench may be increased to a volume that provides peak runoff rate reduction for the channel protection volume, CP_v . Peak rate control of the 10-year and greater storm events is typically beyond the capacity of an infiltration practice.

By infiltrating runoff into the soil, infiltration trenches serve multiple LID/GI functions including treating the water quality volume, helping to preserve the site's natural water balance, and recharging groundwater. These benefits must be weighed against the tendency for infiltration trenches to become clogged. They should only be incorporated into sites where upstream sediment can be controlled or the upstream drainage area is built out or well stabilized.

Careful attention must be given to avoid siting infiltration trenches where there is potential for groundwater contamination. Also, they cannot be utilized in areas having karst (i.e., limestone) topography as there is potential for sink holes to develop. Figure 10.6.4-1 shows typical infiltration trench components and Figure 10.6.4-2 shows the typical layout of an infiltration trench.

Figure 10.6.4-1 - Typical infiltration trench components

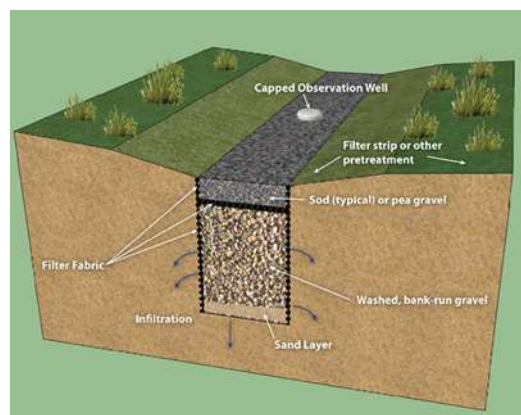
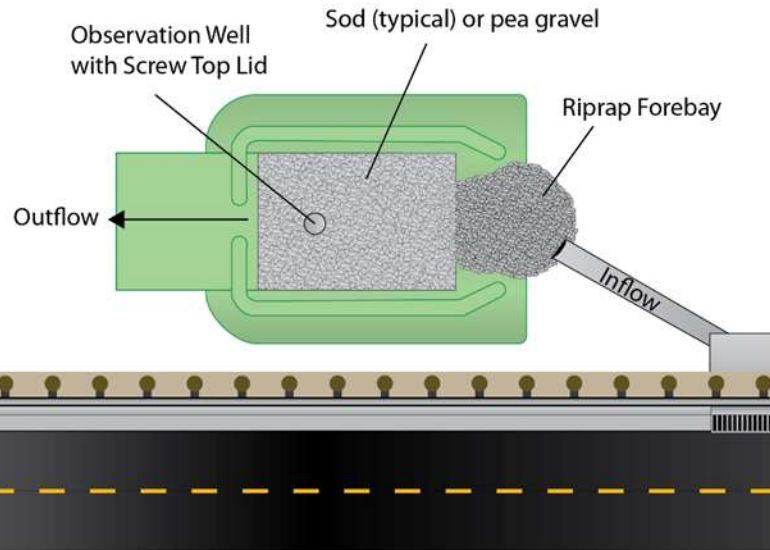
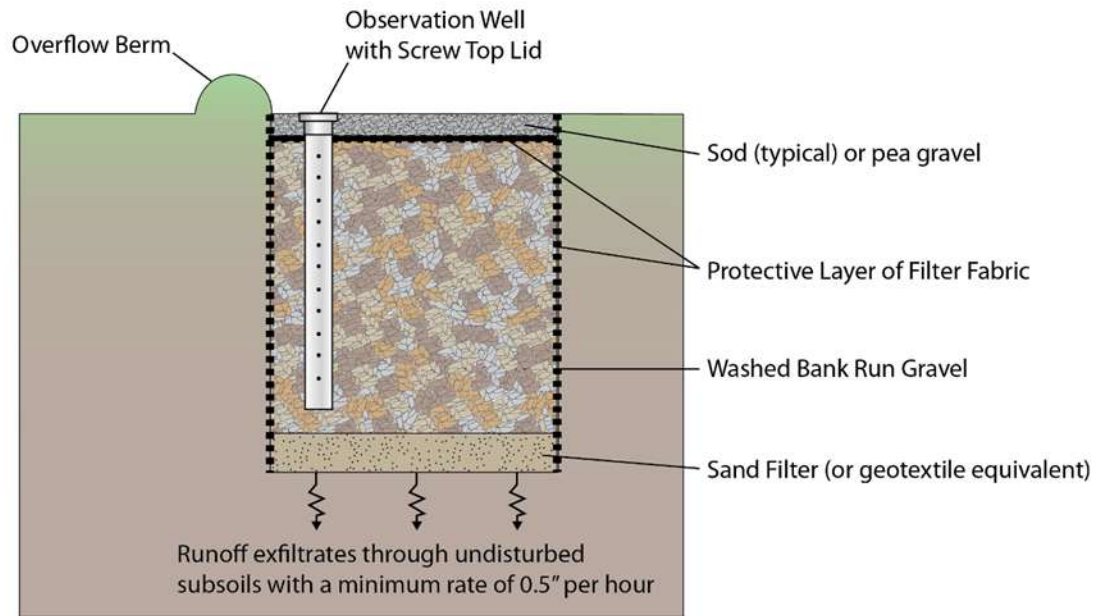

Figure 10.6.4-2 - Typical infiltration trench – plan and profile views



PLAN VIEW



CROSS SECTION

Stormwater Management Suitability

- Runoff Reduction – Infiltration trenches are one of the most effective low impact development (LID) practices that can be used in Georgia to reduce post-construction stormwater runoff and improve stormwater runoff quality. Like other LID practices, they become more effective with

higher infiltration rates of native soils. An infiltration trench can be designed to provide 100% of the runoff reduction volume, if properly maintained.

- Water Quality – The infiltration trench is an excellent stormwater treatment practice due to the variety of pollutant removal mechanisms. Each of the components of the infiltration trench is designed to perform a specific function. The grass filter strip (for sheet flow) or grass channel or forebay (for concentrated flow) pre-treatment component reduces incoming runoff velocity and filters particulates from the runoff. The planting soil or rock in the infiltration practice acts as a filtration system, and clay in the soil provides adsorption sites for hydrocarbons, heavy metals, nutrients and other pollutants. An infiltration trench provides 100% TSS removal if designed, constructed, and maintained correctly.
- Channel Protection – For smaller sites, an infiltration trench may be designed to capture the entire channel protection volume (CP_v). Given that an infiltration trench is typically designed to completely drain over 48-72 hours, the requirement of extended detention for the 1-year, 24-hour storm runoff volume will be met. For larger sites, or where only the WQ_v is diverted to the infiltration trench, another control must be used to provide CP_v extended detention.
- Overbank Flood Protection – Another control will likely be required in conjunction with an infiltration trench to reduce the post-development peak flow of the 25-year storm (Q_{p25}) to pre-development levels (detention).
- Extreme Flood Protection – Infiltration trenches must provide flow diversion and/or be designed to safely pass extreme storm flows.

Pollutant Removal Capabilities

The following average pollutant removal rates may be utilized for design purposes:

- TSS – 100%
- TP – 100%
- TN – 100%
- Fecal coliform – 100%
- Heavy metals – 100%

Application and Site Suitability

Direct coordination with the Water Resources Group is required if an Infiltration Trench is determined to be feasible. This coordination needs to occur before submittal of the draft Post Construction Stormwater Report. Infiltration trenches can be utilized in locations where the subsoil is sufficiently permeable to provide a reasonable infiltration rate and a low water table exists to prevent groundwater contamination. Locating infiltration basins on linear projects in urban settings may not be appropriate as these areas tend to have compacted soils. They are applicable primarily for impervious drainage areas where there are not high levels of fine particulates (clay/silt soils) in the runoff and should only be considered for sites where the sediment load is relatively low. [\(10-17\)](#)

Infiltration trenches generally have a grassed or gravel surface. Infiltration trenches located adjacent to roadways or impervious paved areas must be designed so the subsurface drainage direction flows to the downhill side (away from the subbase of the pavement) or located lower than the impervious

subbase layer. Proper measures should be taken to prevent water from infiltrating into the subbase of impervious pavement. (10-31)

Infiltration trenches can either be used to capture sheet flow from a drainage area or function as an off-line device. Due to the relatively narrow shape, infiltration trenches can be adapted to many different types of sites and can be used in retrofit situations. Unlike some other structural stormwater controls, they can fit into the perimeter or other unused areas of developed sites. Median strip infiltration trenches can be combined with a grass filter strip to direct sheet flow to the trench. Multiple trenches can be incorporated on larger sites or in the upland area of large sites to reduce the amount of runoff needing treatment downstream.

Infiltration trenches are frequently used to infiltrate runoff from adjacent impervious surfaces, such as parking lots. In these cases, a filter strip should be installed between the pavement and the device to trap sediment and litter before it is washed into the infiltration trench. Another approach is to construct infiltration devices at the downgradient edges of areas with permeable pavement. In this case, the permeable pavement is the inlet to the device. As water will also infiltrate through the base of the pavement, the size of the infiltration devices can be reduced significantly. (10-28)

In areas of high traffic or areas where excessive sediment, litter, and other similar materials may be generated, a pretreatment device (such as a forebay) and/or additional BMPs (such as a filter strip or grassed channel) are needed.

In site development applications, roof drains may be connected to infiltration trenches. Roof runoff generally has lower sediment levels and often is ideally suited for discharge through an infiltration trench. A cleanout with sediment sump should be provided between the building and infiltration trench.

Infiltration trenches are not suitable in areas with karst geology without adequate geotechnical testing by qualified individuals and must be installed in accordance with local requirements.

Siting information and constraints include the following:

- **Drainage Area** – The maximum drainage area to an infiltration trench is 5 acres.
- **Space Required** – Required spacing will vary, dependent upon the depth of the facility.
- **Site Slope** – No more than 6% site slope for preconstruction footprint. Infiltration trenches should be designed with slopes that are as close to flat as possible.
- **Minimum Head** – Elevation difference of 1 foot needed for minimum head at a site from the inflow to the outflow.
- **Depth to Water Table** – Four-foot depth recommended between the bottom of the infiltration trench and the elevation of the seasonally high water table, which may be reduced to 2 feet in coastal areas. The separation distance provided should allow the trench to empty completely within a maximum of 72 hours following a runoff producing event.
- **Infiltration Rate** – Infiltration rate greater than 0.5 inches per hour required (typically hydrologic group “A”, some group “B” soils).
 - Soils exhibiting a clay content of greater than 30% and a silt/clay content greater than 40% are unacceptable in order to prevent clogging and failure.

- Clay lenses, bedrock or other restrictive layers below the bottom of the trench will reduce infiltration rates unless excavated.
- **Setbacks** – See the following setback requirements. Confirm there are no local ordinances or criteria.
 - From a property line – 10 feet
 - From a building foundation – 20 feet downslope and at least 100 feet upslope
 - From a private well – 100 feet
 - From a public water supply well – 1,200 feet
 - From a septic system tank/leach field – 100 feet (notify health official if trench is placed in the vicinity of a septic leach field)
 - From surface waters – 100 feet
 - From surface drinking water sources – 400 feet (100 feet for a tributary)
- **Hotspots** – Do not use for hotspot runoff.
- **Trout Stream** – Runoff temperature reduction is provided.
- **Other Considerations** –
 - Infiltration trenches cannot be placed under pavement or concrete.
 - Infiltration trenches are designed for intermittent flow and must be allowed to drain and allow reaeration of the surrounding soil between rainfall events. They must not be used on sites with a continuous flow from groundwater, or other sources. [\(10-17\)](#)
 - Infiltration trenches should not be constructed on or near fill sections due to the possibility of creating an unstable subgrade. Fill areas are vulnerable to slope failure along the interface of the in-situ and fill material. The likelihood of this type of failure is increased when the fill material is frequently saturated, as expected when an infiltration BMP is proposed. [\(10-38\)](#)

General Design Criteria

Sizing and specification criteria include:

- Design to fully dewater the entire RR_v within 72 hours after the rainfall event.
- The bottom slope of the trench must be flat length-wise and width-wise to promote uniform infiltration.
- Generally, the trench's total depth ranges from 2 to 10 feet.
- The width of a trench should be less than 25 feet. Trench widths greater than 8 feet require large excavation equipment rather than smaller trenching equipment. Infiltration trenches that are broader and shallower are less likely to clog as they provide a larger area for infiltration.
- The infiltration trench material should be comprised of GDOT No. 3 aggregate. Aggregate contaminated with soil shall not be used. Use a porosity value, n , (void space/total volume) of 0.40 for GDOT No. 3 aggregate in calculations.

- A 6-inch deep layer of clean, washed sand must be installed at the bottom of the trench. This will promote drainage and prevent compaction of the native soil when the stone is added.
- The infiltration trench should be lined on the sides and top by appropriate non-woven plastic filter fabric capable of preventing surrounding soil piping and able to maintain a greater permeability than the surrounding native soil. The top layer of filter fabric should be located 2 inches from the top of the trench and serves to prevent sediment from passing into the stone aggregate. Since this top layer serves as a sediment barrier, it will need to be replaced more frequently and must be readily separated from the side sections.
- The top surface of the infiltration trench above the filter fabric should typically be covered with sod (typical) or pea gravel. The sod/pea gravel layer will improve sediment filtering and maximize the pollutant removal in the top of the trench. In addition, it can easily be removed and replaced should the device begin to clog.
- Refer to Special Provision 169 for more information.

The required storage volume is equal to the RR_v . For smaller sites, an infiltration trench can be designed with a larger storage volume to include the CP_v . Refer to section 10.4 of this chapter for guidance on calculating these volumes.

Note that it is often the case in roadway systems that length and particularly width are predetermined by constraints such as limited right-of-way and edge of pavement. Depth can often be adjusted to meet sizing requirements unless shallow groundwater or bedrock are present. Note that reduced surface area of the trench increases the likelihood of clogging and tends to yield less stormwater treatment.

Observation Well

An observation well is recommended at an interval of every 50 feet along the entire trench length. Observation wells provide a means by which dewatering times can be observed to check that the trench is emptying within the maximum allowable time of 72 hours. Generally, the observation well is constructed of perforated pipe and should extend to the bottom of the trench.

Pretreatment

Pretreatment facilities must always be used in conjunction with an infiltration trench to prevent clogging and failure. Roadways and parking lots often produce runoff with high levels of sediment, grease, and oil. These pollutants can potentially clog the pore space in the trench, thus rendering its infiltration and pollutant removal performance ineffective. Multiple pretreatment measures are recommended such as forebays, or other BMPs including grass channels and filter when implemented in series.

Where sheet flow enters the trench from an adjacent drainage area, the pretreatment system should consist of a vegetated filter strip with a minimum 25-foot length. A vegetated buffer strip around the entire trench is required if the facility is receiving runoff from all directions. If the infiltration rate for the underlying soils is greater than 2 inches per hour, 50% of the RR_v should be pretreated by another method prior to reaching the infiltration trench.

For off-line configurations, pretreatment should consist of a forebay sized to 25% of the WQ_v . Exit velocities from the pretreatment must be nonerosive for the 25-year design storm. See section 10.5.4 for additional information on off-line configurations.

Vegetation

Refer to GDOT Special Provision 169 – Post-Construction Stormwater BMP Items for guidance on selecting and placing sod.

Emergency Spillway

Because of the small drainage area served by an infiltration trench, an emergency spillway is typically not required; however, a non-erosive overflow channel or storm sewer system must be located at the downstream end of the trench. If an overflow berm surrounding the infiltration trench is incorporated into the design, the emergency spillway can be a depressed portion of the overflow berm, acting as weir, discharging flows in excess of the RR_v to the channel or storm sewer downgradient. Overflow berms are sized to contain the RR_v within the infiltration trench, preventing stormwater from bypassing across or around its surface.

Alternative Design Options

For off-line infiltration trench configurations, the RR_v is diverted to the infiltration trench through the use of a flow bypass structure (see section 10.8.2 of this chapter for guidance on flow bypass structure design). Where stormwater flows are greater than the RR_v , divert the flow to other controls or downstream using a diversion structure or flow splitter.

Provisions for Overflow

Provisions for overflow may be needed for undersized infiltration trenches or for infiltration trenches that treat larger drainage areas. Overflow configurations can include a perforated pipe system with up-turned vertical section, elevated catch basin (similar to a riser), or an emergency spillway channel. The perforated pipe system should be designed similar to an underdrain as presented in section 10.8, Common BMP Components. Pipe material should be polyethylene and consistent with GDOT Specification 573. The pipe and perforations should be sized to convey the desired peak flow (refer to Chapter 7, Table 7.1). See Figure 10.6.4-3 for an example.

Figure 10.6.4-3 - Design example of an infiltration trench overflow system

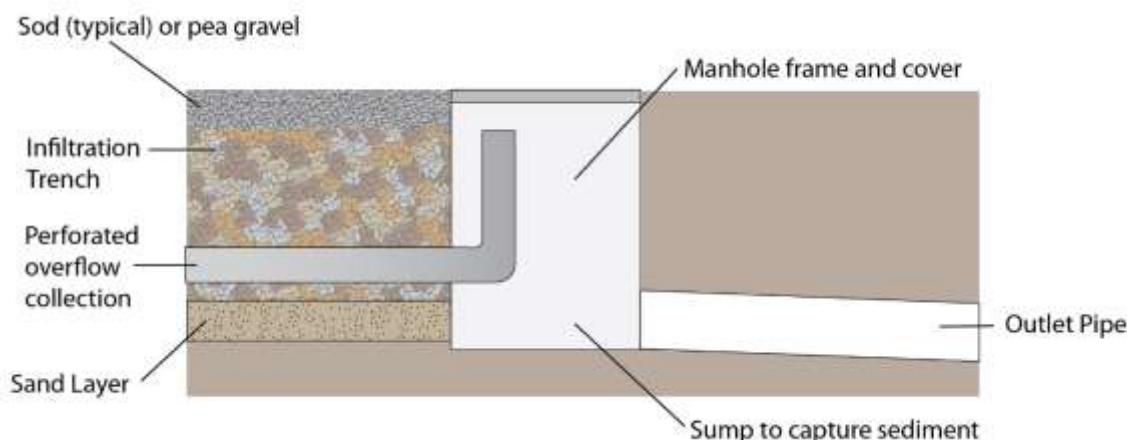

If an elevated catch basin is used, the rim of the catch basin should be set at the desired design storm elevation and will perform the same function as a riser structure would in a detention pond. Large riser structures are typically not required in infiltration trenches because they typically treat smaller drainage areas. Additional information for both risers and emergency spillway channels can be found in section 10.7, Detention Design.

Infiltration Trench Sizing

1. Determine the goals and primary function of the infiltration trench.

The goals and primary function of the BMP must take into account any restrictions or site-specific constraints. Also take into consideration any special surface water or watershed requirements.

- An infiltration trench should be sized to meet the runoff reduction target. *Minimum infiltration rates of the surrounding native soils must be acceptable.*
- Consider if the BMP can be “oversized” to include the channel protection volume.

2. Calculate the Stormwater Runoff Reduction Target Volume.

$$RR_{v(target)} = \frac{1 \text{ in} \times (R_v) \times A \times 43560 \frac{ft^2}{acre}}{12 \frac{in}{ft}}$$

Where:

$RR_{v(target)}$ = runoff reduction target volume (ft³)

A = area draining to this practice (acres)

R_v = volumetric runoff coefficient. See section 10.4 for volumetric runoff coefficient calculations.

3. Determine if the infiltration trench will be on-line or off-line.

If the infiltration trench will be off-line, a flow regulator (or flow splitter diversion structure) should be incorporated into the design to divert the RR_v to the infiltration trench. The design storm peak flow is needed for sizing an off-line diversion structure. See section 10.8.2 for more information on bypass structures.

4. Determine the storage volume of the practice and the pretreatment volume

The actual volume provided in the infiltration trench is calculated using the following formula:

$$VP = PV + VA(N_A)$$

Where:

VP = volume provided (temporary storage)

PV = ponding volume

VA = volume of aggregate

N_A = porosity of aggregate (use 0.4)

Provide pretreatment by using a grass filter strip, as needed (sheet flow), or a grass channel or forebay (concentrated flow). Where filter strips are used, 100% of the runoff should flow across the filter strip. Pretreatment is also necessary to reduce flow velocities and assist in

sediment removal and maintenance. Pretreatment can include a forebay, weir, or check dam. Splash blocks or level spreaders should be considered to dissipate concentrated stormwater runoff at the inlet and prevent scour. For off-line configurations, pretreatment should consist of a forebay sized to 25% of the WQ_v . Otherwise, forebays should be sized to contain 0.1 inches per impervious acre of contributing drainage.

5. Verify the total volume provided by the practice is at least equal to the $RR_{v(target)}$.

When the $VP \geq RR_{v(target)}$ then the runoff reduction requirements are met for this practice. When the $VP < RR_{v(target)}$, then the design must be adjusted or another BMP must be selected and designed for the drainage area.

6. Verify that the infiltration trench will drain in the specified timeframes.

Verify that the entire volume provided by the BMP will drain within 72 hours.

$$t_f = \frac{VP}{(k_{design})A_a}$$

Where:

t_f = drain time (days)

VP = total volume provided by practice (ft^3)

k_{design} = design infiltration rate of underlying soil (ft/day) The design infiltration rate is equal to the observed, in-situ, infiltration rate divided by the factor of safety. Refer to Appendix J for additional guidance.

A_a = bottom surface area of aggregate (ft^2)

7. Design outlet control structure and emergency overflow

An overflow must be provided to bypass and/or convey larger flows to the downstream drainage system or stabilized watercourse. Non-erosive velocities need to be ensured at the outlet point. The overflow should be sized to safely pass the peak flows anticipated to reach the practice, up to a 100-year storm event.

Maintenance Considerations

Without proper maintenance, BMPs will function at a reduced capacity and may cease to function altogether. A properly designed BMP includes the following considerations for maintenance:

- Provide adequate right-of-way.
- Provide access roads and ramps for appropriate equipment to all applicable components (observation well, forebay, etc.).
- Provide space to turn around if necessary.
- Check for sufficient area to safely exit and enter the highway, if applicable.
- Provide an observation well at an interval of every 50 feet along the entire trench length to provide a means by which dewatering times can be observed.

Refer to GDOT's *Stormwater System Inspection and Maintenance Manual*, for specific maintenance requirements.

Infiltration Trench Example Calculation

GIVEN:

- A new roadway project located in Savannah, Georgia.
- The proposed project includes 1,500 feet of roadway (in length) that discharges into an impaired stream.
- Assume that approximately 300 feet is available for an infiltration trench; good vegetative cover can be established and maintained upgradient of the proposed BMP. Runoff exits the roadway as sheet flow via shoulder sections.
- Assume eight feet of available width will be present in the typical section for installation of the infiltration trench.
- Assume the infiltration rate of the existing soil with a factor of safety is 1.5 inches per hour and the site meets all other site constraints for an infiltration trench to be utilized.
- Assume the CP_v , Q_{p25} , and Q_f requirements are not applicable.
- The designer has previously calculated the following hydrologic information:
 - $RR_v = 2,832 \text{ ft}^3$

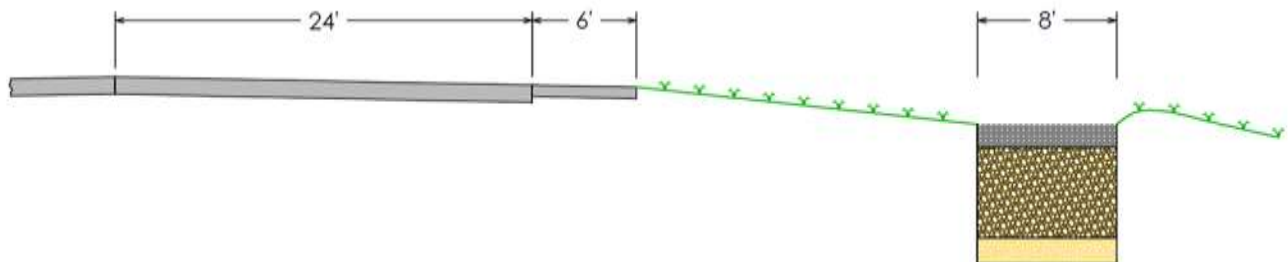

FIND:

- The infiltration trench depth and configuration that meets the site constraints.

SOLUTION:

1. The infiltration trench will be sized solely for runoff reduction. The CP_v , Q_{p25} , and Q_f requirements are not applicable.
2. The runoff reduction volume was already calculated to be $2,832 \text{ ft}^3$.
3. The actual volume provided in the infiltration trench is calculated using the following formula:

$$VP = PV + VA(N_A)$$

Where:

VP = volume provided (temporary storage)

PV = ponding volume

VA = volume of aggregate

NA = porosity of aggregate (use 0.4)

Assume 0.5 ft can pond along the length of the infiltration trench. Use the available surface area to find the minimum depth of the infiltration trench.

$$2,832 \text{ ft}^3 = (0.5 \text{ ft} \times 8 \text{ ft} \times 300 \text{ ft}) + (\text{depth} \times 8 \text{ ft} \times 300 \text{ ft})(0.4)$$

$$\text{depth} = 1.7 \text{ feet}$$

→ round up to 2.0 feet to meet minimum design requirements and for constructibility

Therefore, the infiltration trench will be 8 feet wide by 2 feet deep by 300 feet long.

Runoff exits the roadway via sheet flow over a grassed shoulder. The shoulder is presumed to provide adequate pretreatment to prevent clogging of the infiltration trench and no further action is required.

4. The total volume provided (3,312 ft³) is greater than the target runoff reduction volume (2,832 ft³).
5. Verify that the entire volume provided by the BMP will drain within 72 hours.

$$t_f = \frac{VP}{(k_{design})A_a}$$

Where:

t_f = drain time (days)

VP = total volume provided by practice (8 ft by 300 ft by 3 ft = 7,200 ft³)

k_{design} = design infiltration rate of underlying soil (1.5 in/hr)

A_a = bottom surface area of aggregate (8 ft by 300 ft = 2,400 ft²)

$$t_f = \frac{7,200 \text{ ft}^3}{\left(\frac{1.5 \text{ in}}{\text{hr}}\right) \left(\frac{1 \text{ ft}}{12 \text{ in}}\right) (2,400 \text{ ft}^2)} = 24 \text{ hours}$$

Therefore, the infiltration trench will drain within the specified timeframe.

Summary

10.6.5 Bioslope



Advantages	Disadvantages
<ul style="list-style-type: none"> • LID/GI design practice • Water quality benefits • Applicable in highly constrained areas • Flexible design options: can provide storage and infiltration 	<ul style="list-style-type: none"> • Sheet flow is required • Unsuitable for steep embankments • Does not typically provide detention

Description: A BMP with engineered media and an underdrain installed on slopes or embankments. Sheet flow from paved areas infiltrates into the highly permeable media where it is filtered before exiting through the underdrain. High flows bypass the bioslope in the form of sheet flow running over the bioslope.

Design Considerations:

- Flow path between edge of pavement and bioslope <30 feet (preferred)
- Bioslope length typically equals the length of paved area treated
- Bioslope width is sized to capture the Q_{wg}
- Pretreatment through filter strip preferred

Applicability for Roadway Projects

- Lateral slope <3:1 (< 4:1 preferred)
- Longitudinal slope $\leq 5\%$
- Sheet flow required
- Linear configuration and minimal required space lend itself well to roadway environment

Maintenance Considerations:

- Provide markers or GPS location as bioslopes are difficult to distinguish from typical roadside embankments
- Provide underdrain cleanouts for inspection and to avert clogging

Stormwater Management Suitability:

- Runoff Reduction
- Water Quality
- Channel Protection
- Overbank Flood Protection
- Extreme Flood Protection

✓ Suitable for this practice ◯ May provide partial benefits ✗ Not suitable

LID/GI Considerations

Bioslopes exhibit many LID/GI characteristics. Bioslopes treat runoff near the source using natural processes and often promote infiltration.

Treatment Capabilities

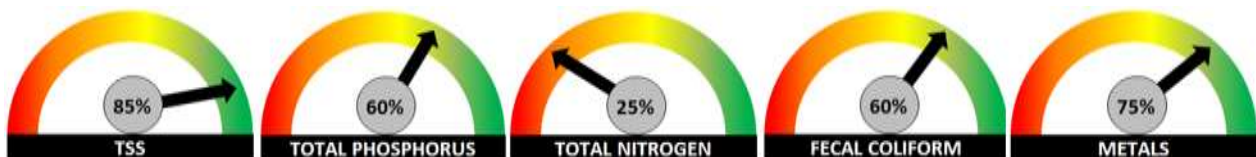

10.6.5 Bioslope

Description

Bioslopes are filtration BMPs that are typically installed in roadway embankments. A special media allows sheet flow from the roadway to rapidly infiltrate and filter through the bioslope where it is then collected and conveyed by an underdrain parallel to the roadway. Runoff in excess of the design flow rate bypasses the bioslope in the form of sheet flow that does not infiltrate. A filter strip is recommended, if space allows, and is typically placed directly upstream of the bioslope for pretreatment where it captures sediment and debris and prevents premature clogging of the bioslope. Bioslopes combine the benefits of filter strips and dry enhanced swales, providing cost effective treatment in areas where it is challenging to implement other BMPs. Figure 10.6.5-1 illustrates the typical bioslope components and treatment processes.

Figure 10.6.5-1 - Typical bioslope components and treatment processes

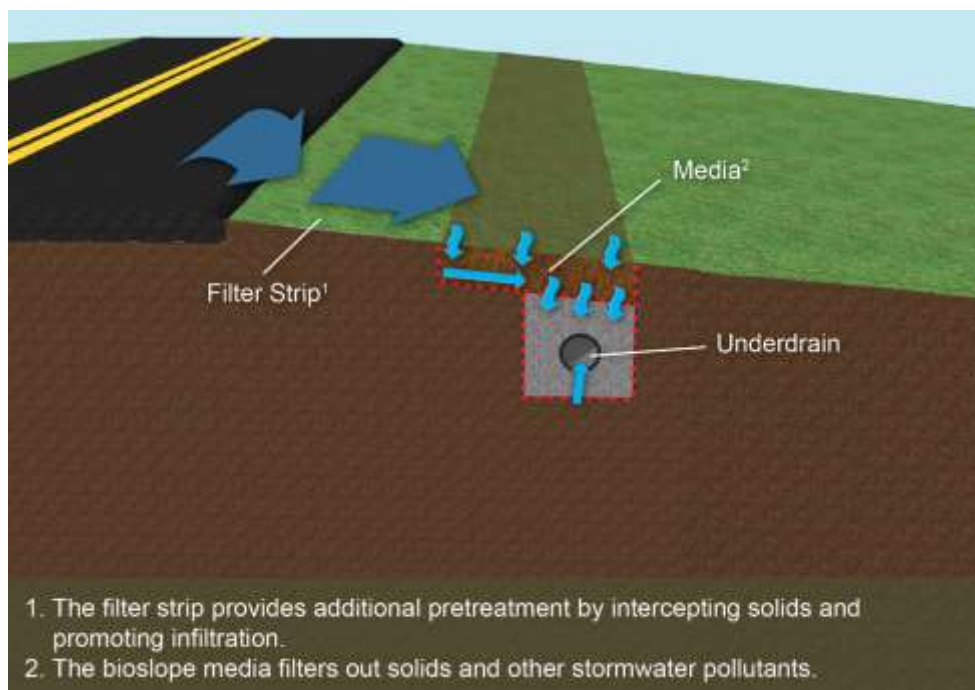

Stormwater Management Suitability

- **Runoff Reduction** – Bioslopes can provide 50% of the runoff reduction volume for type A and B hydrologic soils or 25% of the runoff reduction volume for type C and D hydrologic soils.
- **Water Quality** – Bioslopes rely primarily on filtration through an engineered media to provide removal of stormwater contaminants. The pretreatment component, commonly a vegetated filter strip, is most effective at sediment/debris removal, whereas the engineered media is capable of removing other pollutants. A bioslope provides 85% TSS removal if designed, constructed, and maintained correctly.
- **Channel Protection** – Generally, only the WQ_v is treated by a bioslope, so another BMP must be used to provide CP_v extended detention. However, for some smaller sites, a bioslope could provide some benefit towards detaining a portion of the full CP_v .

- Overbank Flood Protection – Bioslopes do not provide stormwater quantity control and should be designed to safely pass overbank flood flows. Another BMP must be used in conjunction with a bioslope to reduce the post-development peak flow of the 25- year storm (Q_{p25}) to pre-development levels (detention).
- Extreme Flood Protection – Bioslopes do not provide stormwater quantity control and should be designed to safely pass overbank flood flows. Another BMP must be used in conjunction with a bioslope to reduce the post-development peak flow of the 100- year storm (Q_i) to pre-development levels (detention).

Pollutant Removal Capabilities

The following average pollutant removal rates may be utilized for design purposes:

- TSS – 85%
- TP – 60%
- TN – 25%
- Fecal coliform – 60%
- Heavy metals – 75%

Pollutant removals values for TSS, TP, and heavy metals are based on research performed by the Washington State Department of Transportation. [\(10-39\)](#) Pollutant removal values for TN and fecal coliform are based on media filter removal rates published in a synthesis performed by the National Cooperative Highway Research Program. [\(10-29\)](#)

Application and Site Suitability

Bioslopes are applicable for roadway embankments where runoff exits the pavement as sheet flow. Bioslopes may be most practical in areas where limited right-of-way or other constraints preclude the use of enhanced swales, infiltration trenches, or similar BMPs that would otherwise collect and convey stormwater at the toe of the slope. Under ordinary circumstances, GDOT is not required to implement post-construction BMPs where runoff exits the right-of-way as sheet flow and does not cause instability, erosion, or flooding. Therefore, it may not be feasible to construct bioslopes in many of the areas where they would otherwise be utilized. However, if the project is located within a watershed that has an impaired waters, trout stream protection, or similar permit requirement, bioslopes can provide effective treatment in challenging areas. Figure 10.6.5-2 illustrates a typical bioslope configuration.

Figure 10.6.5-2 - Typical bioslope configuration (adapted from NCHRP, 2006) [\(10-27\)](#)

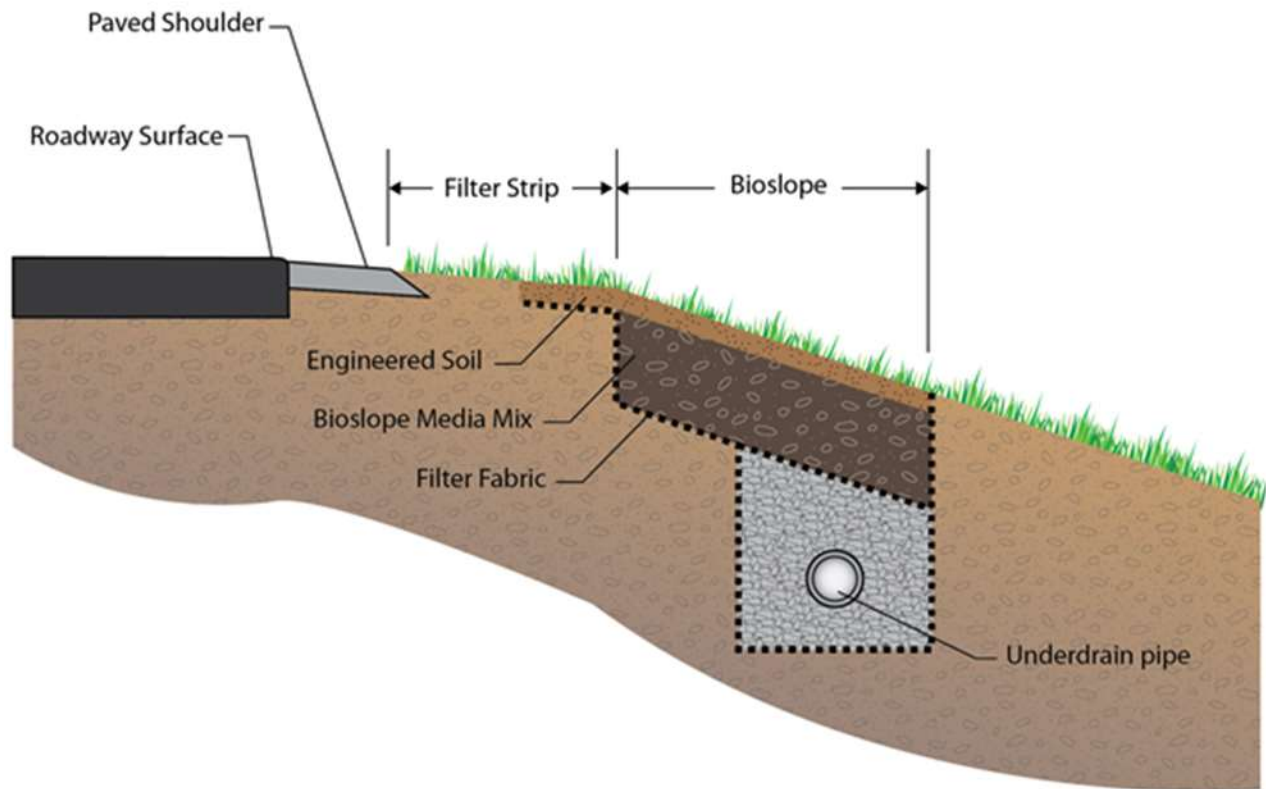

Sizing and specification criteria include:

- Preferably, the area between the edge of the pavement and the bioslope should be less than 30 feet to prevent flow from reconcentrating and eroding the roadway embankment or bioslope. [\(10-26\)](#)
- **Slopes** – Embankment slopes should be 3:1 or flatter. [\(10-26\)](#) Guardrail shall not be placed for the purpose of installing a bioslope. However, if guardrail is needed regardless of the bioslope, the bioslope may be placed behind guardrail given that the bioslope is no steeper than 3:1. Slopes greater than 4:1 may require additional stabilization such as TRM or plastic turf reinforcement grid products. Longitudinal slopes should be 5% or less. [\(10-39\)](#)
- **Depth to Water Table** – Two feet of separation is required between the bottom of the bioslope and the seasonally high water table.

Data for Design

The initial data needed for bioslope design may include the following:

- Existing and proposed site, topographic and location maps, and field reviews
- Field-measured topography or digital terrain model (DTM)
- Aerial/site photographs
- Drainage basin characteristics

- Preliminary plans including plan view, roadway and drainage profiles, cross sections, utility plans, and soil report
- Environmental constraints
- Design data of nearby hydraulic structures
- Additional survey information
- Groundwater elevations

Pretreatment

Where space allows, filter strips should be installed upstream of bioslopes to prevent the bioslope from clogging. Guidance for filter strips is provided in section 10.6.1 of this manual and should be followed when possible; however, if adequate space is not available, the minimum filter strip width (lateral) is not required when applied upstream of a bioslope.

Bioslope Media

The media should have a minimum depth of 12 inches. Bioslope media is a mixture of crushed rock, dolomite, gypsum, and perlite. Crushed rock provides structure to the media; dolomite and gypsum promote the removal of heavy metals from runoff; and perlite enhances moisture retention. The media mixture is described in detail in Supplemental Specification on Post Construction Stormwater BMP Items. The media mixture is designed for an initial infiltration capacity of 50 inches per hour, with a long-term infiltration capacity of 28 inches per hour. The bioslope is sized using an infiltration rate of 10 inches per hour as a factor of safety. (10-39) Provide a minimum of 4-6 feet between the paved shoulder and the bioslope media.

Underdrain

An underdrain collects and conveys the stormwater that has filtered through the media. For bioslope applications, the underdrain trench/aggregate area cross-section should be at least 2-feet wide. (10-39) The underdrain pipe should be sized to convey the design flow (typically Q_{wq}) but should be no less than 8 inches in diameter. Filter fabric should completely encase the underdrain coarse aggregate (top, bottom, and sides). Refer to section 10.8.3 of this manual for additional information regarding underdrain design.

Underdrains implemented in bioslopes may be significantly longer than those in other BMPs. For this reason, cleanouts or observation wells should be provided every 100 feet and should connect to the underdrain with a tee fitting such that the water level may be observed, and the underdrain may be flushed.

Bioslope Sizing

1. Determine the goals and primary function of the bioslope.

The goals and primary function of the BMP must take into account any restrictions or site-specific constraints. Also take into consideration any special surface water or watershed requirements.

- A bioslope must be designed for the water quality volume. The bioslope, however, can provide some runoff reduction benefit and reduce the required detention volume downstream. To calculate the RR_v credited for the practice (sized for WQ_v), Steps 2 –

4 have to be met, then proceed to Step 5. Otherwise the design process ends with Step 4.

- Consider if the BMP can be “oversized” to include the channel protection volume or meet other detention targets.

2. Calculate the Target Water Quality Volume.

Calculate the water quality volume formula using the following formula:

$$WQ_v = \frac{1.2 \text{ in} \times (R_v) \times A \times 43560 \frac{\text{ft}^2}{\text{acre}}}{12 \frac{\text{in}}{\text{ft}}}$$

Where:

WQ_v = water quality volume (ft³)

R_v = volumetric runoff coefficient. See section 10.4 for volumetric runoff coefficient calculations.

A = onsite drainage area of the post-condition basin (acres)

Note that if the BMP is being sized for CP_v , the required storage volume for CP_v calculated per section 10.4.2 will replace the WQ_v in the formula above.

3. Calculate the Target Water Quality Volume Peak Flow.

Calculate the water quality volume peak flow using the guidance in section 10.4.1.2.1.

4. Determine the length and width of the bioslope and the pretreatment volume required.

The length of the bioslope is typically defined by site constraints and the length of the pavement area desired for treatment. Typically, the length of the bioslope should equal the length of pavement being treated. The width is typically sized such that the rate at which runoff infiltrates into the bioslope is at least as great as the Q_{wq} . Equation 10.6.5-1 should be used to calculate bioslope width. A minimum width of 2 feet is generally used for constructability and to facilitate the overall success and long-term operation of the BMP.

$$W = \frac{C Q_{wq} SF}{kL}$$

(10.6.5- 1)

Where:

W = bioslope width (perpendicular to roadway) (feet)

C = conversion factor = 43,200 [(in/hr)/(ft/s)]

Q_{wq} = water quality volume peak flow (ft³/s)

SF = safety factor equal to 1 (unitless, typical throughout Georgia)

k = infiltration, use long-term infiltration rate of 10 (inches/hour)

L = bioslope length (parallel to roadway) (feet)

5. Calculate the runoff reduction volume conveyed to the practice.

$$RR_v = \frac{1 \text{ in} \times (R_v) \times A \times 43560 \frac{\text{ft}^2}{\text{acre}}}{12 \frac{\text{in}}{\text{ft}}}$$

Where:

RR_v = runoff reduction volume (ft³)

A = area draining to this practice (acres)

R_v = volumetric runoff coefficient. See section 10.4 for volumetric runoff coefficient calculations.

6. Calculate the runoff reduction volume credited.

Using Table 10.5-1 - GDOT BMPs and Associated Pollutant Removals, lookup the appropriate runoff reduction percentage (or credit) provided by the practice:

$$RR_v(\text{credited}) = RR_v(RR\%)$$

Where:

$RR_v(\text{credited})$ = runoff reduction volume provided by this practice (ft³)

RR_v = runoff reduction volume conveyed to this practice (ft³)

RR% = runoff reduction percentage, or credit, assigned to the specific practice

Maintenance Considerations

Without proper maintenance, BMPs will function at a reduced capacity and may cease to function altogether. A properly designed BMP includes several considerations for maintenance:

- Provide adequate right-of-way.
- Provide access roads and ramps for appropriate equipment to all applicable components (outlet structure, forebay, etc.).
- Provide space to turn around if necessary.
- Check for sufficient area to safely exit and enter the highway, if applicable.

Refer to GDOT's *Stormwater System Inspection and Maintenance Manual*, for specific maintenance requirements.

Bioslope Example Calculation

GIVEN:

- A new roadway project located in Savannah, Georgia.
- The proposed project includes 200 feet of roadway (in length).
- Heavy sediment loading is not expected.
- The drainage area that discharges to the bioslope includes the following: two 12-foot lanes and a 6-foot paved shoulder draining via sheet flow.
- There is 25 feet available for both a filter strip and the width of the bioslope along the length of the roadway.
- Assume that no stormwater is collected as “off-site” or “bypass” runoff.
- Assume that the existing ground and available right-of-way is sufficient for a bioslope with a longitudinal slope less than 5% and a length of 200 feet (entire length of roadway).
- The designer has previously calculated the following hydrologic information:
 - $WQ_v = 606 \text{ ft}^3$
 - $Q_{wq} = 0.16 \text{ ft}^3/\text{s}$

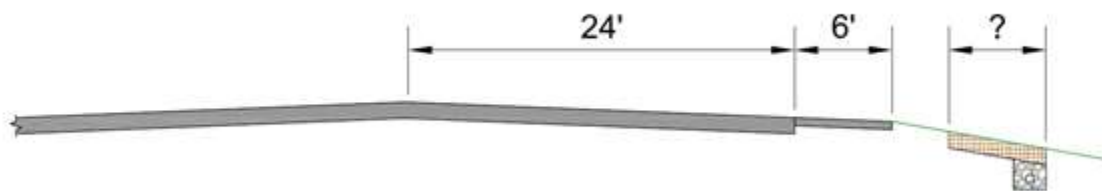

FIND:

- Determine the required width of the bioslope to treat runoff from the proposed roadway.

SOLUTION:

1. The bioslope must be designed for the water quality volume.
2. The water quality volume was already calculated to be 606 ft^3 .
3. The water quality volume peak flow was already calculated to be $0.16 \text{ ft}^3/\text{s}$.
4. Calculate the minimum width of the bioslope using the following formula.

$$W = \frac{CQ_{wq}SF}{kL}$$

Where:

W = bioslope width perpendicular to roadway (feet)

C = conversion factor = $(43,200 \text{ (in/hr)})/(\text{ft/s})$

Q_{wq} = water quality volume peak flow ($0.16 \text{ ft}^3/\text{s}$)

SF = safety factor (equal to 1 unless heavy sediment load is expected)

k = infiltration rate (10 inches/hour)

L = bioslope length parallel to roadway (200 feet)

$$W = \frac{(43,200)(0.16)(1)}{(10)(200)} = 3.5 \text{ ft}$$

Verify that the bioslope meets all design requirements as outlined in this section.

Additional design considerations:

- Complete filter strip design.
- Calculate the runoff reduction credited

Summary

10.6.6 Sand Filter



Advantages	Disadvantages
<ul style="list-style-type: none"> • LID/GI design practice • Effective TSS, nutrient, and fecal coliform removal • Low land requirement • No soil restriction • Appropriate for small areas with high impervious cover 	<ul style="list-style-type: none"> • High capital cost • High maintenance burden • Limited to drainage areas of 10 acres for surface sand filter and 2 acres for perimeter sand filter

Description: Multi-chamber structures designed to treat stormwater runoff through filtration, using a sediment forebay, a sand bed as the primary filter media, and an underdrain collection system.

Design Considerations:

- Drainage area less than 10 acres for surface sand filter and less than 2 acres for perimeter sand filter
- Detain and treat the WQ_v
- Pretreatment through sediment forebay or chamber
- Maximum drain time of 40 hours for WQ_v
- Minimum elevation head of 5 feet for surface sand filter and 2-3 feet for perimeter sand filter
- Must design outlets for CP_v , Q_{p25} , and Q_f
- Provide minimum 2 feet of separation between bottom of sand filter and seasonal high water table

Applicability for Roadway Projects:

- Well suited for small drainage areas with a high percentage of impervious area
- Low land requirement
- Flexibility in basin shape

Stormwater Management Suitability:

- Runoff Reduction
- Water Quality
- Channel Protection
- Overbank Flood Protection
- Extreme Flood Protection

Suitable for this practice
 May provide partial benefits
 Not suitable

Maintenance Considerations:

- Provide adequate access to the BMP and appropriate components.

LID/GI Considerations

Low land requirement and may be incorporated to complement the natural landscape.

Treatment Capabilities

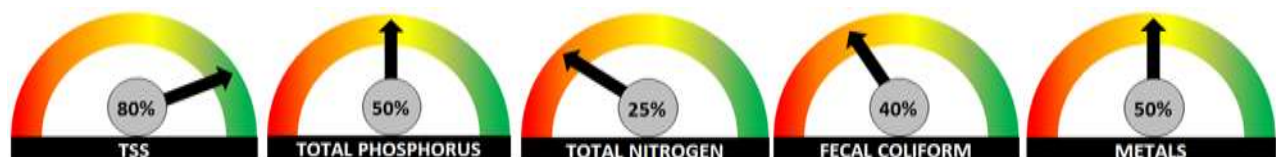

10.6.6 Sand Filter

Description

Sand filters are multi-chamber structures designed to treat stormwater runoff through filtration, using a sediment forebay, a sand bed as the primary filter media, and an underdrain collection system. Sand filters are typically constructed offline for stormwater quality. A sand filter captures and temporarily stores the WQ_v , so that it may be filtered through a bed of sand. Filtered runoff may be returned to the conveyance system or allowed to fully or partially exfiltrate into the soil.

A sand filter is typically composed of two chambers: a sediment forebay or sediment chamber, and a filtration chamber. The sediment forebay serves to remove floatables and heavy sediments while the filtration chamber removes additional pollutants by filtration through the sand bed.

There are two primary sand filter system designs, shown in Figure 10.6.6-1:

- **Surface Sand Filter** – A ground-level open air structure typically located off-line. It can be designed as an excavated basin with earthen embankments or as a concrete block structure.
- **Perimeter Sand Filter** – An enclosed filter system consisting of a sedimentation chamber and a sand bed filter, typically constructed in a below grade vault along the edge of an impervious area. The perimeter sand filter is a flexible, easily accessible BMP that provides good phosphorus removal and additional high oil and grease trapping ability. This type of sand filter may be best suited for site development applications and is further discussed in the GSMM. [\(10-17\)](#)

Figure 10.6.6-1 - Sand filter examples [\(10-17\)](#)

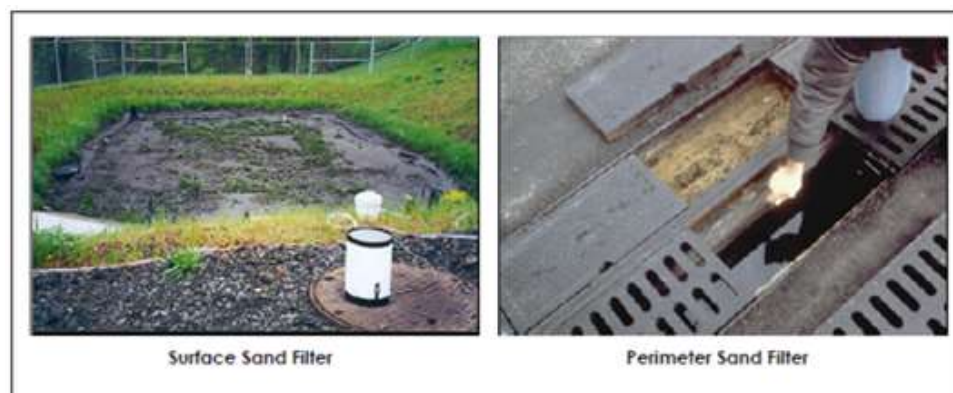

In sand filter systems, stormwater pollutants are removed through a combination of gravitational settling, filtration, and adsorption. This process effectively removes suspended solids and particulates, biochemical oxygen demand (BOD), fecal coliform bacteria, and other pollutants. Surface sand filters with a grass cover have additional opportunities for bacterial decomposition as well as vegetation uptake of pollutants, particularly nutrients.

While sand filters are well suited for small drainage areas with a high percentage of impervious area and have a low land requirement, which would make the sand filter well suited to a roadway environment, capital costs and maintenance burden are high.

Stormwater Management Suitability

- Runoff Reduction – Another BMP should be used in a treatment train with sand filters to provide runoff reduction as they are not designed to provide RR_v as a stand-alone BMP.
- Water Quality – In sand filter systems, stormwater pollutants are removed through a combination of gravitational settling, filtration and adsorption. The filtration process effectively removes suspended solids and particulates, biochemical oxygen demand (BOD), fecal coliform bacteria, and other pollutants. Surface sand filters with a grass cover have additional opportunities for bacterial decomposition as well as vegetation uptake of pollutants, particularly nutrients. A sand filter provides 80% TSS removal if designed, constructed, and maintained correctly.
- Channel Protection – For smaller sites, a sand filter may be designed to capture the entire channel protection volume (CP_v) in either an off- or on-line configuration. Given that a sand filter system is typically designed to completely drain over 40 hours, the time requirement of extended detention of the 1-year, 24-hour storm runoff volume will be met. For larger sites or where only the WQ_v is diverted to the sand filter facility, another structural control must be used to provide CP_v extended detention.
- Overbank Flood Protection – Another BMP must be used in conjunction with a sand filter system to reduce the post development peak flow of the 25-year, 24- hour storm (Q_{p25}) to pre-development levels (detention).
- Extreme Flood Protection – Sand filter facilities must provide flow diversion and/or be designed to safely pass extreme storm flows and protect the filter bed and facility.

Pollutant Removal Capabilities

The following average pollutant removal rates may be utilized for design purposes: [\(10-17\)](#)

- TSS – 80%
- TP – 50%
- TN – 25%
- Fecal Coliform – 40%
- Heavy Metals – 50%

Figure 10.6.6-2 illustrates the treatment processes and target infiltration depths associated with different pollutants for filtration basins. [\(10-21\)](#)

Figure 10.6.6-2 - Sand filter treatment process and target depths

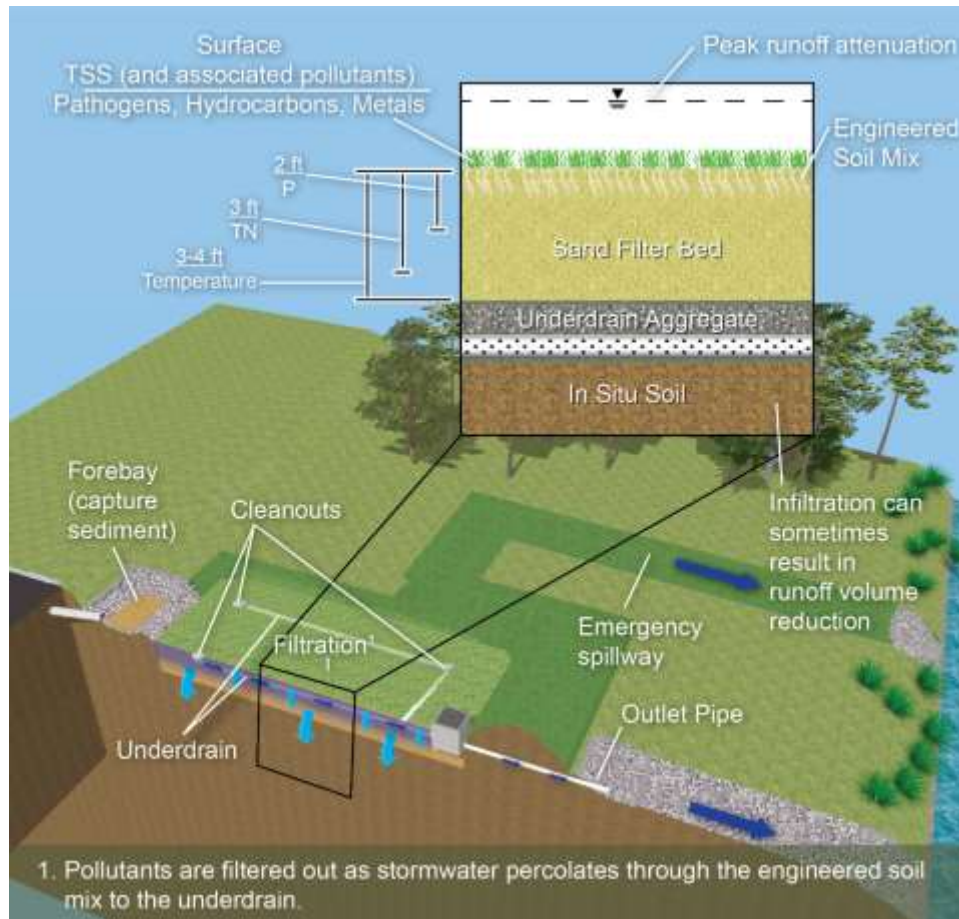

Application and Site Suitability

Sand filters are a high-cost option appropriate for various transportation applications, including roadways, highways, and non-road areas with a high percentage of impervious cover when pollutant reduction is the primary objective of stormwater treatment. The low land requirement of design and flexibility of the basin shape allows for a sand filter to be utilized in areas where available space or right-of-way may be limited. Sand filters may be incorporated into existing topography and can be shaped in various geometric patterns.

When considering locations for a sand filter, the following constraints should be considered:

- **Drainage Area** – Surface sand filters are best suited for small drainage areas, maximum 10 acres
- **Drainage Area Characteristics** – Not well suited for locations with high sediment load. Sand filters should be avoided in areas with less than 50% impervious cover or sites with silt/clay soils to avoid rapid clogging and potential failure of the system.
- **Depth to Water Table** – Minimum 2 feet of clearance between the bottom of a surface sand filter and the seasonal high water table
- **Soils** – No soil restrictions, but Group “A” soils are generally required for exfiltration.

- **Site Slope** – To promote filtration along and across the entire sand filter surface, maximum 6% slope across the filter location.
- **Minimum Head** – Minimum 5 feet of elevation head required between the inflow and outflow points.
- **Trout Stream** – Runoff temperature reduction may be provided with a sand filter. If discharging to a trout stream where temperature is a concern, evaluate for stream warming.
- **Aquifer Protection** - No exfiltration in areas subject to aquifer protection. Impermeable liner should be used
- **Other Considerations** –
 - Sand filters should not be located in wetlands or other environmentally sensitive areas such as live streams (only under special circumstances are post-construction BMPs allowed within environmentally sensitive areas, with prior consent from appropriate regulatory agencies)
 - Sand filters should be placed at an appropriate offset (generally defined by the state) from any surface water (i.e., streams, ponds, lakes, or wetlands)
 - Sand filters are designed to completely drain the water quality volume within 40 hours and reaerate between rainfall events. Therefore, sites with continuous interflow from groundwater, sump pumps, or other sources should not be considered.

Data for Design

The initial data needed for sand filter design may include the following:

- Existing and proposed site, topographic and location maps, and field reviews
- Field measured topography or digital terrain model (DTM)
- Drainage basin characteristics
- Preliminary plans including plan view, roadway and drainage profiles, cross sections, utility plans, and soil report
- Environmental constraints
- Location of nearby surface waters and the depth to groundwater
- Design data of nearby hydraulic structures
- Additional survey information

General Design

The surface sand filter is located at ground level and consists of a perforated pipe and gravel underdrain system in addition to the sediment forebay and filtration chamber. A schematic of a surface sand filter is shown in Figure 10.6.6-3.

Stormwater will first enter the sand filter sedimentation chamber, which allows for the settling of debris and larger sediment particles. The stormwater then flows from the sediment forebay/chamber over a riprap dam to the filtration chamber, which contains the sand media filter. The hydraulic loading of the

filter bed should be evenly distributed in a non-erosive manner. A perforated pipe and gravel underdrain system then collects the stormwater filtered through the sand bed and discharges stormwater from the filter system. Two typical sand filter sections are shown in Figure 10.6.6-4.

Figure 10.6.6-3 - Surface sand filter

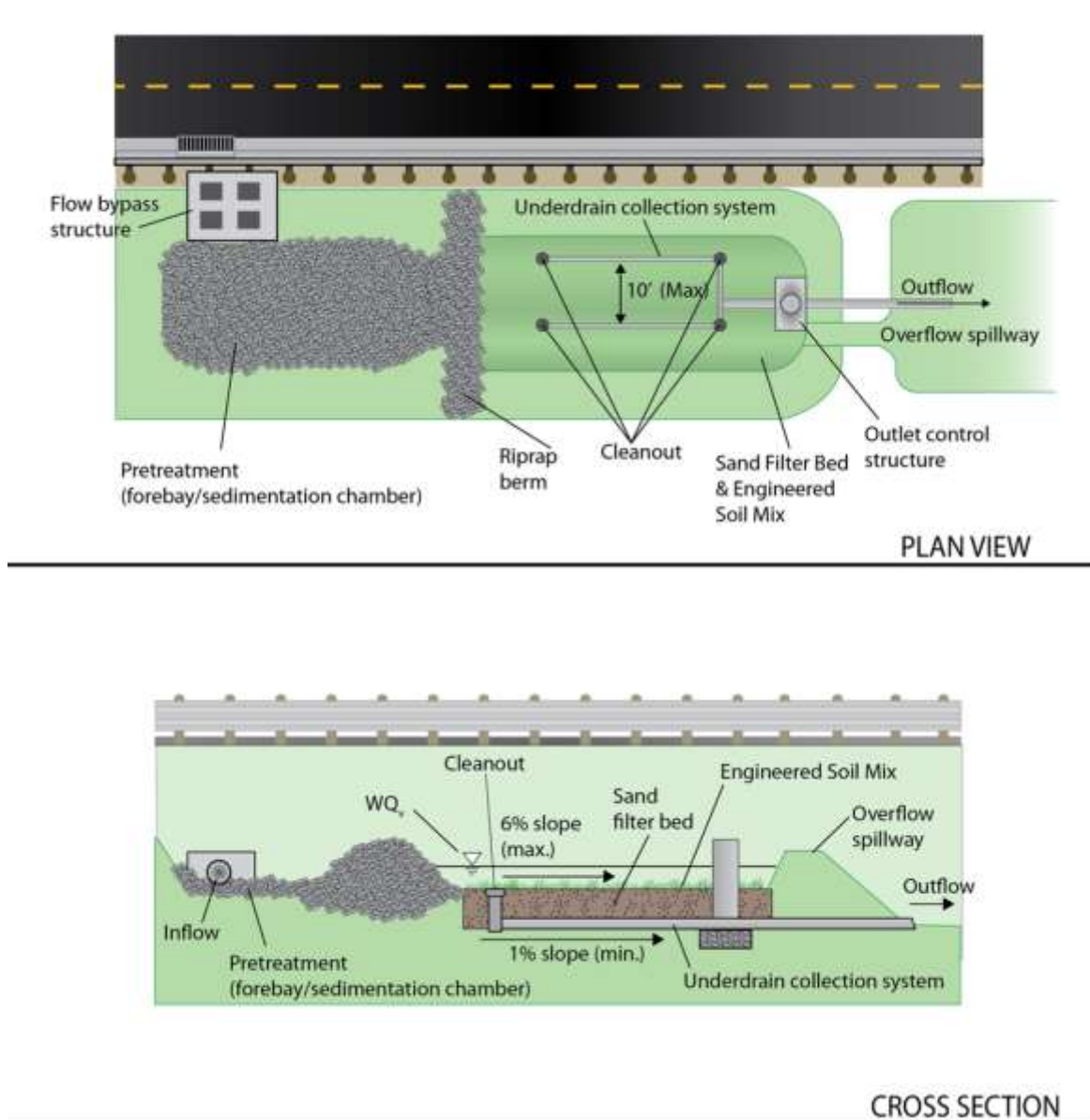
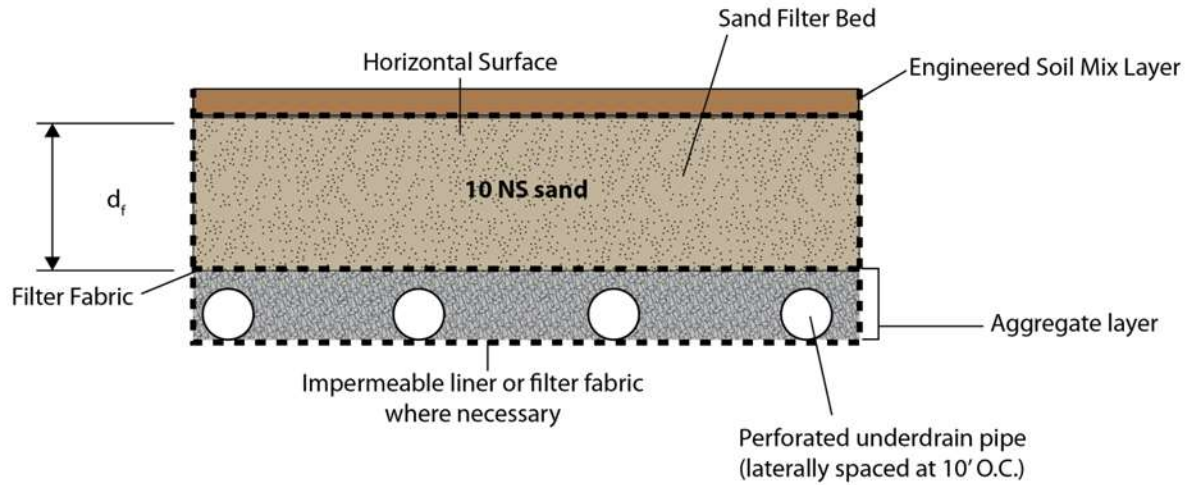
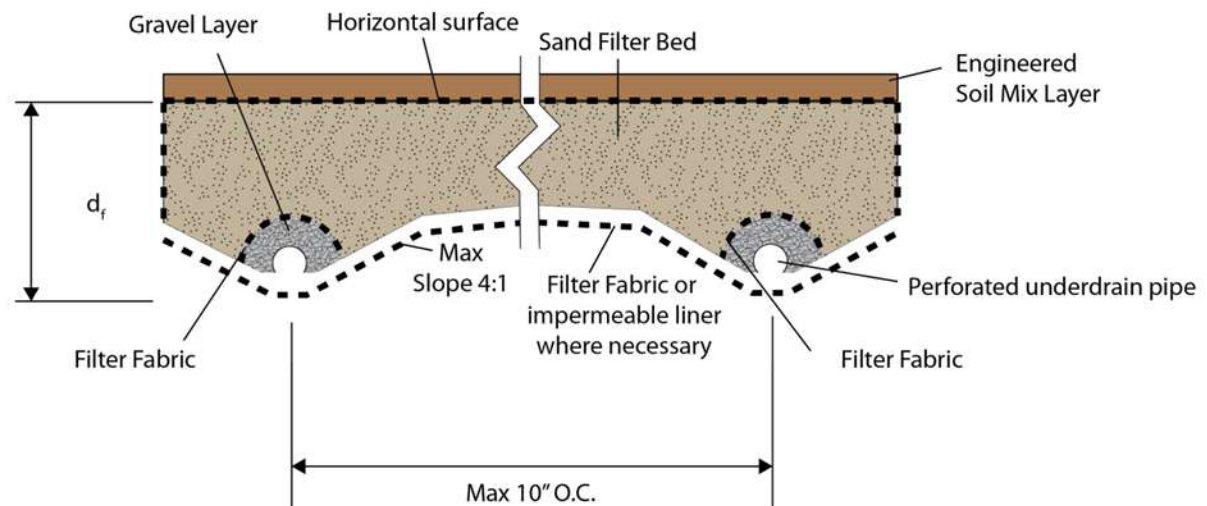

Figure 10.6.6-4 - Typical sand filter sections



OPTION 1



OPTION 2

The following criteria should be observed in the design of a surface sand filter:

- Sedimentation chamber shall be sized to hold a minimum volume based on 25% of the WQ_v with a minimum length to width ratio of 2:1. The Camp-Hazen equation can be used to calculate the required surface area for the sedimentation chamber:

$$A_s = -\frac{Q_o}{w} \times \ln(1 - E)$$

(10.6.6-1)

Where:

 A_s = Sedimentation basin surface area (ft²) Q_o = Rate of WQ_v outflow over 24 hours (ft³/s) w = Particle settling velocity (ft³/s)= 0.0033 ft/s for imperviousness \geq 75%= 0.0004 ft/s for imperviousness $<$ 75% E = Trap efficiency (may use 90% trap efficiency (0.9))

- The filtration chamber can be sized using Equation 10.6.6-2 based on Darcy's Law:

$$A_f = \frac{WQ_v \times d_f}{k(h_f + d_f)t_f}$$

(10.6.6-2)

Where:

 A_f = Surface area of filter bed (ft²) WQ_v = Water quality volume (ft³) d_f = Filter bed depth, sand only (ft) k = Coefficient of permeability of filter media (ft/day) (3.5 ft/day for sand) h_f = Average height of water above filter bed (ft)(1/2 h_{max} , which varies based on design but h_{max} typically \leq 6 feet) t_f = Design filter bed drain time (days)

(1.67 days or 40 hours recommended maximum)

System Storage Volume

The entire treatment system (including the sedimentation chamber) must temporarily hold at least 75% of the WQ_v prior to filtration. Figure 10.6.6-5 illustrates the distribution of the volume to be treated ($0.75 * WQ_v$) among the various components of the surface sand filter.

$$V_{min} = 0.75 \times WQ_v = V_s + V_f + V_{temp}$$

(10.6.6-3)

Where:

 WQ_v = Water quality volume (ft³) V_f = Filter bed voids volume (ft³)= $A_f d_f n$ A_f = Surface area of the filter media (ft²) d_f = Depth of filter media (ft) n = Porosity (0.4 for most applications) V_{temp} = Temporary volume stored above the filter bed (ft³)= $2 \times h_f \times A_f$ h_f = Average water depth above filter media (ft) V_s = Sediment chamber volume (ft³)= $V_{min} - V_f - V_{temp}$

Figure 10.6.6-5 - Volume distribution schematic of a surface sand filter

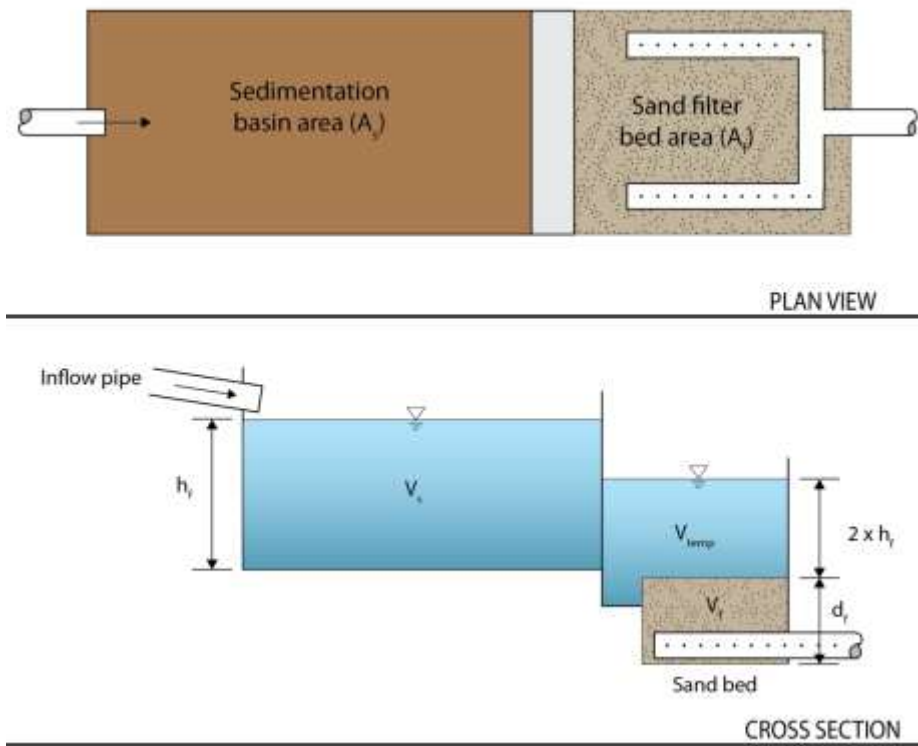

Sand Filter Bed

The filter media consists of an 18-inch layer of clean washed medium sand (meeting ASTM C-33 concrete sand or GDOT Fine Aggregate Size No. 10) on top of the underdrain system. Design should use a sand soil permeability of 3.5 ft/day with a maximum total drain time of 40 hours. [\(10-17\)](#) Darcy's law can be applied to calculate drain time using the hydraulic conductivity of the filter media.

$$q = \frac{KhA}{12L} \tag{10.6.6-4}$$

Where:

- q = flow rate (ft³/hr)
- K = hydraulic conductivity of the media (in/hr)
- h = average head during drawdown period (ft)
- A = cross-sectional area of flow (ft²)
- L = length of flow path (ft)

The filter media depth may be increased, depending upon targeted pollutant treatment. Table 10.6.6-1 lists the depths at which treatment has been found to occur for various pollutants. [\(10-21\)](#)

If phosphorus is targeted for removal, the media should be analyzed by a soils laboratory to determine the phosphorus content and corresponding phosphorus index (P-index). Media with high phosphorus

levels can export this nutrient into the runoff instead of reducing this potential pollutant. A P-index less than 30 is desirable.

Table 10.6.6-1 Sand filter depth for pollutant treatment

Targeted Pollutant	Minimum Sand Filter Depth (ft)
TP	2
TN	3
Temperature	3-4

Three inches of loose topsoil should be placed over the sand bed. Non-woven plastic filter fabric should be placed both above and below the sand bed to prevent clogging of the sand filter and the underdrain system.

The structure of the surface sand filter may be constructed of impermeable media, such as concrete, or through the use of excavations and earthen embankments. When constructed with earthen walls/embankments, filter fabric should be used to line the bottom and side slopes of the sand filter before installation of the underdrain system and filter media.

Flow Bypass Structure

Sand filters should generally be an off-line BMP where the WQ_v is diverted to the filter through a flow bypass structure. Stormwater flows greater than the WQ_v may be diverted. See section 10.8.2 of this manual for further guidance.

Pretreatment/Inlets

The sedimentation chamber acts as pretreatment. Energy dissipation should be provided at all sand filter inlets. Non-erosive velocities are required for flow from the sedimentation chamber to the filtration chamber. See section 10.8 of this manual for further design guidance.

Underdrain System

Underdrains should be a minimum 8-inch perforated polyethylene pipe used to drain and discharge the treated stormwater from the filter media. Multiple branches of underdrain pipe may be utilized when needed. Spacing between branches should be no greater than 10 feet. Darcy's law can be used to determine the maximum flow rate through the filter media. Manning's equation can then be used to verify adequate underdrain pipe diameter. The orifice equation can then be used to determine an adequate length of underdrain pipe.

Cleanouts should be provided at the end of each underdrain branch and should extend to a height that minimizes inflow in the event that a cap is removed or damaged, buried by sediment, or damaged by maintenance equipment.

Refer to Supplemental Specification on Post Construction Stormwater BMP Items and section 10.8.3 of this manual for further design guidance.

Outlet Structure

Treated stormwater will exit the sand filter system through an outlet pipe from the underdrain system to the discharge point. The discharge point of the outlet pipe should be evaluated to determine if there is need for energy dissipation, but the slow rate of filtration generally makes it unnecessary.

An outlet control structure, emergency, or bypass spillway must also be included in the sand filter system design to safely pass flows above the design storm. This prevents water levels within the filter from overtopping the embankment and causing structural damage. Downstream structures should not be impacted by spillway discharges. Typically, other structural controls must be designed in combination with the sand filter to provide safe passage of the CP_v , Q_{p25} , and Q_f . The peak flow of the proposed conditions peak for Q_{p25} must be limited to existing conditions flow rates. See the GDOT Sand Filter Outlet Structure Special Construction Detail for further design guidance

Vegetation

Surface filters should be designed with a grass cover to aid in pollutant removal and prevent clogging. The grass should be capable of withstanding frequent periods of wet and dry.

Additional Design Considerations

To prevent access and address safety concerns, fencing around the perimeter of a surface sand filter and gate locks may be incorporated into the design. Fencing should be determined on a case by case basis as warranted and as allowed by GDOT, see section 10.10 for additional information.

Additional design considerations include compliance with regulatory agencies. No exfiltration is allowed in areas subject to aquifer protection by the EPD watershed protection branch. Impermeable liner on earthen structures and watertight structures should be used. Evaluation of stream warming potential on downstream trout waters may warrant a shorter drain time of 24 hours or the incorporation of a micropool extended detention (ED) pond. Refer to the GSMM for further guidance on micropool ED pond design guidance. For more information on the design of a sand filter, see the detailed calculation example located at the end of this section.

Sand Filter Sizing

1. Determine the goals and primary function of the sand filter.

The goals and primary function of the BMP must take into account any restrictions or site-specific constraints. Also take into consideration any special surface water or watershed requirements.

- Sand filters do not provide runoff reduction volume credits, so the BMP must be sized utilizing the water quality treatment approach.
- Consider if the BMP can be “oversized” to include the channel protection volume.

2. Calculate the Target Water Quality Volume

Calculate the water quality volume formula using the following formula:

$$WQ_v = \frac{1.2 \text{ in} \times (R_v) \times A \times 43560 \frac{ft^2}{acre}}{12 \frac{in}{ft}}$$

Where:

WQ_v = water quality volume (ft³)

R_v = volumetric runoff coefficient. See section 10.4 for volumetric runoff coefficient calculations.

A = onsite drainage area of the post-condition basin (acres)

3. Size flow diversion structure, if needed.

A flow regulator (or flow splitter diversion structure) should be supplied to divert the WQ_v to the sand filter facility. The peak rate of discharge for the water quality design storm is needed for sizing of off-line diversion structures. Refer to section 10.4.1.2 for calculation steps. Size low flow orifice, weir, or other device to pass Q_{wq} .

4. Compute the required surface area of the filter bed.

The filter area is sized using the following equation (based on Darcy's Law):

$$A_f = \frac{WQ_v d_f}{k(h_f + d_f)t_f}$$

Where:

A_f = Surface area of filter bed (ft²)

d_f = Filter bed depth, sand only (ft)

k = Coefficient of permeability of filter media (ft/day) (3.5 ft/day for sand)

h_f = Average height of water above filter bed (ft)

(1/2 h_{max} , which varies based on design but h_{max} typically \leq 6 feet)

t_f = Design filter bed drain time (days)

(1.67 days or 40 hours recommended maximum)

5. Size sedimentation chamber.

The sedimentation chamber should be sized to at least 25% of the computed WQ_v and have a length-to-width ratio of 2:1. The Camp-Hazen equation is used to compute the required surface area:

$$A_s = -\frac{Q_o}{w} \times \ln(1 - E)$$

Where:

A_s = Sedimentation chamber surface area (ft²)

Q_o = Rate of WQ_v outflow over 24 hours (ft³/s)

w = Particle settling velocity (ft³/s)

= 0.0033 ft/s for imperviousness \geq 75%

= 0.0004 ft/s for imperviousness $<$ 75%

E = Trap efficiency (may use 90% trap efficiency (0.9))

6. Compute V_{min}

$$V_{min} = 0.75 \times WQ_v$$

7. Compute the water volume within the filter bed/gravel/pipe, V_f .

$$V_f = A_f d_f n$$

Where:

- V_f = Filter bed voids volume (ft³)
- A_f = Surface area of the filter media (ft²)
- d_f = Depth of filter media (ft)
- n = Porosity (0.4 for most applications)

8. Compute the temporary storage volume above the filter bed, V_{temp} .

$$V_{temp} = 2 \times h_f \times A_f$$

Where:

- V_{temp} = Temporary volume stored above the filter bed (ft³)
- h_f = Average water depth above filter media (ft)

9. Compute the volume within the sedimentation chamber, V_s .

$$V_s = V_{min} - V_f - V_{temp}$$

10. Compute the sedimentation chamber height, h_s .

$$h_s = \frac{V_s}{A_s}$$

11. Ensure h_s and h_f fit available head and other dimensions still fit. Change as necessary in design iterations until all site dimensions fit.
12. Size distribution chamber and riprap berm to spread flow over filtration media.
13. Design inlets, pretreatment facilities, underdrain system, and outlet structures.

Plan inlet protection for overflow from sedimentation chamber and size overflow weir at elevation h_f in filtration chamber to handle surcharge of flow through filter system from 25-year storm.

Maintenance Considerations

Without proper maintenance, BMPs will function at a reduced capacity and may cease to function altogether. A properly designed BMP includes several considerations for maintenance:

- Provide adequate right-of-way.
- Provide access roads and ramps for appropriate vehicles and equipment to all applicable components (outlet structure, forebay, etc.). Maintenance access must include sufficient space to easily replace the upper layers (vegetation, topsoil, and sand) of the filter media.
- Provide space to turn around if necessary.
- Check for sufficient area to safely exit and enter the highway, if applicable.
- If the BMP is fenced, provide appropriately sized gates (refer to section 10.10 for additional guidance regarding fencing and other safety considerations).
- Cleanouts should be provided at the end of each underdrain branch and should extend to a height that minimizes inflow in the event that a cap is removed or damaged, burial by sediment, or damage by maintenance equipment.

Refer to GDOT's *Stormwater System Inspection and Maintenance Manual*, for specific maintenance requirements.

Surface Sand Filter Example Calculation

GIVEN:

- A new roadway project located in Savannah, Georgia.
- The proposed project includes 1,500 feet of roadway (in length).
- Assume that an area approximately 50 feet by 50 feet is available for a sand filter.
- Runoff exits the roadway through a storm drain system with an 18" RCP outlet.
- The site meets all other site constraints.
- The designer has previously calculated the following hydrologic information:
 - $WQ_v = 3,398 \text{ ft}^3$
 - Basin impervious area percentage = 70%

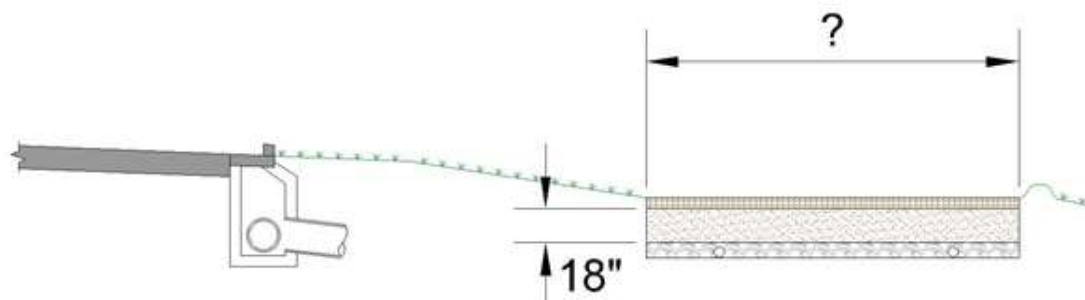

FIND:

- The surface sand filter size and configuration to meet WQ requirements.

SOLUTION:

1. The target water quality volume was already calculated to be 3,398 ft³.
2. Using an 18-inch filter media depth, calculate the required surface area of the sand filter.

$$A_f = \frac{WQ_v d_f}{k(h_f + d_f)t_f}$$

Where:

A_f = Surface area of filter bed (ft²)

d_f = Filter bed depth, sand only (1.5 ft)

k = Coefficient of permeability of filter media (ft/day) (3.5 ft/day for sand)

h_f = Average height of water above filter bed (ft)

(1/2 h_{max} , which varies based on design but h_{max} typically ≤ 6 feet)

t_f = Design filter bed drain time (days)

(1.67 days or 40 hours recommended maximum)

$$A_f = \frac{(3,398 \text{ ft}^3)(1.5 \text{ ft})}{\left(3.5 \frac{\text{ft}}{\text{day}}\right)(3 \text{ ft} + 1.5 \text{ ft})(1.67 \text{ days})} = 194 \text{ ft}^2$$

Approximate constructible dimensions required to form the required area. Use 14 feet by 14 feet for the sand filter surface area, now making $A_f = 196 \text{ ft}^2$.

- Use the following equation to calculate the required surface area of the sedimentation chamber.

$$A_s = -\frac{Q_o}{w} \times \ln(1 - E)$$

Where:

- A_s = Sedimentation chamber surface area (ft^2)
- Q_o = Rate of WQ_v outflow over 24 hours (ft^3/s)
- w = Particle settling velocity (ft^3/s)
= 0.0004 ft/s for imperviousness < 75%
- E = Trap efficiency (may use 90% trap efficiency (0.9))

$$A_s = -\frac{\frac{3,398 \text{ ft}^3}{24 \text{ hrs}} \times \frac{1 \text{ hr}}{3,600 \text{ s}}}{0.0004 \frac{\text{ft}}{\text{s}}} \times \ln(1 - 0.9) = 226 \text{ ft}^2$$

- Compute V_{min} .

$$V_{min} = 0.75 \times WQ_v = 0.75 \times 3,398 \text{ ft}^3 = 2,549 \text{ ft}^3$$

- Compute the water volume within the filter bed.

$$V_f = A_f d_f n$$

Where:

- V_f = Filter bed voids volume (ft^3)
- A_f = Surface area of the filter media (ft^2)
- d_f = Depth of filter media (ft)
- n = Porosity (0.4 for most applications)

$$V_f = 196 \text{ ft}^2(1.5 \text{ ft})(0.4) = 118 \text{ ft}^3$$

- Compute the temporary storage volume above the filter bed, V_{temp} .

$$V_{temp} = 2 \times h_f \times A_f$$

Where:

- V_{temp} = Temporary volume stored above the filter bed (ft^3)
- h_f = Average water depth above filter media (ft)

$$V_{temp} = 2 \times 1.5 \text{ ft} \times 196 \text{ ft}^2 = 588 \text{ ft}^3$$

- Compute the volume within the sedimentation chamber, V_s .

$$V_s = V_{min} - V_f - V_{temp}$$

$$V_s = 2,549 \text{ ft}^3 - 118 \text{ ft}^3 - 588 \text{ ft}^3 = 1,843 \text{ ft}^3$$

The sedimentation chamber (or forebay) should hold a minimum of 25% of the WQ_v but may be larger.

$$25\%(3,398 \text{ ft}^3) = 850 \text{ ft}^3 \leq 1,843 \text{ ft}^3 \therefore OK$$

8. Compute the sedimentation chamber height, h_s .

$$h_s = \frac{V_s}{A_s} = \frac{1,843 \text{ ft}^3}{226 \text{ ft}^2} = 8.2 \text{ ft}$$

A riprap forebay will be used as the sedimentation chamber and its height is limited to 5.5 feet.

Therefore, recalculate the area of the sedimentation chamber using a maximum height of 5.5 feet (new h_s).

$$A_s = \frac{V_s}{h_s} = \frac{1,843 \text{ ft}^3}{5.5 \text{ ft}} = 335 \text{ ft}^2$$

The sedimentation chamber should have a length-to-width ratio of 2:1. For constructability, use minimum 13 feet by 26 feet sedimentation chamber.

A sedimentation chamber that is 13 feet by 26 feet and a sand filter area of 14 feet by 14 feet fit into the available 50 foot by 50 foot area.

Summary

10.6.7 Bioretention Basin



Advantages	Disadvantages
<ul style="list-style-type: none"> • LID/GI design practice • Effective pollutant removals • Low land requirement • No native soil restriction • Appropriate for small areas with high impervious cover • Pleasing aesthetics 	<ul style="list-style-type: none"> • High capital cost • High maintenance burden • Generally limited to drainage areas of 5 acres or less • Not intended for discharge attenuation

Description: Filtration BMP with mulch, diverse vegetation, engineered soil media, and an underdrain.

Design Considerations:

- Drainage area less than 5 acres
- Multiple underdrain options that provide different runoff reduction credits
- Detain the RR_v or treat the WQ_v
- Provide pretreatment to prevent clogging of media
- Ponding depth: 12 inches or less, 9 inches preferred
- Maximum ponding volume drain time of 24 hours
- Engineered soil media is composed of sand, fines, and organic matter
- A landscaping plan is required and vegetation should be carefully selected; trees should not be used

Maintenance Considerations:

- Provide adequate access to the BMP and appropriate components.
- Provide mulch that resists floating to avoid erosion and clogging of the outlet structure.

Applicability for Roadway Projects:

- Well suited for small drainage areas with a high percentage of impervious area
- Low land requirement
- Flexibility in basin shape
- Can be tailored to fit constrained sites

Stormwater Management Suitability

- ✓ Runoff Reduction
- ✓ Water Quality
- Channel Protection
- ✗ Overbank Flood Protection
- ✗ Extreme Flood Protection

✓ Suitable for this practice ○ May provide partial benefits ✗ Not suitable

LID/GI Considerations

Low land requirement, adaptable to many situations, and often a small BMP used to treat runoff close to the source.

Treatment Capabilities

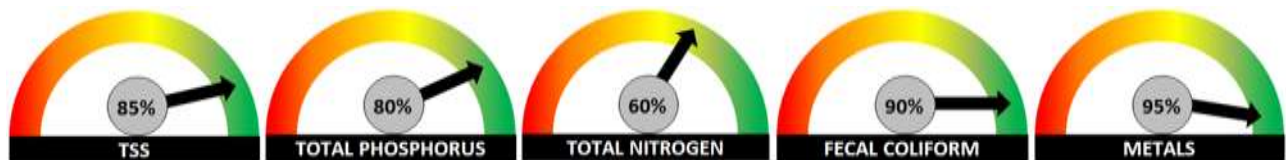

10.6.7 Bioretention Basin

Description

Bioretention basins are structural BMPs that serve to reduce stormwater pollution through infiltration, filtration, biological uptake, and microbial activity using landscape vegetation, engineered soil mix, and an underdrain.

Bioretention basins are effective in reducing TSS, nutrients, heavy metals, pathogens and temperature. After pretreatment, runoff is temporarily detained in the bioretention basin to allow it to percolate through an engineered soil mix. Vegetation is purposefully selected and planted to enhance pollutant removal and aesthetics. If the native soils allow for infiltration, bioretention basins can provide runoff quantity control, particularly for smaller runoff volumes.

The design process of a bioretention basin varies depending on the intended goals and primary function of the basin. If native soils have low infiltration rates, the bioretention basin will be designed to treat the water quality volume. Runoff filters through the engineered soil mix, is collected by the underdrain system, routed to an outlet structure and then discharged through the outlet pipe.

A bioretention basin may be designed with an upturned underdrain within the outlet control structure to create an internal water storage (IWS) zone. An upturned underdrain increases the runoff reduction credit of the BMP and is also a beneficial configuration for nitrogen removal. The IWS maintains a saturated zone where anaerobic conditions develop and increase nitrogen removal. [\(10-30\)](#) The IWS media depth should be at least 12 inches. [\(10-26\)](#)

If native soils allow for infiltration, the bioretention basin can be designed for runoff reduction. When designed for runoff reduction, stormwater runoff filters through the engineered soil mix and then infiltrates into the underlying soil.

The underdrain configuration provided in Figure 10.6.7-1 is a single design that can be used for all bioretention basin designs. Removable screw caps may be included at the underdrain discharge point in the outlet control structure at point A as well as the top of the upturned underdrain at point B, depending on the goals and primary function of the bioretention basin. For a bioretention basin sized for water quality, point B will be capped. For a BMP sized with an IWS zone, point A will be capped, but point B will be open. For a BMP sized for runoff reduction, both points A and B will be capped so that the BMP functions as though no underdrain is present. The underdrain is included in the design in this scenario only as a safety measure to provide a method to drain standing water for maintenance and in the event the BMP does not function as designed.

Bioretention terminology is often confusing and inconsistent. Bioretention BMPs are described as cells, basins, facilities, etc. The term rain garden is sometimes used to describe small, residential bioretention BMPs. Depending on the agency or jurisdiction, an underdrain may be required, allowed, or restricted (filtration versus infiltration).

Figure 10.6.7-1 - Typical bioretention basin configuration

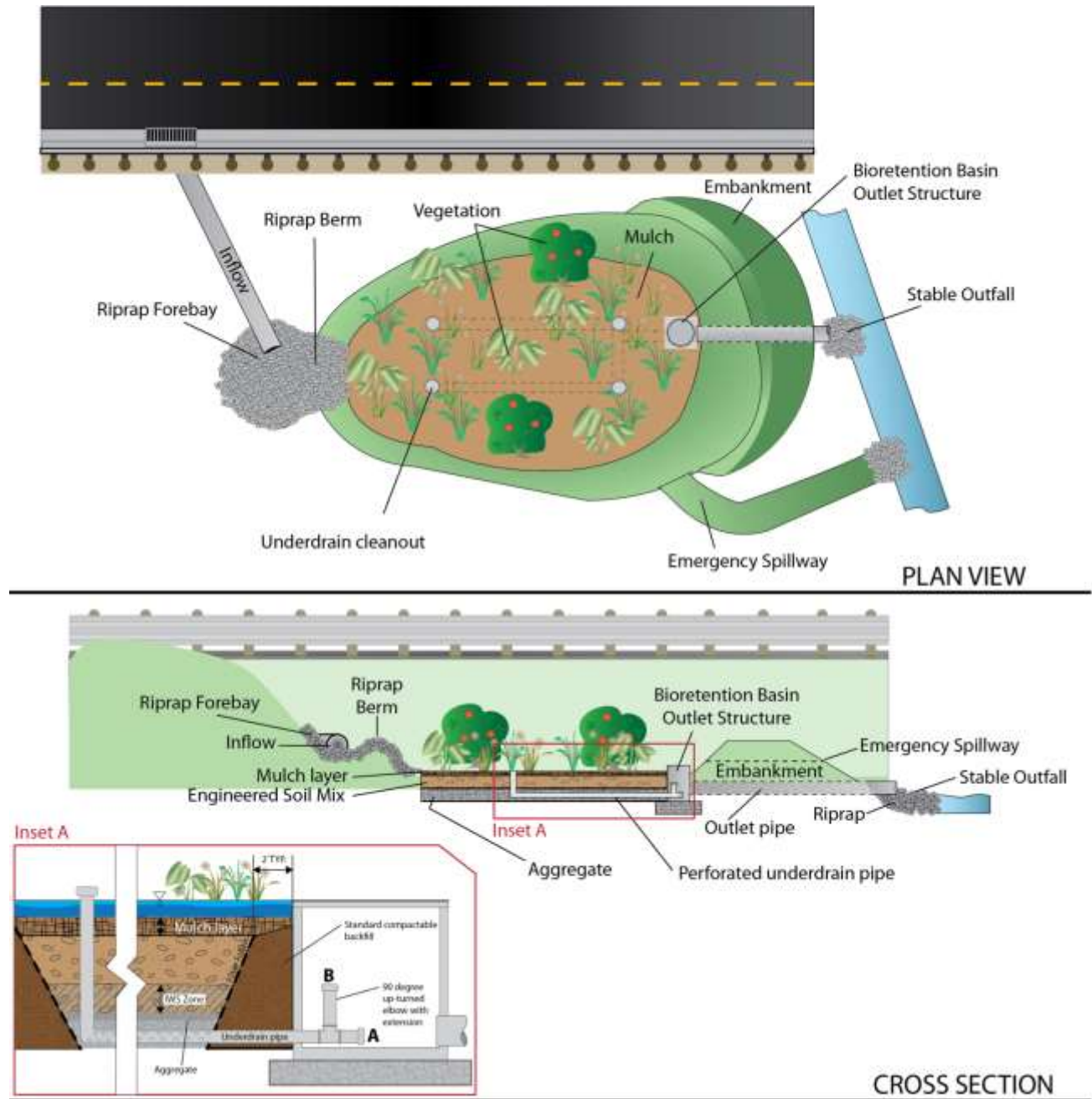

Stormwater Management Suitability

- **Runoff Reduction** – Bioretention basins are one of the most effective low impact development (LID) practices that can be used in Georgia to reduce post-construction stormwater runoff and improve stormwater runoff quality. Like other LID practices, they become even more effective when constructed in native soils with high infiltration rates. A bioretention basin with a capped underdrain can provide 100% of the runoff reduction volume, if properly maintained. In order to design a bioretention basin with a capped underdrain, the footprint must be in HSG A or B

and Worksheet J-1 must find infiltration potentially suitable. Infiltration testing will be performed during construction if the design is for a capped underdrain. A bioretention basin with an upturned underdrain can provide 75% of the runoff reduction volume if the IWS zone is at least equal to the target runoff reduction volume. An upturned underdrain should not be used in soils that have significant clay/rock content due to the clogging potential created during construction. Finally, a bioretention basin with a typical underdrain configuration can provide 50% of the runoff reduction volume, if properly maintained.

- **Water Quality** – A bioretention basin is an excellent stormwater treatment practice due to its variety of pollutant removal mechanisms. The pre-treatment component reduces incoming runoff velocity and filters particulates from the runoff. The ponding area provides for temporary storage of stormwater runoff prior to its evaporation, infiltration, or uptake and provides additional settling capacity. The organic or mulch layer provides filtration as well as an environment conducive to the growth of microorganisms that degrade hydrocarbons and organic material. The engineered soil mix in the bioretention basin acts as a filtration system and clay in the soil provides adsorption sites for hydrocarbons, heavy metals, nutrients and other pollutants. Plants in the ponding area provide vegetative uptake of runoff and pollutants and also serve to stabilize surrounding soils. A bioretention basin with an open or upturned underdrain provides 85% TSS removal if designed, constructed, and maintained correctly. A bioretention basin with a capped underdrain provides 100% TSS removal if designed, constructed, and maintained correctly.
- **Channel Protection** – For smaller sites, a bioretention basin may be designed to capture the entire channel protection volume (CP_v). Given that a bioretention basin is typically designed to completely drain over 72 hours, the requirement of extended detention for the 1-year, 24-hour storm runoff volume will be met. For larger sites, or where only the WQ_v is diverted to the bioretention basin, another control must be used to provide CP_v extended detention.
- **Overbank Flood Protection** – Another control will be required in conjunction with a bioretention basin to reduce the post-development peak flow of the 25-year storm (Q_{p25}) to pre-development levels (detention).
- **Extreme Flood Protection** – Bioretention basins must provide flow diversion and/or be designed to safely pass extreme storm flows and protect the ponding area, mulch layer and vegetation.

Pollutant Removal Capabilities

Bioretention basins designed for runoff reduction with a capped underdrain system are credited with a 100% pollutant removal capability. The following average pollutant removal rates may be utilized for bioretention basins with an open or upturned underdrain:

- TSS – 85% [\(10-28\)](#)
- TP – 80% [\(10-6\)](#)
- TN – 60% [\(10-28\)](#)
- Fecal coliform – 90% [\(10-22\)](#)
- Heavy metals – 95% [\(10-22\)](#)

Bioretention basins that meet the minimum design criteria outlined in this section are expected to perform well and significantly reduce stormwater pollutants. However, where practicable, bioretention basin design should be optimized and tailored to the specific pollutants of concern for the given drainage area and receiving water. Pollutant removal for individual constituents is largely dependent on the media depth provided. For example, pathogens and hydrocarbons are removed at the surface, while temperature reduction typically occurs at 3 to 4 feet of depth. Figure 10.6.7-2 should be used to determine the optimum filtration depth for various pollutants.

Figure 10.6.7-2 - Typical bioretention basin components and treatment processes, and pollutant removal zones (10-26)

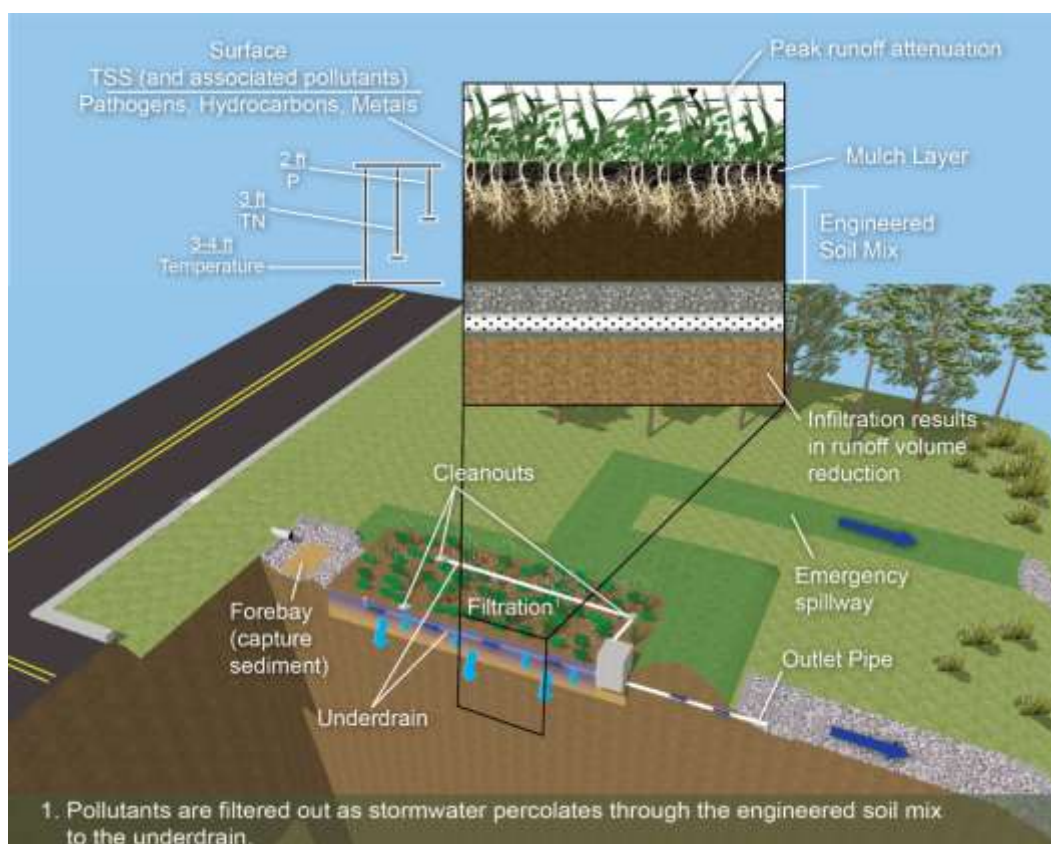

Application and Site Suitability

Bioretention basin designs have been adapted to fit many challenging urban applications. Size, shape, and configuration are flexible and can be adjusted to fit many transportation-related sites. However, due to the added aesthetics and maintenance associated with the landscape vegetation, GDOT bioretention basins may be best suited for highly visible locations such as rest areas, roadway median strips, or municipal interchange quadrants receiving a higher level of maintenance.

When considering locations for a bioretention basin, the following constraints should be considered:

- **Drainage Area** – Due to the limited ponding depths and inlet velocities, bioretention basins usually serve smaller drainage areas (5 acres or less). If the drainage area is greater than 5 acres, consider multiple bioretention basins or providing additional pretreatment and/or inlet

protection to reduce the velocity and energy of stormwater entering the practice. Inlet protection may include splash blocks, a stone diaphragm, a level spreader or another similar device.

- **Space Required** – For general planning purposes, the amount of space that is often needed by the basin is approximately 3 to 6% of the contributing drainage area. The value can vary significantly, however, depending on the design (configuration and components) of the bioretention basin, the percent imperviousness of the drainage area, and the volume of runoff captured.
- **Site Slope** – Bioretention basins are not intended to serve steep contributing slopes. Contributing slopes should be a maximum of 20%, although slopes of 5% or less are ideal.
- **Depth to Water Table** – Two feet of vertical separation from the bottom of the media to the seasonally high water table should be provided to avoid groundwater from ponding inside the filter bed, which could lead to groundwater contamination.
- **Soils** – Determine the HSG from the Web Soil Survey. If the HSG is A or B, and Worksheet J-1 determines that infiltration is potentially suitable, infiltration testing will be performed during construction. Engineered soil mix, as specified in Special Provision 169, is needed.
- **Hotspots** – Do not use for hotspot runoff.
- **Damage to existing structures and facilities** – Consideration should be given to the impact of water exfiltrating the bioretention basin on nearby road bases. To avoid the risk of seepage, bioretention basins should not be hydraulically connected to pavement or structure foundations. [\(10-37\)](#) In addition, the maximum water surface elevation or top of the engineered soil media should not be placed above the subgrade of the adjacent roadway.
- **Setbacks** – Although there are no specific setback requirements, careful consideration should be given to the potential negative impacts for locating bioretention basins in close proximity to water supply wells, septic systems, utilities, and private property. Recommended setbacks are listed below:
 - 10 feet from building foundations
 - 100 feet from private water supply wells
 - 200 feet from public water supply reservoirs (measured from edge of water)
 - 1,200 feet from public water supply wells
- **Trout Stream** – Runoff temperature reduction is provided when a bioretention basin is designed for infiltration. If discharging to a trout stream where temperature is a concern, evaluate for stream warming when an open underdrain system is used.

Data for Design

The initial data needed for bioretention basin design may include the following:

- Existing and proposed site, topographic and location maps, and field reviews
- Aerial photographs of the drainage basin to estimate land use areas (grassed, paved, etc.)

- Preliminary plans including plan view, roadway and drainage profiles, cross sections, and utility plans
- Location of nearby surface waters and the depth to seasonally high groundwater
- Soils data from the Web Soil Survey or other source.
- Design data from nearby hydraulic structures

Flow Bypass Structure

Due to the presence of a mulch layer and engineered soil mix, it may be beneficial to implement the bioretention in an offline configuration using a flow bypass structure. Flows from large storm events can wash out and displace the mulch and media. Refer to section 10.8.2 and the GDOT Bypass Structure Special Construction Detail for additional information.

Pretreatment

Pretreatment is vital to the successful operation of filtration BMPs as the media can quickly become clogged from high sediment loads if otherwise left without pretreatment. Where possible, forebays should be provided. Refer to section 10.8.1 and the GDOT Riprap Forebay Special Construction Detail for additional information guidance on forebays. Filter strips and grass channels can be used for pretreatment in a treatment train application. The location of bioretention basins on unique sites often constrains the use of pretreatment options by application type or available space. Flow exiting the pretreatment device and entering the bioretention basin should be nonerosive to avoid eroding the mulch and engineered soil media.

Filter Media

Bioretention basins have engineered soil mix designed to sustain landscape vegetation and filter pollutants. If the rate of infiltration is too slow, allowing for extended periods of water ponding at the surface, the growth of vegetation will be impeded causing bioretention to be ineffective. Careful consideration is given to the composition of this layer; it is generally engineered and imported from offsite sources. Special Provision 169 prescribes the engineered soil mix to use in bioretention basins. The engineered soil mix should be covered by hardwood mulch that is resistant to floating per Special Provision 169. Mulch provides multiple benefits, such as removing metals and retaining soil moisture.

It is especially important to protect the integrity of the media during construction to prevent clogging or compaction that would reduce its treatment capabilities. Refer to Special Provision 169 for additional construction considerations.

As shown in Figure 10.6.7-2, the depth of the engineered soil mix also plays a role in pollutant removal. The minimum media depth is 24 inches. Additional depth may be added for nitrogen and temperature reduction.

Vegetation

Landscape vegetation is an important design component of bioretention basins. Roots enhance soil qualities and help create a suitable environment for beneficial microbial activity. The vegetation helps to uptake nutrients that have been filtered out of stormwater within the media.

A landscaping plan is required for bioretention basin design. The landscaping plan must include a list of the proposed plant species, source of where the plants are obtained, the planting sequences, and post-nursery maintenance requirements. Vegetation should be selected based on the zone of hydric tolerance. A bioretention basin has essentially three zones. The lowest elevation requires plants that can withstand standing and fluctuating water levels. Plants located in the middle elevation also need to withstand fluctuating water levels but are generally tolerant to dryer conditions. The highest elevation supports plants adapted to dryer conditions. Although trees typically provide added water quality benefits, they can obstruct maintenance operations and roots can damage underdrains. Therefore, tree species are not recommended for use within bioretention basins.

A professional landscape architect may be consulted. Native species are preferred. However, non-native, ornamental species may be used as long as they are not invasive. Vegetation should cover at least 90% of the surface area in the bioretention cell within 2 years. Refer to the GDOT Planting Schedule Special Construction Detail for additional guidance.

Underdrain System

Underdrains collect and convey the stormwater that has filtered through the soil mix. Underdrain systems consist of small diameter perforated pipe surrounded by coarse aggregate. Multiple branches are typically required, and at least two branches are recommended in case one becomes clogged. Refer to section 10.8.3 of this manual and the GDOT Underdrain Special Construction Detail for additional information regarding underdrain design.

Provisions for Overflow

Provisions for overflow should be provided for most bioretention configurations. Exceptions may include small bioretention basins with flow bypass structures. Overflow configurations can include riser boxes and/or emergency spillway channels.

If an elevated catch basin is used, the edge of the inlet should be set at the WQ_v elevation and will perform the same function as would a riser structure in a detention pond. Large riser structures are typically not required in bioretention basins because they typically treat smaller drainage areas. Additional information for both risers and emergency spillway channels can be found in section 10.7, Detention Design and the GDOT Bioretention Basin Outlet Structure Special Construction Detail.

Bioretention Basin Sizing

1. Determine the goals and primary function of the bioretention basin.

The goals and primary function of the BMP must take into account any restrictions or site-specific constraints. Also take into consideration any special surface water or watershed requirements.

- Determine whether the bioretention basin is intended to meet the runoff reduction target or channel protection volume. Please note that bioretention basins have approximately the same size when sized for the runoff reduction volume compared to

when they are sized for the water quality volume, so the default calculations are for runoff reduction, regardless of the HSG. However, be sure to indicate in the plans whether construction should perform infiltration testing.

2. Determine if the bioretention basin will be on-line or off-line. If the bioretention basin will be off-line, a flow regulator (or flow splitter diversion structure) should be supplied to divert the RR_v or CP_v to the bioretention basin. The design storm peak flow is needed for sizing an off-line diversion structure. See section 10.8.2 for more information on bypass structures. See section 10.4.1.2 for more information on calculating the water quality volume peak flow.

3A. Calculate the Stormwater Runoff Reduction Target Volume.

$$RR_v = \frac{1 \text{ in} \times (R_v) \times A \times 43560 \frac{\text{ft}^2}{\text{acre}}}{12 \frac{\text{in}}{\text{ft}}}$$

Where:

$RR_{v(\text{target})}$ = runoff reduction target volume (ft^3)

A = area draining to this practice (acres)

R_v = volumetric runoff coefficient. See section 10.4 for volumetric runoff coefficient calculations.

3B. Determine the storage volume of the practice and the pretreatment volume

The actual volume provided in the bioretention basin is calculated using the following formula:

$$VP = PV + VES(N_{ES}) + VA(N_A)$$

Where:

VP = volume provided (temporary storage)

PV = ponding volume

VES = volume of engineered soils

N_{ES} = porosity of engineered soil (For bioretention basins, use 0.25)

VA = volume of aggregate

N_A = porosity of aggregate (use 0.4)

Provide pretreatment by using a grass filter strip or as needed (sheet flow), or a grass channel or forebay (concentrated flow). Where filter strips are used, 100% of the runoff should flow across the filter strip. Pretreatment is also necessary to reduce flow velocities and assist in sediment removal and maintenance. Pretreatment can include a forebay, weir, or check dam. Splash blocks or level spreaders should be considered to dissipate concentrated stormwater runoff at the inlet and prevent scour. Forebays should be sized to contain 0.1 inches per impervious acre of contributing drainage.

3C. Verify total volume provided by the practice is at least equal to the $RR_{v(\text{target})}$

When the $VP \geq RR_{v(\text{target})}$ then the runoff reduction requirements are met for this practice. When the $VP < RR_{v(\text{target})}$, then the design must be adjusted, the BMP must be sized according to the WQ_v treatment method (see Step 4), or another BMP must be considered and designed.

3D. Verify that the bioretention basin will drain in the specified timeframes.

The ponding area of the bioretention basin must drain within 24 hours (1 day) and the entire bioretention basin must drain within 72 hours (3 days).

$$t_f = \frac{PV(d_f)}{k(h_f + d_f)A_f}$$

Where:

A_f = top surface area of filter media (ft²)

PV = ponding volume (ft³)

d_f = filter media depth (ft)

k = hydraulic conductivity (2 ft/day)

h_f = average water depth (ft)

t_f = drain time (days)

If the HSG is A or B and Worksheet J-1 indicates that infiltration is potentially suitable, verify that the entire volume provided by the BMP will drain within 72 hours.

$$t_f = \frac{VP}{(k_{design})A_a}$$

Where:

VP = total volume provided by practice (ft³)

k_{design} = design infiltration rate of underlying soil (2 ft/day).

A_a = bottom surface area of aggregate (ft²)

4. Design outlet control structure and emergency overflow

An overflow must be provided to bypass and/or convey larger flows to the downstream drainage system or stabilized watercourse. Non-erosive velocities need to be ensured at the outlet point. The overflow should be sized to safely pass the peak flows anticipated to reach the practice, up to a 100-year storm event.

5. Prepare a vegetation and landscaping plan

A landscaping plan for the bioretention basin should be prepared to indicate how vegetation will be established. See the Vegetation section above and the GDOT Planting Schedule Special Construction Detail for additional guidance.

Maintenance Considerations

Without proper maintenance, BMPs will function at a reduced capacity and may cease to function altogether. A properly designed bioretention basin includes the following considerations to facilitate maintenance:

- Access:
 - Provide adequate right-of-way.
 - Provide access roads and ramps for appropriate equipment to all applicable components (outlet structure, forebay, etc.).
 - Provide space to turn around if necessary.

- Check for sufficient area to safely exit and enter the highway, if applicable.
- If the BMP is fenced, provide appropriately sized gates (refer to section 10.10 for additional guidance regarding fencing and other safety considerations).
- Avoid outlet structure configurations that are prone to clogging.
- Hardwood mulch resistant to floating should be used to minimize loss of mulch that results in clogging of the outlet structure.

Refer to GDOT's Stormwater System Inspection and Maintenance Manual, for specific maintenance requirements.

Bioretention Example Calculation

GIVEN:

- A new roadway project located in Savannah, Georgia.
- The proposed project includes 1,100 feet of roadway (in length).
- The drainage area that discharges to the bioretention basin includes the following: two 12-foot lanes and two 3-foot shoulders that will be conveyed via curb and gutter.
- An area, approximately 50 feet by 50 feet, is available for the bioretention basin taking into account access for maintenance and required clear zones.
- Runoff exits the roadway through storm drain system with an 18" RCP outlet.
- The site satisfies all other site constraints.
- Assume CP_v , Q_{p25} and Q_f requirements do not apply.
- HSG A
- The designer has previously calculated the following hydrologic information (See section 10.4 for additional guidance):
 - $RR_v = 2,832 \text{ ft}^3$
 - $WQ_v = 3,398 \text{ ft}^3$

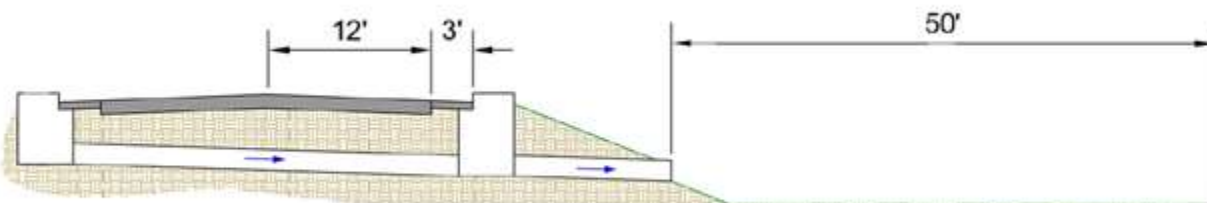

FIND:

- The bioretention size and configuration to retain the RR_v .

SOLUTION:

1. Determine whether the bioretention basin is intended to meet the runoff reduction target or water quality target. Initially, review the infiltration rate of the native soils using the Web Soil Survey and use Worksheet J-1 to determine if it should be indicated on the plans that infiltration testing is needed during construction.
2. The runoff reduction volume was already calculated as 2,832 ft³.
3. The next step is to determine the storage volume of the practice. To complete this step, use the area available as a starting point for the surface area of the bioretention basin. In this example, approximately 50 feet by 50 feet is available for the bioretention basin. It is recommended that a software program and/or BMP sizing calculator spreadsheet be used at this point. The volume provided by the BMP is calculated using the following formula:

$$VP = PV + VES(N_{ES}) + VA(N_A)$$

Where:

VP = volume provided (temporary storage)

PV = ponding volume

VES = volume of engineered soils

N_{ES} = porosity of engineered soil (For bioretention basins, use 0.25)

VA = volume of aggregate

N_A = porosity of aggregate (use 0.4)

Therefore, at least an estimate of the following values is required to calculate the storage volume of the BMP:

- Top surface area of ponding volume
- Bottom surface area of pond volume/top surface area of engineered soil mix
- Maximum ponding height
- Bottom surface area of the engineered soil mix/top surface area of the aggregate layer
- Engineered soil mix depth
- Bottom surface area of the aggregate layer
- Aggregate layer depth

For the purposes of this example, the following values are used as a starting point for sizing the basin.

- Top surface area of ponding volume = 50 ft x 50 ft = 2,500 ft²
- Top surface area of engineered soil mix = 42.5 ft x 42.5 ft = 1,806 ft²
- Maximum ponding height = 12 inches = 1 ft
- Bottom surface area of the engineered soil mix/top surface area of the aggregate layer = 38.5 ft x 38.5 ft = 1,482 ft²
- Engineered soil mix depth = 24 inches = 2 ft
- Bottom surface area of the aggregate layer = 36.2 ft x 36.2 ft = 1,310 ft²
- Aggregate layer depth = 14 inches = 1.167 ft

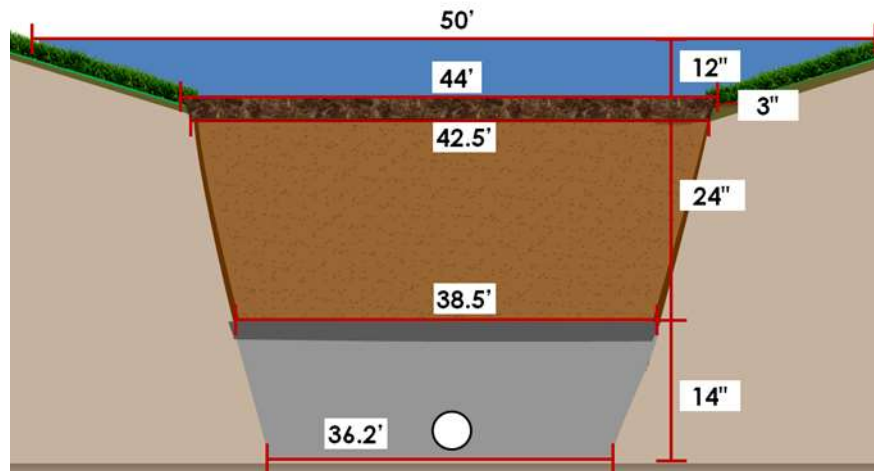

The volume of each layer is approximately the following:

- Ponding volume = 2,218 ft³
- Engineered soils = 3,288 ft³
- Aggregate = 1,629 ft³

$$VP = PV + VES(N_{ES}) + VA(N_A)$$

$$VP = 2218 + 3,288(0.25) + 1,629(0.4) = 3,692 \text{ ft}^3$$

A forebay is the chosen pretreatment method for this bioretention basin. Forebays should be sized to contain 0.1 inches per impervious acre of contributing drainage. The required forebay volume is 275 ft³.

4. The volume provided (3,692 ft³) is greater than the minimum volume of the practice (2,832 ft³) to meet the runoff reduction requirement. It is now an iterative process to design the bioretention basin so that the volume provided more closely matches the minimum required volume to maximize the efficiency of the design.
5. Verify the ponded volume will drain within 24 hours and the entire bioretention basin will drain within 72 hours. For the purposes of this example, assume the values provided in Step 4 are used for the design.

$$t_f = \frac{PV(d_f)}{k(h_f + d_f)A_f}$$

Where:

- A_f = top surface area of filter media (1,806 ft²)
- PV = ponding volume (2,218 ft³)
- d_f = filter media depth (2 ft)
- k = hydraulic conductivity (2 ft/day)
- h_f = average water depth (0.5 ft)
- t_f = drain time (days)

$$t_f = \frac{2,218(2)}{2(0.5 + 2)1,806} = 0.49 \text{ days} = 11.76 \text{ hours}$$

Therefore, the ponded volume will drain within 24 hours.

Now, verify that the entire volume provided by the BMP will drain within 72 hours.

$$t_f = \frac{VP}{(k_{design})A_a}$$

$$t_f = \frac{3,692}{(2)1,310} = 1.409 \text{ days} = 33.8 \text{ hours}$$

Therefore, the total volume provided by the BMP will drain within 72 hours.

6. Therefore, the 50 feet by 50 feet (2,500 ft²) available area is adequate for the bioretention basin assuming slopes and other site constraints are not limiting.

The shape of the bioretention basin should conform to the available area and site topography.

Additional design considerations:

- Design the flow diversion structure, if needed.
- Design the outlet structure in accordance with the GDOT Bioretention Basin Outlet Structure Special Construction Detail.
- Develop the landscaping plan.

Summary

10.6.8 Dry Detention Basin



Advantages	Disadvantages
<ul style="list-style-type: none"> • May be less costly than other detention BMPs • Space may be utilized for other purposes during dry conditions • Can be used for large and small drainage areas 	<ul style="list-style-type: none"> • Standing water can create a safety concern and may require fencing or guardrail. See section 10.10.2 for information on public safety

Description: A basin designed to attenuate peak flows and completely drains between storm events.

Design Considerations:

- Can be used to comply with CP_v , Q_{p25} , and Q_f requirements; other requirements may apply
- Outflow hydrograph should mimic the predevelopment hydrograph
- Maximum drainage area of 75 acres
- Maximum basin depth should be 10 feet
- Side slopes should be 3:1 or flatter if possible
- Basin bottom should be a minimum of 2 feet above the seasonal high water table

Maintenance Considerations:

- Provide adequate access to the BMP and appropriate components
- Design outlet structure to resist clogging

Applicability for Roadway Projects

- Space and grade requirements may limit applicability in the linear environment
- Basin shape can be elongated to accommodate roadway applications
- May be best suited for interchange areas

Stormwater Management Suitability:

- Runoff Reduction
- Water Quality
- Channel Protection
- Overbank Flood Protection
- Extreme Flood Protection

Suitable for this practice May provide partial benefits Not suitable

LID/GI Considerations

Dry detention is generally not considered LID/GI. However, dry detention basins do provide some infiltration and evapotranspiration. Further, they can be used for small drainage areas close to the source and help to restore predevelopment hydrology.

Treatment Capabilities

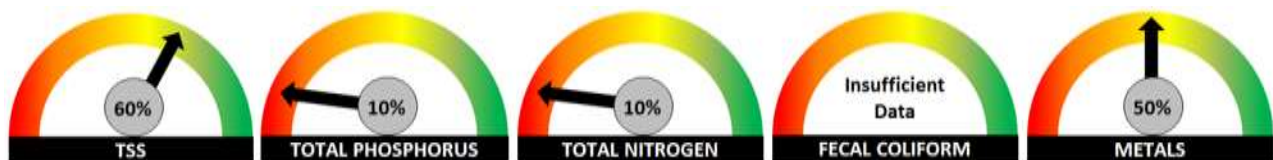

10.6.8 Dry Detention Basin

Description

Dry detention basins are earthen impoundments designed to temporarily store stormwater runoff and drain completely following storm events. Their primary purpose is to reduce the proposed condition rate of discharge (the rate of runoff after final project completion) to the existing condition rate of discharge (the rate of runoff before roadway construction activities begin). Detention may reduce the potential to overload existing downstream drainage systems, reduce the potential for soil erosion, and minimize the adverse effects of sedimentation. Detention basins can be used to help meet WQ_v , CP_v , Q_{p25} , and Q_f requirements. A riser with a small orifice at the bottom allows the basin to temporarily detain the design storm and slowly release it over a period of time (24 hours). Runoff in excess of the design storm is released through additional weirs/orifices higher on the riser, the top of the riser, and/or an emergency spillway channel. Figure 10.6.8-1 illustrates a typical dry detention configuration.

Alternative detention structures include underground detention and multipurpose detention. Underground detention is discouraged for use at GDOT facilities due to the high cost and maintenance burden. However, these facilities may be considered in areas where constraints restrict the use of other BMPs and where flooding may impact life or property. Prior approval is required directly from the Office of Design Policy and Support before designing underground detention facilities. Follow the procedure outlined in section 10.5.3 when submitting for approval to design underground detention or multipurpose detention facilities.

Multipurpose detention areas are facilities that are used primarily for purposes other than detention. Detention can be incorporated into parking lots, rooftops, athletic fields, and other open spaces. Areas of temporarily ponded water are typically shallow, relatively isolated, and graded to drain. Multipurpose detention is generally used for the Q_{p25} and Q_f . Extended detention is precluded because the areas need to be made available for their primary purpose shortly after the rainfall event. Underground and multipurpose detention facilities are covered in greater detail in the GSMM.

Figure 10.6.8-1 - Typical dry detention basin configuration

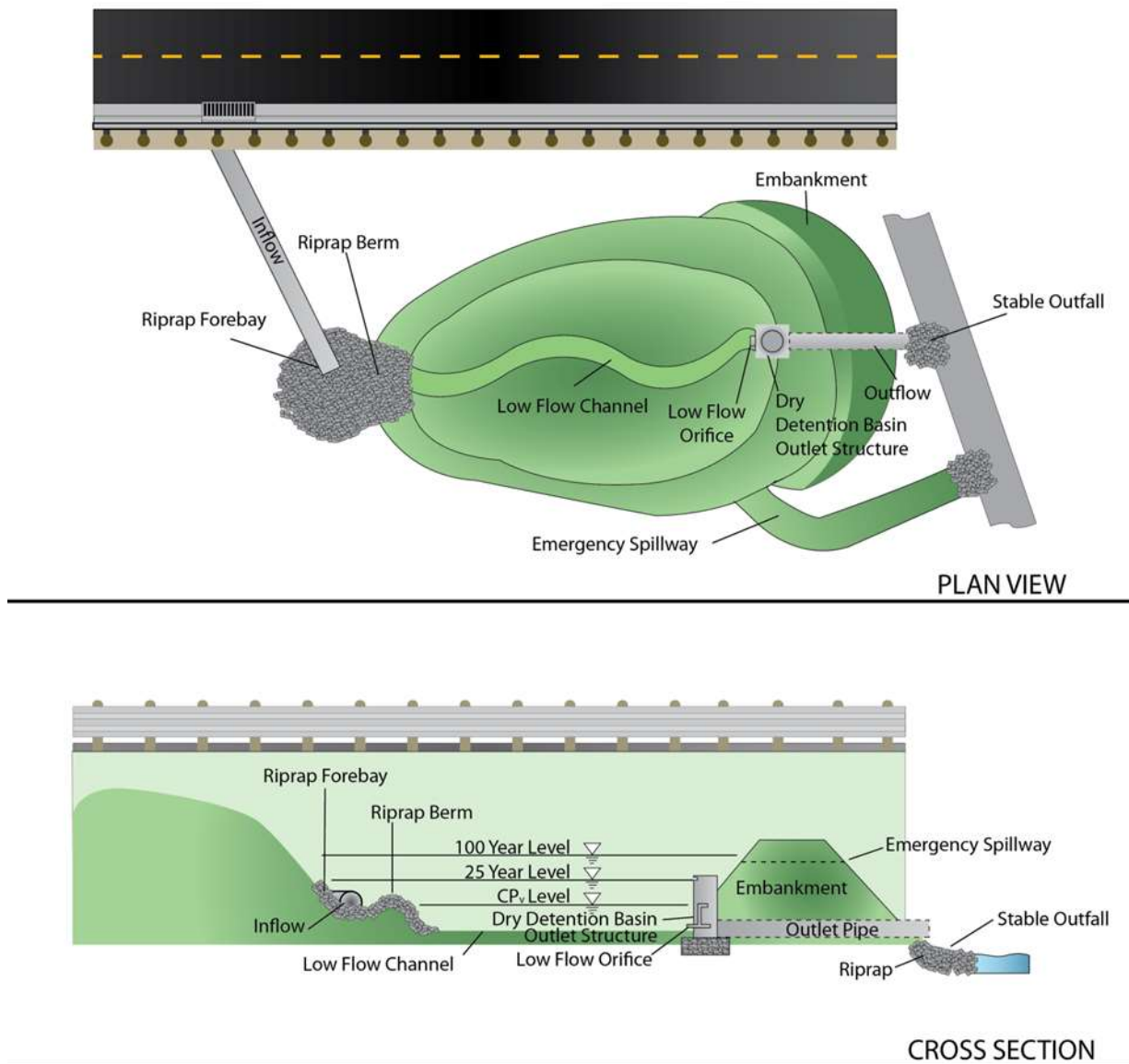

Stormwater Management Suitability

- Runoff Reduction – Another BMP should be used in a treatment train with dry detention basins to provide runoff reduction as they are not designed to provide RR_v as a stand-alone BMP.
- Water Quality – If installed to include the water quality volume and water quality volume orifice per the recommended design criteria and properly maintained, 60% total suspended solids removal will be applied to the water quality volume (WQ_v) flowing to the dry detention basin. Another BMP should be used in a treatment train with dry detention basins..

- Channel Protection – Dry detention basins can be sized to store the channel protection volume (CP_v) and to completely drain over 24-72 hours, meeting the requirement of extended detention of the 1-year, 24-hour stormwater runoff volume.
- Overbank Flood Protection – Dry detention basins are intended to provide overbank flood protection (peak flow reduction of the 25-year, 24-hour storm, Q_{p25}).
- Extreme Flood Protection – Dry detention basins can be designed to control the extreme flood (100-year, 24-hour storm, Q_f) rainfall event.

Pollutant Removal Capabilities

Dry detention basins provide water quality benefits when properly maintained. The following average pollutant removal rates may be utilized for design purposes: [\(10-28\)](#) [\(10-29\)](#)

- TSS - 60%
- TP - 10%
- TN - 30%
- Fecal Coliform - Insufficient Data
- Heavy Metals - 50%

Application and Site Suitability

Dry detention basins should be considered in areas where flooding is a concern. Pre-existing drainage deficiencies such as inadequate downstream channel capacity and flooding conditions should be considered in the overall project design. The construction of dry detention basins within floodplains is strongly discouraged. When the situation is deemed unavoidable, the following must be thoroughly evaluated and shown in the MS4 Post-Construction Stormwater Report:

- The proposed basin functions effectively during the 10-year flood event.
- The proposed basin is structurally sound and safe under the 100-year flood conditions.
- The impacts to the characteristics of the 100-year floodplain due to the basin.

When basin construction is proposed within a floodplain, construction and permitting must comply with all applicable regulations under FEMA's National Flood Insurance Program.

Outlet structures shall not be placed in the clear zone. Guardrail may only be placed for the purpose of protecting a dry detention basin if the BMP is warranted based on one or more of the section 10.2.3 warranting criteria.

In addition to attenuating stormwater runoff, another primary goal of detention design for roadway construction projects is to remove pollutants from the roadway construction activities. Dry detention basins may also reduce the required capacity, and therefore cost, of downstream drainage structures. Figure 10.6.8-2 illustrates typical dry detention basin components and treatment processes.

Figure 10.6.8-2 - Typical dry detention basin components and treatment processes

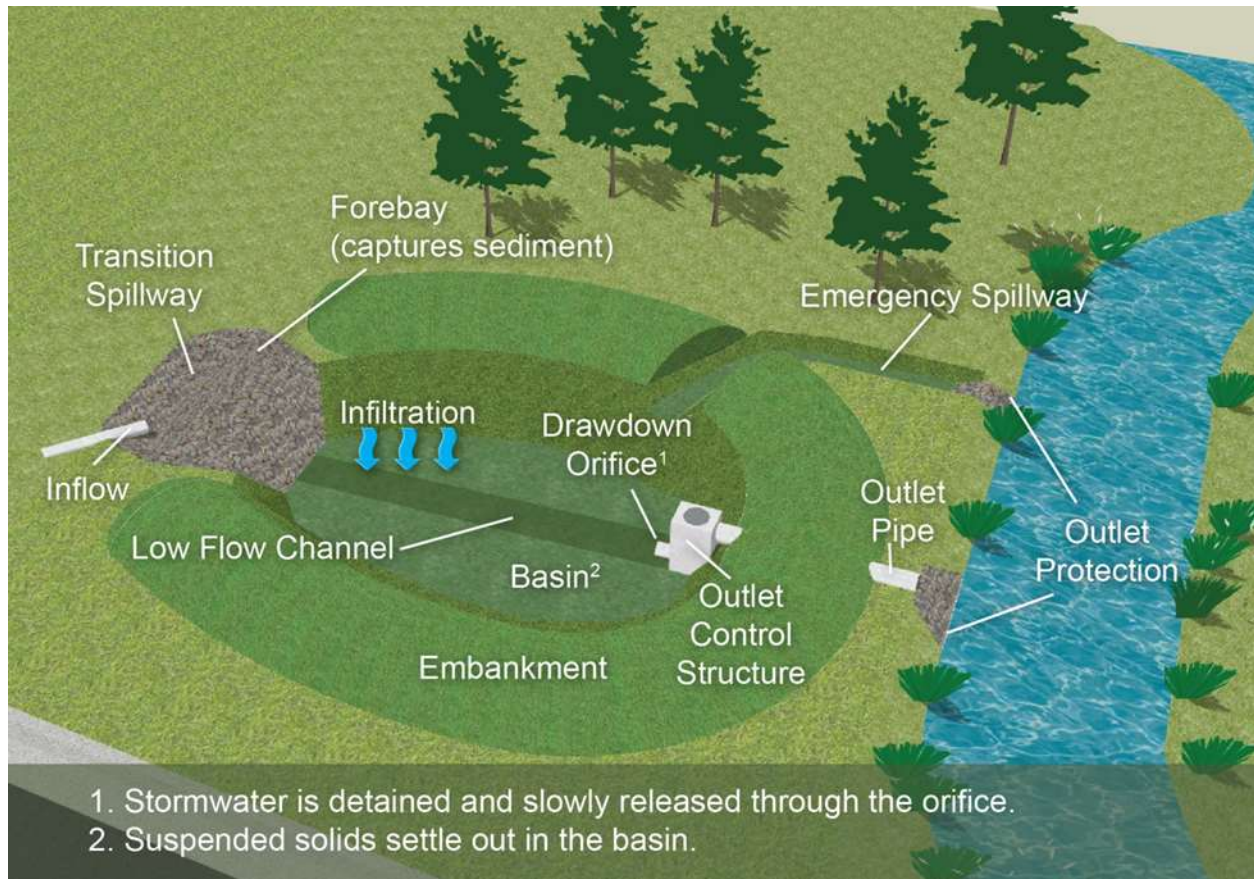

The location of the dry detention basin should be determined by considering a number of factors including: topography, cost, surrounding land use and development, and access. The location should be determined on a case-by-case basis using sound engineering judgment. As a general rule, detention basins should not be located in wetlands or other environmentally sensitive areas such as live streams. Under special circumstances, post-construction BMPs may be allowed within environmentally sensitive areas with prior consent from appropriate regulatory agencies. Siting information and constraints include:

- **Drainage Area** – Limit the contributing drainage area to 75 acres.
- **Site Slope** – Can be used on site with slopes up to about 15%.
- **Bedrock** – Avoid areas with shallow bedrock.
- **Depth to Water Table** – The bottom of the pond should have a minimum of 2 feet of separation from the seasonally high water table if over a water supply aquifer.
- **Hot Spots** – Can accept runoff from stormwater hotspots but need significant separation from groundwater when used for this purpose.
- **Trout Stream** – Should not be used were receiving water temperature is a concern. In addition, careful consideration should be given to the potential for perched or raised groundwater levels.

Challenges associated with roadway configurations include limited right-of-way and clear recovery zone requirements. Basins may be elongated to better fit the linear environment, if necessary. In addition, maintenance must be considered during the design and can often be challenging and hazardous for roadway BMPs. It is recommended that basins be designed with at least a 2:1 length to width ration.

Data for Design

The initial data needed for dry detention basin design includes the following:

- Existing and proposed site, topographic and location maps, and field reviews
- Aerial photographs of the drainage basin to estimate land use areas (grassed, paved, etc.)
- Preliminary plans including plan view, roadway and drainage profiles, cross sections, utility plans, and soil report
- Calculations and details from existing nearby detention facilities (if they have a hydrologic effect on the dry detention basin being designed)

The size and configuration of the dry detention basin will depend on stormwater management goals. Typically, detention basins are designed to capture and slowly release the CP_v over 24 hours, maintain the Q_{p25} at existing condition rates, and to adequately control the Q_f . However, one or more of these goals may be waived as described in section 10.4.

After initial data gathering and determining stormwater management requirements, the designer should proceed with an initial basin volume estimate using one of the following four methods as detailed in section 10.7, Detention Design:

- Hydrograph method
- Triangular hydrograph method
- NRCS procedure
- Regression equation

Next, a location and general configuration for the basin should be determined using the following criteria:

- Maximum depth of 10 feet
- Side slopes should be 3:1 or flatter
- Embankment side slopes of up to 2:1 are allowable with 3:1 preferred

After a rough location and configuration are determined, follow the remaining steps outlined in section 10.7, Detention Design, for sizing and hydrograph routing. Then, integrate the remaining BMP components into the design. Remember that the cumulative flow from multiple detention basins within the same watershed can negatively impact receiving waters if hydrograph timing is not considered. Perform a hydrologic analysis for the project's zone of influence as described in section 10.2.3 of this chapter. For more information on the design of a dry detention basin, see the detailed calculation example located at the end of this section.

Pretreatment

Forebays should be provided at basin inlet areas to capture solids before the runoff enters the main basin. This will reduce clogging of drawdown orifices, extend the life of the BMP, and facilitate maintenance. Forebays should be sized for 0.1 inches of runoff per impervious acre. A small weir or transition spillway exiting the forebay may need to be included to direct low flows into the low flow channel.

Refer to section 10.8, Common BMP Components, for further guidance.

Low Flow Channel

A low flow channel constructed of riprap, or preferably a turf reinforcement mat to promote infiltration and interception of suspended sediments, should be provided to reduce the potential of nuisance conditions such as odors, insects, and weeds. Maximize the flow length of the channel by using a sinuous path to promote infiltration. Consider the drainage area size and groundwater levels when sizing the low flow channel. Refer to chapter 5 of this manual for channel design guidance and chapter 9 for additional guidance on rolled erosion control products.

Vegetation

Vegetation within the basin, on the side slopes, on the embankment, and the area immediately surrounding the basin should generally consist of a hearty turfgrass to prevent erosion. Alternatively, shrub species and other herbaceous species may be considered for highly visible areas where aesthetics are a greater concern. Trees are generally discouraged as they inhibit inspection and maintenance, produce debris that can quickly clog orifices, and can lead to the failure of embankments.

Outlet Structure

The configuration of the outlet structure can vary greatly and will depend on stormwater requirements (i.e., WQ_v , CP_v , Q_{p25} , and Q_f). A typical configuration uses a riser/barrel configuration and emergency spillway to meet all requirements. The riser is typically a concrete structure with a low flow orifice at the elevation of the basin bottom for WQ_v treatment. The low flow orifice is used to detain the WQ_v and slowly release it over a 24-hour period. Alternatively, a metal cage with wire mesh and gravel can be used in lieu of a trash screen.

An additional low flow orifice used to detain the CP_v is located at the top of the water quality volume. This orifice should be properly sized and designed to release the difference between the CP_v and WQ_v over a 24-hour period. The minimum orifice size in a dry detention basin is 2 inches.

Weirs located near the top of the riser or the open throat of the riser are typically used to accommodate the Q_{p25} . Outlet protection should also be provided downstream of the outlet structure to protect against erosion (refer to chapter 8 of this manual). Maximum release rates from the outlet structure should be equal or less than existing condition rates, for the storm events that are required to be studied. Refer to the GDOT Dry Detention Basin Outlet Structure Special Construction Detail for more information.

The hydrograph routing procedures and weir and orifice equations outlined in section 10.7 of this chapter are used to size the components of the outlet structure.

The buoyancy of the outlet structure should be determined and offset with proper anchoring and/or concrete. Refer to the American Concrete Pipe Association's (ACPA) document entitled, *Design Data 41 Manhole Flotation* (2008) [\(10-3\)](#) for additional information.

Emergency Spillway

The emergency spillway is generally an open channel constructed in natural ground (as opposed to the embankment) used to safely pass less frequent storms up to the 100-year event and provides an alternate means of conveying flow should the outlet structure not operate as designed or the design storm for the pond is exceeded.

The emergency overflow elevation shall be established at least one (1) foot below the roadway's normal shoulder break point and no less than the 100-year ponding elevation. Refer to the Dry Detention Basin Outlet Structure Special Construction Detail for additional information.

Refer to the guidance given in chapter 5 of this manual for assistance in sizing the channel and determining an appropriate lining material. Alternatively, if an earthen emergency spillway channel is not feasible, the riser structure may be sized to accommodate the 100-year storm event.

Embankment

The embankment is a small earthen dam or fill section used to create the downslope side of the basin. Embankments must be designed to be less than 25 feet in height and detain less than 100 acre-feet in volume. Any pond volume equal to or greater than 10 acre-ft shall be coordinated directly with ODPS. Embankment height is measured from the elevation of the downstream toe to the maximum water storage elevation. Embankments that exceed these limits should be avoided and are subject to the Georgia Safe Dams Act of 1978. [\(10-13\)](#)

Side slopes of 3:1 or flatter are preferred for maintenance and accessibility; however, 2:1 may be acceptable if conditions warrant. Overland flow should be minimized down embankment side slopes. A slope stability analysis is recommended for embankments higher than 10 feet and is required for slopes steeper than 2:1. Appropriate seepage control should be provided according to the size of the embankment and characteristics of the soils and basin configuration. Refer to the NRCS's Agriculture Handbook 590 [\(10-33\)](#) for additional guidance. Since shallow bedrock beneath the embankment may act as a conduit for seepage through the embankment, additional seepage prevention measures may be needed in these areas. Finally, the embankment should have 1 foot of freeboard above the 100-year flood elevation with additional consideration for embankment settlement.

Refer to GDOT Supplemental Specification on Post-Construction Stormwater BMP Items for additional design guidance and construction considerations.

Dry Detention Basin Sizing

1. Determine the goals and primary function of the dry detention basin.

The goals and primary function of the BMP must take into account any restrictions or site-specific constraints. Also take into consideration any special surface water or watershed requirements. Consider whether the dry detention basin is intended to:

- Meet a water quality (treatment) target in addition to providing detention.
- Provide a possible solution to a drainage problem

2. Calculate the Target Water Quality Volume

Calculate the water quality volume formula using the following formula:

$$WQ_v = \frac{1.2 \text{ in} \times (R_v) \times A \times 43560 \frac{\text{ft}^2}{\text{acre}}}{12 \frac{\text{in}}{\text{ft}}}$$

Where:

WQ_v = water quality volume (ft³)

R_v = volumetric runoff coefficient. See section 10.4 for volumetric runoff coefficient calculations.

A = onsite drainage area of the post-condition basin (acres)

3. Calculate the CP_v , Q_{p25} , and Q_f flow rates and volumes.

4. Determine the pretreatment volume.

A sediment forebay is provided at each inlet, unless the inlet provides less than 10% of the total design storm inflow to the basin. The forebay should be sized to contain 0.1 inch per impervious acre of contributing drainage.

5. Design the outlet control structure.

6. Design embankment(s) and spillway(s).

Size the emergency spillway, calculate the 100-year water surface elevation, set the top of the embankment elevation, and analyze safe passage of the Q_f .

7. Investigate potential basin hazard classification.

The design and construction of the dry detention basin may be required to meet the Georgia Dam Safety standards.

8. Prepare a site vegetation and landscaping plan.

A vegetation scheme for the dry detention basin should be prepared to indicate how the basin bottom, side slopes and embankment will be stabilized and established with vegetation. The use of native vegetation is highly recommended for these facilities.

Maintenance Considerations

Without proper maintenance, BMPs will function at a reduced capacity and may cease to function altogether. A properly designed BMP includes the following considerations for maintenance:

- Access:
 - Provide adequate right-of-way.
 - Provide access roads and ramps for appropriate equipment to all applicable components (outlet structure, forebay, etc.).
 - Provide space to turn around if necessary.
 - Check for sufficient area to safely exit and enter the highway, if applicable.

- If the BMP is fenced, provide appropriately sized gates (refer to section 10.8 for additional guidance regarding fencing and other safety considerations).
- Provide a valve or other method for dewatering the basin if deemed appropriate.

Refer to GDOT's *Stormwater System Inspection and Maintenance Manual* for specific maintenance requirements.

Dry Detention Basin Example Calculation

GIVEN:

- A new roadway project located in Savannah, GA.
- The proposed project includes 1,300 feet of roadway (in length).
- The drainage area that discharges to the dry detention basin includes the following: two 12-foot lanes, a 6-foot paved shoulder, and a 20-foot wide grassed area, draining via sheet flow.
- Assume no stormwater is collected as “off-site” or “bypass” runoff.
- Assume the basin depth will be 3 feet for the purposes of this example.
- Note that a separate hydrograph routing example calculation is given to illustrate the calculations associated with the Q_{p25} and Q_r .
- Assume that water quality treatment will be provided upstream (prior to) the detention basin.

FIND:

- Size the dry detention basin and drawdown orifice to capture and release the CP_v over a 24-hour period.

SOLUTION:

1. Since the dry detention basin will not be sized for the water quality volume, the first step is to size the basin by determining CP_v using guidelines and information from section 10.4.2:

$$Q = \frac{(P - 0.2S)^2}{(P + 0.8S)}$$

Where:

Q = accumulated direct runoff (in) (Q = CP_v in this case)

P = accumulated rainfall (in)

S = potential maximum soil retention (in)

$$S = \frac{1000}{CN} - 10$$

Where:

CN = SCS curve number (most drainage areas will require a composite CN)

A comprehensive list of curve numbers is provided in TR-55. A composite curve number should be calculated for multiple land uses. For example:

$$CN_{composite} = \frac{CN_1A_1 + CN_2A_2 + CN_3A_3}{A_1 + A_2 + A_3}$$

Where:

A = surface area

$$CN_{composite} = \frac{(98)(30 \text{ ft} \times 1,300 \text{ ft}) + (69)(20 \text{ ft} \times 1,300 \text{ ft})}{(50 \text{ ft} \times 1,300 \text{ ft})} = 86.4$$

$$S = \frac{1000}{86.4} - 10 = 1.574$$

From NOAA Precipitation Frequency Data Server (Atlas 14):

P (1-yr, 24 -hr Savannah) = 3.86 in

$$CP_v = \frac{(P - 0.2S)^2}{(P + 0.8S)}$$

$$CP_v = \frac{[3.86 - 0.2(1.574)]^2}{[3.86 + 0.8(1.574)]} = 2.46 \text{ inches of runoff}$$

$$CP_v = (2.46 \text{ in}) \left(\frac{1 \text{ ft}}{12 \text{ in}} \right) (1,300 \text{ ft} \times 50 \text{ ft}) = 13,325 \text{ ft}^3 \text{ (required volume)}$$

- The next step is to determine the pretreatment volume. The forebay should be sized to contain 0.1 inch per impervious acre of contributing drainage.

$$V_{\text{pretreat}} = 0.1 \text{ inches} \times \frac{1 \text{ ft}}{12 \text{ inches}} \times (30 \text{ ft} \times 1,300 \text{ ft}) = 325 \text{ ft}^3$$

- Size the orifice to release CP_v in 24 hours. From chapter 4:

$$Q = C_D A \sqrt{2g\Delta H}$$

Where:

Q = Discharge, ft^3/s

C_D = Coefficient of discharge, 0.6 for a sharp-edged orifice

A = Area of the orifice, ft^2

g = Acceleration of gravity = $32.2 \text{ ft}/\text{s}^2$

ΔH = Difference in head across the orifice, ft

The average required flow rate (Q) from the orifice can be determined by dividing the CP_v by the 24-hr detention time.

$$Q = \left(\frac{13,325 \text{ ft}^3}{24 \text{ hr}} \right) \left(\frac{1 \text{ hr}}{60 \text{ min}} \right) \left(\frac{1 \text{ min}}{60 \text{ sec}} \right) = 0.154 \text{ ft}^3/\text{s}$$

The orifice equation can be rearranged to solve for area:

$$A = \frac{Q}{C_D \sqrt{2g\Delta H}}$$

As an approximation, we can use the basin depth of 3 feet to assume an average ΔH of 1.5 ft for the entire 24-hr detention period.

$$A = \frac{0.154}{0.6 \sqrt{2(32.2)(1.5)}} = 0.0261 \text{ ft}^2$$

Finally, assuming a round orifice, the orifice diameter can be determined.

$$D = \left(\frac{4A}{\pi}\right)^{1/2} = 0.182 \text{ ft} = 2.19 \text{ in}$$

The orifice diameter should be no larger than 2.19 inches and should be rounded down to the nearest constructible value. Because the orifice is less than 3 inches in diameter, internal orifice protection should be provided.

Note that detention of the CP_v is not required for discharges less than 2.0 ft³/s under normal circumstances. Using the TR-55 method, peak flow from the 1-yr, 24-hr storm for this site was estimated at 3.4 ft³/s.

Summary

10.6.9 Wet Detention Pond



Advantages	Disadvantages
<ul style="list-style-type: none"> • Provides aesthetic value • Cost-effective BMP that provides good treatment • Provides wildlife habitat 	<ul style="list-style-type: none"> • Requires a large footprint • Difficulties in maintaining the permanent pool may arise • Standing water can create a safety concern. See section 10.10.2 for information on public safety

Description: An earthen pond with permanent pool and temporary storage for attenuating peak flows.

Design Considerations:

- Size to store the WQ_v (part or all of which can be in the permanent pool) plus CP_v and release over 24 hours; other requirements may apply
- Outflow hydrograph should mimic the predevelopment hydrograph
- Drainage area should be between 10 and 75 acres
- Maximum permanent pool depth of 8 feet, 6 feet preferred
- Minimum depth of 3 feet
- Maximum side slopes of 3:1

Maintenance Considerations:

- Provide a means of draining the basin for maintenance activities
- Design outlet structure to resist clogging

Applicability for Roadway Projects:

- Space requirements and flooding concerns may limit applicability in the linear environment
- GDOT does not typically own sufficient right-of-way and property is usually expensive in locations where wet ponds are most desired (urban communities)

Stormwater Management Suitability:

- Runoff Reduction
- Water Quality
- Channel Protection
- Overbank Flood Protection
- Extreme Flood Protection

Suitable for this practice May provide partial benefits Not suitable

LID/GI Considerations

It is generally not practical or cost-effective to design small ponds close to the source of runoff as LID dictates. However, wet ponds employ multiple LID/GI characteristics such as providing infiltration and evapotranspiration. In addition, wet ponds create the opportunity for water harvesting if there is a demand for irrigation on adjacent properties.

Treatment Capabilities

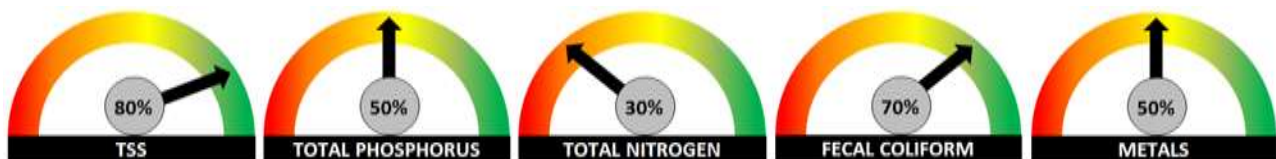

10.6.9 Wet Detention Pond

Description

A wet detention pond is an earthen impoundment that maintains a permanent pool of water and has additional storage for detaining runoff and attenuating peak flows. As such, wet detention ponds provide benefits similar to dry detention basins (i.e., reducing peak flows to existing condition rates and preventing stream channel erosion). Wet detention ponds also provide runoff water quality treatment. The permanent pool provides an area for sediment storage, reducing TSS and the associated pollutants adhered to these particles. Contact with the permanent pool and surrounding vegetation results in chemical and biological processes that reduce nutrients, metals, and pathogens.

Wet detention ponds can be used to meet WQ_v , CP_v , Q_{p25} , and Q_f requirements. A riser with a small orifice that is elevated a few feet off of the basin bottom creates the permanent pool and allows the pond to store additional runoff for a short period of time (24 hours for CP_v). The dimensions of the permanent pool can vary depending on the space available. To address the different stormwater requirements previously listed, the GSMM [\(10-17\)](#) presents multiple types of wet ponds (e.g., wet extended detention pond, micropool extended detention pond). Runoff in excess of the CP_v is released through additional weirs/orifices higher on the riser, the top of the riser, and/or an emergency spillway channel. Figure 10.6.9-1 illustrates a typical wet detention pond configuration.

Figure 10.6.9-1 - Typical wet detention pond configuration

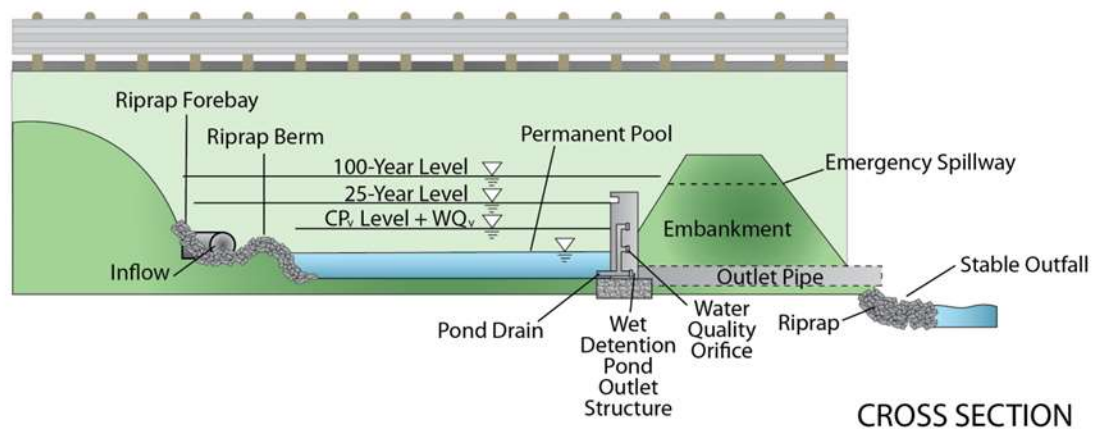
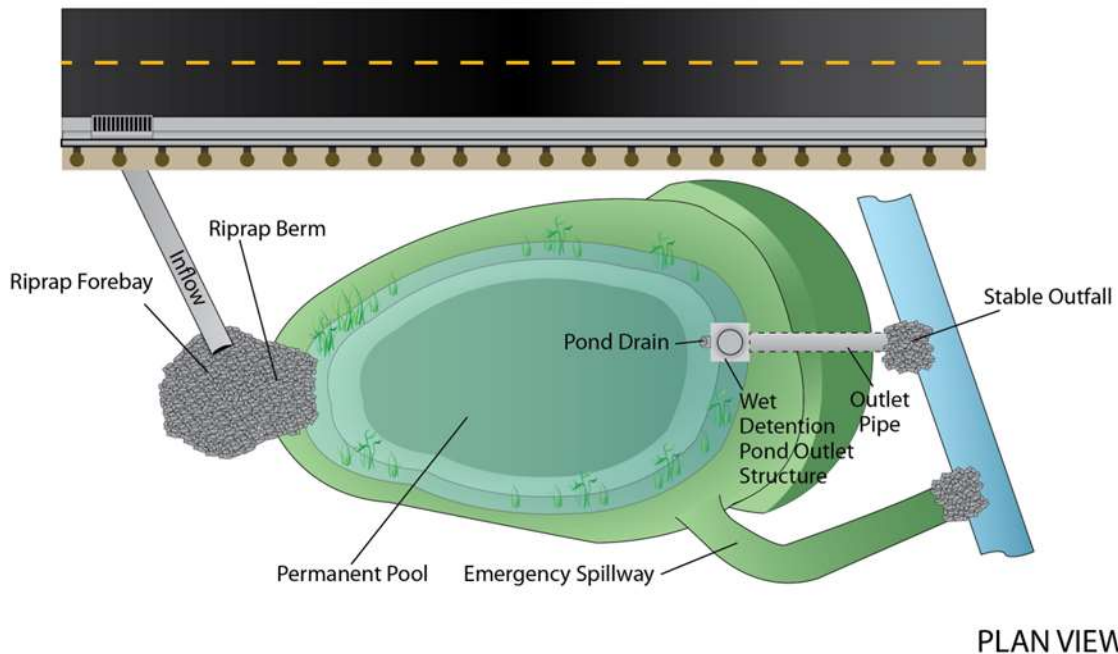

Stormwater Management Suitability

- Runoff Reduction – Wet detention ponds provide negligible stormwater volume runoff reduction. Another BMP should be used in a treatment train with stormwater ponds to provide runoff reduction.
- Water Quality – Wet detention ponds treat incoming stormwater runoff by physical, biological, and chemical processes. The primary removal mechanism is gravitational settling of particulates, organic matter, metals, bacteria, and organics as stormwater runoff resides in the pond. Pollutant removal is also provided through uptake by algae and wetland plants in the permanent pool—particularly of nutrients. Volatilization and chemical activity also work to

break down and eliminate a number of other stormwater contaminants, such as hydrocarbons. A wet detention pond provides 80% TSS removal if designed, constructed, and maintained correctly.

- Channel Protection – A portion of the storage volume above the permanent pool in a wet detention pond can be used to provide control of the channel protection volume (CP_v). This is accomplished by releasing the 1-year, 24-hour storm runoff volume over 24 hours (extended detention).
- Overbank Flood Protection – A stormwater pond can also provide storage above the permanent pool to reduce the post-development peak flow of the 25-year, 24-hour storm (Q_{p25}) to pre-development levels (detention).
- Extreme Flood Protection – In situations where it is required, stormwater ponds can also be used to provide detention to control the 100-year, 24-hour storm peak flow (Q_f). Where this is not required, the pond structure is designed to safely pass extreme storm flows.

Pollutant Removal Capabilities

Wet detention ponds provide good treatment and detention and can be cost-effective BMPs in certain applications. [\(10-17\)](#) The following average pollutant removal rates may be utilized for design purposes: [\(10-17\)](#)

- TSS – 80%
- TP – 50%
- TN – 30%
- Fecal coliform – 70%
- Heavy metals – 50%

Application and Site Suitability

Although they provide many water quality benefits, wet detention ponds are sometimes difficult to implement in roadway settings due to space requirements and safety concerns associated with the permanent pool. Further, an adequate supply of runoff is necessary to maintain the permanent pool. Figure 10.6.9-2 illustrates typical wet detention pond components and treatment processes.

The construction of wet detention ponds within floodplains is strongly discouraged. When the situation is deemed unavoidable, the following must be thoroughly evaluated and shown in the MS4 Post-Construction Stormwater Report:

- The proposed pond functions effectively during the 10-year flood event.
- The proposed pond is structurally sound and safe under the 100-year flood conditions.
- The impacts to the characteristics of the 100-year floodplain due to the pond.

When pond construction is proposed within a floodplain, construction and permitting must comply with all applicable regulations under FEMA's National Flood Insurance Program.

Outlet structures shall not be placed in the clear zone. Guardrail may only be placed for the purpose of protecting a wet detention basin if the BMP is warranted based on one or more of the section 10.2.3 warranting criteria.

Figure 10.6.9-2 - Typical wet detention pond components and treatment processes

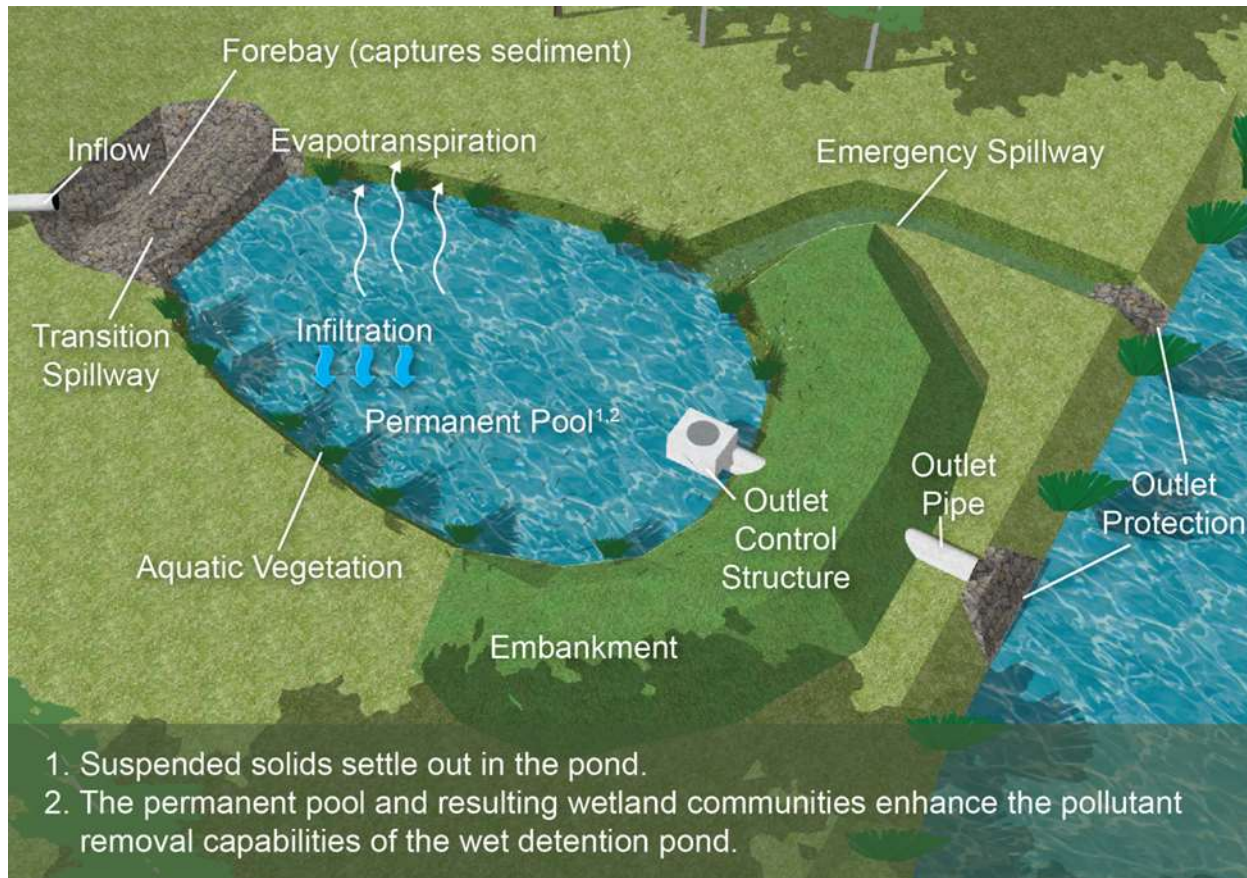

The location of the wet detention pond will be determined by considering a number of factors including topography, cost, surrounding land use and development, and access. The location should be determined on a case-by-case basis using sound engineering judgment. As a general rule, detention ponds should not be located in wetlands or other environmentally-sensitive areas such as live streams. Under special circumstances, post-construction BMPs may be allowed within environmentally sensitive areas with prior consent from appropriate regulatory agencies. Wet pond depths should be varied to meet different objectives. Impacts to adjacent properties resulting from wetland systems requiring shallow depths (e.g., odors, insects) must be evaluated. Alternatively, deep water may be desired to provide a cool water release and/or fish habitat. Siting information and constraints include:

- **Drainage Area** – The contributing drainage area should be limited to 75 acres. Minimum drainage area of 10 acres is required to maintain the permanent pool (unless groundwater is present).
- **Space Required** – The pond usually occupies 2 to 3% of the total drainage area.
- **Depth to Water Table** – A wet detention pond can be used where the water table is at or near the soil surface, or where there is a sufficient water balance in poorly drained soils to support a wetland plant community. If above an aquifer or treating a hotspot, however, 2 feet is required between the bottom of the pond and the elevation of the seasonally high water table. Where wet detention ponds do not intercept the groundwater table, a liner must be installed

on HSG A and B soils. A water balance calculation should be performed to ensure an adequate water budget to support the specified wetland species. A water balance analysis may not be necessary if a liner is installed but should be considered regardless if the drainage area is small and/or has a small amount of impervious area. The wet detention pond size may need to be adjusted to account for lost volume due to seasonal fluctuations in the groundwater table.

- **Site Slope** – There should not be more than 15% slope across the drainage area to the pond.
- **Minimum Head** – 6-8 feet of elevation difference needed onsite from the inflow to the outflow.
- **Setbacks** –
 - Property lines – 10 feet (site development projects only)
 - Private wells – 100 feet
 - Septic systems – 50 feet
 - Public-use airports – 5 miles
- **Trout Stream** – Consideration should be given to the thermal influence of stormwater pond outflows on downstream trout waters. Wet detention ponds can be designed off-line and under shade to minimize their thermal impact.

Challenges associated with roadway configurations include limited right-of-way and clear recovery zone requirements. Basins may be elongated to better fit the linear environment, if necessary. In addition, because it can often be challenging and hazardous to maintain roadway BMPs, maintenance access is an important consideration during BMP design.

Data for Design

The initial data needed for wet detention pond design include the following:

- Existing and proposed site, topographic and location maps, and field reviews
- Aerial photographs of the drainage basin to estimate land use areas (grassed, paved, etc.)
- Preliminary plans including plan view, roadway and drainage profiles, cross sections, utility plans, and soil report
- Calculations and details from existing nearby detention facilities
- Water table information

The size and configuration of the wet detention pond will depend on stormwater management requirements. Typically, wet detention ponds are designed to provide treatment for water quality, capture and slowly release the CP_v over 24 hours, maintain the Q_{p25} at existing condition rates, and to adequately control the Q_f . However, one or more of these goals may be waived as described in section 10.4 of this manual.

After initial data gathering and determination of stormwater management requirements, the designer should proceed with an initial basin volume estimate using one of the following four methods as detailed in section 10.7, Detention Design, in this manual:

- Hydrograph method

- Triangular hydrograph method
- NRCS procedure
- Regression equation

Next, a location and general configuration for the basin should be determined using the following criteria:

- “Permanent pool depths greater than 8 ft are not recommended. If a permanent pool depth greater than 8 ft is proposed, additional approval is required from the Office of Design Policy”.
- Minimum permanent pool depth of 3 feet
- Side slopes should be 3:1 or flatter
- Embankment side slopes of up to 2:1 are allowable with 3:1 preferred
- Minimum length to width ratio of greater than 2:1 is preferred

After a rough location and configuration are determined, follow the remaining steps outlined in section 10.7, Detention Design, for sizing and hydrograph routing. Then, integrate the remaining BMP components into the design. Remember that the cumulative flow from multiple detention facilities within the same watershed can negatively impact receiving waters if hydrograph timing is not considered. Perform a hydrologic analysis for the project’s zone of influence as described in section 10.2.3 of this chapter. For more information on the design of a wet detention pond, see the detailed calculation example located at the end of this section.

Pretreatment

Forebays should be provided at basin inlet areas to capture solids before the runoff enters the main basin. This will reduce clogging of drawdown orifices, extend the life of the BMP, and facilitate maintenance. Forebays should be sized for 0.1 inches of runoff per impervious acre.

Refer to section 10.8, Common BMP Components, for further guidance.

Aquatic and Safety Benches

A safety bench should be provided to help prevent maintenance personnel and the public from slipping into the pond. The safety bench should start at the edge of the permanent pool and extend outward approximately 15 feet (may be less for smaller ponds). The maximum slope of the safety bench should be 6%. The safety bench may be omitted for ponds with side slopes of 4:1 or less. In addition, an aquatic bench should be provided for emergent wetland vegetation. Shallow areas with wetland vegetation provide additional treatment. The aquatic bench should also be approximately 15 feet for average and large ponds. The aquatic bench begins at the edge of the permanent pool and extends inwards to a depth of 12 to 18 inches. Figure 10.6.9-3 provides an illustration of a typical aquatic and safety bench configuration.

Figure 10.6.9-3 - Typical aquatic and safety bench configuration
(adapted from GSMM Vol. 2) (10-17)

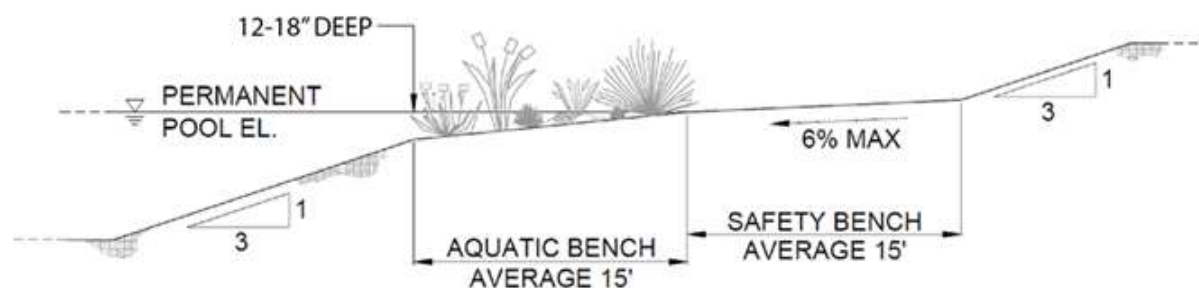

Vegetation

A landscaping plan is required for wet detention pond design. The landscaping plan will include a list of the proposed plant species, source of where the plants are obtained, the planting sequences, and post-nursery maintenance requirements. A professional landscape architect may be consulted.

Vegetation surrounding the normal pool and along the safety bench should be water tolerant wetland species. Native, non-invasive species are preferred. Aquatic vegetation helps remove pollutants and provides wildlife habitat and aesthetic benefits. The remaining areas should generally consist of a hearty turfgrass to prevent erosion. Refer to the GDOT Planting Schedule Special Construction Detail for more information.

Although trees typically provide added water quality benefits, they can obstruct maintenance operations and roots can damage underdrains. Only if conditions allow, taller vegetation and trees may be planted around the wet detention pond to discourage waterfowl from taking residence in the pond as they can add to nutrient and bacteria loads. Woody vegetation (e.g., trees and shrubs) should not be planted on the embankment.

Outlet Structure

The configuration of the outlet structure can vary and will depend on stormwater requirements (i.e., WQ_v , CP_v , Q_{p25} , and Q_f). A typical configuration uses a riser/barrel configuration and emergency spillway to meet all requirements. The riser is typically a concrete structure with a small orifice that is elevated a few feet off of the basin bottom to set the normal pool elevation. The normal pool dimensions can be adjusted so that the BMP will fit within the allowable area. The minimum normal pool volume should be equal to 0.1 inches per impervious acre. For larger areas, the normal pool should be equal to the WQ_v , since this exceeds the 0.1 inches per impervious acre.

The outlet structure should be designed to allow the water level in the pond to rise above the permanent pool elevation as runoff (usually the CP_v) is detained, and then slowly draw it down over 24 hours. This 24-hour period may be reduced to 12 hours where runoff temperature is a concern, near trout streams for example. In addition, the orifice can be positioned lower to draw off cooler water. The minimum orifice size in a wet detention pond is 2 inches.

Weirs created towards the top of the riser, or the open throat of the riser, are typically used to accommodate the Q_{p25} and should be located at an elevation that allows for the storage of the WQ_v and the CP_v . Outlet protection should be provided downstream of the outlet structure to protect

against erosion (refer to chapter 9 of this manual). Maximum release rates from the outlet structure should be targeted towards pre-project rates. The outlet structure contains a small pipe with a threaded end cap at the lowest elevation of the pond in the event that the pond needs to be drained completely. Accessibility to the cap may be difficult at times, depending on the design depth and configuration of the pond, so it is best that the location of the outlet control structure itself be as close to the embankment as possible to accommodate access.

Refer to the GDOT Wet Detention Pond Outlet Structure Special Construction Detail for additional guidance.

The hydrograph routing procedures and weir and orifice equations outlined in section 10.7 of this chapter are used to size the components of the outlet structure.

The buoyancy of the outlet structure should be determined and offset with proper anchoring and/or concrete. Refer to the ACPA document entitled, *Design Data 41 Manhole Flotation* (2008) [\(10-3\)](#) for additional information.

Water Balance

Install an impermeable liner if the wet detention pond is located on HSG A or B soils and the pond does not intercept the groundwater table. A water balance analysis should be performed for systems on HSG C and D soils. Refer to section 10.2.4 for water balance calculations. Infiltration testing will be completed during construction to determine if a liner is needed if the HSG is C or D. Specify the HSG on the plans.

Emergency Spillway

The emergency spillway is generally an open channel constructed in natural ground (as opposed to the embankment) used to safely pass less frequent storms up to the 100-year event and provides an alternate means of conveying flow should the outlet structure become clogged. Refer to the Wet Detention Pond Outlet Structure Special Construction Detail for additional information.

The emergency overflow elevation should be set at the ponding elevation for the 100-year storm event or at least 1 foot below the roadway's normal shoulder break point. Refer to chapter 5 of this manual for channel design guidance. Alternatively, if an earthen emergency spillway channel is not feasible, the riser structure may be sized to accommodate the 100-year storm event.

Embankment

The embankment is a small earthen dam or fill section used to create the downslope side of the basin. Embankments must be designed to be less than 25 feet in height and should detain less than 100 acre-feet in volume. The roadway embankment shall not be used as a dam for impounding water except when the wet detention basin has a volume of less than 5 acre-ft. When this is the case, a 10 ft berm shall be separate the roadway embankment from the top of the basin.

Embankment height is measured from the elevation of the downstream toe to the maximum water storage elevation. Embankments that exceed these limits should be avoided and are subject to the Georgia Safe Dams Act of 1978 (OCGA 12-5-370) [\(10-13\)](#) unless the basin has been excavated and fill was not used to create the dam.

Side slopes of 3:1 or flatter are preferred; however, 2:1 may be acceptable if conditions warrant. Overland flow should be minimized down embankment side slopes. A slope stability analysis is

recommended for embankments higher than 10 feet and is required for slopes steeper than 2:1. Appropriate seepage control should be provided according to the size of the embankment and characteristics of the soils and basin configuration. Refer to the NRCS's Agriculture Handbook 590 (10-33) for additional guidance. Since shallow bedrock beneath the embankment may act as a conduit for seepage through the embankment, additional seepage prevention measures may be needed in these areas. Finally, the embankment should have 1 foot of freeboard above the 100-year flood elevation with additional consideration for embankment settlement.

Refer to GDOT Supplemental Specification on Post-Construction Stormwater BMP Items for additional design guidance and construction considerations.

Wet Detention Pond Sizing

1. Determine the goals and primary function of the wet detention pond.

The goals and primary function of the BMP must take into account any restrictions or site-specific constraints. Also take into consideration any special surface water or watershed requirements.

2. Calculate the Target Water Quality Volume

Calculate the water quality volume formula using the following formula:

$$WQ_v = \frac{1.2 \text{ in} \times (R_v) \times A \times 43560 \frac{\text{ft}^2}{\text{acre}}}{12 \frac{\text{in}}{\text{ft}}}$$

Where:

WQ_v = water quality volume (ft³)

R_v = volumetric runoff coefficient. See section 10.4 for volumetric runoff coefficient calculations.

A = onsite drainage area of the post-condition basin (acres)

3. Determine the permanent pool volume.

- Wet Pond: Size permanent pool volume to 1.0 WQ_v
- Wet ED Pond: Size permanent pool volume to 0.5 WQ_v and extended detention volume to 0.5 WQ_v
- Micropool ED Pond: Size permanent pool volume to 25-30% of WQ_v and extended detention volume to remainder of WQ_v

4. Determine the pretreatment volume.

A sediment forebay is provided at each inlet, unless the inlet provides less than 10% of the total design storm inflow to the basin. The forebay should be sized to contain 0.1 inch per impervious acre of contributing drainage.

5. Determine the pond location and preliminary geometry. Conduct pond grading and determine storage volume available for the permanent pool (and water quality extended detention volume as appropriate).

This step involves initially grading the pond (establishing contours) and determining the elevation-storage relationship for the pond.

- Include safety and aquatic benches
 - Set WQ_v permanent pool elevation (and WQ_v -ED elevation for wet ED and micropool ED ponds)
6. If applicable, complete a water balance analysis to verify the wet detention pond will maintain its permanent pool.
- For the infiltration component of the water balance, the vertical projection of both the side slopes and pond bottom to the pond surface should be used for the permanent pool area to account for infiltration through the side slopes.
7. Compute extended detention orifice release rate(s) and size(s), and establish CP_v elevation.
- Wet Pond: The CP_v elevation is determined from the stage-storage relationship and the orifice is then sized to release the difference between the water quality volume and channel protection storage volume over a 24-hour period (12-hour extended detention may be warranted in some cold water stream basins).
 - Wet ED Pond and Micropool ED Pond: Based on the elevations established in Step 5 for the extended detention portion of the water quality volume, the water quality orifice is sized to release this extended detention volume in 24 hours. The CP_v elevation is then determined from the stage-storage relationship. The invert of the channel protection orifice is located at the water quality extended detention elevation, and the orifice is sized to release the difference between the water quality volume and channel protection storage volume over a 24-hour period (12-hour extended detention may be warranted in some cold water streams).
8. Calculate the Q_{p25} release rate and water surface elevation.
- Set up a stage-storage-discharge relationship for the control structure for the extended detention orifice(s) and the 25-year, 24-hour rainfall event.
9. Design embankment(s) and spillway(s).
- To size the emergency spillway, calculate the 100-year, 24-hour storm water surface elevation. The emergency overflow elevation should be set at the ponding elevation for the 100-year storm event and should be at least 1 foot below the roadway's normal shoulder break point and analyze safe passage of the Extreme Flood Volume (Q_f). At final design, provide safe passage for the 100-year, 24- hour rainfall event.
10. Verify pond embankment design does not trigger Georgia Safe Dams hazard classification.
- Embankments must be designed to be less than 25 feet in height and should detain less than 100 acre-feet in volume. Embankment height is measured from the elevation of the downstream toe to the maximum water storage elevation. Embankments that exceed these limits should be avoided and are subject to the Georgia Safe Dams Act of 1978 (OCGA 12-5-370) [\(10-13\)](#) unless the basin has been excavated and fill was not used to create the dam.
11. Prepare a site vegetation and landscaping plan.
- A landscaping plan for a stormwater pond and its buffer should be prepared to indicate how aquatic and terrestrial areas will be stabilized and established with vegetation. See the GDOT Planting Schedule Special Construction Detail for more information.

Maintenance Considerations

Without proper maintenance, BMPs will function at a reduced capacity and may cease to function altogether. A properly designed BMP includes several considerations for maintenance:

- Access:
 - Provide adequate right-of-way.
 - Provide access roads and ramps for appropriate equipment to all applicable components (outlet structure, forebay, etc.).
 - Provide space to turn around if necessary.
 - Check for sufficient area to safely exit and enter the highway, if applicable.
 - If the BMP is fenced, provide appropriately sized gates (refer to section 10.10 for additional guidance regarding fencing and other safety considerations).
 - Adequate access for a small boat may be needed for sediment depth measurements.

Refer to GDOT's *Stormwater System Inspection and Maintenance Manual*, for specific maintenance requirements

Wet Detention Basin Example Calculation

GIVEN:

- A new roadway project located in Savannah, GA.
- The proposed project includes 3,000 feet of roadway (in length).
- The drainage area that discharges to the wet detention pond includes the following: two 12-foot lanes, two 6-foot paved shoulders, and two 20-foot wide grassed areas (on either side of the road) draining via sheet flow.
- Soil underlying the wet detention basin is sandy clay loam.
- Offsite stormwater also provides supplemental runoff to maintain permanent pool (assume 5 acres (217,800 ft²) of undeveloped land for the purposes of this example).
- Pond dimensions were simplified and assumed for the purposes of this example.
- The designer has previously calculated the following hydrologic information:
 - Min permanent pool = 0.1 inches × Impervious Acreage = 0.021 ac-ft (915 ft³)
 - Upper end permanent pool = $WQ_v = 0.251$ ac-ft (10,934 ft³) (See section 10.4.1.2 for additional guidance)
 - $CP_v = 13,325$ ft³ (See section 10.4.2 for additional guidance)

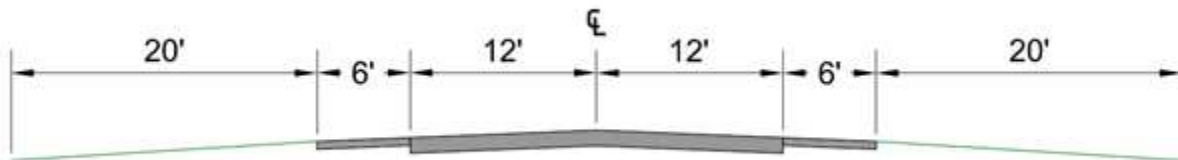

FIND:

- Size the wet detention pond permanent pool, temporary storage, and drawdown orifices to capture and release the WQ_v and CP_v over 24 hours.
- Perform a water balance calculation to verify that the permanent pool will be maintained to an acceptable degree.
- Note that a separate hydrograph routing example calculation is given in section 10.7 to illustrate the calculations associated with the Q_{p25} and Q_f .

SOLUTION:

1. The target water quality volume was already calculated to be 10,934 ft³.
2. The permanent pool can vary anywhere from 915 ft³ to 10,934 ft³. The approximate 10-acre drainage area for this site is relatively small for a wet detention pond and may not support the permanent pool unless groundwater contributes additional baseflow. Therefore, the micropool

(915 ft³) option will be evaluated. Any portion of the WQ_v not accounted for in the permanent pool should be provided for through extended detention.

3. The pretreatment (forebay) volume is calculated as:

$$\text{Forebay volume} = 0.1 \text{ inches} \times \text{Impervious Acreage}$$

$$\text{Forebay volume} = 0.1 \text{ in} \times \frac{36 \text{ ft} \times 3,000 \text{ ft}}{43,560 \frac{\text{ft}^2}{\text{ac}} \times 12 \frac{\text{in}}{\text{ft}}} = 0.021 \text{ ac} - \text{ft} = 915 \text{ ft}^3$$

4. The minimum depth of the permanent pool should be 3 feet with a length to width ratio of at least 2:1. Therefore, the permanent pool dimensions can be approximated at 3 ft deep x 13 ft wide x 26 ft long. The area of the permanent pool is approximately 338 ft² or 0.0078 acres.
5. A **water balance calculation** should be performed to verify that the permanent pool has adequate depth. This example assumes no baseflow. Refer to Table 10.6.9-1:
 - a. Determine the average monthly precipitation for your site.
 - b. Obtain monthly evaporation distribution values from Table 10.2-2
 - c. Calculate the volume of runoff from the contributing drainage area minus the pond (R_o) for each month (*Example calculations below are for January*)

$$I = \frac{36 \text{ ft} \times 3,000 \text{ ft}}{76 \text{ ft} \times 3,000 \text{ ft} + 217,800 \text{ ft}^2} = 24.2\%$$

$$R_v = 0.05 + 0.009(I) = 0.05 + 0.009(24.2) = 0.27$$

$$Q = 0.9PR_v = 0.9(3.69)(0.27) = 0.897 \text{ inches}$$

$$R_o = \frac{QA_{\text{site-pond}}}{12} = \frac{0.897(10.23 \text{ ac} - 0.0078 \text{ ac})}{12} = 0.76 \text{ acre} - \text{ft}$$

- d. Calculate the volume of precipitation that falls on the pond (P_{pond}).

$$P_{\text{pond}} = \frac{P(A_{\text{pond}})}{12} = \frac{3.69(0.0078)}{12} = 0.002 \text{ ac} - \text{ft}$$

- e. Obtain the free water surface evaporation value from Figure 10.2-4. For Savannah, this value is approximately 46 inches.
- f. Calculate the volume of evaporation that occurs over the open water surface of the pond (E).

$$E = \frac{\text{Evap. Dist.} \times \text{Free Water Surface Evaporation} \times A_{\text{pond}}}{12} = \frac{3.2\% \times 46 \times 0.0078}{12} = 0.001 \text{ ac} - \text{ft}$$

- g. Determine the saturated hydraulic conductivity (k_h) of the soil using Table 10.2-1. For sandy clay loam, k_h = 0.34 ft/day.

- h. Calculate infiltration (I). For this example, assume $G_h = 1$.

$$I = Ak_h G_h = 0.0078ac \times \frac{0.34ft}{day} \times 1 \times 31days = 0.082ac - ft$$

- i. Calculate the difference between the inflows and outflows.

$$Balance = (Ro + P_{pond}) - (E + I) = (0.76 + 0.002) - (0.001 + 0.082) = 0.679 ac - ft$$

- j. Calculate the accumulated total. Assume that all volume above the 3-foot depth (0.023 acre-feet) overflows and is lost in the trial design.

Table 10.6.9-1 shows that there are higher inflows than outflows for every month, and the pond can maintain a permanent pool of at least 3 feet.

Table 10.6.9-1. Summary Water Balance Calculations

	Jan	Feb	Mar	Apr	May	Jun	Jul	Aug	Sep	Oct	Nov	Dec
Days/Mo	31	28	31	30	31	30	31	31	30	31	30	31
¹Precip. (in)	3.69	2.79	3.73	3.07	2.98	5.95	5.6	6.56	4.58	3.69	2.37	2.95
Evap. Dist.	3.2%	4.4%	7.4%	10.3%	12.3%	12.9%	13.4%	11.8%	9.3%	7.0%	4.7%	3.2%
Ro (ac-ft)	0.76	0.58	0.77	0.64	0.62	1.23	1.16	1.36	0.95	0.76	0.49	0.61
P_{pond} (ac-ft)	0.002	0.002	0.002	0.002	0.002	0.004	0.004	0.004	0.003	0.002	0.002	0.002
E (ac-ft)	0.001	0.001	0.002	0.003	0.004	0.004	0.004	0.004	0.003	0.002	0.001	0.001
I (ac-ft)	0.082	0.074	0.082	0.079	0.082	0.079	0.082	0.082	0.079	0.082	0.079	0.082
Balance (ac-ft)	0.683	0.504	0.691	0.555	0.533	1.153	1.077	1.277	0.869	0.682	0.412	0.530
Running Balance (ac-ft)	0.023	0.023	0.023	0.023	0.023	0.023	0.023	0.023	0.023	0.023	0.023	0.023

¹<https://www.ncdc.noaa.gov/cdo-web/datatools/normals>

6. Extended Detention (for the remaining WQ_v):

Note that the pretreatment and permanent pool volume can be subtracted from the WQ_v to determine the remaining WQ_v that will be treated through extended detention:

$$WQ_v = 10,934 \text{ ft}^3 - 915 \text{ ft}^3 - 915 \text{ ft}^3 = 9,104 \text{ ft}^3$$

With the addition of the 15-ft wide aquatic bench, the pond dimensions become 28 ft x 41 ft resulting in a depth of approximately 8 ft. This is likely deeper than desired (without considering the CP_v) due to added embankment design challenges and potential safety concerns. Increasing the dimensions to 50 ft x 100 ft results in a depth of 4.5 ft (when looking at the combined WQ_v and CP_v) which is more manageable.

The water quality drawdown device should be positioned on the outlet control structure such that it maintains the 3-foot deep permanent pool. Its orifice should be sized to draw down the WQ_v within 24 hours. See section 10.6.8 for an example that illustrates the orifice sizing process.

7. Channel Protection:

Based on the approximate geometry of the wet detention pond, the portion of the WQ_v treated through extended detention requires a depth of approximately 1.8 feet [$9,104 / (50 \times 100)$]. Therefore, the CP_v drawdown device should be located approximately 1.8 feet above the WQ_v drawdown device and to draw down the CP_v over a 24-hour period.

The pond must be positioned within the available footprint and designed to fit the site's topography. A stage-storage relationship should be established to more accurately represent storage volumes associated with various water surface elevations. The stage-storage relationship will more accurately reflect the pond's side slopes and any irregular topography. The riser and emergency spillway should be designed to control the Q_{p25} and the Q_f . Verify that all other design requirements and constraints have been met.

Summary

10.6.10 Stormwater Wetland



Advantages	Disadvantages
<ul style="list-style-type: none"> • Offers good treatment and provides wildlife habitat • Maintenance requirements are typically minimal 	<ul style="list-style-type: none"> • Requires a large footprint • More costly than some BMPs • Difficulties in maintaining the permanent pool may arise

Description: A shallow impoundment with a permanent pool designed to mimic natural wetlands.

Design Considerations:

- Two design variations (level 1 and level 2) achieve different pollutant removals
- Outflow hydrograph should mimic the existing conditions hydrograph, where applicable
- Minimum preferred drainage area of 5 acres
- Various wetland zones (e.g., deep pools, high marsh) create diverse wetland communities
- The design of stormwater wetlands should include a water balance analysis and landscaping plan

Maintenance Considerations:

- Provide adequate access to the BMP and appropriate components
- Design outlet structure to resist clogging

Applicability for Roadway Projects:

- Space requirements and flooding concerns may limit applicability in the linear environment; however, linear-shaped wetlands can offer many of the same benefits as traditional stormwater wetlands
- May be best suited for low lying, flat areas

Stormwater Management Suitability:

- Runoff Reduction
- Water Quality
- Channel Protection
- Overbank Flood Protection
- Extreme Flood Protection

Suitable for this practice May provide partial benefits Not suitable

LID/GI Considerations

It is generally not practical or cost-effective to design small wetlands close to the source of runoff as LID dictates. However, stormwater wetlands employ several LID/GI characteristics such as mimicking natural systems and providing infiltration and evapotranspiration.

Treatment Capabilities

■ Level 1 Stormwater Wetlands (L1)

■ Level 2 Stormwater Wetlands (L2)



10.6.10 Stormwater Wetland

Description

Stormwater wetlands function similar to wet detention ponds. Stormwater wetlands are earthen impoundments that maintain a permanent pool of water and may have additional storage for detaining runoff and attenuating peak flows. However, stormwater wetlands are shallower than wet detention ponds and have greater areas of wetland vegetation. Varying shallow water depths (wetland zones) increase aquatic plant diversity. Stormwater wetlands can provide detention benefits such as reduced peak flows and preventing stream channel erosion. Stormwater wetlands also provide runoff water quality treatment. The permanent pool provides an area for sediment storage, reducing TSS and the associated pollutants adhered to these particles. Contact with the permanent pool and wetland vegetation results in chemical and biological processes that reduce nutrients, metals, and pathogens.

Recent research and lessons learned during the past 20 years of stormwater wetland implementation have led to additional design recommendations that can enhance the pollutant removal ability and wildlife benefits of stormwater wetlands. This section presents two types of stormwater wetlands. Level 1 wetland designs are based on the stormwater wetland approach presented in the GSMM with some modifications and suggestions based on lessons learned. Level 2 wetland designs are based on guidance from the Center for Watershed Protection. [\(10-8\)](#)

Level 1 stormwater wetlands can be used to meet WQ_v , CP_v , Q_{p25} , and Q_f requirements. A riser with a small orifice that is elevated above the bottom of the wetland creates a shallow permanent pool and allows the wetland to store additional runoff for a short period of time (24 hours for CP_v). Runoff in excess of the design volume is released through the top of the riser and/or an emergency spillway channel. Figure 10.6.10-1 illustrates a typical level 1 stormwater wetland configuration.

Figure 10.6.10-1 - Typical Level 1 stormwater wetland configuration

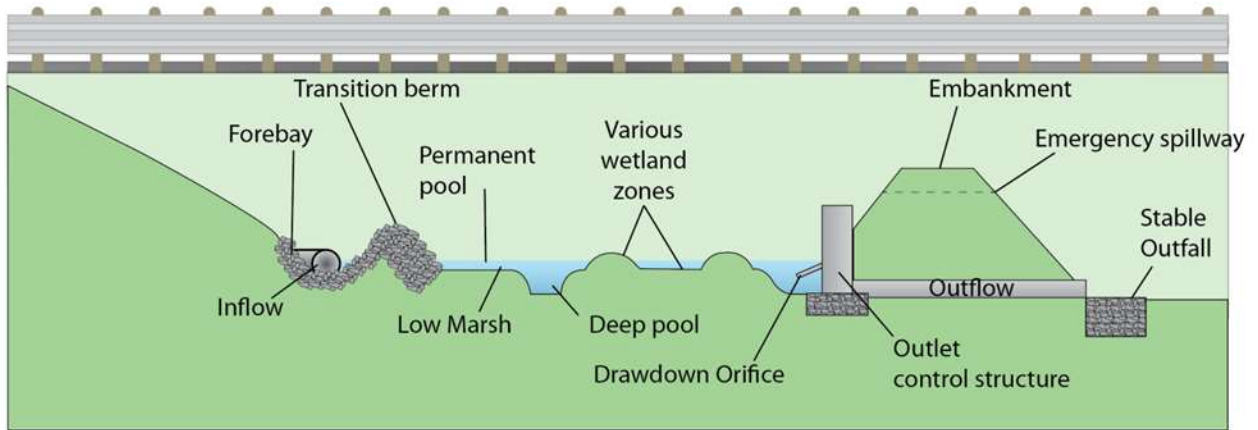
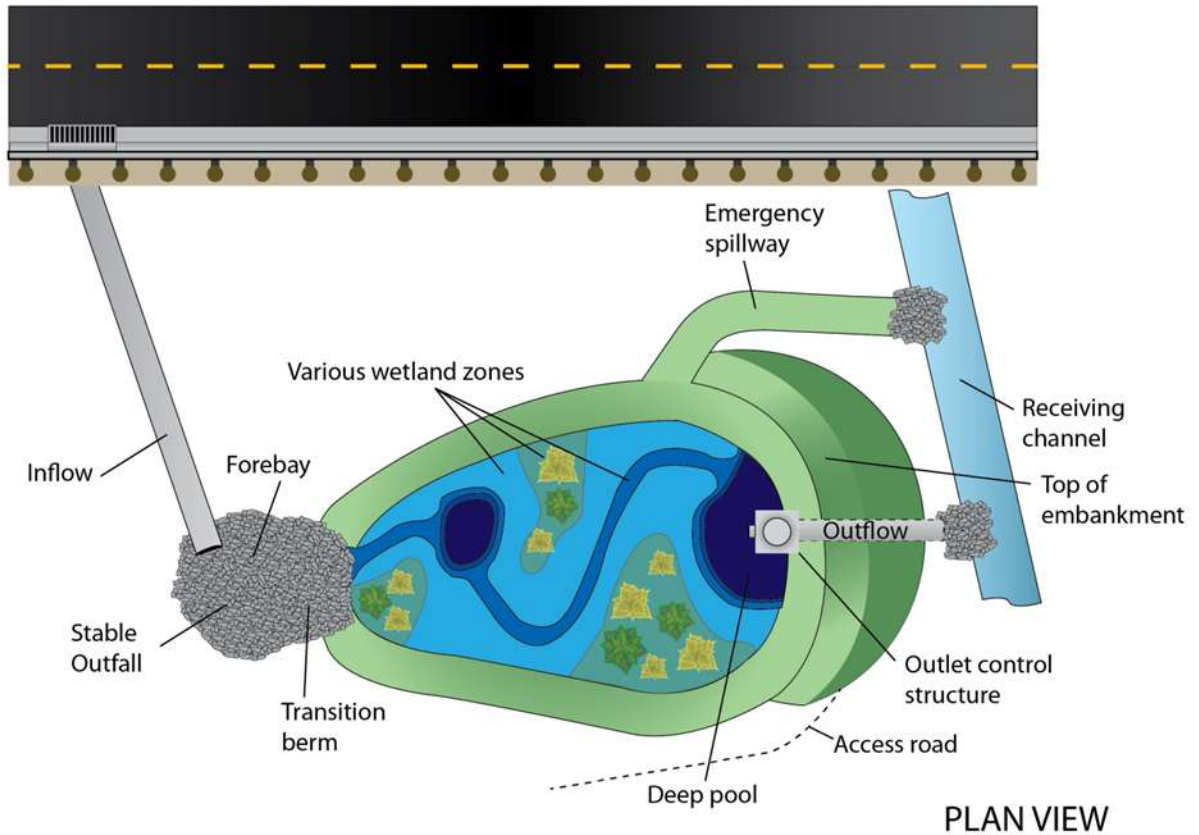

Level 2 stormwater wetlands are intended to meet water quality requirements only; they cannot be used for extended detention. Therefore, the outlet structure design can be simplified. Level 2 wetlands

can be installed parallel to wet detention ponds to meet detention requirements and to help maintain the wetland permanent pool level. Figure 10.6.10-2 illustrates this option.

Figure 10.6.10-2 - Level 2 wetland with wet pond (adapted from CWP, 2008) [\(10-8\)](#)

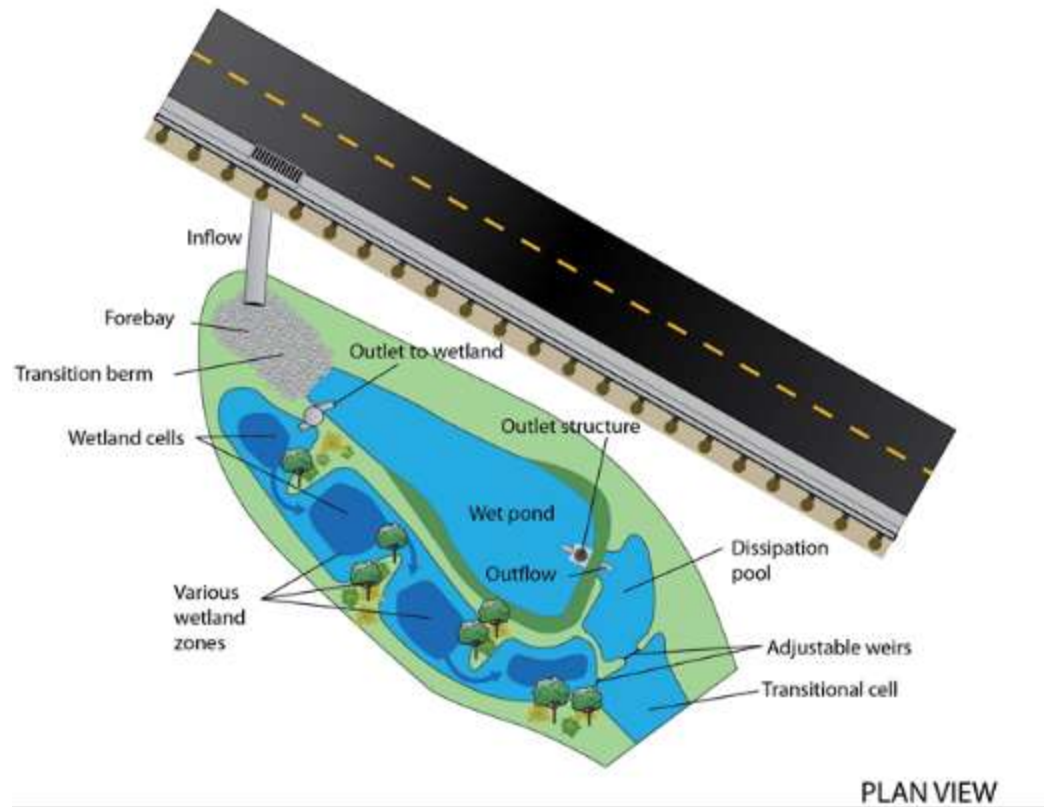

Level 1 wetlands provide sufficient water quality treatment for most sites and have the added flexibility of providing detention. For these reasons, level 1 wetlands will likely be the desired choice for most sites. However, level 2 wetlands may be more applicable where additional water quality treatment is needed due to receiving water impairments or similar issues. Further, level 2 wetlands should be considered where wildlife habitat is of particular concern and in cases where its application will not be considerably more costly than level 1 wetlands.

Stormwater Management Suitability

- **Runoff Reduction** – Stormwater wetlands do not provide runoff reduction credits. Although stormwater wetlands provide moderate to high removal of many of the pollutants of concern typically contained in post-construction stormwater runoff, recent research shows that they provide little, if any, reduction of post-construction stormwater runoff volumes. [\(10-20\)](#)
- **Water Quality** – Pollutants are removed from stormwater runoff in a wetland through uptake by vegetation and algae, filtering, and gravitational settling in the slow-moving marsh flow. Other pollutant removal mechanisms are also at work in a stormwater wetland, including chemical and biological decomposition, and volatilization. A level 1 wetlands provides 80% TSS removal if designed, constructed, and maintained correctly. A level 2 wetlands provides 85% TSS removal if designed, constructed, and maintained correctly.

- Channel Protection – The storage volume above the permanent pool/water surface level in a stormwater wetland is used to provide control of the channel protection volume (CP_v) by releasing the 1-year, 24-hour storm runoff volume over 24 hours (extended detention). It is best to do this with minimum vertical water level fluctuation, as extreme fluctuation may stress vegetation.
- Overbank Flood Protection – A stormwater wetland can also provide storage above the permanent pool/water surface level to reduce the post-development peak flow of the 25-year storm (Q_{p25}) to pre-development levels (detention). If a wetland facility is not used for overbank flood protection, it should be designed as an off-line system to pass higher flows around rather than through the wetland system.
- Extreme Flood Protection – In situations where it is required, stormwater wetlands can also be used to provide detention to control the 100-year, 24-hour storm peak flow (Q_f). Where Q_f peak control is not required, a stormwater wetland must be designed to safely pass extreme storm flows.

Pollutant Removal Capabilities

Level 1 stormwater wetlands provide good treatment and detention but are less cost-effective than wet detention ponds because they require a greater land area. The following average pollutant removal rates for level 1 wetlands may be utilized for design purposes: [\(10-17\)](#)

- TSS – 80%
- TP – 40%
- TN – 30%
- Fecal coliform – 70%
- Heavy metals – 50%

Research shows that level 2 wetland designs achieve the following pollutant removals:

- TSS – 85%
- TP – 75%
- TN – 55%
- Fecal coliform – 85%
- Heavy metals – 60%

Application and Site Suitability

Stormwater wetlands are most applicable in low lying, flat sites with plenty of space, which can limit their application to roadway settings. Further, an adequate supply of runoff or groundwater is necessary to maintain the permanent pool. Figure 10.6.10-3 illustrates typical stormwater wetland components and treatment processes.

Figure 10.6.10-3 - Typical stormwater wetland components and treatment processes

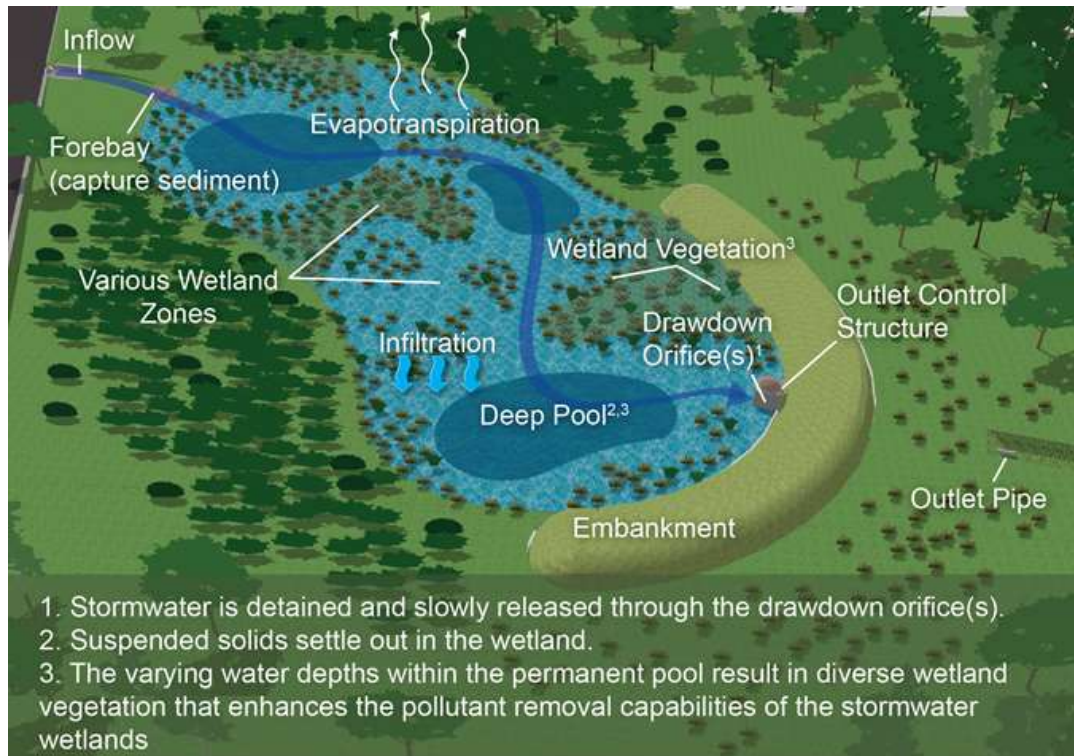

The location of the stormwater wetlands should be determined on a case-by-case basis using sound engineering judgment with consideration for topography, cost, surrounding land use and development, and access. As a general rule, stormwater wetlands should not be located in natural wetland areas or other environmentally-sensitive areas such as live streams. Under special circumstances, post-construction BMPs may be allowed within environmentally sensitive areas with prior consent from appropriate regulatory agencies. For example, if a naturally occurring wetland or other environmentally-sensitive area is impacted, whether it is within an MS4 area or not, post-construction stormwater BMPs may be warranted to protect the impacted area. Siting information and constraints include:

- **Drainage Area** – Minimum drainage area of 5 acres is required to maintain the permanent pool. In some cases, the 5-acre minimum drainage area can be waived.
- **Depth to Water Table** – Stormwater wetlands can be used where the water table is at or near the soil surface, or where there is a sufficient water balance in poorly drained soils to support a wetland plant community. If located above an aquifer or being used to treat a hotspot, however, 2 feet is required between the bottom of a stormwater wetland and the elevation of the seasonally high water table. It is recommended, especially for Level 2 wetlands that the bottom elevation of the wetland intercept the groundwater table. Where stormwater wetlands do not intercept the groundwater table, a liner must be installed on HSG A and B soils. A water balance calculation should be performed to ensure an adequate water budget to support the specified wetland species. A water balance analysis may not be necessary if a liner is installed but should be considered regardless if the drainage area is small and/or has a small amount of impervious area. The stormwater wetland size may need

to be adjusted to account for lost volume due to seasonal fluctuations in the groundwater table.

- **Space Required** – The wetland usually occupies approximately 3-5% of the total drainage area.
- **Minimum Head** – The required elevation difference from the inflow to outflow is typically 2-3 feet.
- **Setbacks** –
 - Property lines – 10 feet (site development projects only)
 - Private wells – 100 feet
 - Septic systems – 50 feet
 - Public-use airports – 5 miles
- **Trout Stream** – Consideration should be given to the thermal influence of stormwater wetland outflows on downstream trout waters.

Challenges associated with roadway configurations include limited right-of-way and clear recovery zone requirements. Stormwater wetlands may be elongated to better fit the linear environment, if necessary. In addition, maintenance must be considered during the design and can often be challenging and hazardous for roadway BMPs. A regenerative stormwater conveyance (RSC) is an emerging linearized BMP that uses wetland concepts to treat stormwater. [\(10-8\)](#) RSCs may be used in special situations with prior coordination and approval from the appropriate GDOT personnel and regulatory agencies. Additional information on RSCs can be found in the Georgia Stormwater Management Manual. [\(10-18\)](#)

Data for Design

The initial data needed for stormwater wetland design includes the following:

- Existing and proposed site, topographic and location maps, and field reviews
- Aerial photographs of the drainage basin to estimate land use areas (grassed, paved, etc.)
- Preliminary plans including plan view, roadway and drainage profiles, cross sections, utility plans, and soil report
- Calculations and details from existing nearby detention facilities
- Water table information

The size and configuration of the stormwater wetland will depend on stormwater management requirements. Level 1 stormwater wetlands are often designed to capture and slowly release the CP_v over 24 hours, maintain the Q_{p25} at existing condition rates, and to adequately control the Q_f . However, one or more of these goals may be waived as described in section 10.4.

After initial data gathering and determination of stormwater management requirements, the designer should proceed with an initial wetland volume estimate. Methods outlined in section 10.7, Detention Design can be used for level 1 designs. The WQ_v method should be used for level 2 designs and for level 1 wetlands that are not designed to meet detention requirements.

If possible, at least two alternating planting peninsulas (or other forms of micro-topography) should extend into the wetland perpendicular to flow. The peninsulas should extend at least 80% of the way across the wetland. This creates a shallow meandering channel that extends the dry weather flow path. It also provides varying permanent pool depths for a diverse wetland ecosystem. Table 10.6.10-1 gives approximate wetland zone criteria that can be used to configure the wetland.

Table 10.6.10-1 Approximate Level 1 and 2 Dimensional Information for Various Wetland Zones			
Wetland Zone	Criteria	Level 1 Design	Level 2 Design
Deep Pools	Depth	-18" to -72"	-18" to -48"
	% of Total Volume	20 %	25%
Low Marsh	Depth	-6" to -18"	N/A
	% of Total Volume	20%	N/A
High Marsh	Depth	-6" to 0"	-6" to +6"
	% of Total Volume	10%	70%
Low Land	Depth	0"+	N/A
	% of Total Volume	50%	N/A

Table 10.6.10-2 Level 1 and 2 Wetland Design Criteria		
Criteria	Level 1	Level 2
WQ _v	As presented in section 10.4.1.2	As presented in section 10.4.1.2
Deep pools	2 (forebay and outlet)	3 (forebay, middle, outlet)
Wetland side slopes (max)	3:1	5:1
Slope profile	8% across the site	Should generally be flat; use multiple cells if needed; max drop of 1' between cells
Normal flow path (distance from inlet to outlet)	1:1	1.5:1
Dry weather flow path	Not required	5:1
Vegetation	Can use solely herbaceous	Include woody vegetation (trees and shrubs)
Average wetland depth	Can be >1	Should be ≤1
Extended detention	Limit to 1' vertically	Not allowed

Micro-topography is an important aspect of level 2 wetland designs. The previously discussed planting peninsulas are often the preferred method. The following methods can be used to enhance micro-topography:

- Snags
- Inverted root wads
- Tree peninsulas
- Coir fiber islands
- Internal pools
- Cobble sand weirs

Consult a stream restoration specialist for additional guidance on these items.

After a rough location and configuration are determined, follow the remaining steps outlined in section 10.7, Detention Design, for sizing and hydrograph routing. Then, integrate the remaining BMP components into the design. Remember that the cumulative flow from multiple detention facilities within the same watershed can negatively impact receiving waters if hydrograph timing is not considered. Perform a hydrologic analysis for the project's zone of influence as described in section 10.2.3 of this chapter. For more information on the design of a stormwater wetland, see the detailed calculation example located at the end of this section.

Pretreatment

Forebays should be provided at wetland inlet areas to capture solids before the stormwater runoff enters the wetland. This will reduce clogging of drawdown orifices, extend the life of the BMP, and facilitate maintenance. Forebays should be sized for 0.1 inches of stormwater runoff per impervious acre and should be 4 to 6 feet deep.

Refer to section 10.8, Common BMP Components, for further guidance.

Vegetation & Landscaping Plan

A vegetation & landscaping plan is an important component of the design of stormwater wetlands. A variety of species should be selected for the various zones of the wetland. Native, non-invasive species are preferred. Aquatic vegetation helps remove pollutants and provides wildlife habitat and aesthetic benefits. Consult a landscaping professional for plant selection. If conditions allow, taller vegetation and trees may be planted around the stormwater wetlands to discourage waterfowl from taking residence in the wetland as they can add to nutrient and bacteria loads. Taller vegetation also provides shade for better thermal control. Woody vegetation, which enhances pollutant removal, infiltration, and evapotranspiration, should be included in level 2 wetlands design. Woody vegetation should not be planted within 15 feet of the embankment or maintenance access areas. [\(10-8\)](#) Refer to GDOT Planting Schedule Special Construction Detail for more information.

Outlet Structure

The configuration of the outlet structure can vary and will depend on stormwater requirements (i.e., WQ_v , CP_v , Q_{p25} , and Q_f). A typical level 1 configuration uses a riser/barrel configuration and emergency spillway to meet all requirements. The level 1 normal pool size can be adjusted so that

the BMP will fit with in the allowable area. The minimum level 1 normal pool size should be 50% of the WQ_v . For larger areas, the normal pool should be equal to the WQ_v .

A deep pool is required at the outlet to prevent clogging and resuspension of sediment. The outlet structure should be designed to allow the water level in the wetland to rise above the permanent pool elevation as runoff (usually the CP_v) is detained, and then slowly draw it down over 24 hours. This 24-hour period may be reduced to 12 hours where runoff temperature is a concern. Additionally, the orifice can be positioned lower to draw off cooler water.

Weirs created towards the top of the riser or the open throat of the riser are typically used to accommodate the Q_{p25} and should be located at an elevation that allows for the storage of the WQ_v plus the CP_v . Outlet protection should be provided downstream of the outlet structure to protect against erosion (refer to chapter 9 of this manual). Maximum release rates from the outlet structure should be targeted towards existing condition rates.

The outlet structure contains a small pipe with a threaded end cap at the lowest elevation of the wetland in the event that the wetland needs to be drained completely. Accessibility to the cap may be difficult at times, depending on the design depth and configuration of the wetland, so it is best that the location of the outlet control structure itself be as close to the embankment as possible to accommodate access. Refer to the GDOT Wet Detention Pond Outlet Structure Special Construction Detail for additional guidance.

Alternatively, a flashboard riser design may be used. Drawdown occurs through orifice holes in the boards located on the front face of the flashboard riser, as shown in Figure 10.6.10-4. These boards can easily be modified or replaced to adjust the water level as needed for maintenance or the health of the wetland vegetation. A baffle can be used to prevent clogging of orifices by floating debris.

Figure 10.6.10-4 - Typical flashboard riser configuration

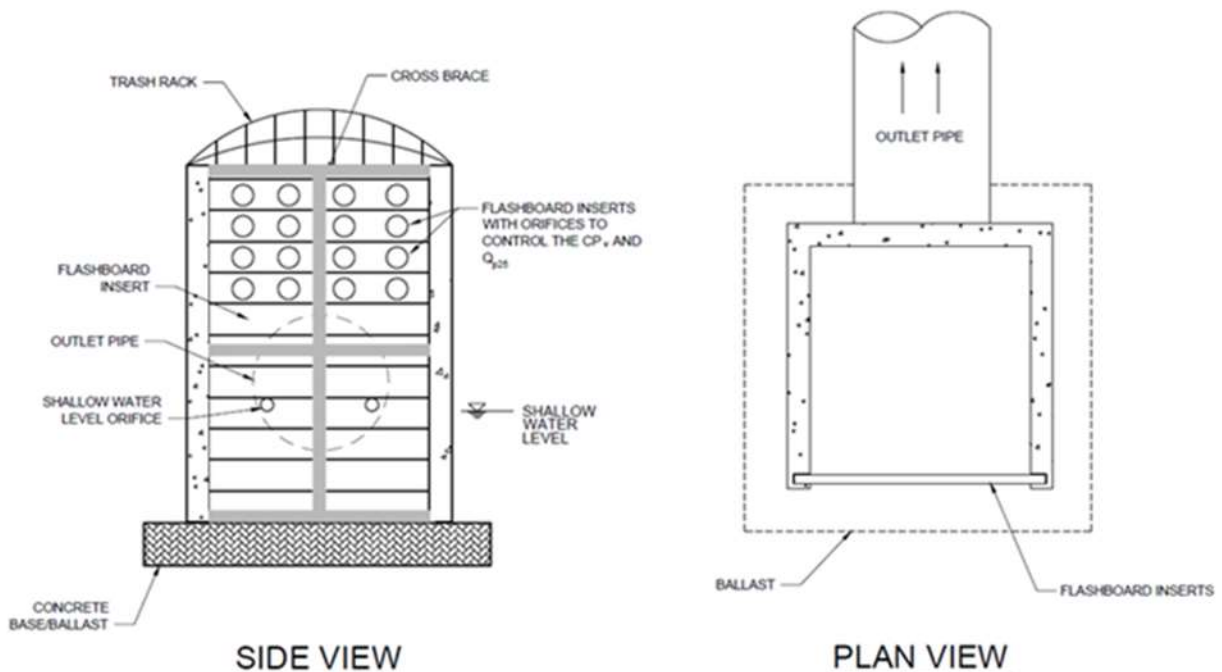

For level 2 designs, the normal pool should encompass the entire WQ_v . The outlet structure may be simplified since detention requirements are not permitted for level 2 designs. For this reason, assume that the water level fluctuation associated with the WQ_v design storm should be limited to 6-8 inches. Similarly, the water level fluctuation associated with the CP_v storm should be limited to 12 inches. This can be accomplished by using a long weir structure capable of conveying large flow rates with little hydraulic head or bypassing larger storm events altogether by using an upstream diversion structure.

The hydrograph routing procedures and weir and orifice equations outlined in section 10.7 of this chapter are used to size the components of the outlet structure. The outlet structure should be designed such that the outflow hydrograph resembles the existing condition hydrograph to the maximum extent practicable.

The buoyancy of the outlet structure should be determined and offset with proper anchoring and/or concrete. Refer to the ACPA document entitled, *Design Data 41 Manhole Flotation* (2008) [\(10-3\)](#) for additional information.

Water Balance

Install an impermeable liner if the stormwater wetland is located on HSG A or B soils and the wetland does not intercept the groundwater table. A water balance analysis should be performed for systems on HSG C and D soils. Refer to section 10.2.4 for water balance calculations. In-situ infiltration testing may be completed if determined to be necessary based on engineering judgement to ensure that the permanent pool will not be completely drawn down.

Emergency Spillway

The emergency spillway is generally an open channel constructed in natural ground (as opposed to the embankment) used to safely pass less frequent storms up to the 100-year event and provides an alternate means of conveying flow should the outlet structure become clogged.

The emergency overflow elevation should be established at the ponding elevation for the 100-year storm event or at least 1 foot below the roadway's normal shoulder break point. Refer to chapter 5 of this manual for channel design guidance. Alternatively, if an earthen emergency spillway channel is not feasible, the riser structure may be sized to accommodate the 100-year storm event.

Embankment

The embankment is a small earthen dam or fill section used to create the downslope side of the wetland. Embankments shall be designed to be less than 25 feet in height and detain less than 100 acre-feet in volume. Embankment height is measured from the elevation of the downstream toe to the maximum water storage elevation. Embankments that exceed these limits should be avoided and are subject to the Georgia Safe Dams Act of 1978. [\(10-13\)](#)

Side slopes of 3:1 or flatter are preferred; however, 2:1 may be acceptable if conditions warrant. Overland flow should be minimized down embankment side slopes. A slope stability analysis is recommended for embankments higher than 10 feet and is required for slopes steeper than 2:1. Appropriate seepage control should be provided according to the size of the embankment and characteristics of the soils and wetland configuration. Refer to the NRCS's Agriculture Handbook 590 [\(10-33\)](#) and geotechnical reports prepared for the project site for additional guidance. Since shallow bedrock beneath the embankment may act as a conduit for seepage through the embankment,

additional seepage prevention measures may be needed in these areas. Finally, the embankment should have 1 foot of freeboard above the 100-year flood elevation with additional consideration for embankment settlement.

Stormwater Wetlands Sizing

1. Determine the goals and primary function of the stormwater wetlands.

The goals and primary function of the BMP must take into account any restrictions or site-specific constraints. Also take into consideration any special surface water or watershed requirements. Determine whether a level 1 or level 2 design is more appropriate.

2. Calculate the Target Water Quality Volume

Calculate the water quality volume formula using the following formula:

$$WQ_v = \frac{1.2 \text{ in} \times (R_v) \times A \times 43560 \frac{\text{ft}^2}{\text{acre}}}{12 \frac{\text{in}}{\text{ft}}}$$

Where:

WQ_v = water quality volume (ft³)

R_v = volumetric runoff coefficient. See section 10.4 for volumetric runoff coefficient calculations.

A = onsite drainage area of the post-condition basin (acres)

3. Determine the pretreatment volume.

A sediment forebay is provided at each inlet, unless the inlet provides less than 10% of the total design storm inflow to the basin. The forebay should be sized to contain 0.1 inch per impervious acre of contributing drainage.

4. Determine the wetlands location and preliminary geometry. Conduct stormwater wetlands grading and determine storage volume available for the permanent pool.

This step involves initially grading the wetlands (establishing contours) and determining the elevation-storage relationship for the wetlands.

5. If applicable, complete a water balance analysis to verify the stormwater wetlands will maintain its permanent pool.

6. Compute extended detention orifice release rate(s) and size(s) and establish CP_v elevation.

The CP_v elevation is determined from the stage-storage relationship and the orifice is then sized to release the difference between the water quality volume and channel protection storage volume over a 24-hour period (12-hour extended detention may be warranted in some cold water stream basins).

7. Calculate the Q_{p25} release rate and water surface elevation.

Set up a stage-storage-discharge relationship for the control structure for the extended detention orifice(s) and the 25-year, 24-hour rainfall event.

8. Design embankment(s) and spillway(s).

To size the emergency spillway, calculate the 100-year, 24-hour storm water surface elevation. Set the top of the embankment elevation at least one foot higher and analyze safe passage of the Extreme Flood Volume (Q_f). At final design, provide safe passage for the 100-year, 24-hour rainfall event.

9. Investigate potential basin hazard classification.

The design and construction of stormwater management ponds are required to follow the latest version of the State of Georgia dam safety rules.

10. Prepare a site vegetation and landscaping plan.

A landscaping plan for stormwater wetlands and its buffer should be prepared to indicate how aquatic and terrestrial areas will be stabilized and established with vegetation. See the GDOT Planting Schedule Special Construction Detail for more information.

Construction Considerations

The following items should be considered during the design and, if warranted, included as notes on the design drawings, in the details or special provisions:

- Place the embankment in shallow lifts under controlled compaction conditions.
- Provide an adequate water-tight seal between the outlet structure and pipes or other appurtenances to avoid leaks and possible failure of the structure.
- Remove sediment from construction activities and establish vegetation before the stormwater wetland is brought online.
- Make holes dug for planting larger to allow for root growth in order to counteract compaction within the wetland, which may limit the growth of newly planted vegetation.

Maintenance Considerations

Without proper maintenance, BMPs will function at a reduced capacity and may cease to function altogether. A properly designed BMP includes the following considerations for maintenance:

- Access:
 - Provide adequate right-of-way.
 - Provide access roads and ramps for appropriate equipment to all applicable components (outlet structure, forebay, etc.).
 - Provide space to turn around if necessary.
 - Check for sufficient area to safely exit and enter the highway, if applicable.
 - If the BMP is fenced, provide appropriately sized gates (refer to section 10.10 for additional guidance regarding fencing and other safety considerations).
 - Adequate access for a small boat may be needed for sediment depth measurements.
- Provide a method for dewatering the wetland.

Refer to GDOT's *Stormwater System Inspection and Maintenance Manual*, for specific maintenance requirements.

Stormwater Wetland Example Calculation

GIVEN:

- A new roadway project located in Savannah, GA.
- The proposed project includes 3,000 feet of roadway (in length).
- The drainage area that discharges to the stormwater wetland includes the following: two 12-foot lanes, two 6-foot paved shoulders, and two 20-foot wide grassed areas (on either side of the road), draining via sheet flow.
- Offsite stormwater also provides supplemental runoff to maintain the permanent pool (assume 2 acres for the purposes of this example).
- A level 2 stormwater wetland is desired to provide additional water quality benefits and wildlife habitat.
- Wetland dimensions were simplified and assumed for the purposes of this example.
- The designer has previously calculated the following hydrologic information:
 - Permanent pool = $WQ_v = 10,936 \text{ ft}^3$

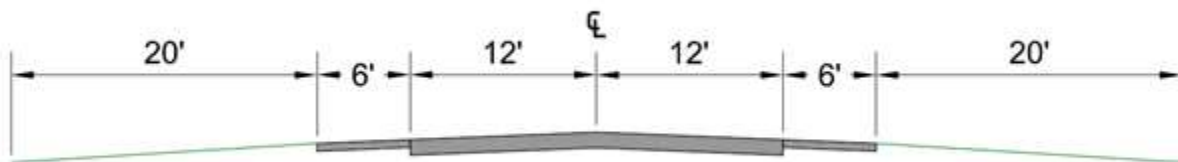

FIND:

- Size the stormwater wetland permanent pool, individual wetland zones, and outlet structure to treat the WQ_v .
- Perform a water balance calculation to verify that the permanent pool will be maintained to an acceptable degree.
- Note that a separate hydrograph routing example calculation is given in section 10.7 to illustrate the calculations associated with the Q_{p25} and Q_f .
- Note that extended detention should not be used in level 2 stormwater wetlands.

SOLUTION:

1. The target water quality volume was already calculated to be $10,936 \text{ ft}^3$ which will be the volume of the permanent pool.
2. For level 2 wetlands, the following wetland zones should be provided:

Wetland Zone	Depth (relative to permanent pool)	% of Total Volume
Deep Pools	-18" to -48"	25%
High Marsh	-6" to +6"	70%

Note that these are approximate guidelines. The 5% that is unaccounted for is the result of short transition zones from high marsh to deep pools.

At least three deep pools should be provided. One of which is the forebay.

$$Total\ deep\ pool\ volume = 25\% \times 10,936\ ft^3 = 2,734\ ft^3$$

$$Forebay\ volume = 0.1\ inches \times Impervious\ Acreage$$

$$Forebay\ volume = 0.1\ in \times \frac{36\ ft \times 3,000\ ft}{43,560\ \frac{ft^2}{ac} \times 12\ \frac{in}{ft}} = 0.021\ ac - ft = 915\ ft^3$$

Remaining pools (assume two):

$$\frac{2,734 - 915}{2} = 910\ ft^3$$

$$Total\ deep\ pool\ volume = 75\% \times 10,936\ ft^3 = 8,202\ ft^3$$

3. A water balance calculation should be performed to verify that there is adequate runoff supply to maintain the permanent pool. Refer to the wet detention pond example calculation in section 10.6.9.
4. A simple weir outlet structure will be used for this example. Extended detention is not permitted for level 2 wetlands. For this reason, assume the water level rise associated with the WQ_v design storm should be limited to 8 inches and the CP_v storm should be limited to 12 inches. Use this information and the guidance in section 10.7 to design the outlet structure.

Additional Considerations:

The wetland must be positioned within the available footprint and designed to fit the site’s topography. Incorporate the various zones and configure the planting peninsulas into the site plan. A qualified professional should develop a planting plan that utilizes various woody species.

A stage-storage relationship that reflects the wetland’s side slopes and any irregular topography should be established to more accurately represent storage volumes associated with various water surface elevations. Note that the wetland should be designed to convey the 100-yr storm for the total drainage area (including offsite runoff) without failure unless it is designed to be offline.

Summary

10.6.11 Open-Graded Friction Course



Advantages	Disadvantages
<ul style="list-style-type: none"> • Offers increased safety benefits on wet roadway conditions • Can be applied to more area per ton than conventional asphalt pavement • Can be cost effective • Removes TSS 	<ul style="list-style-type: none"> • Drainage can be impeded by sediment deposition • Improper installation leads to rapid deformation

Description: Open-graded friction course (OGFC) is a thin, permeable layer of asphalt that encompasses a support structure consisting of a uniform, coarse aggregate size with minimal fines, and serves as an overlay to conventional asphalt pavements. OGFC has a high void content that creates permeability allowing for the infiltration of stormwater runoff.

Design Considerations:

- Leveling of existing asphalt overlay required prior to installation of OGFC overlay
- Porous nature requires installation during optimal temperatures as specified in standard specifications
- Requires coordination with other offices and project team members

Maintenance Considerations:

- Drainage and lateral flow should not be impeded by compaction

Applicability for Roadway Projects:

- Highly suitable for roadway pavement and resurfacing projects with higher annual average daily traffic volumes and may be used in conjunction with additional stormwater BMPs if adequate right-of-way is available

Stormwater Management Suitability:

- Runoff Reduction
- Water Quality
- Channel Protection
- Overbank Flood Protection
- Extreme Flood Protection

Suitable for this practice May provide partial benefits Not suitable

LID/GI Considerations

Since OGFC offers water quality treatment through stormwater filtration, it can be considered an LID/GI control when used for this purpose. OGFC is an effective form of pretreatment when used in combination with filter strips and other types of structural storm water BMPs.

Treatment Capabilities



10.6.11 Open-Graded Friction Course

Description

Open-graded friction course (OGFC) is a thin, permeable layer of asphalt that encompasses a support structure consisting of a uniform, coarse aggregate size with minimal fines, and serves as an overlay to conventional asphalt pavements. OGFC has traditionally been used to reduce vehicle spray, absorb noise from vehicle traffic, and also has an increased resistance to surface friction. The permeability of OGFC allows for water to enter and flow through the aggregate matrix, and not directly off the pavement surface. As a result, OGFC not only increases the safety of motorists by decreasing splash and spray, reduces the potential for hydroplaning, and improves the visibility of pavement markings, but it also serves as a benefit to the environment by providing a reduction in TSS. The large number of void spaces within the structure of OGFC provides a stormwater detaining effect, a proven reduction of TSS within stormwater runoff, and a minimization of sediment impacts. This applies to all GDOT types of OGFC including conventional, modified, and porous European mix (PEM). Figure 10.6.11-1 illustrates the typical design structure of OGFC.

Figure 10.6.11-1 - OGFC (left) and conventional asphalt (right) cross sections

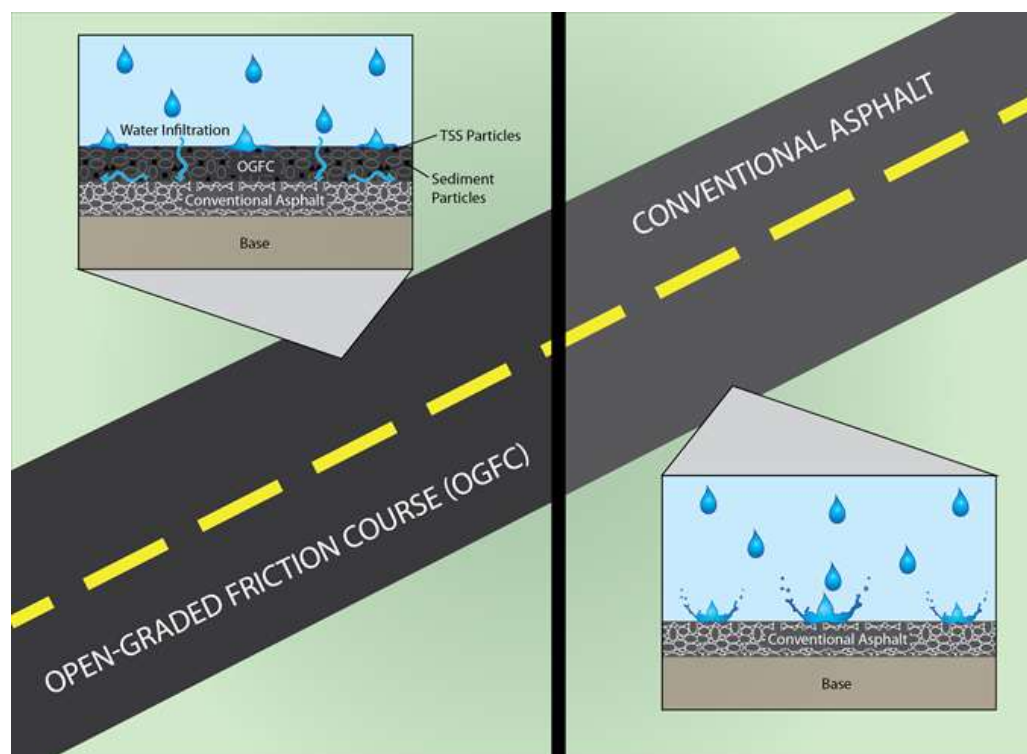

Stormwater Management Suitability

- Runoff Reduction – OGFC does not provide runoff reduction credits.
- Water Quality – The large number of void spaces within the structure of OGFC provides a stormwater detaining effect, a proven reduction of TSS within stormwater runoff, and a minimization of sediment impacts. When sized correctly, OGFC provides a 80% TSS removal efficiency.
- Channel Protection – Another practice must be used to provide CP_v extended detention.
- Overbank Flood Protection – Another control will be required in conjunction with OGFC to reduce the post-development peak flow of the 25-year storm (Q_{p25}) to pre-development levels (detention).
- Extreme Flood Protection – Another practice must be used to provide extreme flood protection.

Pollutant Removal Capabilities

Research has shown that the use of OGFC results in a delayed runoff rate, minimization of sediment impacts due to the reduction of wash off from the undercarriage of vehicles, and a removal of TSS concentrations. If properly maintained, water quality benefits can last throughout the design life of the pavement.

Similar transportation related research sponsored by the Federal Highway Administration and Texas Department of Transportation can also be referenced. These studies consistently reported TSS removal rates of 90-91%.^(10-4, 10-5) Thus, a conservative TSS pollutant removal rate of 80% may be utilized for water quality design purposes.

Application and Site Suitability

In relation to post-construction stormwater benefits, OGFC is most applicable for roadway segments that span areas adjacent to and across sensitive water bodies. Research has shown that resurfacing of these roadway segments with an OGFC overlay can provide the same functionality as other structural BMPs, such as TSS removal. Roadside filter strips combined with OGFC offer additional water quality benefits on highways without curb and gutter systems. Refer to section 10.4.1 for additional information regarding filter strips.

OGFC is commonly applied to roadway projects and resurfacing routes with a high volume of annual average daily traffic (AADT). Therefore, OGFC can be a cost-effective BMP, particularly for projects requiring resurfacing (i.e., widening and bridge replacement projects). OGFC may also prove to be feasible along rural and low traffic roadways. An alternative to OGFC may be necessary when considering the design for areas with severe turning movements such as parking lots. Collaboration may be required between the design engineer, structural engineer, and material divisions within GDOT to coordinate the practicalities of OGFC in its desired location. This may be the case for potential use on bridge approaches and decks, as an example.

Design

The OGFC mix and specifications are typically determined by the Office of Materials and Research. Designers shall coordinate with the Office of Materials and Research to verify acceptable locations

for OGFC and to make all members of the project team aware that OGFC is part of the post-construction stormwater management plan. OGFC shall only be used when recommended by the Office of Materials and Testing based on the Criteria for Use of Asphaltic Concrete and Mix Types. A uniform cross-section must be maintained to ensure lateral drainage toward the road shoulder. Changes to the pavement design may result in the need for additional BMPs.

Additional Design Considerations

OGFC has some limitations when compared to conventional pavements. These include an increased potential for stripping, raveling, and shoving which result in decreased structural value of the pavement. Special snow and ice control methods and rehabilitation techniques that allow for proper drainage through the OGFC overlay are also required.

Construction Considerations

It is important to adhere to Section 400 within the *Georgia Department of Transportation's Standard Specifications Construction of Transportation Systems, 2013 Edition* during construction as there are many practices to consider while installing the OGFC. The OGFC layer should be installed during optimal temperatures. Cold temperatures tend to inhibit the bond between the OGFC and existing pavement, and installation during windy conditions may cool the mixture too rapidly. Special care should be taken not to impede the drainage of the OGFC. Improper practices during construction activities that allow mud and sand to enter the pavement area can make the porous nature of the OGFC overlay vulnerable to clogging. Clogging of the voids within the OGFC reduces its drainage capacity and should be avoided. It is important that erosion and sediment control devices associated with construction projects remain in place until all areas are permanently stabilized with vegetation.

Maintenance Considerations

Note that for areas where OGFC is used to meet post-construction stormwater management requirements, it is likely not acceptable to resurface with conventional asphalt without implementing additional BMPs.

Maintenance of the OGFC is largely dependent upon the AADT. As with any stormwater BMP, OGFC will not function properly if it lacks appropriate maintenance. Shear failures, cracking, raveling, delamination, and the clogging of voids within its porous structure are conditions that warrant maintenance. The sealing of cracks and installation of patches can create areas that retain water over time, which may eventually contribute to additional problems. If the OGFC overlay requires patching, it should be repaired with OGFC. Periodic maintenance may be required to remove sediment buildup on the roadway shoulders caused by low traffic volumes in these areas. The lateral flow of water through the OGFC overlay must be maintained to sustain its functionality.

Refer to GDOT's *Stormwater System Inspection and Maintenance Manual*, for specific maintenance requirements.

10.7 Detention Design

Overview

Detention sizing and design require employing the following steps:

- Estimating storage volume

- Estimating peak flow reduction
- Defining the stage-storage relationship
- Defining the stage-discharge relationship (performance curve) including:
 - Outlet design
 - Emergency spillway design
 - Conducting hydrograph routing

Estimating Storage Volume

In order to establish the size of the storage basin, a preliminary estimate of the needed storage capacity and the shape of the storage facility are required. This is an iterative process, requiring multiple trials to ensure the necessary peak reduction and desired outflow hydrograph are achieved. The number of trials necessary can be reduced by ensuring accurate computations in the early stages of this process.

The following sections present four methods for determining an initial estimate of the storage required to provide a specific reduction in peak discharge, including the hydrograph method, triangular hydrograph method, NRCS procedure, and regression equation. Once the initial estimate is established, routing is required to finalize the design based on storage volume and outlet structure configuration.

Hydrograph Method

For storage calculations using the hydrograph method, the inflow hydrograph and desired release rate must be determined. The inflow hydrograph represents the runoff from the watershed flowing into the detention basin. The outflow hydrograph is unknown and will be established based on flow attenuation provided by the storage facility. However, for the initial estimation of the needed storage, the outflow hydrograph must be estimated by approximating by straight lines or sketching an assumed outflow curve as shown on Figure 10.7-1. The peak of this estimated outflow hydrograph must not exceed the desired peak outflow from the detention basin. With these values established, the detention basin discharge curve can be estimated and sketched. The shaded area between the curves represents the estimated required storage. To determine the necessary storage, the shaded area can be planimeted or computed mathematically by using a reasonable time period.

Figure 10.7-1 - Hydrograph method for estimating required storage (10-7)

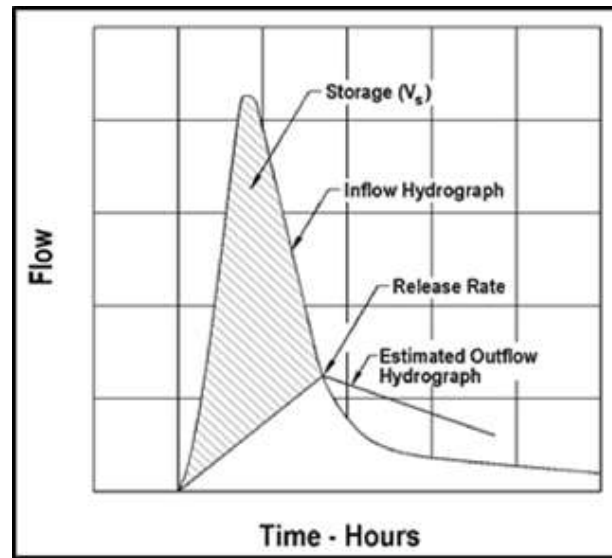

Triangular Hydrograph Method

In the triangular hydrograph method, a preliminary estimate of the storage volume (V_s) required for peak flow attenuation may be obtained from a simplified design procedure that replaces the actual inflow and outflow hydrographs with standard triangular shapes. This method should not be applied if the hydrographs cannot be approximated by a triangular shape; doing so would introduce additional errors to the preliminary estimate of the required storage. This procedure is illustrated by Figure 10.7-2. The required V_s may be estimated from the area above the outflow hydrograph and inside the inflow hydrograph as defined by Equation 10.7-1. (10-7)

$$V_s = 0.5t_b(Q_i - Q_o) \quad (10.7-1)$$

Where:

V_s = Storage volume estimate (ft^3)

Q_i = Peak proposed inflow rate into the basin (ft^3/s)

Q_o = Peak existing condition outflow rate out of the basin (ft^3/s)

t_b = Duration of basin inflow(s)

Figure 10.7-2 - SCS detention basin routing curves [\(10-7\)](#)

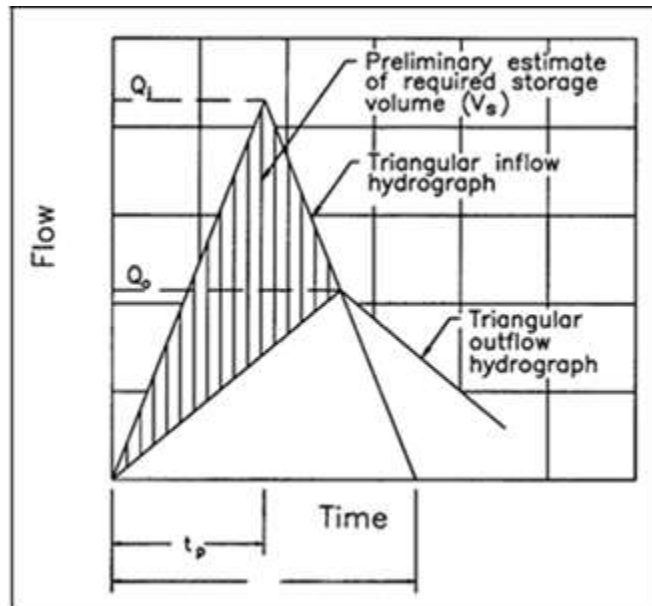

The duration of basin inflow should be derived from the estimated inflow hydrograph. The triangular hydrograph procedure was found to compare favorably with more complete design procedures involving reservoir routing. Refer to the FHWA's HEC No. 22 [\(10-7\)](#) for additional information regarding the triangular hydrograph method.

NRCS TR55 Method

The NRCS, in its TR-55 Second Edition Report [\(10-34\)](#), describes a manual method for estimating required storage volumes based on peak inflow and outflow rates (www.wcc.nrcs.usda.gov/hydro/hydro-tools-models-tr55.html). The TR55 method is based on average storage and routing effects observed for a large number of structures. A dimensionless figure relating the ratio of V_s to the inflow runoff volume (V_r) with the ratio of Q_o to Q_i was developed, as illustrated in Figure 10.7-3. This procedure for estimating V_s may have errors up to 25 percent of the actual volume and, therefore, should only be used for preliminary estimates.

The procedure for estimating the detention storage required is described as follows:

1. Determine Q_i and Q_o (using the NRCS TR-55 method)
2. Compute the ratio Q_o / Q_i
3. Compute V_r , for the design storm

Figure 10.7-3 - SCS detention basin routing curves (10-7)

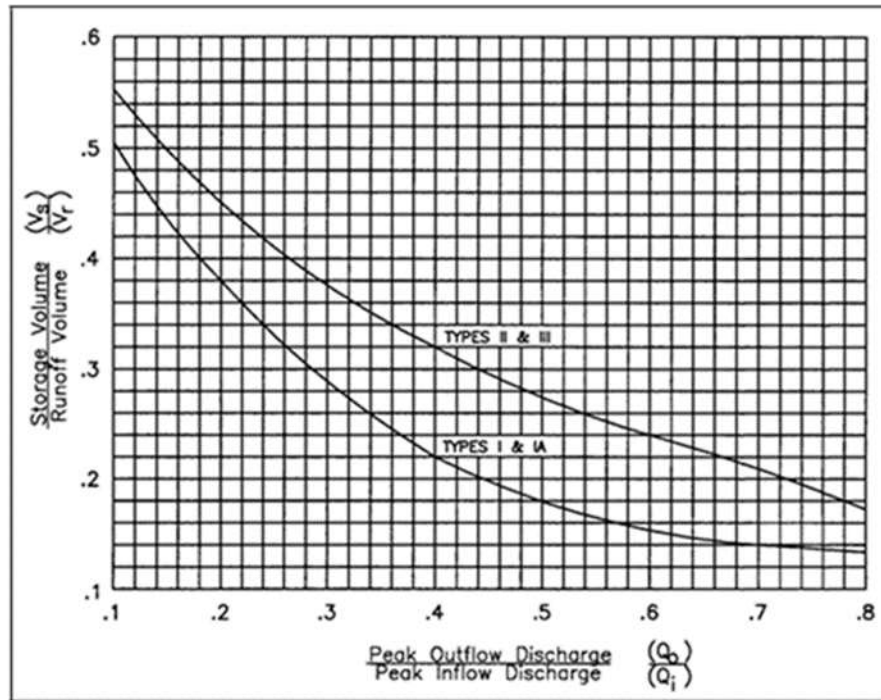

$$V_r = K_r Q_D A_m \tag{10.7-2}$$

Where:

- V_r = Inflow volume of runoff (ac-ft)
- K_r = 53.33 (dimensionless)
- Q_D = Depth of runoff (in)
- A_m = Area of watershed (mi²)

4. Using Figure 10.7-3, determine the ratio V_s/V_r .
5. Determine V_s as

$$V_s = V_r \left(\frac{V_s}{V_r} \right) \tag{10.7-3}$$

Regression Equation Method

An estimate of V_s required for a specified peak flow reduction can be obtained by using the following regression equation method first presented by Wycoff & Singh. (10-42)

1. Determine the V_r in the inflow hydrograph, Q_o , t_b , and the time to peak of the inflow hydrograph (t_p).
2. Calculate a preliminary estimate of the ratio V_s/V_r using the input data from step 1 and the following equation:

$$\left(\frac{V_s}{V_r}\right) = 1.291 \frac{\left(1 - \frac{Q_o}{Q_i}\right)^{0.753}}{\left(\frac{t_b}{t_p}\right)^{0.411}} \quad (10.7-4)$$

3. Multiply V_r times the volume ratio computed from Equation 10.7-4 to obtain an estimate of the required V_s .

Estimating Peak Flow Reduction

Similarly, if V_s is known and the designer wants to estimate the peak discharge, two methods can be used. First, the TR-55 method as demonstrated in Figure 10.7-3 can be solved backwards for the ratio of Q_o/Q_i . Secondly, a preliminary estimate of the potential peak flow reduction can be obtained by rewriting the regression Equation 10.7-4 in terms of discharges. This use of the regression equations is demonstrated below.

1. Determine V_r , Q_i , t_b , t_p , and V_s .
2. Calculate a preliminary estimate of the potential peak flow reduction for the selected storage volume using the following equation.

$$\left(\frac{Q_o}{Q_i}\right) = 1 - 0.712 \left(\frac{V_s}{V_r}\right)^{1.328} \left(\frac{t_b}{t_p}\right)^{0.546} \quad (10.7-5)$$

3. Multiply Q_i times the potential peak flow reduction ratio calculated from step 2 to obtain Q_o for the selected V_s .

Stage-Storage Relationship

A stage-storage relationship defines the relationship between the depth of water and V_s in the storage facility. The volume of storage can be calculated by using simple geometric formulas expressed as a function of storage depth. This relationship between V_s and depth defines the stage-storage curve. A typical stage-storage curve is illustrated in Figure 10.7-4.

Figure 10.7-4 - Example stage-storage curve [\(10-7\)](#)

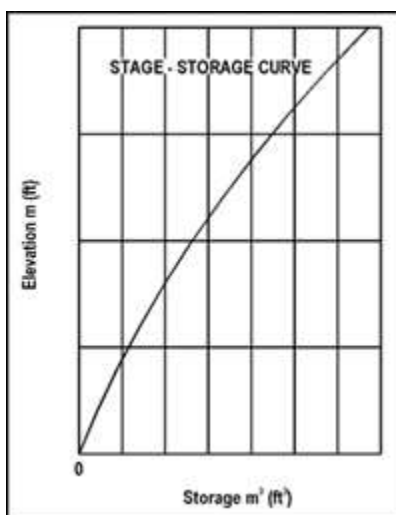

After the required storage has been estimated, the configuration of the storage basin must be determined so that the stage-storage curve can be developed. Detention facilities can take various shapes including:

- Rectangular
- Trapezoidal
- Pipes and conduits
- Natural basins

Stage-storage calculations vary depending on the shape of the facility. Refer to HEC 22 [\(10-7\)](#) for additional information. Additionally, popular software packages, such as HydroCAD and Bentley PondPack and InRoads, are capable of generating stage-storage data.

Stage-Discharge Relationship (Performance Curve)

A stage-discharge (performance) curve defines the relationship between the depth of water and the discharge or outflow from a storage facility. A typical storage facility will have both a principal and an emergency outlet. The principal outlet is typically designed to convey the design storms below the 100-year recurrence interval. The 100-year, 24-hour storm can be designed to safely pass via the emergency spillway. The principal outlet structure typically consists of a pipe culvert, weir, orifice, or other appropriate hydraulic control device. Multiple outlet control devices are often used to provide discharge controls for multiple frequency storms (i.e., CP_v , Q_{p25} , and Q_f).

Development of a composite stage-discharge curve requires consideration of the discharge rating relationships for each component of the outlet structure. The following sections present design relationships for typical outlet controls.

Orifices and Weirs

Orifice flow can be determined using the orifice equation described in chapter 4 of this manual. Values for C_D typically range from 0.6 for square-edged, uniform orifice entrance conditions to 0.4 for ragged edged orifices (e.g., holes cut in corrugated pipe using a torch).

Outlet pipes smaller than 1 foot in diameter may be analyzed as a submerged orifice as long as the change in head (H) divided the diameter of the orifice (D) is greater than 1.5. Pipes greater than 1 foot in diameter should be analyzed as a discharge pipe with headwater and tailwater effects taken into account.

Flow through multiple orifices can be computed by summing the flow through individual orifices. For multiple orifices of the same size and under the influence of the same effective head, the total flow can be determined by multiplying the discharge for a single orifice by the number of openings.

The weir equation is also described in chapter 4. Values for C_D range from 3.33 for sharp-crested weirs, to 2.34–3.32 for broad-crested weirs. Weir calculations are commonly needed for discharge locations through the sides of risers, through the tops of risers, and over emergency spillways.

Additional guidance for weir and orifice flow can be found in HEC 22. [\(10-7\)](#)

Discharge Pipes

Discharge pipes are often used as outlet structures for detention facilities and can be designed for single- or multi-stage discharges. A single-stage discharge system consists of a single culvert entrance designed to carry emergency flows according to design procedures outlined in Hydraulic Design of Highway Culverts. [\(10-32\)](#) A multi-stage inlet includes a control structure at the inlet end of the pipe (referred to as the outlet structure) that is designed so that design flows discharge through a weir or orifice in the lower levels of the structure and emergency flows pass over the top of the structure. The outlet pipe should have capacity to carry the full range of flows from a drainage area including the emergency flows.

Design of multi-stage structures begins with determination of peak discharges that must be passed through the facility. Second, the designer should select a pipe with the capacity to pass the peak flow within the allowable headwater and develop a performance curve for the pipe. Third, the designer should develop a stage-discharge curve for the outlet control structure incorporating the discharge pipe headwater as the tailwater condition for the outlet structure. Lastly, the designer should perform basin routing using the stage-discharge curve.

Emergency Spillway

The purpose of an emergency spillway is to provide a controlled overflow relief for storm flows in excess of the design discharge for the storage facility. Detention storage facilities for highway applications often use a broad-crested overflow weir cut through the original ground next to the embankment for overflow passage, as illustrated in Figure 10.7-5. The transverse cross-section of the weir cut is typically trapezoidal in shape for ease of construction. The emergency overflow elevation shall be established at least one (1) foot below the roadway's normal shoulder break point and at an elevation that will not inundate the roadway base.

Figure 10.7-5 - Discharge coefficients for emergency spillways [\(10-7\)](#)

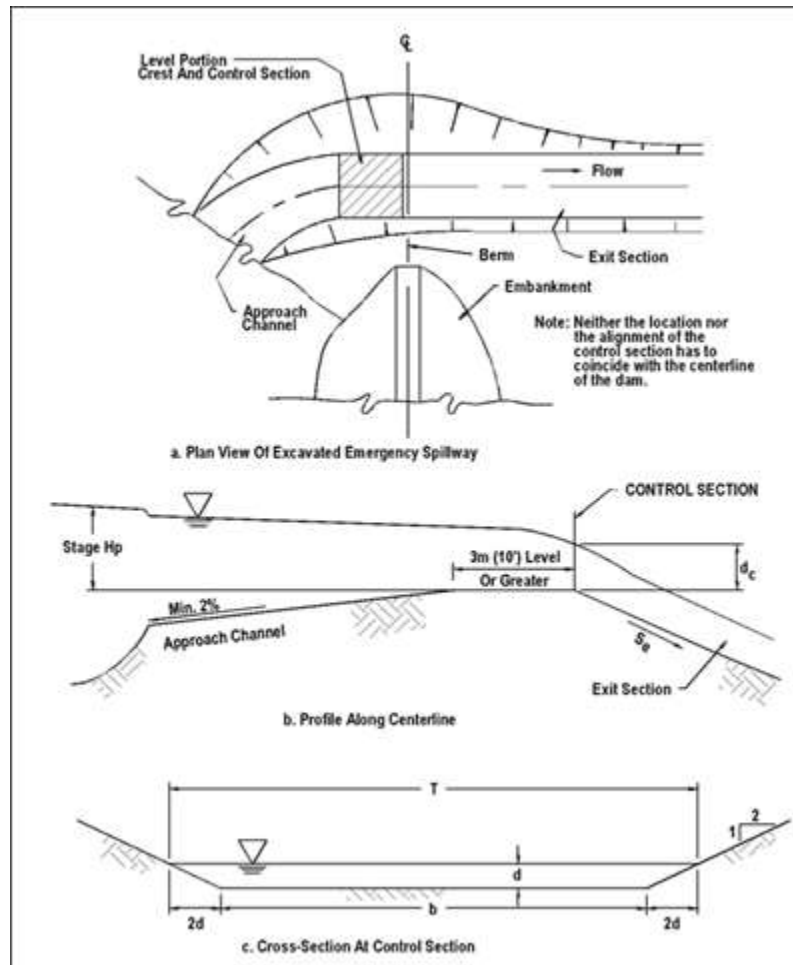

The weir equation presented in chapter 4 may be used to calculate flow through the emergency spillway at various stages. C_D varies based on spillway bottom width (L) and head (H). Figure 10.7-6 can be used to determine C_D for emergency spillway flow for grassed channels with a Manning's n of 0.040. Equations presented in HEC 22 [\(10-7\)](#) can be used for different configurations. The top of the spillway section and channel extending down the slope should be protected with a temporary Type 1 Turf Reinforcement Matting (TRM1).

Figure 10.7-6 - Discharge coefficients for emergency spillways [\(10-7\)](#)

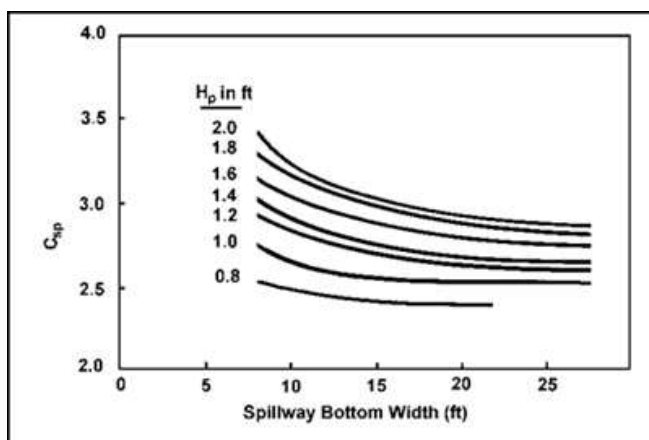

Composite Stage Discharge Curves

As indicated by the discussions in this section, development of a stage-discharge curve for a particular outlet control structure depends on the interaction between each component of the control structure. Figure 10.7-7 illustrates the construction of a stage-discharge curve for an outlet control device consisting of a low flow orifice and a riser pipe connected to an outflow pipe. The structure also includes an emergency spillway.

The impact of each element in the control structure can be seen in Figure 10.7-7. Initially, the low flow orifice controls the discharge. At an elevation of 35.4 feet, the water in the storage facility reaches the top of the riser pipe and begins to flow into the riser. The flow at this point is a combination of the flows through the orifice and the riser. Orifice flow through the riser controls the riser discharge above a stage of 36.1 feet. At an elevation of 38.0 feet, flow begins to pass over the emergency spillway. Beyond this point, the total discharge from the facility is a summation of the flows through the low flow orifice, the riser pipe, and the emergency spillway. Additionally, the designer needs to verify that the outlet pipe from the detention basin is large enough to carry the total flows from the low flow orifice and the riser section to prevent the outlet pipe from controlling the flow from the basin.

Figure 10.7-7 - Typical combined stage-discharge relationship (10-7)

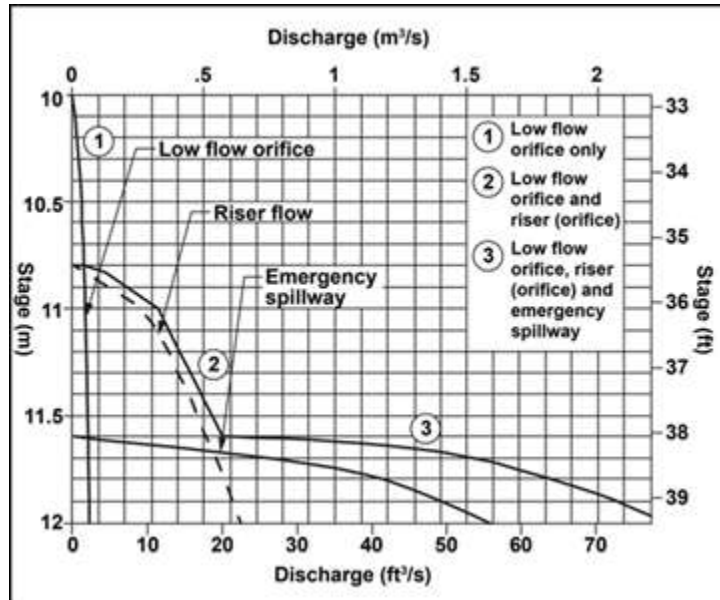

Generalized Routing Procedure

Various software packages can be used to assist in completing the detention basin design steps and routing. The example calculation provided at the end of this section describes the general approach for using software to assist in detention design. The manual routing procedure will be briefly described to give designers a basic understanding of the underlying principles. Additional guidance and example calculations can be found in HEC 22 (10-7). The most commonly used method for routing an inflow hydrograph through a detention pond is the Storage Indication or Modified Puls method. This method begins with the continuity equation, which states that the inflow minus the outflow equals the change in storage ($I - O = DS$). By taking the average of two closely spaced inflows and two closely spaced outflows, the method is expressed by Equation 10.7-6. This relationship is illustrated graphically in Figure 10.7-8.

Figure 10.7-8 - Schematic of routing hydrograph (10-7)

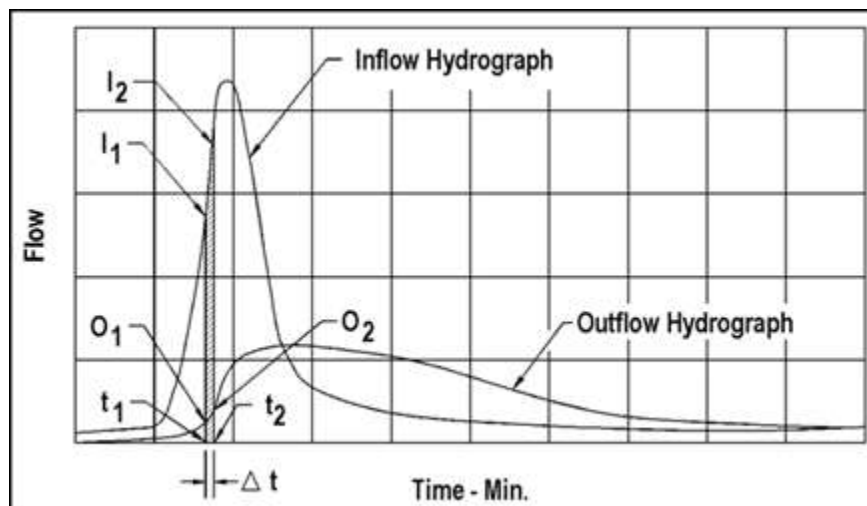

$$\frac{\Delta S}{\Delta t} = \frac{I_1 + I_2}{2} - \frac{O_1 + O_2}{2} \tag{10.7-6}$$

Where:

ΔS = Change in storage, ft³

t = Time interval, min

I = Inflow, ft³

O = Outflow, ft³

Equation 10.7-6 can be rearranged as shown in Equation 10.7-7. The following procedure can be used to perform routing through a reservoir or storage facility using Equation 10.7-7.

$$\frac{I_1 + I_2}{2} + \left(\frac{S_1}{\Delta t} + \frac{O_1}{2} \right) - O_1 = \left(\frac{S_2}{\Delta t} + \frac{O_2}{2} \right) \tag{10.7-7}$$

- Step 1. Develop an inflow hydrograph, stage-discharge curve, and stage-storage curve for the proposed storage facility.**
- Step 2. Select a routing time period, Dt, to provide a minimum of five points on the rising limb of the inflow hydrograph.**
- Step 3. Use the stage-storage and stage-discharge data from step 1 to develop a storage indicator numbers table that provides storage indicator values, S/Dt + O/2, versus stage. A typical storage indicator numbers table contains the following column headings:**

(1)	(2)	(3)	(4)	(5)	(6)
Stage	Discharge (O)	Storage (S)	O ₂ /2	S ₂ /Dt	S ₂ /Dt+ O ₂ /2
ft	ft ³ /s	ft ³	ft ³ /s	ft ³ /s	

- a. The O and S are obtained from the stage-discharge and stage-storage curves, respectively.
- b. The subscript 2 is arbitrarily assigned at this time.
- c. The time interval (Dt) must be the same as the Dt used in the tabulated inflow hydrograph.

Step 4. Develop a storage indicator numbers curve by plotting the outflow (column 2) vertically against the storage indicator numbers in column (6). An equal value line plotted as O₂ = S₂/Dt + O₂/2 should also be plotted. If the storage indicator curve crosses the equal value line, a smaller time increment (Dt) is needed (refer to Figure 10.7-9).

Figure 10.7-9 - Storage indicator curve [\(10-7\)](#)

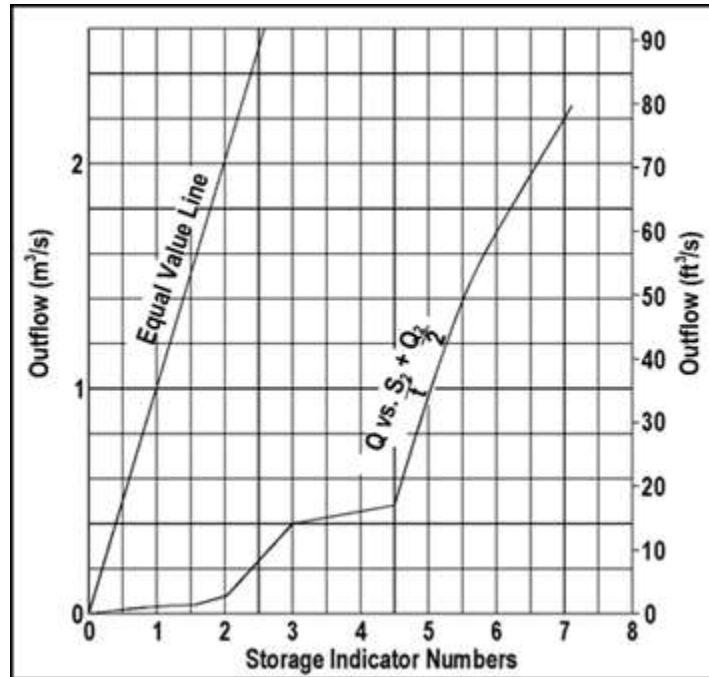

Step 5. A supplementary curve of storage (column 3) vs. $S_2/Dt + O_2/2$ (column 4) can also be constructed. This curve does not enter into the mainstream of the routing; however, it is useful for identifying storage for any given value of $S_2/Dt + O_2/2$. A plot of storage vs. time can be developed from this curve.

Step 6. The routing can now be performed by developing a routing table for the solution of Equation 10.7-7 as follows:

(1)	(2)	(3)	(4)	(5)	(6)	(7)
Time	Inflow	$(I_1+I_2)/2$	$S_1/t+O_1/2$	O_1	$S_2/t+O_2/2$	O_2
(hr)	(ft ³ /s)	(ft ³ /s)	(ft ³ /s)	(ft ³ /s)	(ft ³ /s)	(ft ³ /s)

- Columns (1) and (2) are obtained from the inflow hydrograph.
- Column (3) is the average inflow over the time interval.
- The initial values for columns (4) and (5) are generally assumed to be zero since there is no storage or discharge at the beginning of the hydrograph when there is no inflow into the basin.
- The left side of Equation 10.7-7 is determined algebraically as columns (3) + (4) - (5). This value equals the right side of Equation 10.7-7 or $S_2/Dt + O_2/2$ and is placed in column (6).
- Enter the storage indicator curve with $S_2/Dt + O_2/2$ (column 6) to obtain O_2 (column 7).
- Column (6) ($S_2/Dt + O_2/2$) and column (7) (O_2) are transported to the next line and become $S_1/Dt + O_1/2$ and O_1 in columns (4) and (5), respectively. Because ($S_2/Dt + O_2/2$) and O_2 are the ending values for the first-time step, they can also be said to be the beginning values for the second time step.

- g. Columns (3), (4), and (5) are again combined and the process is continued until the storm is routed.
- h. Peak storage depth and discharge (O_2 in column (7)) will occur when column (6) reaches a maximum. The storage indicator numbers table developed in Step 3 is entered with the maximum value of $S_2/Dt + O_2/2$ to obtain the maximum amount of storage required. This table can also be used to determine the corresponding elevation of the depth of stored water.
- i. The designer needs to make sure that the peak value in column (7) does not exceed the allowable discharge as prescribed by the stormwater management criteria.

Step 7. Plot O_2 (column (7)) versus time (column (1)) to obtain the outflow hydrograph.

Detention Design Example Calculation

Manual Calculation:

Refer to HEC 22 for a step-by-step guide to detention design including example calculations.

Software-Assisted Design:

Practitioners use various software packages to assist in the design of detention facilities. The following guidance describes the general process required for most software products.

Inputs:

1. Enter hydrologic information.
 - Users can usually enter tabular inflow hydrograph data directly, if it is available (i.e., time vs inflow). Alternatively, most software packages will assist in calculating the inflow hydrograph using precipitation and drainage area input.
 - Precipitation data consists of:
 - Rainfall intensity-duration-frequency (IDF) curves
 - The desired design storms
 - Define drainage area characteristics (sometimes referred to as catchments)
 - Area
 - Land cover (CN)
 - Times of concentration
2. Define drainage system configuration.
 - Often multiple drainage areas or subcatchments drain to one detention facility.
 - The various components of the system are often defined by nodes and reaches to calculate the aggregate runoff and time of concentration.
3. Enter assumed basin geometry.
 - Estimate the required storage volume using one of the methods described in this section.
 - The stage-storage relationship can then be defined using one of a few options depending on site constraints and information available.
 - Tabular stage-storage data can be entered, if available.
 - Or, the basin geometry can be defined.
 - A trapezoidal basin can be defined by length, width, depth, and slope.
 - If the basin has already been laid out in the site plan, the contours can be used to define the basin volume by entering the elevation and area of each of the contours.
4. Define basin outlet controls.
 - Outlet sizes such as weir lengths and orifice openings should be estimated by setting the flow equal to the pre-development peak flow.
 - Common outlet components often consist of:

- Risers
 - Orifices
 - Weirs
 - Pipes

Outputs:

Most software packages will calculate and generate plots and tables for stage vs time, storage vs time, and the outflow hydrograph. Use this data to determine if the basin design meets the flow requirements and adjust the outlet controls and basin size if it does not. Review the BMP's design guidance in section 10.6 and determine if all criteria (such as freeboard) have been met.

10.8 Common BMP Components

This section provides design guidance for components commonly found in many BMPs.

10.8.1 Forebay

Adequate pretreatment is an essential component of many BMPs. Pretreatment facilities extend the life of BMPs and reduce maintenance frequency and effort. Pretreatment is required for some BMPs and is optional for others. For example, swales do not typically require pretreatment. However, BMPs that use filtration, infiltration, or small orifices should have pretreatment to reduce sediment and debris loading.

Forebays remove coarser suspended solids and debris, dissipate energy, and prevent erosion at the BMP inlet(s). Forebays should typically be provided at any inlet that contributes concentrated flow that is over 10% of the total flow to the BMP. A forebay is not necessary in cases where inflow to the BMP is non-erosive and enters as filtered sheet flow from a device, such as a vegetated filter strip. Filter strips used as pretreatment should meet the requirements of section 10.6.1.

The forebay should be designed as a separate cell and lined or armored to prevent erosion. The bottom and sides of the forebay are typically lined with woven plastic filter fabric and riprap. The overflow spillway, which is the downslope section where runoff exits the forebay and enters the BMP, is often constructed using gabion baskets or concrete in order to form a better defined spillway. Spillways must be designed to safely convey the 10-year storm event. Figure 10.8-1 shows a typical forebay configuration.

Figure 10.8-1 - Typical forebay configuration (in a bioretention basin)
(photo courtesy of NCDOT)



Forebays should be sized for 0.1 inches of runoff per impervious acre of contributing drainage area. For example, assume a 2.5-acre impervious area drains to a BMP through a single inlet that requires a forebay. The forebay size should be determined as follows:

$$\text{Forebay Volume} = 0.1 \frac{\text{inches}}{\text{impervious acre}}$$

$$\text{Forebay Volume} = 0.1 \text{ in} \times 2.5 \text{ ac} \times \frac{1 \text{ ft}}{12 \text{ in}} \times \frac{43,560 \text{ ft}^2}{1 \text{ ac}}$$

$$\text{Forebay Volume} = 907.5 \text{ ft}^3$$

Side slopes should be limited to 2:1 or flatter where possible. Forebays should be 3 to 4 feet deep for large scale BMPs (where the drainage area is greater than 5 acres). Forebay criteria may be reduced for smaller BMPs. Although not desirable, forebays may be eliminated for small BMPs where very minimal sediment and debris are expected and inlets are designed or determined to be non-erosive.

The forebay's pretreatment volume may be located within the main basin of the BMP and included in the calculation of the total treatment volume, if needed.

A fixed vertical sediment depth marker should be installed in the forebay to measure sediment deposition.

Refer to the GDOT Riprap Forebay Special Construction Detail for more information.

10.8.2 Flow Bypass Structure

Flow bypass structures, sometimes called flow diverters or flow splitters, are often used for small-scale BMPs to prevent erosion of BMP surfaces or other modes of failure by diverting the WQ_v to the BMP and bypassing excess volume to another location. In order to use a bypass structure, prior approval from the Office of Design Policy and Support shall be required before incorporating a bypass structure into the design. BMPs that typically require flow bypass structures include infiltration trenches and sand filters, but they may also be used with other offline BMPs. Flow bypass structures

can also be used upstream of the BMP to help reduce the size of BMP outlet control system or eliminate the need for it altogether.

Flow bypass structures can be designed for a desired volume or flow rate. A weir bypass structure, as shown in Figures 10.8-2 and 10.8-3, is designed to divert a given volume. All stormwater runoff is directed into the BMP, with overflow of the weir occurring when the WQ_v is exceeded, releasing the additional volume to the stormwater drainage system. Similarly, the bypass structure can be designed such that water backs up into the bypass structure as the water level in the BMP rises. A second outlet pipe with its invert at a higher elevation releases runoff as the WQ_v is exceeded. Computer modeling is recommended for the sizing and design of these structures and backwater conditions should be evaluated.

Flow bypass structures using flow rate as the controlling factor include a small diameter pipe, orifice, or similar hydraulic control device sized for the maximum water quality peak discharge that, when exceeded, directs any additional flow to the stormwater drainage system. Figure 10.8-2 illustrates an example of this configuration assuming the outlet pipe to the BMP is sized to restrict flow. For these types of bypass structures, BMP outlet control systems must be provided as the BMP's capacity (volume) can be exceeded during low intensity storms. Refer to chapter 7 of this manual if the hydraulic control is a small diameter pipe. Refer to chapter 4 of this manual if other hydraulic control devices such as weirs and orifices are used.

Flow bypass structures are often prone to clogging which can result in roadway flooding. For this reason, flow bypass structures should be readily accessible for maintenance.

Figure 10.8-2 - Commonly used flow bypass structure (adapted from GSMM Vol. 2) (10-17)

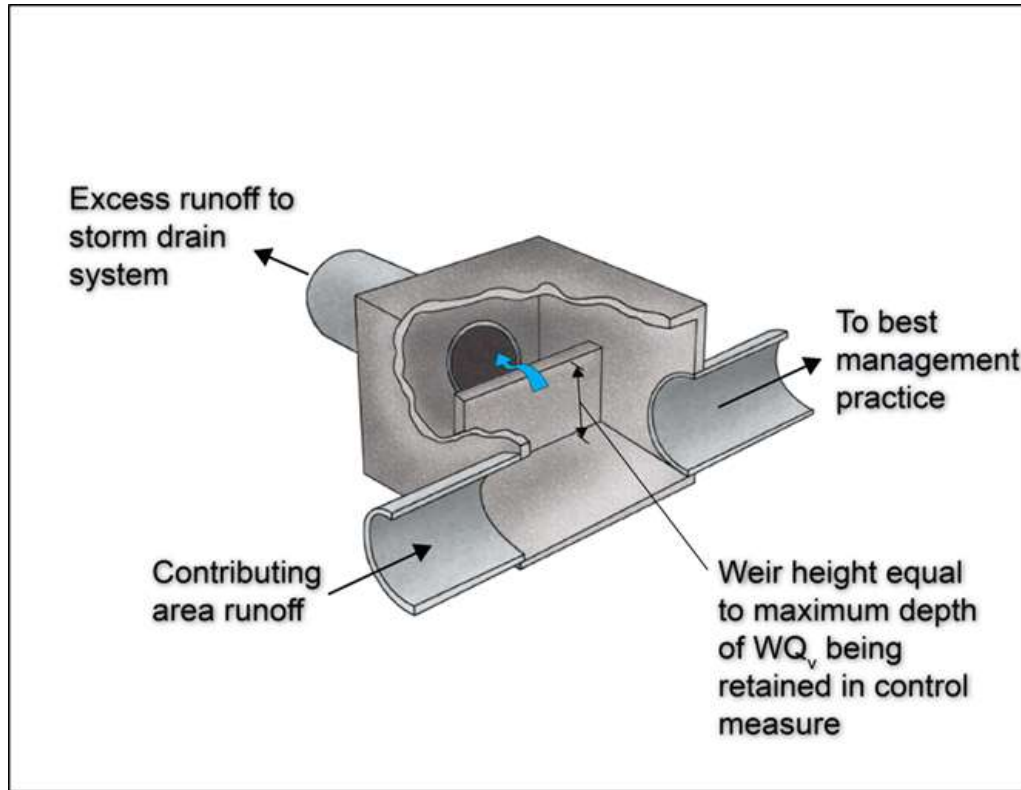

Figure 10.8-3 - A commonly used flow bypass structure configuration that bypasses flow when the capacity of the outlet pipe supplying the BMP is exceeded (photo courtesy of NCSU-BAE)



10.8.3 Underdrains

Underdrains are perforated piping used to drain and discharge the treated stormwater from filtration BMPs. Underdrains, however, may also be included in infiltration-type BMPs as a safety measure to allow the BMP to drain in the event the BMP gets clogged or is not functioning as designed. If underdrains are provided for infiltration-type BMPs, the end at the outlet control structure shall be capped. Multiple branches of underdrain pipe may be utilized when needed. Spacing between branches should be no greater than 10 feet. The branches of the underdrain should come together within the BMP such that only one pipe enters the outlet structure or penetrates the embankment. Underdrains should generally be composed of 8-inch polyethylene pipe, unless being utilized as pipe storage. Perforations are typically set at 3/8-inch diameter and spaced 6 inches on center with 4 rows running longitudinally while the pipe is placed at a minimum slope of 0.5%. These criteria are typically sufficient to provide proper drainage for most BMPs; however, it is prudent to perform calculations to verify the underdrain is adequately designed. Darcy's law can be used to determine the maximum flow rate through the BMP's media. Manning's equation can then be used to verify adequate underdrain pipe diameter. Using the size, spacing, and configuration of the perforations, the orifice equation can be used to determine if the length of the underdrain pipe is sufficient.

Refer to GDOT Specification 573, Underdrains, Supplemental Specification on Post-Construction Stormwater BMP Items, and the GDOT Underdrain Special Construction Detail for additional information.

Cleanouts should be provided at the end of each underdrain branch. Cleanouts should extend to an elevation that is appropriate for site conditions based on best professional judgment. Consideration should be given for possible inflow of stormwater should a cap become damaged or removed. Consideration should also be given to potential burial by sediment and damage by maintenance equipment.

See Figure 10.8-4 for an example of a typical underdrain installation.

Figure 10.8-4 - Typical underdrain installation (photo courtesy of NCDOT)



10.8.4 Level Spreaders

Level Spreaders for Concentrated Flow

Level spreaders with concrete troughs are typically needed to convert concentrated flow to sheet flow. Level spreaders are typically only used in conjunction with filter strips and riparian buffers but may be used for other BMPs as needed. Figure 10.8-6 provides an illustration of a typical level spreader configuration. Level spreaders should be designed to minimize the potential for erosion in downgradient areas and flow bypass systems are often needed to partially divert higher intensity storms. The erosivity of downgradient areas is a function of ground cover, slope, and soils. Flow rate is influenced by the hydrology of the contributing drainage area and the design of the flow bypass structure. The length of the level spreader can be adjusted to distribute the flow over an appropriate area.

Figure 10.8-6 - Typical level spreader configuration (photo courtesy of NCDOT)



The length of the level spreader can be determined using the same methodology for determining filter strip width. Refer to the variation of Manning's equation presented in section 10.6.1 to determine an allowable q . This method assumes an allowable depth of flow (1 or 2 inches) that will not cause erosion in the filter strip.

The design storm for the peak discharge should then be determined. Typically, the flow rate associated with the water quality volume (Q_{wq}) is used for the design of level spreaders but may vary depending on the downgradient BMP and stormwater quality goals. Refer to section 10.4.1.2.1 for guidance on calculating Q_{wq} . The length is then determined by taking Q_{wq} / q . Note that a detention BMP may be used upgradient of the level spreader to control the peak flow to the level spreader, reducing the required length. Detention BMPs may also be used as flow bypass systems. Generally, level spreaders should be limited to 100 feet. [\(10-24\)](#) It is difficult to maintain a precisely level lip for lengths in excess of 100 feet, which can cause flow to concentrate in one area of the level spreader.

Level spreaders should be a minimum of 1.5-feet deep and 2-feet wide to provide stilling of flow and allow for some sediment storage. Additional width may be desired, as shown in Figure 10.8-8, to allow maintenance equipment to enter the trough to remove sediment. Widths of 5.5 feet are generally sufficient for small equipment. The lip of the level spreader should be vertical, but the other sides can be sloped for safety (2:1) and to allow for entry by maintenance equipment (4:1). The lip of the level spreader should extend 4 inches above the downgradient ground surface to prevent vegetation from growing over the lip and causing flow to concentrate. Permanent erosion protection liners such as turf reinforcement matting (TRM), may be needed directly downgradient of the lip to stabilize the soil.

Finally, drawdown systems may be included in the design of the trough where standing water is a concern. Figures 10.8-7, 10.8-8, and 10.8-9 show a level spreader configuration used by the NCDOT.

Figure 10.8-7 - Plan view: typical level spreader layout with buffer
(adapted from NCDOT)

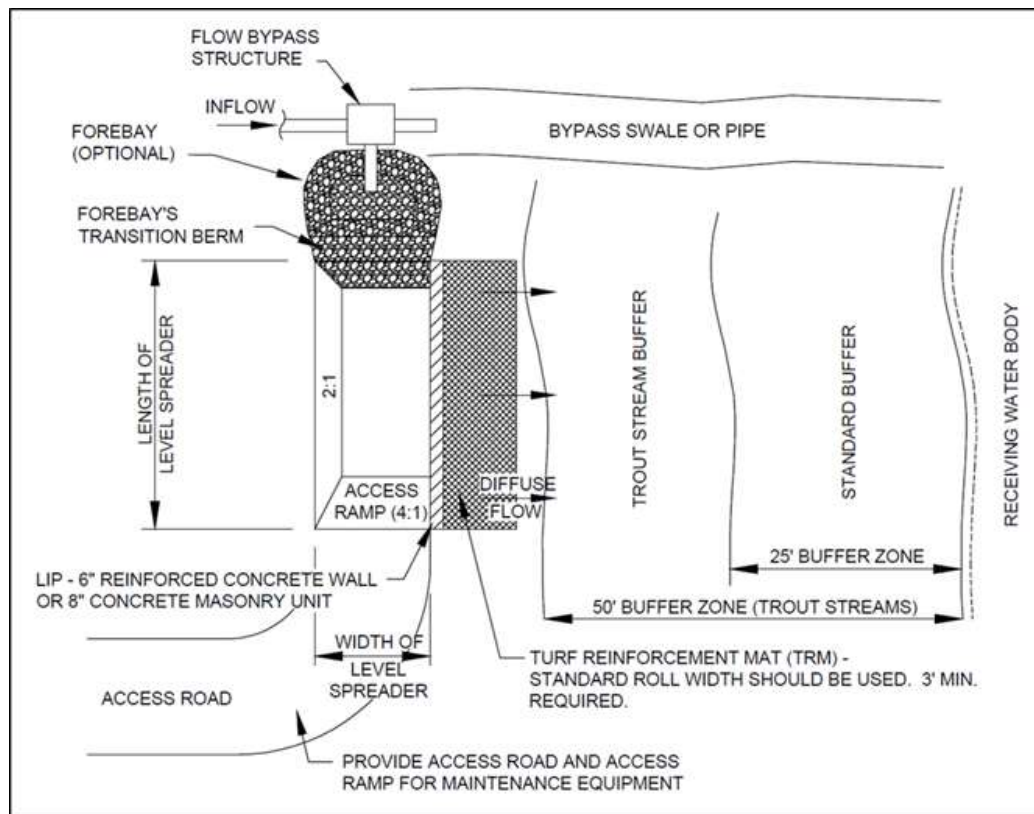

Figure 10.8-8 - Profile view: typical level spreader details and components (adapted from NCDOT)

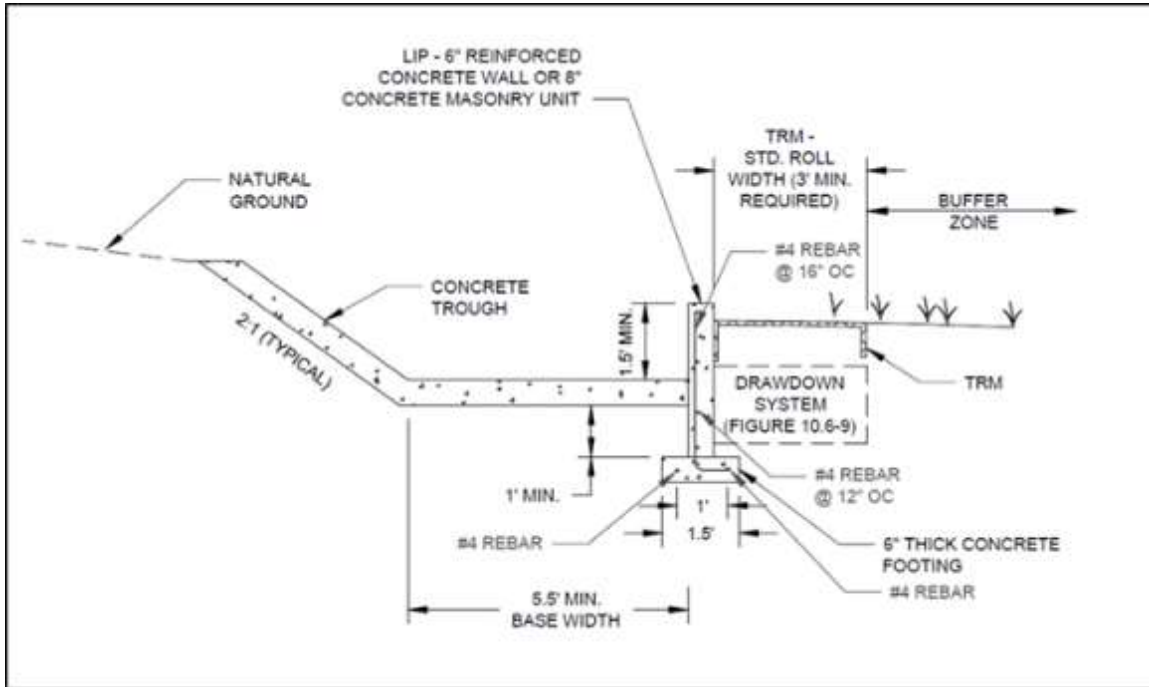
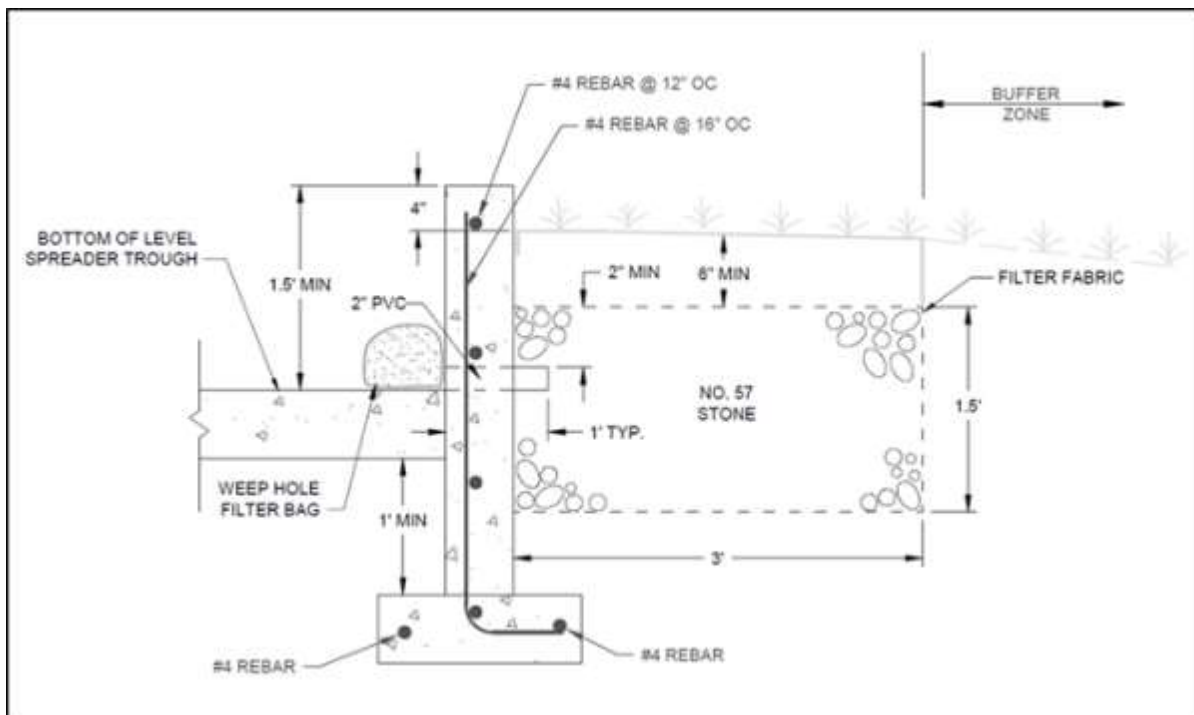

Figure 10.8-9 - Profile view: weep hole dry cell detail for level spreader (adapted from NCDOT)



10.9 Bridge Stormwater Quality Considerations

Drainage design and stormwater management are typically more challenging for bridge runoff because of additional safety hazards and environmental concerns. Increased scrutiny is often placed on stormwater runoff from bridges because these locations can create a direct link between the roadway system and surface waters or other environmentally sensitive areas (ESA). For this reason, deviation from the standard bridge deck drainage system (as described in chapter 13 of this manual) is typically required in MS4 areas to eliminate direct discharge of stormwater. However, bridge surface area and subsequent runoff volume are often small relative to the body of water that is spanned. These features should be considered when designing the bridge drainage system.

10.9.1 Bridge Stormwater Challenges

The following challenges are often associated with bridge drainage design and stormwater management:

- Structural constraints
- Limited space available for conveyance and treatment
- Limited grade available to achieve positive flow

Special drainage structures and post-construction BMPs designed for use in high-density urban areas may be needed to overcome these challenges.

For bridges in MS4 areas, direct discharge of deck drains to surface waters or other ESAs is prohibited by GDOT except under special circumstances. Additional coordination with applicable regulatory agencies is required. Note that runoff discharging from bridge deck drains that are at elevations significantly higher than the discharge point area will be dispersed as it falls and lessens the likelihood of erosion in any buffer, wetland, or other vegetated ESA. As mentioned in section 10.4, the requirements associated with stream channel / aquatic resource protection, overbank flood protection, and extreme flood protection are waived for discharge points draining directly to channels that have drainage areas larger than five square miles. Stream channel / aquatic resource protection requirements are also waived if the peak flow is less than 2.0 ft³/s. Bridges over large bodies of water, such as the Intracoastal Waterway, produce relatively little stormwater runoff when compared to the water body itself, and collecting and conveying this runoff for treatment is often not practicable or feasible. In such instances, stormwater treatment is not required.



10.9.2 Minimizing Direct Discharge

Closed deck drainage systems are often necessary where direct discharge is prohibited. A closed deck drainage system is a network of pipes below the deck drains that captures and conveys runoff to the bridge ends where it is treated by post construction stormwater controls before discharging to the water body. Roadway, bridge, and hydraulics designers should coordinate closely to create an integrated stormwater system that meets drainage and water quality requirements.

Closed deck drainage systems are costly to construct and present a maintenance burden (including costs and safety issues). Design guidance for closed deck drainage systems is provided in chapter 13 of this manual. Alternatives to closed deck drainage systems include:

1. Deck drains can sometimes be shifted such that discharge over the water body or ESA is avoided. Follow the guidance presented in chapter 13 of this manual and HEC-21 [\(10-44\)](#) to confirm that the safety of the motorist is not compromised.
2. Widening the bridge to increase the shoulder width can sometimes allow runoff to be conveyed safely via the gutter to the bridge abutments, eliminating deck drains altogether.
3. Similarly, shoulders can be shifted on superelevated bridges such that the shoulder on the low side is wider than the shoulder on the high side, providing more space to convey runoff via the gutter.
4. Designing the bridge to crest in the center essentially halves the conveyance capacity that would be required by a bridge with all runoff draining to one side. This may or may not assist in eliminating the need for a closed deck drainage system. Regardless, designing the bridge to crest in the center usually provides twice as much space to manage half the runoff.

10.9.3 Bridge Best Management Practices

There are several practices that should be considered for bridge drainage designs:

Roadway Drainage System Integration

The roadway drainage system must be integrated with the bridge drainage system to effectively convey runoff to the water body. Roadway runoff should be transported down the embankment through an appropriately designed channel (chapter 5) or a drainage structure (chapter 7). Appropriate energy dissipation should be provided at the discharge location (chapter 8).

Slope Stabilization and Ground Cover

Embankments and surrounding areas should have adequate ground cover and stabilization. Careful consideration should be given to materials selected and as to whether or not conditions (e.g., stream stability, shade beneath the bridge) will support vegetative growth. Guidance for riprap aprons at bridges can be referenced in chapter 12, section 1.7 of this manual.



Energy Dissipation

Energy dissipation is typically needed at the discharge of all conveyances and may be required for areas below deck drains to mitigate the impact of falling runoff and the channelization of flow from multiple deck drains. Refer to chapter 8 of this manual for additional guidance on energy dissipation design.

Post-Construction Best Management Practices

The post-construction BMPs presented in section 10.6 should be used to meet stormwater management requirements. Refer to sections 10.2 and 10.6 of this manual for further guidance on MS4 permit requirements and post-construction BMPs.



10.10 Safety Considerations for Stormwater BMPs

Stormwater best management practices can present unique safety concerns to motorists, the public, and GDOT maintenance personnel. Guidance for designing an adequate drainage system for the roadway is covered in chapters 6 and 7 of this manual. Dam safety requirements were previously discussed in this chapter and are further defined in the Georgia Safe Dams Act of 1978 (OCGA 12-5-370). Downstream flooding is another concern and is addressed in section 10.2. This section addresses safety concerns associated with stormwater BMPs.

10.10.1 Motorist Safety

Motorist safety is a primary concern for drainage design. Some BMPs or their components can present road hazards and must be placed outside of the clear recovery zone. Refer to the AASHTO Roadside Design Guide (2011) [\(10-2\)](#) for additional information relating to clear recovery zone requirements.

10.10.2 Public Safety

While some BMPs are associated with interstate highway systems, others are located in areas that are frequented by pedestrians and the general public. Many BMPs create a temporary (during storm events) or permanent pool of standing water and can present a drowning hazard. The type of BMP, its configuration, and the surrounding areas (e.g., location of nearby schools or playgrounds) should be taken into consideration when determining possible safety measures. Steep embankments and drop-offs should be avoided and safety benches should be provided where possible to minimize the potential for slips and falls. Railings may be an alternative in some areas. Trash racks should be provided over risers to discourage entry by people and animals. Fencing is often added around BMPs to prevent the public from entering the area. Most facilities that meet one or both of the following criteria will require perimeter fencing:

- Stormwater facilities that are located in areas that are subject to frequent visits by the public and/or located adjacent to schools, playgrounds, recreation areas, or urban areas
- Stormwater facilities such as natural ponds, detention ponds, and water quality ponds that contain water over 24-inches deep for an extended period of time (greater than 48 hours)

Perimeter fencing should meet the following guidelines:

- 6-foot height chain link wire fence, in accordance with GDOT standard specification 643.
- Self-closing and self-latching gates
- Adequate space to be provided for routine maintenance

Although fencing may be a good option, in some configurations, it can inhibit maintenance and diminish the aesthetic appeal of the BMP.

BMPs are designed to collect pollutants that are washed off the roadway. For this reason, swimming and fishing is typically discouraged in BMPs with permanent pools. Consider posting signage warning the public of these dangers.

10.10.3 Maintenance Personnel Safety

The safety of maintenance personnel should also be considered during the design process. Maintenance personnel will need to exit the roadway safely to access the BMP. The minimum width of maintenance access drives is 12 feet, though 16 feet is preferable, and the maximum slope is 15%. Safety benches should be provided where applicable to facilitate mowing and other activities. A minimum of 10 feet (14 feet preferable) should be provided between fences and BMPs to allow for mowing and maintenance activities. Outlet structures and other components should be located and designed with maintenance and safety in mind. When the minimum widths cannot be met, consult the State Maintenance Office.

Chapter 10 References

1. American Association of State Highway and Transportation Officials (AASHTO). 2008. [Practitioner's Handbook](#).
2. American Association of State Highway and Transportation Officials (AASHTO). 2011. Roadside Design Guide, 4th Ed.
3. American Concrete Pipe Association (ACPA) May 2008. [Design Data 41 - Manhole Flotation](#).
4. Eck, Bradley J., et. al. 2012. Water Quality of Drainage from Permeable Friction Course. Journal of Environmental Engineering. American Society of Civil Engineers (ASCE).
5. Winston, R.J., et.al. 2012. Evaluation of Permeable Friction Course (PFC), Roadside Filter Strips, Dry Swales, and Wetland Swales for Treatment of Highway Stormwater Runoff. NCDOT Research Project 2007-21. North Carolina Department of Transportation.
6. [Bioretention - Watershed Benefits](#). Low Impact Development Urban Design Tools. 04 April 2014.
7. Brown, S.A., Schall, J.D., Morris, J.L., Doherty, C.L., Stein, S.M., Warner, J.C. 2009, Urban Drainage Design Manual, [Hydraulic Engineering Circular No. 22](#), FHWA-NHI-10-009. Federal Highway Administration (FHWA), U.S. Department of Transportation, Washington, D.C.
8. Cappiella, Karen, Lisa Fraley-McNeal, Mike Novotney, and Tom Schueler. "[Article 5: The Next Generation of Stormwater Wetlands](#)." EPA Wetlands and Watersheds Article Series (2008) Center for Watershed Protection. 04 April 2014.
9. Center for Watershed Protection (CWP), 1996. [Design of Stormwater Filtering Systems](#). Prepared for Chesapeake Research Consortium.
10. Federal Highway Administration (FHWA) and U.S. Department of Transportation. 2007. [Hazardous Wildlife Attractants On or Near Airports](#), 150/5200-33B.
11. Ferguson, Bruce K. and Thomas Neil Debo. 1990. [On-site Stormwater Management](#).
12. Georgia Department of Natural Resources (GADNR). Environmental Protection Division (EPD). Erosion and Sedimentation Control. [O.C.G.A. 391-3-7-.05](#)
13. Georgia Department of Natural Resources (GADNR). Environmental Protection Division (EPD). Georgia Safe Dams Act of 1978. [O.C.G.A. 12-5-370 through 12-5-385](#).
14. Georgia Department of Natural Resources (GADNR). Environmental Protection Division (EPD). Watershed Protection Branch. 2017. [Stream Buffer Mitigation Guidance](#)
15. Georgia Stormwater Management Manual (GSMM - Blue Book), 2009. [Coastal Stormwater Supplement](#). First Edition.
16. Georgia Stormwater Management Manual (GSMM - Blue Book), 2001. [Stormwater Policy Guidebook](#). First Edition, Vol. 1.
17. Georgia Stormwater Management Manual (GSMM - Blue Book), 2001. [Technical Handbook](#). First Edition, Vol. 2.

18. Georgia Stormwater Management Manual (GSMM – Blue Book), 2016. [Technical Handbook](#). 2016 Edition, Vol. 2.
19. Georgia Soil and Water Conservation Commission (GSWCC – Green Book), 2016. "[Manual for Erosion and Sediment Control in Georgia](#)," 2016 Edition.
20. Hirschman, David J., John Kosco. 2008. "[Managing Stormwater in Your Community: A Guide for Building an Effective Post-Construction Program](#)". Center for Watershed Protection, Ellicott City, MD.
21. Hunt, William F., A. P. Davis, R. G. Traver. 2011. Meeting Hydrologic and Water Quality Goals through Targeted Bioretention Design, *Journal of Environmental Engineering*, (accepted – October 2011).
22. Hunt, William F., and William G. Lord. "[Bioretention Performance, Design, Construction, and Maintenance](#)." 2006. North Carolina Cooperative Extension Service.
23. Inman, Ernest J. United States Geological Survey (USGS). 1994. [Flood-Frequency Relations for Urban Streams in Georgia](#)-1994 Update. Water Resources Investigations Report 95-4017
24. Maryland Department of the Environment. 1987. [Design Procedures for Stormwater Management Extended Detention Structures](#). Maryland Department of Natural Resources. Annapolis, MD.
25. National Oceanic and Atmospheric Administration (NOAA), 2013. "[NOAA Atlas 14, Vol. 9](#)" Precipitation-Frequency Atlas of the United States"
26. North Carolina Department of Transportation (NCDOT) 2014. [Stormwater Best Management Practices Toolbox](#). North Carolina Department of Transportation. Hydraulics Unit.
27. NCHRP 2006. [Evaluation of Best Management Practices for Highway Runoff Control](#): Low Impact Development Design Manual for Highway Runoff Control (LID Design Manual). National Cooperative Highway Research Program, Transportation Research Board, National Research Council.
28. NCDENR. 2009. [Stormwater Best Management Practices Manual](#). North Carolina Department of Environment and Natural Resources, Division of Water Quality, Raleigh, NC.
29. NCHRP 2013. [Synthesis 444: Pollutant Load Reductions for Total Maximum Daily Loads for Highways](#). National Cooperative Highway Research Program, Transportation Research Board, National Research Council.
30. Passeport, E., W. F. Hunt, D. E. Line, R. A. Smith, and R. A. Brown. 2009. "Field Study of the Ability of Two Grassed Bioretention Cells to Reduce Stormwater Runoff Pollution." *Journal of Irrigation and Drainage Engineering*, 135(4): 505-510.
31. Pennsylvania Department of Transportation (PennDOT). 2015. [Drainage Manual](#). Publication 584
32. Schall, James D., Thompson, Philip L., Zerges, Steve M., Kilgore, Roger T., Morris, Johnny L. 2012, Hydraulic Design of Highway Culverts Third Edition, [Hydraulic Design Series No. 5](#), FHWA-HIF-12-026. Federal Highway Administration (FHWA), U.S. Department of Transportation, Washington, D.C.

33. United States Department of Agriculture (USDA). Natural Resources Conservation Service (NRCS). 1997. [Ponds – Planning, Design, Construction. Agricultural Handbook 590.](#)
34. United States Department of Agriculture (USDA). Natural Resources Conservation Service (NRCS). 1986. [TR55 Urban Hydrology for Small Watersheds](#)
35. United States Environmental Protection Agency (USEPA). 2013. [Greening EPA Glossary.](#)
36. United States Environmental Protection Agency (USEPA). 2012. Office of Wetlands, Oceans, and Watersheds. Terminology of Low Impact Development
37. Virginia Department of Conservation and Recreation (VADCR). 2011. [Virginia DCR Stormwater Design Specification No. 9: Bioretention.](#)
38. Virginia Department of Transportation (VDOT). 2002. [Drainage Manual.](#) Location and Design Division Hydraulics Section.
39. Washington State Department of Transportation (WSDOT) 2011. [Highway Runoff Manual.](#) M 31-16.03. Washington State Department of Transportation.
40. West Virginia Department of Environmental Protection (WVDEP). 2012. [West Virginia Stormwater Management and Design Guidance Manual.](#)
41. Wycoff, R. L. and Singh, U. P. (1976), Preliminary Hydrologic Design of Small Flood Detention Reservoirs. Journal of the American Water Resources Association (JAWRA), 12: 337–349. doi: 10.1111/j.1752-1688.1976.tb02683.x
42. Young, G.K, Walker, S.E., Chang, F. 1993, Design of Bridge Deck Drainage, [Hydraulic Engineering Circular No. 21](#), FHWA-SA-92-010. Federal Highway Administration (FHWA), U.S. Department of Transportation, Washington, D.C.

Chapter 11. Stream & Wetland Restoration Concepts - Contents

Chapter 11. Stream & Wetland Restoration Concepts - Contents	11-i
11.1 Introduction.....	11-1
11.2 Permitting	11-1
11.3 Stream Design and Restoration	11-3
11.3.1 Introduction.....	11-3
11.3.2 Definitions.....	11-3
11.3.3 Natural Stream Design	11-4
11.3.3.1 Intent of Natural Stream Design	11-5
11.3.3.2 Recommended Design Approach	11-8
11.4 Wetland Restoration/Mitigation.....	11-9
Chapter 11 References.....	11-12

Chapter 11. Stream & Wetland Restoration Concepts

11.1 Introduction

This chapter will discuss the relocation of streams as well as the restoration concepts related to streams and wetlands.

The designer should consult other chapters in this manual, as appropriate, for supporting information related to stream and wetland restoration concepts. For example, chapter 4 presents general hydrology and hydraulic concepts, while, chapter 5 introduces stream topics such as: stream morphology, cross sections, Manning's n values, calibration, one-dimensional gradually varied flow profile analysis, and a few special analysis techniques. Following are the main topics presented in this chapter:

- Permitting requirements for stream and wetland restoration projects
- Natural stream studies and assessments of existing stream channels
- Guidance on stream restoration projects
- Guidance on wetland restoration projects

This chapter is not intended to be an all-encompassing guidance document on stream design or relocation, stream restoration, or wetland restoration. These types of design elements are part of a specialized field which requires an experienced designer. This chapter will present an overview of typical stream relocations and restoration concepts followed by an overview of wetland restoration design. It is recommended, however, that the designer consult outside references as well as the various references cited throughout chapters 5 and 11 for actual stream relocation and wetland design procedures.

11.2 Permitting

Stream and/or wetland mitigation is often an applicable requirement under the CWA, Section 404, as administered by USACE, and Section 401 administered by GAEPD. USACE and GAEPD may require mitigation for the loss of streams and/or wetlands that occurs when highways and other facilities are constructed. Compensatory Mitigation for Losses of Aquatic Resources, (Federal Register 2008) issued by USACE and USEPA, defines the three compensation mechanisms that are used to mitigate for the loss of wetlands; permittee-responsible compensatory mitigation, mitigation banks, and in-lieu fee mitigation. Each type must have mitigation plans which include the same 12 fundamental components:

- Objectives
- Site selection criteria
- Baseline information (for impact and compensation sites)
- Credit determination methodology
- Mitigation work plan
- Maintenance plan

- Ecological performance standards.
- Monitoring requirements
- Long-term management plan
- Adaptive management plan
- Financial assurances
- Site protection instruments (e.g., conservation easements)

Purchasing mitigation bank credits is the preferred mitigation method, because it reduces the risks and uncertainties associated with permittee-responsible compensatory mitigation. In-lieu fee program credits are second in the preference hierarchy because they may involve larger, more ecologically valuable compensatory mitigation projects, as compared to permittee-responsible mitigation. Thus, this chapter is intended to provide a general guideline on the subject and may also be useful when temporary impacts to streams and/or wetlands have been permitted and impacted areas must be returned to existing conditions prior to project completion.

Regulatory Agency Consultation and Permitting

Prior to the initiation of any activity within a stream or wetland, or the design of a mitigation plan, consultation with the appropriate regulatory agency must be conducted and appropriate permits, if any, need to be obtained. A list of the most commonly required permits/approvals and their appropriate regulating authority is provided below.

- Section 404 Permit – USACE
- Section 10 Permit – USACE
- Section 401 Certification (Required before 404) – GAEPD

In addition to the permits listed above, Georgia's Erosion and Sedimentation Control Rules regulate the vegetated buffers of certain state waters. State waters designated as warm waters (i.e., non-trout supporting) receive buffer protection if they display a continuous point of wretched vegetation and receive base flows. Warm water perennial streams, intermittent streams, and open waters typically receive buffer protection while ephemeral streams and wetlands generally do not. State waters designated as cold waters (i.e., trout supporting) receive buffer protection if they display a continuous point of wretched vegetation regardless of the presence of base flows. Cold water perennial streams, intermittent streams, ephemeral streams, and open waters typically receive buffer protection while wetlands generally do not. Wetlands typically do not require a buffer unless they meet the state's definition of open water. Buffered warm state waters receive a 25-foot protected buffer and buffered cold state waters receive a 50-foot protected buffer. Any encroachment within the designated buffer would require a variance from GAEPD unless the activity has been exempted from buffer requirements. Buffer encroachments that will occur in conjunction with a bridge or culvert may be exempt from the need for a buffer variance. As of July 2007, the roadway drainage feature exemption includes/exempts all buffer encroachments within the 50-foot from the edge of culvert, or 100-foot from the edge of bridge footprint. This exemption also extends to the project right-of-way, though all encroachments must be necessary for construction to be considered exempt. The July 2007 interpretation includes all tributaries or unassociated state waters, including the water being crossed. An ecology specialist should be

consulted to verify the presence/absence of buffered state waters and determine the need for a variance.

Designers should note that additional riparian buffer protections may be imposed by local governments (e.g., county, city, etc.). An ecology specialist should be consulted to verify the presence or absence of local riparian buffer protections and determine the need for a variance.

11.3 Stream Design and Restoration

11.3.1 Introduction

The general goal of stream design and restoration is to promote the use of ecological processes (physical, chemical, and biological) and minimally intrusive solutions to restore self-sustaining stream corridor functions. By developing and selecting appropriate alternatives and solutions, and making informed management decisions, a stream design and restoration plan can be generated. Designers may choose to reference one of the following technical documents related to stream stability and restoration/rehabilitation approaches:

- *Stream Restoration: A Natural Channel Design Handbook* [\(11-3\)](#)
- Hydraulic Design Series No. 6 (HDS-6), *Highways in the River Environment* [\(11-7\)](#)
- Hydraulic Engineering Circular No. 20 (HEC-20), *Stream Stability at Highway Structures* [\(11-5\)](#)
- *National Engineering Handbook, Part 654 Stream Restoration Design* [\(11-12\)](#)
- *Applied River Morphology* [\(11-8\)](#)
- *Hydraulic Design of Stream Restoration Projects* [\(11-11\)](#)
- *Stream Corridor Restoration: Principles, Processes, and Practices* [\(11-9\)](#)

Whether a highway project involves restoration or rehabilitation activities, the complexities of the stream corridor system need to be considered.

11.3.2 Definitions

The following definitions are provided as they apply to stream systems and their intended meaning within this chapter.

Stream: (In this chapter, also referred to as “natural stream” and assumes a stream is located in an undeveloped watershed.) A stream is a natural channel with its size and shape determined by natural forces. It is usually compound in cross section with a main channel for conveying flows and a floodplain to transport flood flows, unless it is a highly incised channel, in which case no active floodplain exists.

Ephemeral Stream: A stream that has flowing water only during, and for a short duration after, precipitation events during a typical year is an ephemeral stream. Ephemeral stream beds are located above the water table year-round and groundwater is not a source of water for the stream. Runoff from rainfall is the primary source of water for stream flow.

Intermittent Stream: An intermittent stream has flowing water during certain times of the year, when groundwater provides water for stream flow. During dry periods, intermittent streams may not have flowing water. Runoff from rainfall is a supplemental source of water for stream flow.

Perennial Stream: A perennial stream has flowing water year-round during a typical year. The water table is located above the stream bed and groundwater is the primary source of water for stream flow. Runoff from rainfall is a supplemental source of water for stream flow.

Restoration: The process of repairing damage to the diversity and dynamics of ecosystems. Ecological restoration is the process of returning an ecosystem as closely as possible to pre-disturbance conditions and functions. Implicit in this definition is that ecosystems are naturally dynamic. It is therefore not possible to recreate a system exactly. The restoration process reestablishes the general structure, function, and dynamics of the stream, but sustains the behavior of the ecosystem.

Rehabilitation: Rehabilitation is making the land useful again after a disturbance. It involves the recovery of ecosystem functions and processes in a degraded habitat. Rehabilitation does not necessarily reestablish the pre-disturbance condition, but does involve establishing geological and hydrologically stable landscapes that support the natural ecosystem mosaic.

State Waters: State waters are defined in Section 12-7-3(16) of the Georgia Erosion and Sedimentation Act as "any and all rivers, streams, creeks, branches, lakes, reservoirs, ponds, drainage systems, springs, wells and other bodies of surface or subsurface water, natural or artificial, lying within or forming a part of the boundaries of the State, which are not entirely confined and retained completely upon the property of a single individual, partnership, or corporation." State waters are regulated by the GAEPD and may receive buffer protection.

11.3.3 Natural Stream Design

As a general practice, the designer should make an effort to minimize or avoid impacts to streams. This may be possible by modifying the proposed roadway design to include steeper slopes or retaining walls. However, if stream restoration and/or rehabilitation is warranted, there are a wide range of design approaches available, ranging from relatively simple methods based on stream classification systems, to complex two- and three-dimensional numerical models that analyze water and sediment discharge conditions (reference chapter 5 for more detailed information and references on these models). Simpler methods, including those based on stream classification concepts, do not include adequate consideration of hydraulic and sediment transport issues.

Engineering analysis of the hydraulic and sediment transport conditions in a restoration project is important to the long term success of a stream. Many restoration schemes emphasize more "natural" solutions (e.g., timber structures) that may be stable under normal flow conditions, but under flood conditions, suffer widespread failure. For channels in a truly "natural" environment, such failures may be of little consequence. However, for channels adjacent to highways, and particularly channels located in urban areas where significant infrastructure is at risk, such failures are not acceptable. In these situations, an engineering-based analysis is necessary to address all important issues, including an appropriate evaluation of sediment transport conditions.

11.3.3.1 Intent of Natural Stream Design

The general intent of natural stream design for a relocated stream reach is to preserve the conditions which exist within the larger stream system. The relocated reach should attempt to match, as closely as possible, the existing stream in terms of the following:

- Stream Planform
- Stream Vertical Profile
- Habitat features
- Existing Floodplains

Each of these existing stream features is discussed in more detail in the following sections.

Stream Planform

Preserving the length and sinuosity, two main factors of the stream planform, is important in natural stream design. Maintaining the length of the stream is integral to maintaining the flood routing characteristics and stream profile. In addition to the meander characteristics, the designer should attempt to duplicate the existing sinuosity ratio (Figure 11.1), if present. Sinuosity is influenced and determined by the region of the state, similar to the ecoregions shown in Figure 11.4. For example, stream channels tend to be more sinuous in the coastal plains region than in the piedmont region, where streams have a greater number of riffles and shoals. Additionally, the proposed design should be based on the relationship between sinuosity and vertical stream structure, since pools tend to form in the outside portions of bends, while riffles tend to form in the straight sections between them.

Figure 11.1 - Sinuosity Ratio

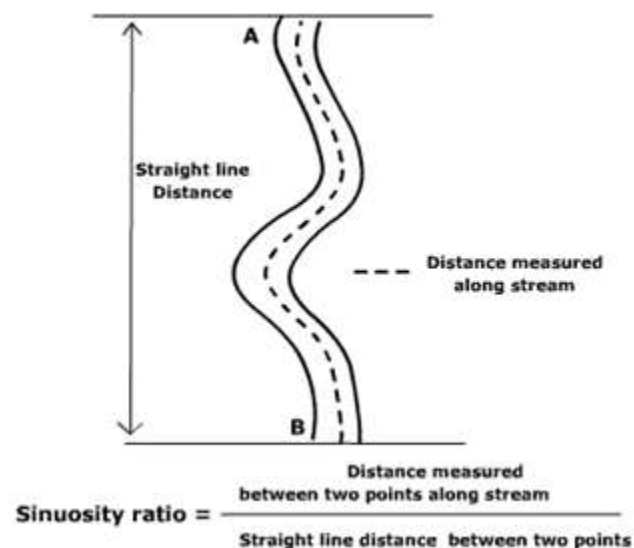

Stream Vertical Profile

Vertical structures associated with natural channels are pools, riffles, runs, glides, and steps.

Pool and riffle structures connected by runs or glides are most often associated with alluvial streams on a sinuous alignment. As illustrated in Figures 11.2 and 11.3, the structure consists of a

series of one or more deep pools interspersed with riffles composed of rock or gravel. These riffles and pools are connected by smooth, unbroken flow areas known as runs or glides. When an existing stream displays these types of vertical structures, the designer should examine the existing channel bottom profile and note the following:

- Length and depth of the pools
- Length and local slope of the riffles
- Gradient of the runs or glides

Figure 11.2 - The Stream Reach

Reference: West Virginia Department of Environmental Protection

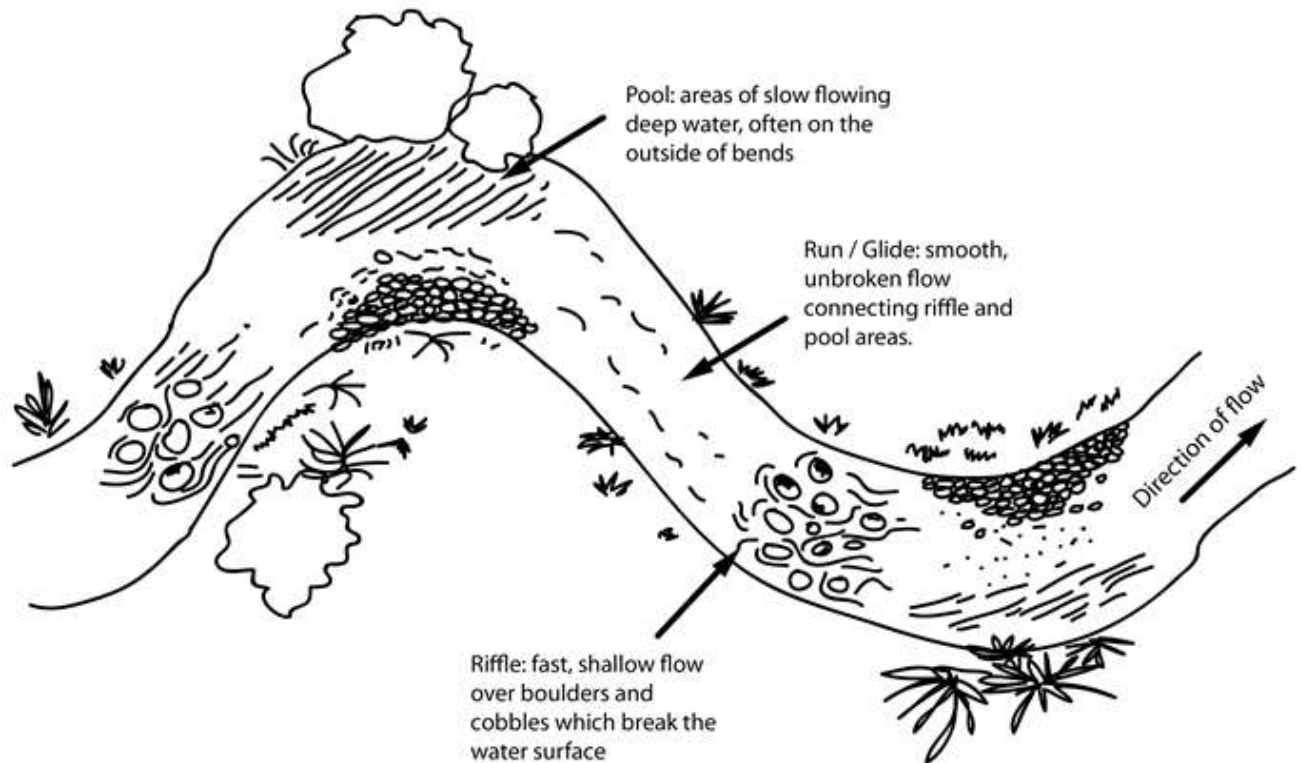

Figure 11.3 - Stream structure example
Reference: Virginia Tech University



Step structures are most often associated with steep natural threshold streams flowing through boulders or bedrock. They consist of a series of short comparatively flat reaches followed by steep drops. When an existing stream displays this type of vertical structure, the designer should note the following:

- Length and local slope of each step
- Drop height between steps
- Materials (bedrock, boulders, etc.) forming each step

The designer may also need to evaluate the overall floodplain (valley) slope in addition to the local channel slope. These two slopes can be different for streams with a high degree of sinuosity. The floodplain slope is necessary for determining flood elevations for large discharge events. On the other hand, the local channel slope is used to determine the channel forming discharge which is then used for a number of design parameters, including the selection and design of mitigation practices.

Existing Floodplains

A stable natural stream usually consists of a channel section which conveys low flows and overbanks which will convey flows when the stream is at its bankfull elevation, which is typically a 2-year recurrence interval. Where this situation exists, the goal of the natural stream design for a relocated channel should be to maintain the existing stream cross section. While it is recognized that this may not be practical in all situations, this would include duplicating the existing top of bank elevations, as well as the floodplain widths. As a rule of thumb, the floodplain width is preferred to be five to ten times the width of the bankfull elevation width, and a bare minimum of three times the

width in areas where not possible. The larger this ratio becomes is usually an indicator of the stream quality.

There may be a temptation by the designer to increase the size of the channel in order to decrease the required size of the floodplain. However, this is not recommended since it may lead to stability problems, especially for alluvial streams. In addition, there may be ecological impacts if the frequency of flooding on the overbanks is reduced.

As required by FEMA, the designer should check that the flood elevations in the proposed condition do not exceed the flood elevations in the existing condition for both the relocated reach and upstream of the project site. The designer should conduct hydraulic analyses for both the existing and proposed conditions to check flood elevations for both the design discharge (refer to GDOT Design Policy Manual for design flood frequency) and the 100-year discharge. These analyses should assume that floodplain conditions, including riparian vegetation, are the same in the proposed condition as they are in the existing condition.

11.3.3.2 Recommended Design Approach

The first step in a channel restoration project is to identify the problems observed in the reach of concern. The stream reconnaissance techniques and field checklists provided in FHWA's publication, HEC-20, [\(11-5\)](#) support a determination of the nature and extent of the observed problems. A rapid assessment methodology such as that presented in HEC-20, [appendix D](#), [\(11-5\)](#) can help in evaluating the severity of the problem.

To determine the cause of the stream instability, a qualitative assessment of important geomorphic factors (reference HEC-20 [\(11-5\)](#) chapter 2) can provide an initial indication, although a more detailed analysis which follows the Level 1 and Level 2 procedures will be required (reference HEC-20 [\(11-5\)](#) chapter 3). Understanding land use change in the contributing watershed and its effects on the delivery (both timing and quantity) of water and sediment to the stream system is critical in identifying the complex interrelationships that are responsible for stream instability.

To develop a restoration solution for a degraded stream, it is often useful to review the existing stream system and a variety of stream channel classifications based on planform, bed form, bed materials, bank materials, sediment load, and hydraulic and geomorphic parameters to determine potential stream types consistent with watershed and valley features. In addition, a successful restoration project will require developing a stable form for the stream considering the existing hydrologic and sediment regime. The designer must develop a stream that is stable laterally (in planform) and vertically (in profile).

The AASHTO publication, Highway Drainage Guidelines, [\(11-1\)](#) contains detailed guidelines for stream modification and mitigation practices, particularly regarding aquatic habitat and wetland functions. The AASHTO publication, Model Drainage Manual, [\(11-2\)](#) recommends a number of strategies to develop channel mitigation geometries when disturbance of a channel is determined to be unavoidable. The Model Drainage Manual suggests three alternatives, along with conceptual sketches, for maintaining a stream's functional value. These alternatives include: grade control structures, fish habitat structures, and bendway bank protection.

The ultimate test of restoration design is the ability of the reconfigured channel to achieve a state of dynamic equilibrium considering the size and volume of sediment delivered from upstream. The sediment continuity concept, presented in HEC-20, [\(11-5\)](#) can be used for a preliminary evaluation of

stream system stability; however, a more detailed model may be required for large rivers or complex projects.

In terms of analytical complexity, an intermediate approach based on application geomorphology, channel forming discharge analysis, one-dimensional hydraulic analysis and sediment transport calculations is provided in the United States Army Corps of Engineers (USACE) publication, *Hydraulic Design of Stream Restoration Projects*.⁽¹¹⁻¹¹⁾ This comprehensive methodology recognizes that regardless of the goals of the rehabilitation project, the fundamentals of planning activities should be followed, including the following general steps:

- Preliminary planning to establish the scope, goals, preliminary objectives, and general approach for restoration.
- Baseline assessments and inventories of project location to assess the feasibility of preliminary objectives, to refine the approach to restoration, and to provide for the project design.
- Design restoration projects to reflect objectives and limitations inherent to the project location.
- Evaluate construction to identify, correct, or accommodate for inconsistencies with project design.
- Monitor parameters important for assessing goals and objectives of restoration.
- Based on these guidelines, a systematic approach to initiating, planning, analyzing, implementing, and monitoring of stream restoration and rehabilitation projects can be developed.

11.4 Wetland Restoration/Mitigation

As noted in section 11.2, mitigation credits are the preferred method of mitigation. If neither the mitigation credit nor the in-lieu program credit method is possible, and GDOT has indicated wetland restoration will be acceptable for the project, the designer should consider the following information. As stated in the beginning of this chapter, wetland restoration projects, often referred to as wetland mitigation, are a multi-disciplinary undertaking, requiring successful solutions to problems of hydrology, vegetation, soil, wildlife habitat, and pollutant/flood abatement in order to address Section 404 regulations. The lead role in design and implementation of wetland mitigation projects is usually a wetland specialist, who may employ the expertise of other specialists such as hydrologists, botanists, foresters, landscapers, construction engineers, soil scientists, and wildlife biologists. A description of each expert's role and various specific construction techniques required for a wetland mitigation project is beyond the scope of this chapter. The goal of this section, therefore, is to present highlights of the subject that will inform a hydraulics professional on aspects that should be given consideration. For further information on wetland design, the reader is referred to the following list of references:

- Planning Hydrology for Constructed Wetlands ⁽¹¹⁻⁶⁾
- Wetland Delineation Manual ⁽¹¹⁻¹⁰⁾
- HDS-2 Highway Hydrology – chapter 9 ⁽¹¹⁻⁴⁾

Desired mitigation functions might include the following: special habitat for a targeted wildlife species, flood storage within a flood prone watershed, sediment and stormwater pollutant trapping within an impaired watershed, protection from erosion in areas affected by tides and currents, groundwater recharge or discharge areas, and/or recreational and educational values. An interdisciplinary approach to wetland design provides for the development of desirable functional goals and success criteria that meet regulatory standards.

Considerations for the following wetland parameters should be made by the interdisciplinary design team:

- Site selection (based on USACE district requirements)
- Wetland types (replacement in kind)
- Suitable soils (developing hydric soils)
- Vegetation (consider wetland type and ecoregion of the state, Figure 11.4)
- Hydrology
- Water balance (Water Budget)
- Water control structures (to allow variable depths)
- Construction constraints (site access, seasonal construction period, adherence to plans)

Figure 11.4 - Level III and IV Ecoregions of Georgia
Reference: EPA

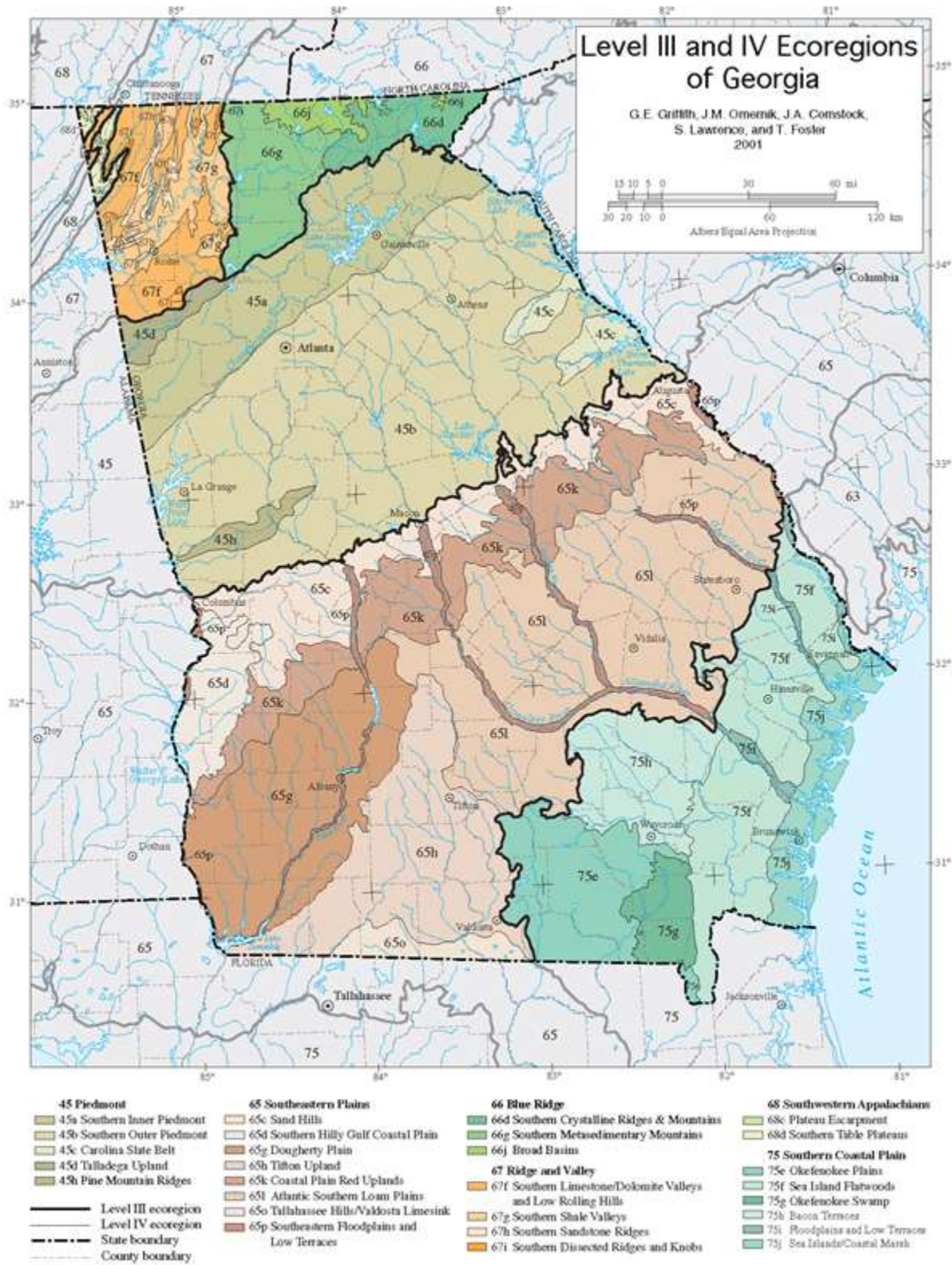

Chapter 11 References

1. American Association of State Highway and Transportation Officials (AASHTO). 2007. Highway Drainage Guidelines, 4th Ed.
2. American Association of State Highway and Transportation Officials (AASHTO). 2005. Model Drainage Manual, 3rd Ed.
3. Doll, B.A., G.L. Grabow, K.R. Hall, J. Halley, W.A. Harman, G.D. Jennings
4. and D.E. Wise, 2003. [Stream Restoration: A Natural Channel Design Handbook](#). NC Stream Restoration Institute, NC State University. 128 pp.
5. Federal Highway Administration. 2002, Highway Hydrology, [Hydraulic Design Series No. 2](#), NHI-02-001. Federal Highway Administration (FHWA), U.S. Department of Transportation, Washington, D.C
6. Lagasse, P.F., Zevenbergen, L.W., Spitz, W.J., Arneson, L.A. 2012, Stream Stability at Highway Structures, [Hydraulic Engineering Circular No. 20](#), FHWA-HIF-12-004. Federal Highway Administration (FHWA), U.S. Department of Transportation, Washington, D.C.
7. Pierce, Gary J. Wetland Training Institute. 1993. Planning Hydrology for Constructed Wetlands.
8. Richardson, E.V., Simons, D.B., Lagasse, P.F. 2001, River Engineering for Highway Encroachments, [Hydraulic Design Series No. 6](#), FHWA-NHI-01-004. Federal Highway Administration (FHWA), U.S. Department of Transportation, Washington, D.C.
9. Rosgen, Dave. October 1996. Applied River morphology, 2nd Edition.
10. The Federal Interagency Stream Restoration Working Group (FISRWG). 2001. [Stream Corridor Restoration - Principles, Processes and Practices](#).
11. United States Army Corps of Engineers (USACE). 1987. [Corps of Engineers Wetland Delineation Manual](#). Wetlands Research Program Technical Report Y-87-1. Waterways Experiment Station.
12. United States Army Corps of Engineers (USACE). 2001. [Hydraulic Design of Stream Restoration Projects](#). Engineering Research and Development Center. Publication No. ERDC/CHL TR-01-28.
13. United States Department of Agriculture (USDA). Natural Resources Conservation Service (NRCS). 2007. National Engineering Handbook (NEH) [Part 654 - Stream Restoration Design](#).

Chapter 12. Requirements for Hydraulic Design Studies - Contents

Chapter 12. Requirements for Hydraulic Design Studies - Contents	12-i
12.1 Design Criteria	12-1
12.1.1 Design Frequencies and Freeboards	12-1
12.1.2 Discharge Determination	12-4
12.1.3 Flood Stages	12-5
12.1.4 Backwater.....	12-5
12.1.5 Flow Velocities	12-6
12.1.6 Bridge Scour.....	12-6
12.1.7 Bridge Abutment Protection	12-7
12.1.8 Guide Banks (Spur Dikes)	12-7
12.1.9 Detour Structures	12-8
12.1.10 Non-vehicular (Pedestrian) Bridge Structures	12-9
12.1.11 Longitudinal Roadway Encroachments	12-9
12.1.12 Hydraulic Modeling Floodplain Constrictions/Obstructions and Abnormal Flood Stage Conditions	12-10
12.2 Design Data Required	12-11
12.2.1 Required Data from Project Manager.....	12-11
12.2.2 Reference Publications for Design Guidance.....	12-12
12.2.3 Maps.....	12-12
12.2.4 Other Plans, Reports, and Miscellaneous Data	12-13
12.2.5 Regulations and Design Guides	12-13
12.2.6 GDOT Acceptable Computer Models.....	12-13
12.2.7 The Internet.....	12-13
12.3 Design Methods/Procedures – Hydraulic and Hydrological Studies.....	12-14
12.3.1 Methods/Procedures – All Riverine Bridge Projects.....	12-14
12.3.2 Contents of Riverine Hydraulic and Hydrologic Study.....	12-25
12.3.3 Methods/Procedures – All Tidal Projects	12-25
12.3.4 Contents of Tidal Hydraulic and Hydrological Study	12-29
12.3.5 Methods/Procedures – All Riverine Major Culvert Projects.....	12-29
12.3.6 Contents of Riverine Hydraulic and Hydrological Major Culvert Study.....	12-36
12.3.7 Hydraulic and Hydrologic Study Procedures/Design Office and Consultant Responsibilities	12-36
Chapter 12 References.....	12-44

Chapter 12. Requirements for Hydraulic Design Studies

Hydraulic and Hydrologic Requirements for Bridges and Selected Culvert Sites

12.1 Design Criteria

All drainage structures will be designed to minimize flood hazards, to preserve the ecological systems of wetlands, and to pass flood flows across the right-of-way with due consideration given to the risk to the facility, structures in the floodplain affected by the facility, and to the traveling public. Floodplains are the low areas bordering a stream that are subject to inundation by floods and the term is used in this chapter generally and to refer to specific flood boundaries such as the 100-year floodplain. This chapter provides hydraulic design criteria for all existing and/or proposed river and tidal bridge sites and for culverts that meet any of the following conditions:

- For existing or proposed culverts that have a total span length along the roadway of 20 feet or more
- For all sites located on streams where the 100-year floodplain has been delineated on FEMA maps
- For all sites located on streams that are named on county and/or USGS maps
- For all sites that have a significant risk associated with the project such as existing or potential flooding problems
- For all sites that are affected by downstream constrictions, obstructions, or abnormal flood stages from another stream

Study requirements for these major culverts are provided in sections 12.3.5 and 12.3.6.

12.1.1 Design Frequencies and Freeboards

Note: Unless otherwise specified, freeboard refers to the vertical clearance between the bridge superstructure at its lowest point, and the flood stage elevation. Freeboard requirements will not apply to bridge culverts. However, bridge culverts will be subjected to allowable headwater requirements as outlined in chapter 8, section 8.2.3 of this manual.

Riverine Bridge Replacements / New Locations

All bridges will be sized to convey the design flood and base flood (100-year) without causing significant damage to the highway, the stream, or other property. The design flood will be conveyed only through the bridge opening, while any floods greater than the design flood may be conveyed over the roadway and through the bridge opening.

Approval of a design variance by the Office of Design Policy & Support is required when roads designated as state routes for riverine locations do not meet the subgrade and roadway freeboard requirements during a design flood event for a bridge, bridge culvert, or culvert.

1. Interstate

- a. The design flood is the 50-year frequency storm discharge.
- b. A minimum of 2 feet of freeboard above the design flood stage is required.

- c. A minimum of 1 foot of freeboard above the 100-year flood stage is required.

2. Roads Designated As State Routes

- a. The design flood is the 50-year frequency storm discharge.
- b. A minimum of 2 feet of freeboard above the design flood stage is required.
- c. A minimum of 1 foot of freeboard above the 100-year flood stage is required.

3. Roads Not Designated As State Routes

- a. The design flood will be based on average daily traffic (ADT) as follows:

Design Traffic (ADT) Frequency	Minimum Design Storm
0 - 100	5-Year
100 – 399	10-Year
400 – 1,500	25-Year
Over 1,500	50-Year

- b. A minimum of 2 feet of freeboard above the design flood stage is required.
- c. A measure of one-half foot of freeboard above the 100-year (base) flood is desirable.
- d. A minimum of 1 foot of freeboard above the roadway overtopping flood stage is required for overtopping storms less than the 100-year storm.

4. Freeboard For Road Subgrades

To protect the pavement, road subgrades should be 1 foot above the design year high water level. For low volume roads not designated as State Routes, the proposed roadway profile can be set so that the design year high water is a minimum of one-half foot below the shoulder point of the roadway if the conditions in items (a) and either (b) or (c) exist:

- a. Design Year Traffic (ADT) is less than 400 vehicles per day (VPD)
- b. Houses and/or buildings are located in the upstream floodplain with a high risk of being flooded by the 100-year storm; and, the raising of the profile grade of the roadway would have an adverse effect on the potential flooding of these structures
- c. Raising the profile grade elevation of the roadway above this point would increase the 100-year flood backwater above one foot.

5. Additional Design Frequency And Freeboard Considerations

- a. The design storm may require for the roadway to be overtopped with interruptions to traffic due to a low roadway profile. In this circumstance, the design storm can have a more frequent recurrence interval with a lower storm intensity. This design storm must be approved by the GDOT bridge hydraulics engineer.

- b. If the bridge site is affected by abnormal flood stages, the bridge will provide freeboard above the abnormal flood stage and be designed for the velocity that occurs without the effects of the abnormal flood stage.
- c. When haunched girders are used, freeboard will be measured at the haunch location on the bridge.
- d. If the bridge is over a major lake or reservoir where there is boat traffic, the desirable grade should be set so that there is at least 8 feet of freeboard above the maximum operating pool. The minimum grade should not reduce the freeboard from the existing conditions and can be used if this freeboard meets the above-required minimum clearances and satisfies any requirements concerning boat traffic in the area.
- e. If debris is a problem at the site, the above-required minimum clearances may be increased with the concurrence of the GDOT bridge hydraulics engineer.
- f. If the bridge is located over a U.S. Coast Guard navigation channel, the proposed bridge is to be designed to meet the vertical and horizontal clearances as required by the U.S. Coast Guard.
- g. Since Type I Mod beams are often substituted for reinforced concrete deck girders in the final structural design phase, the initial minimum profile grade for these bridges should be set so that the minimum vertical clearances are obtained using the Type I Mod superstructure.

Tidal Bridge Replacements/New Locations

Tidal bridges are designed for unsteady flow conditions during the complete rise and fall cycle of a hurricane or Nor'easter tidal surge. Bridges on tidal streams will be designed to protect the bridge structure itself. Most of the surrounding land and the approach roadways will be inundated by relatively frequent (10- to 25-year) tidal storm surges. The finished grade of the bridge will be set by considering navigational clearances, the approach roadways, topography, and practical engineering judgment.

Approval of a design variance by the Office of Design Policy & Support is required when roads designated as state routes for tidal locations do not meet the subgrade and roadway freeboard requirements during a design flood event for a bridge, bridge culvert, or culvert.

1. Interstate

- a. The design flood is the 50-year storm tide.
- b. One foot of freeboard above the 100-year storm tide is required.
- c. A minimum of two feet of freeboard above the 50-year storm tide is required.

2. Roads Designated As State Routes

- a. The desirable design flood is the 25-year storm tide.
- b. The minimum design flood is the overtopping storm tide, if less than the 25-year storm tide.
- c. A minimum of 2 feet of freeboard above the design storm tide is required.

3. Roads Not Designated As State Routes

- a. No design storm tide is specified.
- b. Two feet of freeboard above the mean high spring tide elevation is required.
- c. A minimum of 2 feet of freeboard above the roadway overtopping flood stage is required for overtopping storms less than or equal to the 10-year storm tide.

4. Freeboard For Road Subgrades

- a. Interstate subgrades should be a minimum of 1 foot above the 50-year storm tide.
- b. One foot above the 25-year storm tide elevation is desirable for state route subgrades. Adjoining roadway elevations can be taken into account when setting minimum roadway grades.
- c. For roads not designated as state routes, road subgrades should be a minimum of 1 foot above the mean high spring tide elevation.

5. Additional Design Frequency and Freeboard Considerations

- a. The design storm may require on occasion for the roadway to be overtopped with interruptions to traffic due to a low roadway profile. In this circumstance, the design storm can have a more frequent recurrence interval with a lower storm intensity. This design storm must be approved by the GDOT bridge hydraulics engineer.
- b. At sites that have a combination of riverine and tidal flows, the various combinations of flows should be analyzed to determine the controlling flow.

Bridge Widening and Parallelings

1. New bridges built parallel to existing structures should follow the design criteria for bridge replacements.
2. The guidelines for widened bridges are outlined below:
 - a. It is desirable for widened bridges to follow the design criteria for bridge replacements.
 - b. At a minimum, the bottom elevation of the widened superstructure shall approximate the existing bottom of superstructure elevation, thereby not reducing the existing area of bridge opening. This minimum design is only considered if no scour or flooding problems exist and the potential for any significant problems seems low.

12.1.2 Discharge Determination

1. For rural drainage basins, use USGS publication, *Magnitude and Frequency of Rural Floods in the Southeastern United States, 2006; Volume 1, Georgia* ⁽¹²⁻⁷⁾ to determine the various storm discharges for the project site. The regional flood frequency relations and applicable gage data should be used as shown in this publication. Updated gage information can also be obtained at <http://waterdata.usgs.gov/ga/nwis/rt>
2. For urban drainage basins, use USGS publication, *Methods for Estimating the Magnitude and Frequency of Floods for Urban and Small, Rural Streams in Georgia, South Carolina, and North Carolina, 2011* ⁽¹²⁻⁶⁾ to determine the various storm discharges at the project site.

3. For sites affected by regulation from dams, reservoirs or other areas of significant storage volume upstream of the project site, the discharge must be determined by routing the various floods through the basin taking into account the storage volume and any outlet structures. Unless the basin is located immediately upstream from the bridge site, the runoff hydrograph for the drainage area between the bridge and basin outlet should be combined with the basin outflow hydrographs to determine the design discharges. For large dams, a stage-discharge curve and historical peak discharges may be obtained from the operators. Refer to chapter 4 of this manual regarding flood hydrograph development for storage and routing.
4. For tidal areas, the storm discharges are determined by an approved tidal computer model (see section 12.3.3 of this manual) using the downstream boundary conditions (typically stage vs. time storm surge hydrographs) along with the applicable upland riverine discharge.

12.1.3 Flood Stages

1. When a USGS gage is located at or near the bridge site, flood stages to calibrate the computer model can be obtained from the USGS regional office in Atlanta or <http://ga.water.usgs.gov/>. In addition, if in the engineer's judgment, reliable high water information at or near the site is available and the flood frequency of the applicable storm can be determined, the computer model can be calibrated using this information.
2. For sites where reliable flood stage information is not available, the applicable computer model should be used to determine the various flood stages at the project site.

12.1.4 Backwater

Backwater is measured relative to the natural water surface elevation without the effect of the bridge at the approach cross section.

Note: The U.S. Army Corps of Engineers Hydrologic Engineering Center has conducted research concerning the location of the approach and exit sections in the hydraulic computer model. The conclusions and recommendations from this study are contained in the HEC-RAS Hydraulic Reference Manual, ⁽¹²⁻¹³⁾ [appendix B](#), *Flow Transitions in Bridge Backwater Analysis*, and should be used in determining the locations of the approach and exit sections in the HEC-RAS or WSPRO computer models.

1. The 100-year backwater should be limited to 1 foot above the unrestricted or natural 100-year water surface profile.

Note: This backwater value shall include effects from the **proposed roadway in the case of a longitudinal encroachment on the floodplain.**

2. The engineer may determine that the above limitation in requirement 1 is not practical for bridge replacement projects. In this case, the 100-year backwater elevation may exceed 1 foot above the unrestricted or natural 100-year water surface profile, but it may not be higher than the existing condition backwater value.
3. **Note:** This limitation will only be accepted for new drainage structures in rare instances where it can clearly be shown that it is impractical to size the drainage structure for the

above limitation in requirement 1. The waiver of the above limitation in requirement 1 necessitates the approval of GDOT's hydraulic engineer.

Note: Example conditions where the limitation in section 12.1.4 requirement 1 would be waived are as follows:

Due to shallow flow in the overbank area where additional span lengths and/or overflow structures do not significantly reduce the velocity and backwater values; and where the existing structure creates a significant amount of backwater and storage upstream of the roadway and sizing the proposed structure to meet requirement 1 would adversely affect downstream development.

Justification for the waiving of section 12.1.4 requirement 1 must be clearly shown in the hydraulic and hydrological study. In all cases, the drainage structure must be sized so that the drainage structure and roadway are protected against failure during major flood events.

4. For bridge widening and paralleling projects, the existing backwater may already be in excess of 1 foot over the unrestricted or natural 100-year water surface profile. If there are no existing scour or flooding issues, the existing backwater would be considered acceptable. The guidelines contained in section 12.3.1, paragraph 8.b, *Bridge Widening and Paralleling*, shall be followed to minimize increases in backwater due to the proposed construction.
5. In addition to the above limitations, bridges located within areas covered by a FEMA regulatory floodway will be sized to satisfy FEMA requirements. See chapter 2 of this manual, *Agency Coordination and Regulations*.
6. Future development, current conditions, and past historical flooding conditions in the upstream and downstream floodplains should be considered for all cases.

12.1.5 Flow Velocities

Flow velocities within the bridge opening should be limited to minimize scour in the overbank portion of the opening. Acceptable stream channel and overbank velocities should be determined by comparison with the natural velocities and existing bridge velocities, along with any scour problems, or lack thereof, at the existing structure. The type of soil at the site (highly erodible or not) should be considered. Box culverts should be sized with acceptable flow velocities to minimize potential scour.

Note: As a general rule to minimize scour, the maximum desirable stream channel velocity values for new bridges should be in the range of 1.5 to 1.75 times the natural/unrestricted channel velocity for the design year and 100-year storms.

12.1.6 Bridge Scour

A scour analysis should be performed for all bridges, using the methods in the latest version of the FHWA HEC-18, [\(12-2\) Evaluating Scour at Bridges](#). General contraction and local (pier) scour calculations should also be performed. The design flood for scour is the 100-year flood or the overtopping flood if it is less than or equal to the 100-year flood. Scour should also be computed for

the 500-year flood or the overtopping flood if it is greater than the 100-year flood and less than the 500-year flood.

Note: The theoretical scour depths for the proposed bridge(s) are normally performed without the benefit of a bridge foundation investigation for the proposed structure. The median grain diameters (D_{50}) of sand that are normally used by GDOT in the FHWA scour equations to estimate the theoretical scour depths are as follows:

Very Coarse Sand:	$D_{50} = 0.00492$ ft
Coarse Sand:	$D_{50} = 0.00246$ ft
Medium Sand:	$D_{50} = 0.00123$ ft
Fine Sand:	$D_{50} = 0.00062$ ft
Very Fine Sand:	$D_{50} = 0.00031$ ft

The hydraulic engineer should search the existing bridge files for old bridge foundation investigations or other information that would assist in deciding which D_{50} would be appropriate for the site. Soil information at nearby crossings along the same stream can also be helpful in this regard.

The predicted scour depths at each intermediate bent of the proposed bridge should be provided to the Office of Materials Soils Lab. The soils engineer should adjust, if necessary, the predicted scour depths depending on the soil conditions at the site. As part of the bridge foundation investigation, the soils engineer should provide the final predicted scour depths to the bridge structural engineer for inclusion in the analysis and design of the bridge foundations.

12.1.7 Bridge Abutment Protection

Spill-through type abutment endrolls with a 2:1 slope normal to the end bent are normally used for new bridges. Riprap protection for these endrolls should be sized using the method shown in the latest version of the FHWA HEC-23, [\(12-9\)](#) *Bridge Scour and Stream Instability Countermeasures*. The 100-year flood should be used for this design. This riprap protection should be entrenched 2 feet below the ground line and extend 2 feet above the 100-year flood stage elevation. The riprap protection should be extended a minimum distance of 20 feet beyond the end of the abutments. A riprap apron with a width equal to twice the 100-year storm flow depth in the overbank area from a minimum width of 8 feet to a maximum of 25 feet should be used to protect the endroll toes. The riprap apron should not extend beyond the top of the stream channel bank. The depth of the riprap at the endrolls is normally 2 feet. The Department of Transportation uses two sizes of riprap: Type 1 riprap has a D_{50} of 1.14 feet and Type 3 riprap has a D_{50} of 0.64 feet. Woven plastic filter fabric is placed under the riprap (refer to GDOT Specification 881.2.05).

Note: Type 1 riprap should be used at all locations. Type 3 riprap may be substituted where placement problems prevent the practical use of Type 1 riprap **AND** it is shown that Type 3 riprap is sufficient protection against scour damage during the 100-year flood.

12.1.8 Guide Banks (Spur Dikes)

Guide bank calculations should be performed as shown in the latest version of the FHWA HEC-23, [\(12-9\)](#) *Bridge Scour and Stream Instability Countermeasures* and will be based on the 100-year

flood. Guide banks are not required to be built where the calculated length is less than 150 feet. Based on FHWA practice, GDOT recommends a maximum length guide bank of 150 feet be built where the calculated length is 150 feet or more. The design engineer, with concurrence from the GDOT bridge hydraulics engineer, may specify a longer or shorter guide bank be built or that no guide bank be built. The reasons supporting these options should be included in the hydraulic and hydrological report.

Note: As a general rule, it is desirable to size new bridges so that guide banks will not be required. This can be accomplished by extending the new bridge to the wide side of the floodplain and/or the addition of overflow structures.

12.1.9 Detour Structures

1. Where detour structures are required, they need to be sized to maintain traffic during the new construction. The detour structure may be a bridge, extension of a proposed culvert, or corrugated metal pipes. The detour structure is sized to convey the 10-year storm, and is recommended to be placed downstream of the proposed bridge site. The detour bridge superstructure shall clear the 10-year flood stage elevation. In certain cases, traffic can also be maintained by staged construction of the proposed bridge.

Note: The detour structure shall be sized to convey and clear the 2-year storm on local roads not designated as state routes that have a design year ADT less than 400 VPD.

2. Detour structures in tidal areas are to be sized based on the recommendation of the GDOT hydraulics engineer. The minimum size should be based on the high tide flow conditions.

General Guidelines for Sizing Detour Bridges:

- a. The detour bridge and roadway are sized to safely convey the 10-year storm (or smaller, if applicable), while remaining open to traffic. Engineering judgment must be used when determining acceptable flow velocity and backwater values for the detour structure. Development in the upstream floodplain should be considered in all cases.
- b. Since the detour structure is sized to convey a smaller storm than the adjacent highway bridge, the detour structure should be placed downstream of the roadway bridge unless conditions warrant otherwise. These conditions include but are not limited to adverse downstream channel geometry, conflicts with utilities, conflicts with houses, buildings or other structures, and wetland or other environmental issues.
- c. It is assumed that the detour bridge will be centered about the stream channel and/or aligned with the existing bridge opening.
- d. It is assumed that the normal depth of the superstructure for a detour bridge will be approximately 2 feet.
- e. The freeboard should be set as 1 foot of clearance between the bridge superstructure and the 10-year flood stage, or smaller storm as applicable.
- f. Although it is assumed the detour bridge will be placed as low as possible in order to minimize bridge length, the hydraulic engineer should check with the road designer to confirm the profile grade for the detour alignment. Due to roadway geometrics, the roadway

designer may not be able to lower the detour grade so that the minimum length bridge can be used.

- g. A detour bridge that is longer than the existing or proposed highway bridge is unusual, but possible if a valid reason is provided.

12.1.10 Non-vehicular (Pedestrian) Bridge Structures

1. For non-vehicular (pedestrian) bridges, the designer should provide a copy of the hydraulic study along with the preliminary bridge plans to the Department addressing each of the following items. This study must be signed and stamped by the registered professional engineer who prepared the study.
 - a. The hydraulic and hydrological study should meet the applicable guidelines and recommendations in chapters 2 and 12 of this manual.
 - b. The study should include a theoretical scour analysis for the 100-year and 500-year flood frequency.
 - c. For sites located within a regulatory floodway, the proposed bridge should be sized to obtain a no-rise certification. Coordination with the community is required and a copy of the community's letter of concurrence must be included in the study. If a no-rise certification cannot be obtained, coordination with the community and with FEMA is required. Include a copy of the community's letter of concurrence and a copy of the approved Conditional Letter of Map Revision (CLOMR) in the study.
 - d. Backwater for the 100-year storm is not to exceed 1 foot above the natural conditions.
 - 1) The minimum design year storm for pedestrian bridges is the 25-year storm for drainage areas less than 100 square miles. For drainage areas greater than 100 square miles, the design storm is the 50-year storm.
 - 2) It is preferred to have 1 foot or more of clearance above the design storm. However, a minimum of one-half foot is required.
2. For a pedestrian bridge located adjacent to a highway bridge, the pedestrian bridge will be designed so that the hydraulic opening is equivalent or larger than the adjacent highway bridge. In addition, any intermediate pedestrian bridge bents will be placed to line up with the existing intermediate highway bridge bents. If the pedestrian bridge meets the criteria of section 12.1.10 requirement 2 and is not located within a regulatory floodway, a hydraulic and hydrologic study is not required. In all other cases, a study must be performed and submitted with the plans.
3. Pedestrian trails located entirely on boardwalks and having no fill within the limits of the floodplain are not considered bridges. A hydraulic study will not be required for these situations.

12.1.11 Longitudinal Roadway Encroachments

Since longitudinal encroachments into the base floodplain (100-year floodplain) and floodway by new and widened roadways have a major effect on the flood elevations of the affected stream,

these encroachments should be avoided if possible. The project manager and location engineer should use the following basic rules for roadway widenings, parallelings, and new locations:

1. For roadway widening projects, the typical section should be set to avoid or minimize the placing of additional roadway fill within the adjacent base floodplain.
2. For roadway paralleling projects, the new parallel roadway should be placed to avoid or minimize longitudinal encroachments on the base floodplains.
3. New location roadway projects should be aligned to avoid or minimize longitudinal encroachments on base floodplains.
4. **For all cases**, longitudinal encroachment on a delineated FEMA regulatory floodway shall be avoided if at all possible.

The computer model should show the effects of any longitudinal encroachment of the proposed project on the base floodplain.

12.1.12 Hydraulic Modeling Floodplain Constrictions/Obstructions and Abnormal Flood Stage Conditions

Effects from natural or man-made conditions may affect the flood stages at the crossing site. These effects must be taken into account when modeling and analyzing the hydraulic conditions at the project site. The hydraulic engineer must identify and include any of these conditions that will affect the project site in the hydraulic model. Following are some examples:

- Roadway and railroad stream crossings
- Longitudinal roadway encroachments, see section 12.1.10 of this manual
- Natural narrowing of the floodplain
- Fill that has been placed within the floodplain
- Reservoirs, dams, and levee structures
- Confluence with another stream (all above items must be taken into account when modeling this stream)

Normal Water Surface Profile Run. This computer run includes any floodplain constriction or obstruction that controls or affects the flood stages at the project site with the normal storm flows along the stream reach. This computer run is the basic run in all hydraulic studies.

Abnormal Flood Stage Run. This computer run includes any backwater effects from a natural or man-made condition that causes flood stages at the project crossing that are not due only to the normal storm flows along the stream reach. For example, an abnormal flood stage may result when the studied stream is a tributary to another river or stream, and the flood flows along this river or stream cause flood stage elevations to rise at the project site.

A reservoir that affects the flood stages at the project site can be considered a normal or abnormal flood stage condition depending on the situation. If the flood stages at the project site are controlled at all times by the reservoir, this is considered a normal flood condition. If the flood stages at the project site are only controlled a portion of the time by the reservoir, then this would be considered an abnormal flood stage condition.

If the proposed bridge site is affected by abnormal flood stages that result in higher flood stages and lower flood flow velocities than a normal flood condition, the bridge is to be designed to provide the required freeboard above the abnormal flood stage elevations. In addition, the bridge is also to be designed for the higher storm flow velocities that occur without the effects of the abnormal flood stages.

12.2 Design Data Required

12.2.1 Required Data from Project Manager

1. Three sets of preliminary proposed roadway plans. These plans are to include, but are not limited to, the following information:
 - a. A cover sheet with the project number, PI number, route number, traffic data, and location map
 - b. Typical sections at bridges and roadways
 - c. Plan and profile sheets should depict the floodplain limits. The plan and profile sheets should include the following information:
 - Proposed profile grade data with vertical curve data, complete with point of vertical intersection (PVI) stations, elevations, grades and vertical curve lengths
 - Bearing along tangent section of the construction centerline
 - Horizontal curve data complete with point of intersection (PI) station and maximum superelevation rate
 - Transition stations from normal crown section to full superelevation section
 - Location of existing bridge(s) and roadway; begin and end bridge stations
 - Benchmark information; location of benchmarks in stations and offsets; physical description of benchmarks; benchmark elevation; benchmark datum. The benchmark datum should be in the project datum. The project datum is normally NGVD-29 or NAVD-88. The National Geodetic Survey (NGS) <http://www.ngs.noaa.gov/> provides conversion information between vertical datums based on the latitude and longitude of the site. The engineering manager/operations of the Office of Environmental Services of GDOT should be contacted for conversion information from NGVD29 to NAVD88. The NGS also provides information on tidal benchmarks and conversions between tidal datums (e.g., mean low water) and fixed vertical datums (NGVD29 and NAVD88).
 - Three benchmarks are required. One at the beginning of the survey, one at the bridge or stream site, and one at the end of the survey. For bridges that exceed 400 feet in length, a benchmark near both ends of the structure should be provided. The benchmarks near the bridge should be located within 300 feet of the bridge ends.
 - Plot of stream traverse on plan sheet

2. A copy of the hydraulic engineering field report. For a template copy or an example copy of the hydraulic engineering field report, refer to the latest GDOT Survey Manual.
3. InRoads/CAiCE survey files for the project. These files should include all data that is specified on the hydraulic engineering field report. This field report contains a detailed listing of the minimum survey data that is required. Also, the proposed construction centerline information should be entered into the InRoads/CAiCE file by the project manager.
4. For new location projects, a copy of a USGS quadrangle map with the project alignment accurately located.

12.2.2 Reference Publications for Design Guidance

1. FHWA HEC-18, [\(12-2\)](#) *Evaluating Scour at Bridges*
2. FHWA HEC-20, [\(12-10\)](#) *Stream Stability at Highway Structures*
3. FHWA HEC-23, [\(12-9\)](#) *Bridge Scour and Stream Instability Countermeasures*
4. FHWA HEC-25, [\(12-5\)](#) *Tidal Hydrology, Hydraulics and Scour at Bridges*
5. USGS Scientific Investigations Report 2009-5043, *Magnitude and Frequency of Rural Floods in the Southeastern United States, 2006; Volume 1, Georgia* [\(12-7\)](#)
6. USGS Scientific Investigations Report 2014-5030, *Methods for Estimating the Magnitude and Frequency of Floods for Urban and Small, Rural Streams in Georgia, South Carolina, and North Carolina, 2011* [\(12-6\)](#)
7. USGS Water-Resources Data Georgia Water Year
8. The users manuals for the respective computer models
9. FEMA Flood Insurance Studies
10. FHWA *Hydraulics of Bridge Waterways* [\(12-4\)](#)
11. NOAA Technical Memorandum, NWS Hydro-19, *Storm Tide Frequency Analysis for the Coast of Georgia* [\(12-8\)](#)
12. USGS Open-File Report (updated annually), *Annual Peak Discharges and Stages for Gaging Stations in Georgia*
13. NOAA Tide Tables (updated annually), *East Coast of North and South America, including Greenland*
14. U.S. Army Corps of Engineers, *Shore Protection Manual* [\(12-12\)](#)

12.2.3 Maps

1. USGS contour maps
2. County maps
3. Bathymetric maps

12.2.4 Other Plans, Reports, and Miscellaneous Data

1. The existing bridge and roadway plans
2. The project concept report
3. The bridge maintenance file for the existing structure
4. Previous hydraulic studies done by GDOT, U.S. Army Corps of Engineers, FEMA and the USGS
5. Aerial photos
6. For bridge widenings and parallelings only:
 - a. Bridge deck condition survey from the State Materials Concrete Branch
 - b. Bridge condition survey from the State Bridge Maintenance Office

Note: Sample letters requesting the bridge deck condition survey and the bridge condition survey are included in [appendix I](#) of this manual.

12.2.5 Regulations and Design Guides

1. Geometric Design Guides 4265-2, 4265-9, and 4265-10. The proposed bridge widths are to be determined using these design guides.
2. Federal-Aid Policy Guide, NS 23 CFR 650A, *Procedures for Coordinating Highway Encroachments on Floodplains with Federal Emergency Management Agency (FEMA)*. See chapter 2 of this manual.

12.2.6 GDOT Acceptable Computer Models

1. HEC-RAS (USACE)
2. WSPRO (FHWA)
3. UNET (USACE)
4. FESWMS (FHWA)
5. RMA-2V (USACE)
6. SRH-2D (USBR)
7. HY-8 (FHWA)

12.2.7 The Internet

Note: The Internet is an important tool that should be used for gathering information that previously was available only through publications or various agencies. The USGS, FEMA, the USACE, NOAA, TVA and the FHWA are among the agencies that have internet web sites. Internet sites, in many cases, will have the most updated information that can be used in the performance of hydraulic and hydrological studies.

Information, data, and publications from the above agencies may be found at the following websites:

1. USGS: <http://pubs.er.usgs.gov/>
2. FEMA: <http://www.fema.gov/national-flood-insurance-program/national-flood-insurance-program-publications>
3. USACE: <http://publications.usace.army.mil/publications/>
4. NOAA: <http://www.lib.noaa.gov/noaainfo/pubsources.html>
5. TVA: <http://www.tva.com/river/index.htm>
6. FHWA: http://www.fhwa.dot.gov/engineering/hydraulics/library_listing.cfm?archived=true

12.3 Design Methods/Procedures – Hydraulic and Hydrological Studies

12.3.1 Methods/Procedures – All Riverine Bridge Projects

Note: The following methods/procedures are for bridge requirements, new locations, widening, and parallelings unless otherwise noted.

1. The following hydraulic computer models are approved by GDOT to be used when tidal flow is not present:
 - a. USACE computer model HEC-RAS. The WSPRO bridge routine is the preferred option for bridge hydraulic analyses. One of the other bridge options may be more appropriate for specific site conditions and can be used. The HEC-RAS Hydraulic Reference Manual provides guidance on selecting a bridge modeling approach for specific site conditions.
 - b. FHWA computer model WSPRO.
 - c. The Finite Element Surface Water Modeling System (FESWMS) or the Sedimentation and River Hydraulics (SRH-2D) two-dimensional computer models. These models can be used in cases where there is a large amount of two-dimensional flow and the hydraulic engineer considers the WSPRO and/or HEC-RAS computer models to be inadequate for the conditions. Cases where these programs can be used include a skewed crossing of a wide floodplain, a wide floodplain requiring multiple bridges, very wide floodplains, or if there is significant lateral flow in the vicinity of the bridge, such as close proximity to a meander bend, or a stream junction immediately upstream.
 - d. USACE computer model RMA-2V. This two-dimensional computer model can be used in lieu of FESWMS for the floodplain conditions listed in item (c) above.
 - e. If the drainage area contains significant storage volume upstream of the project site, the runoff must be determined by developing unit hydrographs, routing the various floods through the basin, and taking into account the storage.

Note: The USACE computer model UNET is a one-dimensional unsteady flow model with the capabilities of flood routing and storage calculations. The UNET unsteady flow routines are contained in the HEC-RAS model;
 - f. For bridge sites with a drainage area of 20 square miles or less, a box culvert alternate must be considered. Two culvert computer models are accepted: (1) The FHWA HY-8

computer model for box culverts is to be used in conjunction with the results from the WSPRO computer model; and (2) The HEC-RAS computer model.

- g. For regulatory FEMA hydraulic models produced from the USACE software HEC-2, HEC-RAS will be used to duplicate the current regulatory FEMA hydraulic model from HEC-2 to produce the floodway and profile runs.

Note: The HEC-RAS computer model with the WSPRO bridge routine, or the WSPRO computer model is to be used for the bridge hydraulic analysis unless special floodplain conditions exist which warrant the use of other bridge routines within HEC-RAS or other computer models. Computer models, other than those listed above, may be considered for special floodplain conditions. The use of the two-dimensional hydraulic models FESWMS, SRH-2D or RMA-2V requires the approval of the DOT bridge hydraulics engineer.

2. Investigate the flood history of the stream. Sources for this information include, but are not limited to the following:
 - a. USGS gage records
 - b. Existing bridge and maintenance files
 - c. Previous studies done by the DOT, USACE, FEMA, and the USGS
 - d. Information from local residents
 - e. Information from the local government
 - f. Information from local GDOT personnel
 - g. Hydraulic engineering field report
3. Investigate the bridge site scour history. The following are some sources of information:
 - a. Bridge inspection and maintenance files.
 - b. Comparison of the original bridge plan and profile with the currently surveyed profile.
 - c. Aerial photographs taken over as long a time span as available. Based on this information, an indication of the long-term channel stability and aggradation or degradation can be estimated. An evaluation of the performance of the existing bridges can also be made.
 - d. For bridge widenings and parallelings only: A bridge condition survey for the existing bridge shall be requested from the Office of Bridge Maintenance, along with a bridge deck condition survey from the Office of Materials Concrete Branch (Forest Park Lab). These surveys will recommend any needed repairs to the existing bridge, or if the repairs are extensive, will recommend the replacement of the existing structure. These recommendations are to be incorporated into the preliminary bridge layout and study.
4. Determine the project site hydrology for the bridge.
 - a. Use USGS topographical data or GIS spatial data to determine the drainage basin area for the project site. Determine the land usage from aerial photography, topographic maps, or the USGS Land Cover Institute (LCI) spatial data website

<http://landcover.usgs.gov/landcoverdata.php>. A site visit will be required to confirm land use information.

- b. Determine the discharges at the project site for the various storm frequencies. Refer to section 4.1.1.1 for the appropriate method.
 - c. Estimate the average hydraulic slope at the site using USGS topographical, survey, or GIS spatial terrain data (i.e., LiDAR data).
 - d. Estimate the Manning's n values for the stream channel and floodplain areas for the project site. Manning's n values should be determined from the results of the site inspection and compared with the table values and photographs from the following publications:
 - FHWA, *Hydraulics of Bridge Waterways*, March 1978 (12-4)
 - USGS Water Supply Paper 1849, *Roughness Characteristics of Natural Channels* (12-3)
 - USGS Water Supply Paper 2339, *Guide for Selecting Manning's Roughness Coefficients for Natural Channels and Flood Plains* (12-1)
5. Field Inspection of the project site.

The hydraulic engineer performing the study and computer modeling should perform a site visit and inspection of the bridge site(s). During the field inspection, the engineer should evaluate the following:

- Characteristics and hydraulic properties of the stream
- Performance of the existing bridge (if applicable)
- Channel and floodplain geometrics
- Adequacy and accuracy of the survey data

In addition, the following site conditions should be noted:

- Buildings or structures in the floodplain that may be subject to flooding
- Scour problems at the existing bridge (if applicable)
- Evidence of past channel migration or potential for future migration

During the field inspection, stream crossings immediately upstream or downstream of the project site on the same stream should be visited and the performance of the structures noted.

6. Determine the extent of survey data.

The hydraulic engineer is to determine the extent of survey data required to accurately model the project site based on the requirements from the latest GDOT Survey Manual. Please refer to this manual for the required survey information.

Note: For projects located on a stream where a detailed FEMA study has been performed, channel cross sections from the FEMA study may be used to supplement the project survey data in the development of the project hydraulic model. Care must be taken to review the

FEMA data for completeness and accuracy, since quite a number of the FEMA studies are outdated and sometimes contain questionable input.

7. Hydraulic Analysis

a. The hydraulic computer model is to be used to determine the natural, existing, and proposed conditions at the site. The 2-, 10-, 100-, 500-, and design year or overtopping storm is to be modeled for the project site. The design flood is conveyed through the bridge opening, while floods greater than the design flood **may** be conveyed over the roadway and through the bridge opening. The 2-year flood is modeled for USACE permit purposes. The 10-year storm is used to size the detour structure.

Note: The 2-year storm is used to size the detour structure on local roads not designated as state routes that have a design year ADT less than 400 VPD.

- b. When a USGS gage is located at or near the bridge site, flood stages to calibrate the computer model are to be obtained from the USGS regional office in Atlanta. If reliable highwater information at or near the site is available and the flood frequency of the applicable storm can be determined, the computer model should be calibrated using this information.
- c. If the drainage area is less than 20 square miles, a box culvert alternate should be analyzed. The natural or unrestricted highwater profiles should be developed using WSPRO or HEC-RAS. Two culvert computer models are acceptable: (1) The FHWA HY-8 computer model; and (2) The culvert routine within the HEC-RAS computer model.
- d. For projects with existing and/or proposed multiple bridges/culverts within the same floodplain, the WSPRO or HEC-RAS computer models can be used to size and analyze these drainage structures at crossings where two-dimensional computer models may not be necessary. The culvert analysis provided by WSPRO and HEC-RAS for these multiple drainage structure conditions are acceptable without running the HY-8 computer model.
- e. If the project is within a FEMA regulatory floodway, FEMA guidelines must also be satisfied. See chapter 2, *Agency Coordination and Regulations*.

8. Hydraulic Design of Bridge

a. Bridge Replacements/New Locations

- 1) Establish the orientation of the bridge substructure by determining the flood flow angle. This should be based on topographic maps, aerial photographs, and the site inspection. If FESWMS is used, it will compute the velocity vectors, which will show the flood flow angle directly.
- 2) Spill-through abutment type endrolls with a 2:1 slope normal to the end bent are used for new bridges. The toe of the bridge endrolls should be placed a minimum of 10 feet from the creek bank or at a point 10 feet from where a 2:1 slope from the bottom of the creek bank intersects the groundline in the overbank, whichever is greater.

- 3) In cases where the approaching channel bends before crossing under the bridge, the toes of the bridge endrolls should be placed to avoid direct overbank flow from the channel, if practical.
- 4) If the bridge is located in or near a channel bend, the possibility of stream channel migration is increased. The toes of the bridge endrolls should be placed far enough back so that any channel migration would not reach them during the lifetime of the bridge; 75 years is a minimum lifetime of the bridge. The rate and direction of channel migration can be predicted by comparing historic and recent aerial photography (HEC-20).
- 5) The proposed bridge length shall be set as the minimum length structure which has acceptable backwater and flow velocities as per the guidelines in sections 12.1.4 and 12.1.5 of the design criteria section of this manual.
- 6) The profile grade elevation of the bridge shall be set so that the proposed bridge superstructure will meet the clearance requirements specified in section 12.1.1 of this manual while keeping the proposed profile as close to the existing profile as possible. The profile grade along the centerline of the proposed bridge should be set so that the bridge will drain surface flow. Avoid flat grades and the placement of the low point of a vertical curve on a bridge or approach slab.
- 7) The profile grade along the proposed roadway shall be set to meet the requirements as specified in section 12.1.1.
- 8) Set the span lengths for the bridge. The span over the channel should be set first. If practical, the channel should be completely spanned. The substructure should be offset far enough from the channel banks so that the banks will not be impacted during construction. For concrete intermediate bents, this means that a minimum clearance of 10 feet should be maintained from the top of bank to the centerline of the bent. For pile bents, a minimum of 5 feet of clearance should be maintained from the top of bank to the centerline of the bent.
- 9) At sites where the bridge bent heights are acceptable and subsurface conditions are suitable, pile bents are typically used. A reinforced concrete deck girder superstructure with spans from 26 feet to 40 feet at two foot intervals is used with this substructure.
- 10) At sites where the bridge bents are too high for the pile substructure, where the subsurface conditions warrant, where there is a debris problem, or where a long span is required, concrete intermediate bents with footings are typically used. Spans longer than 50 feet normally use cast-in-place concrete bents. If PSC (prestressed concrete) pile bents are anticipated, pile bents can be used for spans up to 70 feet in length.
- 11) Where intermediate bents must be located within the stream channel, they should be aligned with the stream channel flow. Tower bents should not be located within the stream channel or at the channel banks. Bents required at those locations should be pile bents in order to reduce the potential for pier scour.

12) For ease of structural design and repetition in fabrication, the use of equal span lengths is recommended while following sound hydraulic design practices.

13) Approximate span lengths for prestressed beams are as follows:

Type I Mod	up to 45 ft
Type II	40 to 64 ft
Type III	54 to 86 ft

The above maximum lengths are for 28 day concrete strengths of 6000 psi.

54 in bulb tee	78 to 112 ft
63 in bulb tee	90 to 126 ft
72 in bulb tee	110 to 142 ft

The above maximum lengths are for 28 day concrete strengths of 7000 psi.

Note: The above span lengths are approximate and may be increased moderately by increasing concrete strength.

14) For bridge replacement projects, the existing bridge is removed. The existing bridge substructure is removed as per the specifications. Any existing roadway fill within the proposed bridge opening is removed down to the original/natural groundline. If the new roadway and bridge is along a shifted or new alignment, the existing bridge and roadway fill is removed.

Note: Exceptions to the above existing bridge and roadway removal will be made if the proposed bridge is along a new or shifted alignment and the existing bridge is declared historical; or the county wants to maintain the existing bridge and assume all liability for the structure. Even in these cases, the existing roadway fill may have to be totally or partially removed for hydraulic purposes.

15) For new dual or twin bridges, it is desirable to align the proposed endrolls and intermediate bents. If conditions warrant, the span arrangement for each bridge can be varied to adhere to the recommendations listed in this section.

b. Bridge Widening and Parallelings

- 1) In general, the above recommendations in section 12.3.1, paragraph 1.a for bridge replacements are employed where applicable.
- 2) The first choice for the widening and/or paralleling of an existing bridge is to approximate the existing low chord elevation, span lengths, and bent skew.
- 3) When paralleling an existing bridge, it is desirable to match the existing endrolls and to align the proposed bents with the existing bents.
- 4) Some common complications and solutions are as follows:
 - a) If the bridge widening is significant and the existing bents do not align with the flood and/or channel flow, the widened bents can be skewed to match the flood

and/or channel flow. Similarly, bents for a parallel bridge may also be skewed to match the flood/channel flow.

- b) The span arrangement for the parallel bridge can be varied from the existing bridge to adhere to the recommendations in section 12.3.1. paragraph 8.a.
 - c) If the existing low chord elevation does not provide the required clearance over the design year and 100-year floods and/or the backwater/velocity/scour values indicate that a longer/higher structure is needed, the following steps should be taken:
 - The bridge history should be investigated and maintenance records should be reviewed for any past or existing scour problems at the site. In addition, the hydraulic engineering field report should indicate any existing flooding and/or scour problems. The engineer should perform a site inspection to observe any existing or possible future problems.
 - If no scour or flooding problems exist and the potential for any significant problems seems low, the engineer can opt to widen the structure in-kind with no major changes. The new parallel bridge shall provide the same freeboard as that required of new bridges.
 - If there is evidence of flooding and/or scour problems, if the widening/paralleling is so significant that the calculations indicate that a longer/higher structure(s) is required, or if the existing foundations are inadequate, then the engineer must make the necessary adjustments to the existing structure until it is hydraulically sufficient. These options can include jacking the superstructure of the existing bridge, adding spans to the existing bridge, adding an overflow structure, or replacing the existing structure. A cost comparison shall be included to determine the most cost effective alternative.
- 5) It is desirable for the proposed widened and/or parallel bridge endrolls to clear the creek channel by the minimum distance specified in section 12.3.1, paragraphs 8.a and 8.b. If this clearance cannot be achieved by widening or paralleling in-kind, the following options should be considered:
- a) For a bridge widening, the widened end bent(s) can be skewed away from the stream channel.
 - b) The proposed widened and/or parallel bridge(s) can be lengthened, placing the end bent(s) farther away from the stream channel to obtain this clearance.
- 6) The possibility of replacing the existing bridge with a more cost effective structure should be checked if the following is evident:
- a) The computer model indicates that the existing bridge is oversized.
 - b) Extensive repairs to the existing bridge are required.
 - c) The existing bridge has steel beam superstructure.

- d) The existing bridge has relatively short spans and the widened section requires expensive substructure construction.
- 7) To determine whether the bridge is in good enough condition structurally to be widened, and/or to determine the extent of repairs needed to the existing bridge structure when widening and/or paralleling, the following internal GDOT bridge surveys shall be requested by the project manager before the hydraulic study is requested:
 - a) The GDOT bridge deck condition survey from the State Materials Office Concrete Branch.
 - b) The GDOT bridge condition survey from the State Bridge Maintenance Office.

Sample letters requesting these surveys are included in [appendix I](#) of this manual.

Note: The bridge condition surveys and recommendations should be confirmed with the State Bridge Maintenance Office and/or State Office of Materials if any one of the following statements applies:

- (1) The original bridge condition surveys show that extensive repairs are needed and/or the sufficiency rating for the structure is borderline and the condition surveys are at least 2 years old.
- (2) If an overlay is proposed to be placed on an existing concrete deck for any reason, hydrodemolition of the existing deck may be required for bonding purposes. Confirmation that the existing bridge deck is in good enough condition for this process should be obtained from the above offices.
- (3) The original bridge condition surveys are at least 3 years old for any sufficiency ratings.

c. Box Culvert Alternative

If a box culvert alternative is selected in lieu of a bridge, the box culvert(s) will be placed at sites that have favorable floodplain conditions. Favorable conditions would include a well-defined creek channel and a site that is not likely to accumulate silt or debris in the culvert barrels.

Unless otherwise directed by GDOT, culverts shall not be placed at locations with unfavorable conditions such as swampy areas, sites that are frequently affected by abnormal stage conditions, sites where beaver dams are prevalent, or sites that historically have had large amounts of debris in the stream channel.

General design considerations for using a box culvert alternative are as follows:

- Culvert width is set by matching the width of the stream channel.
- Design the inlet to be inundated for the design year and 100-year storms.
- Culvert height shall be set to follow the guidelines of chapter 8 for fish passage.
- The culvert shall be sized to provide acceptable flow velocities and backwater values.

- GDOT standard sizes and skews for box culverts shall be used. Standard culvert sizes range from a single barrel 4 ft wide by 4 ft high box to a five barrel 10 ft wide by 12 ft high box. Standard skews are 45, 60, 75 and 90 degrees.
- Acceptable outlet velocities shall be determined by comparison with the natural channel velocities and existing drainage structure velocities.
- Evaluate scour based on section 12.3.1, paragraph 9.
- The type of soil at the site (highly erodible or not) shall be considered.
- A cost comparison between using a box culvert versus a bridge shall be performed to support the final hydraulic structure selection.

Environmental considerations may preclude construction of a box culvert. As a result, documentation from the Office of Environmental Services is required.

9. Scour Analysis

- a. A scour analysis will be performed for all bridges, using the methods shown in the latest version of FHWA's HEC-18, [\(12-2\) Evaluating Scour at Bridges](#). The latest version of FHWA's HEC-20, [\(12-10\) Stream Stability at Highway Structures](#) should also be consulted regarding aggradation, degradation, and channel lateral migration considerations. Contraction and local (pier) scour calculations shall be performed. The design flood for scour shall be the 100-year flood or the overtopping flood if it is less than or equal to the 100-year flood. Scour should also be computed for the 500-year flood or the overtopping flood if it is greater than the 100-year flood and less than the 500-year flood.
- b. One of the primary locations where scour occurs at a bridge site is at the abutments. This is primarily due to an insufficient bridge opening or a large discharge in the overbank area. Guide banks (spur dikes) should be considered for protection against this type of scour. All bridge abutments shall be protected from scour by riprap. The proposed bridge opening(s) should be sized to minimize the possibility of abutment and overbank scour. Due to the over prediction of the present abutment scour equations, and with the approval of the FHWA, GDOT designs and protects the bridge endrolls with riprap and riprap aprons as specified in section 12.1.7, in lieu of using the results from the abutment scour calculations.
- c. If the bridge is located on or near a channel bend, the possibility of channel migration is increased. Placing the bridge foundations deep enough to withstand possible migration and channel scour is recommended. The bridge abutments should be placed far enough back so that any channel migration would not reach them during the lifetime of the bridge (75 years at a minimum). Channel stabilization should be considered using the methods in FHWA's HEC-23, [\(12-9\)](#)

10. Relief/Overflow Structures

Relief or overflow openings are needed on streams with wide floodplains. The purpose of additional openings in the floodplain is to pass a portion of the flood flow when there is a major flood event.

Basic objectives in choosing the location of relief openings include:

- Maintenance of flow distribution and flow patterns
- Accommodation of relatively large flood conveyances in the floodplain
- Avoidance of floodplain flow along the roadway embankment for long distances
- Crossing of significant tributary channels

Overflow structures should be considered for wide floodplains with a large amount of two-dimensional flow.

11. Cost Analysis

Cost estimates should be calculated for all proposed drainage structure alternatives. The most cost effective, hydraulically adequate alternate should be chosen.

12. Risk Assessment

When the bridge hydraulic design is selected, a risk assessment should be performed to determine the need for a more economical design approach. The risk assessment involves questions that will determine the need for a risk analysis. See the risk assessment chart in [appendix I](#).

13. Channel Changes

For both bridges and culverts, it may be desirable in some instances to construct a channel change to improve the hydraulic performance of the structure. Several options should be considered and coordinated with the Office of Environmental Services. Channel changes are to be avoided if at all possible.

If channel realignment is required, refer to chapter 11 for guidance on the design.

14. Wetlands/Environmental Concerns

Due to environmental concerns and/or extensive mitigation requirements, bridges may be required in lieu of box culverts to span wetland areas that have been delineated by the Office of Environmental Services.

Written documentation from the Office of Environmental Services is required to be placed in the hydraulic and hydrologic study to document the reasons why a box culvert should not be used as an alternate for the structure selection process. In addition, any limitations placed on the location of the endrolls and/or intermediate bents for the proposed bridge should be included in this documentation.

15. Preliminary Bridge Layout

The preliminary bridge layout is to be drawn using the Office of Bridge Design's MicroStation setup.

Information to be shown on the preliminary bridge layout includes, but is not limited to the following:

- a. A plan and elevation view of the proposed bridge drawn to scale. The existing bridge location is shown on the plan view. If any of the existing bridge and roadway fill is within the proposed bridge opening, this fill is shown as fill to be removed on the elevation view.
- b. The approximate original groundline should be shown in the elevation view.
- c. Historic highwater (flood of record) data including the elevation of floodstage, the date of occurrence, and the source of the data.
- d. Design year floodstage elevation, 100-year floodstage elevation, and the 500-year or the overtopping floodstage elevation. These floodstage elevations should be taken from the downstream face of the constricted section of the proposed bridge run in the HEC-RAS model, or from the full valley, un-constricted section of the WSPRO model.
- e. Hydrology data as follows:
 - Drainage area at the site.
 - Storm discharges for the design year, 100-, and 500-year, or the overtopping floods. Areas of opening below the design year, 100-, and 500-year, or the overtopping flood stages.
 - Mean flow velocities through the bridge opening for the design year, 100- and 500-year or the overtopping floods; for tidal bridges, these velocities would be the maximum velocities for the above storms.
 - Backwater values for the design year, 100- and 500-year, or the overtopping storms.

Note: For bridges with abnormal flood stage conditions, the above information in items (d) and (e) shall be shown for the normal and abnormal stage conditions.

- f. Scour table showing the contraction, local (pier) and total calculated scour depths for the 100- and 500-year or overtopping storms. The profile of the 100 year, 500-year, and/ or the overtopping storm theoretical scour line shall be shown on the bridge elevation view.
- g. Endroll riprap detail at the end bents.
- h. Berm elevation table. This table reflects the proposed berm elevations at the left and right edges of the bridge at each end bent. A note should be placed under this table that states *For bridge endroll staking purposes only*.
- i. A *Bridge Consists Of* table which includes the length, type, and number of superstructure spans; the number and type of substructure bents; the depth and type of riprap at the endrolls; length of guide banks (spur dikes); type and size of detour structure.
- j. Proposed grade data.
- k. Horizontal curve data.
- l. Bearing along the construction centerline for a tangent section.

- m. Benchmark data including station, offset, elevation, and physical description of the benchmark.
- n. Traffic data.
- o. Utilities, existing and proposed.
- p. Design data.
- q. A typical section if stage is constructed. A construction sequence is required if stage is constructed.
- r. Notes which specify the minimum allowable bottom of the proposed beam elevation as well as the proposed deck cross slope, superelevation, and how the deck drainage is to be addressed. This minimum allowable bottom of beam elevation is not usually equal to the proposed low bottom of beam elevation. The elevation shown in this note should be the lowest elevation that the proposed bottom of beam can be placed and still meet the vertical clearance requirements outlined in chapter 12.1.1 of this manual. The structural designer uses this elevation to determine if a deeper superstructure can be used in lieu of the proposed preliminary bridge layout.
- s. North arrow.
- t. Flow direction arrow; for tidal bridges, ebb tide and flood tide directions shall be shown.
- u. Destination arrows.
- v. Title block information. This information includes the route name and number, stream name, county, project number, PI number, existing bridge ID and serial numbers, and the date drawn.
- w. Consultant preliminary bridge layouts shall be stamped and signed by a registered professional engineer.

12.3.2 Contents of Riverine Hydraulic and Hydrologic Study

Refer to [appendix I](#) for the general list of content items needed for a riverine hydrologic study and an example of a GDOT hydrologic and hydraulic report

12.3.3 Methods/Procedures – All Tidal Projects

Note: The following methods/procedures are for bridge replacements, new locations, widenings, parallelings, culvert replacements, and extensions, unless otherwise noted. In general, the methods and procedures for riverine projects should be followed except as noted below.

Note: The methods and procedures listed in this section were taken from the following reports and publications. The methods and procedures listed below follow the recommendations of the Pooled Fund Study (SPR-3(22)) performed by Ayres Associates. The findings and results of the Pooled Fund Study are contained in the publications listed below in (a) and (b).

- a. *Phase III for the Pooled Fund Study, Development of Hydraulic Computer Models to Analyze Tidal and Coastal Stream Hydraulic Conditions at Highway Structures*, Ayres and Associates, Inc., March 2002

- b. *Phase II for the Pooled Fund Study, Development of Hydraulic Computer Models to Analyze Tidal and Coastal Stream Hydraulic Conditions at Highway Structures*, Ayres and Associates, Inc., December 1997
- c. FHWA Hydraulic Engineering Circular No. 25, [\(12-5\)](#) *Highways in the Coastal Environment, 2nd Ed.*
- d. FHWA Hydraulic Engineering Circular No. 18, [\(12-2\)](#) *Evaluating Scour at Bridges*
- e. *Requirements for Hydraulic Design Studies* [\(12-11\)](#)

The hydraulic design procedures for tidal bridges are new and relatively little experience has been gained in this area. Consequently, there is greater latitude afforded when selecting a hydraulic design procedure for tidal bridges as opposed to bridges over non-tidal rivers and streams. However, any procedure that is outside of the procedures described herein should be reviewed with the GDOT Hydraulic Engineer before it is used.

In tidal areas, bridge lengths are generally controlled by wetland considerations rather than hydraulics. The primary objective of the hydraulic analysis in tidal areas is to establish the profile grade elevation of the bridge and determine the predicted scour depths. Exceptions to this are where a bridge opening is being created or increased in an existing causeway or where a culvert is being used. In these cases, the hydraulic opening must be sized so that the velocities through the opening will not cause scour problems. A significant head difference can develop across a causeway due to either tide or wind conditions. Sufficient opening should be provided to relieve this difference. A detailed analysis should be conducted to correctly size the opening.

1. The following hydraulic computer models are approved by GDOT to be used when tidal flow is present:
 - a. The UNET computer model. This USACE computer model is a one-dimensional unsteady flow model.
 - b. The HEC-RAS computer model. This USACE computer model incorporates the UNET program for unsteady flow analysis.
 - c. The FESWMS or SRH-2D computer model. These two-dimensional models are presently recommended by the FHWA for tidal sites where complicated hydraulics exist. These models should be used in cases where there is a large amount of two-dimensional flow;
 - d. The RMA-2V computer model. This is a USACE two-dimensional computer model that may be used in lieu of FESWMS or SRH-2D.

Note: It may be necessary to use other hydraulic computer models such as WSPRO and HY-8 with the above computer models to analyze conditions at the bridge or culvert site.

2. Tidal hydraulic and scour analysis. Reference (b), listed above, provides 3 approaches for developing the boundary conditions for tidal hydraulic modeling: the USACE method, the empirical simulation technique (EST), and the single design hydrograph (SDH). The single design hydrograph method is recommended for design purposes and is described herein. For a description of the other methods, see the final report, phase II of reference (b).

The single design hydrograph (SDH) is a method that produces a single hydrograph based on the following equation:

$$S_{\text{tot}}(t) = S_p (1 - e^{-D/(t-t_0)^2}) + H_t(t) \quad (12.1)$$

Where:

- S_{tot} = Storm tide (combined surge and astronomical tide), ft
- D = R/f = storm half-duration, hr
- R = Radius of maximum wind (n-mile)
- f = Forward speed (knots)
- t = Time, hr
- t_0 = Time of hurricane landfall, hr
- H_t = Height of daily tide, ft
- S_p = Known storm surge height, ft

An alternative equation that better represents the falling limb of the surge hydrograph should be used for $t > t_0$.

$$S_{\text{tot}}(t) = S_p (1 - e^{-D/(t-t_0)^2}) - 0.14(t - t_0)e^{[-18(5-5_0)]} + H_t(t) \quad (12.2)$$

Equation 12.2 should be used for $t < t_0$.

The SDH equations were developed using the following data:

- a. Historic storm surges with an elevation equal to that of the FEMA, NOAA, or ADCIRC prediction (for each stage of interest)
- b. A duration equal to the average value of the historic durations at the site considered
- c. Combining these data with a mid-rising tide

The resulting hydrograph is then applied as the downstream boundary condition for the hydraulic model. If discharges from upland (riverine) runoff are to be considered, these discharges are inserted in the form of a hydrograph that corresponds to the timing of the tidal hydrograph for the upstream boundary conditions.

Tide data obtained from NOAA tide gages should be used to calibrate the hydraulic computer model. If the tide data is not available, 2 or more continuous recording tide gages should be placed on the tidal stream to obtain calibration data. The high and low mean and spring tide elevations shall be provided at the project site.

The hydraulic analysis shall include modeling for the 10-, 25-, design, 100- and 500-year, or the overtopping upland stream floods with tidal influence as judged appropriate. The effects of the design, 100- and 500-year or the overtopping storm tidal surges shall be analyzed along with the appropriate upland (riverine) flows.

For scour analyses of tidal bridges, the procedures in the latest edition of FHWA HEC-18, (12-2) *Evaluating Scour at Bridges* should be followed. The analyses shall be done for the 100- and 500-year or the overtopping upland riverine floods along with the appropriate tidal influences, as well as the 100- and 500-year or the overtopping storm tidal surges combined with the appropriate upland riverine flows.

If the ultimate scour depths predicted by the methods in HEC-18 seem unreasonable, an analysis reflecting time-limited contraction scour can be used to predict scour depths. This method can be used in cases where the ultimate scour depth is clearly excessive considering the relatively short duration of the typical storm tide event. A sediment transport model can be developed that uses the same information as the live-bed and clear-water contraction scour equations but computes the scour based on a sediment transport equation coupled with time-dependent sediment continuity principles.

3. Storm Surge Information. The USACE has produced a database of storm surge hydrographs for 134 historic hurricanes that hit the Atlantic and Gulf coasts over a 104-year period. These events were simulated without tides on a hydrodynamic storm surge simulator. The surge hydrographs generated reflect the storm surge heights only and must be combined with astronomic tidal elevations for proper results. The data are available for near coastal tide stations called ADCIRC stations. See reference (b), listed above, for a list of ADCIRC stations.

Surge heights can also be obtained from NOAA and the FEMA flood insurance studies for coastal counties. Care should be exercised in using the FEMA data because the tide heights are given along transects, but the specific point where the height applies is not clearly identified. The tide data in the NOAA report is for the coast, so the surge must be translated upstream to the bridge site using either one or two-dimensional flow analysis. Wave height computations should be based on the USACE Shore Protection Manual as needed.

4. Historic storm and site data. Historic hurricane storm data for the proposed bridge site should be investigated. Possible sources of information are the NOAA tides and currents web site, <http://tidesandcurrents.noaa.gov/products.html>, the NOAA storm data base available on diskette from NOAA entitled *North Atlantic Storms 1886-1994*. Other data sources may be newspaper archives, NOAA weather records, and library resources.
5. Combining storm tides with upland runoff. At this time, only general guidance is available for determining the appropriate upland runoff to combine with a storm tide. The following recommendations are given for including upland runoff in a storm tide analysis:
 - a. If the upland basin is large and an upland flood would require significant time to reach the tidal zone, then the long term average flow should be used as an upstream flow boundary.
 - b. If the upland basin is small and a hurricane induced upland flood could reasonably reach the tidal zone during the storm surge, use a long-term average flow during the storm flood-tide and time the upland flooding to occur with the storm ebb-tide.
 - c. When simulating upland flooding during the storm ebb-tide, a reasonably-shaped hydrograph of the flood discharge will produce the most accurate estimation of the

- worst-case conditions. A constant flood discharge may be used during ebb-tide, but this could produce an overly-conservative flood estimate of the worst-case conditions.
- d. If the upland flood discharge is small in relation to the storm tide discharge, it can be included during the ebb storm-tide without causing an excessive flood estimate.
6. Establish minimum bridge and roadway grades. The minimum height for the bottom of the bridge superstructure as well as the roadway grade should be set as specified in section 12.1.1.
 7. Culverts in tidal streams. Culverts in tidal streams should be analyzed with the unsteady flow module in HEC-RAS except when the following criteria exist:
 - a. Existing culvert barrels are being extended by less than 50% of the original length, or the existing culvert is being replaced in-kind and the culvert barrels are being extended by less than 50% of the original length.
 - b. The profile grade of the roadway is not being raised a significant amount.
 - c. No scour or flooding problems exist, and the potential for any significant problems seems low.

If the above three conditions are met, then no computer model is required, and a letter documenting the above conditions shall be sent to the Office of Engineering Services for their review and approval.

The rising and falling tidal surges will each have a point of maximum outlet velocity, which will occur approximately mid-way between high and low tide. The exact timing of both points needs to be determined so that outlet scour protection may be designed for both ends of the culvert under maximum velocity conditions.

Note: Caution should be exercised when using tidal information from different sources. Multiple datums are often used and should be addressed before the data is used.

12.3.4 Contents of Tidal Hydraulic and Hydrological Study

Refer to [appendix I](#) for the general list of content items needed for a tidal hydrologic and hydraulic study.

12.3.5 Methods/Procedures – All Riverine Major Culvert Projects

Note: The following methods and procedures are for culvert replacements, new locations, and culvert extensions that do not involve an existing or proposed bridge and are non-tidal. If an existing or proposed bridge is involved, see section 12.3.1. If the site is tidal, see section 12.3.3.

The methods and procedures in this section and in section 12.3.6 are for culverts that meet any of the following conditions:

- For existing or proposed culverts that have a total span length along the roadway of 20 feet or more.
- For all sites located on streams where the 100-year floodplain has been delineated on FEMA maps.

- For all sites located on streams that are named on county and/or USGS maps.
- For all sites that have a significant risk associated with the project such as existing or potential flooding problems.
- For all sites that are affected by downstream constrictions/obstructions or abnormal flood stages from another stream.

At the project manager's or hydraulic engineer's discretion, the methods and procedures in this section and in section 12.3.6 may be required at any site.

For all other sites, the project manager of the applicable Department design office can make the determination that a less detailed study may be performed for a site. At a minimum, this less detailed study should include the required drainage calculations, hydraulic value calculations and/or computer runs for the existing and proposed conditions, the location of the culvert site shown on the roadway cover sheet, and the culvert shown on the plan and profile roadway sheet. See chapter 8 of this manual for additional details and information.

1. The following hydraulic computer models are approved by GDOT to be used when tidal flow is not present:
 - a. The FHWA HY-8 culvert analysis model.
 - b. The USACE computer model HEC-RAS.
 - c. The FHWA computer model WSPRO.
 - d. If the drainage area contains significant storage volume upstream of the project site, the runoff must be determined by developing unit hydrographs and routing the various floods through the basin. The storage and any existing outlet structures should be considered.

Note: The USACE computer model UNET is a one-dimensional unsteady flow model with the capabilities of flood routing and storage calculations. The UNET model is contained in the HEC-RAS model.
 - e. For regulatory FEMA hydraulic models produced from the USACE software HEC-2, HEC-RAS will be used to duplicate the current regulatory FEMA hydraulic model from HEC-2 to produce the floodway and profile runs.

Note: Computer models other than those listed above may be considered for special floodplain conditions.
2. Investigate the flood history of the stream. Sources for this information include, but are not limited to the following:
 - USGS gage records
 - Existing culvert and maintenance files (Note: The Office of Maintenance maintains electronic files for culverts with spans of 20 feet or more.)
 - Previous studies done by the DOT, USACE, FEMA and the USGS
 - Information from local residents
 - Information from the local government

- Information from local GDOT personnel
 - Hydraulic engineering field report
3. Investigate the culvert site history. Some sources of information are:
- The culvert inspection and maintenance files
 - A comparison of the original culvert plan and profile with the currently surveyed profile. Based on this information, an indication of the long-term channel stability and aggradation or degradation can be estimated. An evaluation of the performance of the existing culvert can also be made
 - For proposed culvert extensions only: A condition survey for the existing culvert shall be requested from the Office of Maintenance. This survey will recommend any needed repairs to the existing culvert, or will recommend the replacement of the existing structure if the repairs are extensive.
4. Determine the project site hydrology for the culvert.

The same procedure outlined in section 12.3.1, paragraph 4. for riverine bridge projects should be followed to determine the hydrologic characteristics for the culvert project location.

5. Provide a field inspection of the project site.

The hydraulic engineer performing the study and computer modeling shall visit the culvert site(s) and perform a site inspection. During the field inspection, the engineer should evaluate the following:

- Characteristics and hydraulic properties of the stream
- Performance of the existing culvert (if applicable)
- Channel and floodplain geometrics
- Adequacy and accuracy of the survey data

In addition, the following site conditions should be noted:

- Buildings or structures in the floodplain that may be subject to flooding
- Scour and/or undermining problems at the existing culvert (if applicable)
- Evidence of past channel migration or potential for future migration

During the field inspection, stream crossings immediately upstream or downstream of the project site on the same stream should be visited and the performance of the structures noted

6. Determine the extent of the survey data.

The hydraulic engineer shall determine the extent of the survey data required to accurately model the project site based on the requirements from the GDOT Survey Manual. Please refer to this manual for the required survey information.

See the hydraulic engineering field report in the GDOT Survey Manual for a detailed listing of the minimum survey data required. Although this field report is written for bridge projects, the same survey information is needed for major culvert projects.

Note: For projects located on a stream where a detailed FEMA study has been performed, the channel cross sections from the FEMA study may be used to supplement the project survey data in the development of the project hydraulic model. Care must be taken to review the FEMA data for completeness and accuracy since quite a number of the FEMA studies contain outdated information.

7. Perform a hydraulic analysis.

a. The hydraulic computer model shall be used to determine the existing and proposed conditions at the site. The 2-, 10-, design-year, 100- and 500-year, or the overtopping storm shall be modeled for the project site. The design flood shall be conveyed through the culvert opening, while floods greater than the design flood **may** be conveyed over the roadway and through the culvert opening. The 2-year flood is modeled for USACE permit purposes. The 10-year storm is used to size the detour structure.

Note: The 2-year storm is used to size the detour structure on local roads not designated as state routes that have a design year ADT less than 400 VPD.

b. The FHWA HY-8 computer culvert analysis model may be used to calculate tailwater solutions using the irregular channel option, and to size a culvert and set the minimum roadway grade for the project site, **if the following criteria are met:**

1) The channel is uniform and the channel slope is constant

2) Tailwater at the site is not affected by downstream conditions such as another roadway crossing, a natural constriction of the channel and/or floodplain, or a confluence with another stream.

3) If very accurate tailwater elevations are required due to the risk associated with the project such as existing or possible upstream flooding problems, the engineer may choose to use the more detailed analysis described in item (c) below

c. For all other project sites the natural or unrestricted highwater profiles should be developed using the WSPRO or HEC-RAS computer models. The results of these computations should be used to determine the various tailwater heights, size the culvert, and evaluate the culvert hydraulic performance using HY-8. Another option is to use the culvert routine within HEC-RAS. The HEC-RAS computer model contains an option for an arch type bottomless bridge culvert.

d. If the project is within a FEMA regulatory floodway, FEMA guidelines must also be satisfied. See chapter 2, *Agency Coordination and Regulations*.

Note: For projects that involve FEMA or require a more detailed analysis be performed as described in items (b) and (c), the special projects section of the Office of Road Design shall provide the necessary support and assistance.

8. Consider hydraulic design guidelines for culverts.

a. Culvert Replacements

In general, box culverts are placed at sites which have favorable floodplain conditions, such as in a well-defined stream channel and where silt is not likely to accumulate in the culvert barrels. For this reason, culverts are generally not placed in swampy areas or sites that are frequently affected by abnormal stage conditions.

- 1) Design criteria in section 12.1 of this chapter shall be followed where applicable to culverts.
 - 2) GDOT standard sizes and skews for concrete box culverts are to be used. Standard culvert sizes range from a single barrel 4 ft wide by 4 ft high box to a five barrel 10 ft wide by 12 ft high box. Standard skews are 45, 60, 75 and 90 degrees.
 - 3) Culvert width is normally set by matching the width and profile of the stream channel and designing the culvert to flow full for the design year and 100-year storms. Design storm frequencies are established in the section 12.1 of this chapter.
 - 4) Culverts shall be sized to provide acceptable flow velocities and backwater values
 - 5) Profile grades along the proposed roadway shall be set to meet the requirements as specified in section 12.1.1.
- b. Culvert Extensions
- 1) In general, the above recommendations (section 12.3.5, paragraph 8a) for culvert replacements apply where applicable.
 - 2) A hydraulic analysis is required for culvert extensions because length is a factor if the culvert flow is under outlet control. In addition, an upstream extension may affect headwater if the culvert is under inlet control.
 - 3) The culvert history should be investigated. The maintenance records should be reviewed for any past or existing scour problems at the site. The engineer should perform a site inspection to observe any existing or possible future scour and/or flooding problems.
 - 4) If there is evidence of flooding and/or scour problems or if the culvert extension/proposed roadway work is so significant that the calculations indicate a larger structure is required, the engineer must make the necessary adjustments to the existing structure until it is hydraulically sufficient. These adjustments can include adding barrels to the existing culvert or replacing the existing culvert.
 - 5) The possibility of replacing the existing culvert with a more cost-effective structure should be checked if extensive repairs to the existing culvert are required.

c. Bottomless Culverts

Bottomless culverts are used where the natural streambed is kept intact for ecological and environmental concerns. The culverts most often used in these cases are concrete box culverts and arch type bridge culverts. These bottomless arch structures can also be used as an alternate to a standard box culvert or small bridge for non-environmental reasons.

Due to the potential for scour problems at these sites, a scour analysis shall be performed as described below in paragraph 9 of this section. The culvert foundations shall be placed deep enough to withstand the possible channel migration and scour.

Acceptable foundations for the arch type bridge culverts are listed below:

- 1) Spread footings founded in rock or scour resistant material below the streambed elevation
- 2) Pile footings
- 3) Concrete bottoms can be used where environmental issues are not a concern

Please note that riprap is not recommended to be placed as a scour countermeasure for new arch type bridge culverts.

An alternative to constructing a bottomless culvert is to countersink a standard box culvert so the bottom is approximately 20% of the culvert is below the natural streambed elevation. This allows streambed material to fill in the bottom of the culvert, and create a more natural passageway for wildlife traveling from one end of the culvert to another. The countersunk area of the culvert should be added to the required culvert area from the design calculations and should not be included in the culvert cross-sectional area when performing hydraulic analyses.

Another alternate is to build a small bridge at the site.

9. Perform a scour analysis

- a. A scour analysis will be performed for all bottomless culverts, using the methods shown in the latest version of the FHWA HEC-18, [\(12-2\) Evaluating Scour at Bridges](#). The latest version of FHWA HEC-20, [\(12-10\) Stream Stability at Highway Structures](#) should also be consulted for aggradation, degradation and channel migration considerations. General contraction, abutment, and local (pier) scour calculations shall be performed. The design flood for scour shall be the 100-year flood or the overtopping flood if it is less than or equal to the 100-year flood. Scour should also be computed for the 500-year flood or the overtopping flood if it is greater than the 100-year flood and less than the 500-year flood.
- b. The predicted scour depths yielded by the scour analysis shall be provided to the Office of Materials and Research (Forest Park Lab) for a foundation investigation and a recommendation on footing placement. Scour tables showing the general contraction, abutment, local (pier) and total calculated scour depths for the 100- and 500-year or the overtopping storms shall be provided. The profile of the 100-year, 500-year, and/or the overtopping storm theoretical scour line shall be shown on the roadway plan elevation view.
- c. The proposed culvert opening shall be sized to minimize the possibility of scour problems.

Note: The FHWA has an ongoing scour study for bottomless culverts. Updates and recommendations from the FHWA scour study should be used when available.

10. Use wingwalls and aprons.

Wingwalls and aprons should be used to retain and protect the embankment and provide a smooth transition between the culvert and the channel.

11. Perform a cost analysis.

Cost estimates should be calculated for all proposed drainage structure alternatives. The most cost effective, hydraulically adequate alternative should be chosen.

12. Perform a risk assessment.

When the culvert hydraulic design is selected, a risk assessment will be performed to determine if a more economical design approach should be considered. The risk assessment includes questions that will determine the need for a risk analysis. See the risk assessment chart in [appendix I](#).

13. Consider channel changes.

Refer to section 12.3.1, paragraph 13 regarding the criteria for channel improvements.

14. Provide roadway plan information.

Bridge culvert information to be shown on the roadway plans includes, but is not limited to the following:

- a. Plan and elevation view of the proposed bridge culvert. The culvert size, length, location, and invert elevations shall be shown.
- b. Approximate original groundline should be shown in the elevation view.
- c. Historic highwater (flood of record) data including: elevation of highwater, date of occurrence, and source of data.
- d. Design year headwater elevation, 100-year headwater elevation and the 500-year, or the overtopping headwater elevation.
- e. Hydrology data:
 - Drainage area at the site
 - Storm discharges for the design year, 100- and 500-year, or the overtopping floods
 - Areas of opening below the design year, 100- and 500-year, or the overtopping flood stages
 - Flow velocities through the culvert opening for the design year, 100- and 500-year, or the overtopping floods
- f. Type and size of the detour structure
- g. Proposed grade data
- h. Horizontal curve data
- i. Bearing along the construction centerline
- j. Benchmark data
- k. Traffic data

- I. Utilities, existing and proposed
- m. A construction sequence is required if stage is constructed
- n. North arrow
- o. Flow direction arrow; for tidal sites, ebb tide and flood tide directions shall be shown
- p. Destination arrows
- q. Titleblock information, which includes route name and number, stream name, county, PI number, and the date drawn.

12.3.6 Contents of Riverine Hydraulic and Hydrological Major Culvert Study

Refer to [appendix I](#) for the general list of content items needed for a riverine hydrologic and hydraulic major culvert study.

12.3.7 Hydraulic and Hydrologic Study Procedures/Design Office and Consultant Responsibilities

General Guidelines

All Hydraulic Studies

1. A hydraulic and hydrologic study shall be performed for a project site that involves an existing or proposed bridge with the following exceptions:

The GDOT bridge hydraulics engineer can make an assessment, on a case to case basis that the proposed bridge will have a low potential for scour and adverse hydraulic effects. The only cases in which this assessment can be made are when the proposed bridge is:

- over a major reservoir where the flood flows are regulated
- spanning a wetland area with a relatively small drainage area
- over a roadway or railroad that also spans a very small stream
- clearly spanning the entire floodplain with no bents within the flood flow

In the above cases, as determined by the GDOT bridge hydraulics engineer, hydraulic computer modeling and the associated hydraulic and scour calculations are not required. A written report, site inspection, and preliminary bridge layout are required.

2. The units for the hydraulic and hydrologic study and preliminary bridge layout shall be consistent with the proposed roadway plans.

In-House Hydraulic Studies

1. The Bridge Design Hydraulics section shall be responsible for performing the hydraulic and hydrologic studies for all bridge replacement and bridge widening/paralleling projects, as well as new locations where bridges are proposed. This responsibility includes performing all modeling necessary for coordination with FEMA and the affected community for these projects.

2. The Roadway Design office and the various district offices shall be responsible for performing culvert and pipe studies in which a flood profile model such as WSPRO, HEC-RAS, or HEC-2 is not required. The Hydraulics Group in the Office of Design Policy and Support is available for guidance, assistance, and review on a case by case basis for culvert studies that involve the use of flood profile programs such as WSPRO or HEC-RAS as well as hydraulic studies for the longitudinal encroachment on floodplains by roadways. The Hydraulics Group in the Office of Design Policy and Support will also provide the necessary assistance and support for performing all hydraulic modeling necessary for coordination with FEMA and the affected community for these projects.
3. All hydraulic and hydrologic studies shall be reviewed and signed by the Department head or district engineer or authorized representative within the design or district office where the study is performed.
4. All hydraulic and hydrologic studies shall be reviewed by the Office of Engineering Services at the preliminary field plan review inspection.

Consultant Projects

Consultant Responsibilities

The consultant is responsible for the following:

1. Sizing the most cost effective drainage structure in accordance with the design criteria, procedures and guidelines contained within this manual.
2. Proficiency in the knowledge and use of all required computer models, as well as the required methods, procedures, calculations, publications, and design criteria contained within this manual.
3. Obtaining or requesting from the liaison engineer/project manager any survey data that is required to accurately model the project site, depending on the contract. In addition, the consultant shall be proficient in the use of InRoads/CAiCE.
4. Investigating the bridge site history by searching the electronic files for the existing bridges maintained in the Office of Maintenance. These electronic files often contain old hydraulic studies, bridge foundation investigations, and existing bridge plan sheets that may be useful in assessing scour or debris problems. For later existing studies, bridge foundation investigations, and bridge plan sheets that may have been done but are not contained in the Office of Maintenance electronic files, the consultant should contact the liaison engineer/project manager for assistance.
5. Obtaining or requesting any profile grade change(s) from the liaison engineer/project manager that is required for the project to meet the guidelines contained within this manual. If the consultant is also producing the roadway plans for the project, setting the profile grade(s) to meet these guidelines is the consultant's responsibility.
6. Obtaining or requesting any horizontal alignment change(s) from the liaison engineer/project manager that would enable the bridge to be built more efficiently or would limit encroachment on stream channels and/or floodplains.

7. Obtaining approval from the hydraulic engineer before using a computer model other than the HEC-RAS or the WSPRO model for non-tidal conditions.
8. Obtaining approval from the hydraulic engineer/project manager for a channel change.
Note: Due to the extensive mitigation required for channel changes, approval for a channel change is extremely unlikely.
9. Obtaining approval from the hydraulic engineer/project manager before proceeding with plans for bridge widening projects that replace or significantly change the existing bridge.
10. Sizing a drainage structure for a site within a FEMA regulatory floodway which meets GDOT's, the affected communities, and FEMA's standards and approval. The consultant shall provide the necessary forms, floodway and flood profile computer modeling, and other supporting documentation as required for approval. Upon approval of the hydraulic study and preliminary bridge layout by GDOT, the consultant shall perform the necessary community and /or FEMA coordination.
Note: All supporting documentation, along with copies of correspondence and approvals from the community and/or FEMA shall be provided to GDOT for their records and use.
11. For state funded projects, where the consultant has performed a hydraulic study for the community, the consultant, at a minimum, shall provide GDOT with a copy of a letter of concurrence from the community and approval from FEMA (if required).
12. Making any necessary adjustments and/or corrections to the hydraulic and hydrologic study, preliminary bridge layout, computer models, and FEMA documentation as required as a result of reviews, field inspections, bridge stakeouts, and/or bridge foundation investigations.
13. Providing GDOT with an electronic copy of the final hydraulic and hydrologic study and FEMA package (if applicable). This electronic copy shall be in Adobe Acrobat Portable Document Format (PDF). This PDF file shall not be password protected. An electronic copy of the preliminary bridge layout is also required. The preliminary bridge layout is to be drawn using the Office of Bridge Design's MicroStation setup. For interstate and FHWA full oversight projects, the consultant shall provide an additional hard copy of the hydraulic study.

In addition to the items above, the cover sheet of the completed hydraulic and hydrologic study must state "Hydraulic study prepared by" and must include the signature and Georgia PE stamp for the engineer who prepared the study. In addition, the cover sheet of the study must also state "QC/QA performed by" and must include the PE stamp and signature of the engineer performing the QC/QA for the study. The engineer who prepared the study shall not be the same engineer performing the QC/QA. The preliminary bridge layout must be signed and stamped by a registered professional engineer.

Common Omissions and Points of Emphasis

1. Sizing of proposed bridges for replacement and new location projects.

In many cases, a proposed bridge opening has been sized to approximate or to be slightly larger than the existing structure. This bridge may or may not be the minimum length bridge that is needed at the site. In other cases, a proposed bridge is sized that can be reduced in

length due to a lack of potential upstream flooding problems or very low proposed backwater and flow velocity values.

The proposed drainage structure should be sized as the minimum length bridge, smallest culvert, or most cost effective combination of drainage structures that have acceptable backwater and velocity values that fits the stream geometry and meets applicable FEMA requirements while adhering to the procedures, guidelines and design criteria of this manual.

The minimum length bridge that can be placed at a site due to the stream channel geometry is specified in section 12.3.1, paragraphs 8.a, b, c, and d. If this minimum length bridge has acceptable backwater and flow velocities, and meets applicable FEMA requirements, then this is the proposed bridge length that should be chosen. If not, the bridge length must be increased until acceptable backwater and flow velocities are achieved.

The 100-year backwater shall be limited to 1 foot above the unrestricted or natural 100-year water surface profile. As a general rule, to minimize scour, the maximum desirable stream channel velocity values for new bridges should be in the range of 1.5 to 1.75 times the natural/unrestricted channel velocity for the design year and 100-year storms.

The reason(s) for choosing the proposed drainage structure should be clearly stated in the written report. Example justifications are: "The 240 ft long bridge was chosen as the replacement structure for this site, because it was the minimum length bridge that has acceptable backwater and channel velocities."; or "The 240 ft long bridge was chosen as the replacement structure for this site, because it was the minimum length bridge that aligns well with the approach channel geometry and has acceptable backwater and channel velocities."

2. A hydraulic table that summarizes the following hydraulic information for the existing and proposed conditions should be placed near the front of the study immediately following the written reports. Include tables showing the design year, 100- and 500-year storm hydraulic values for the natural (unconstricted), existing, and proposed conditions along with any applicable alternatives. Include the flood stages at the bridge and the unconstricted and constricted flood stages at the upstream approach section along with the areas of opening under flood stage, discharge through the bridge and over the roadway, channel and mean velocities through the bridge, and backwater values. The two-year flood stage elevation, along with the design year and 100-year storm natural (unconstricted) channel velocities should be shown on this sheet. If the site is affected by abnormal flood stages, separate tables should be shown for the design year and 100-year storm stream floods and abnormal floods.

Note: This table is separate from the hydraulic computer model generated tables. This table contains all of the above-specified hydraulic values that can easily be compared for each storm frequency and condition (i.e., existing, proposed, alternatives). See the hydraulic table contained in the example hydraulic study in [appendix I](#) for guidance.

3. Model all floodplain constrictions/obstructions and abnormal flood stage conditions that affect the project site. See section 12.1.11. The consultant is responsible for recognizing and identifying these conditions at the outset of the project. The costs for modeling these conditions shall be included in the initial work order. If the consultant is responsible for

providing any additional survey information that is required to model the project site, these costs should be included as well. The drainage structure shall be modeled and sized based on these conditions.

4. The hydraulic engineer performing the study and computer modeling shall visit the project site and perform a site inspection.
5. The hydraulic engineer is responsible for the span arrangement and bent skew of the proposed bridge.
6. A registered professional engineer shall stamp and sign the cover of the hydraulic and hydrologic study as well as the preliminary bridge layout.
7. The preliminary bridge layout is to be drawn using the Office of Bridge Design's MicroStation setup.
8. Box culvert alternatives must be considered at all sites with a drainage area of 20 square miles or less. The results of this consideration are to be included in the hydraulic study. If it is determined that a box culvert will be hydraulically satisfactory at the project site, the final decision as to whether a box culvert or bridge will be used should be based on a cost comparison. This cost comparison is to be included in the hydraulic study. The computer modeling for the culvert and bridge alternates should be included along with hydraulic tables showing the results for both alternates. The reasons that the proposed drainage structure was chosen or eliminated from consideration should be included in the written report of the hydraulic study.

GDOT standard size and skew concrete box culverts are to be used at proposed culvert sites. These culvert sizes range from a single barrel 4 ft wide by 4 ft high box to a five barrel 10 ft wide by 12 ft high box. Standard skews are 45, 60, 75, and 90 degrees.

Environmental considerations and/or unfavorable floodplain conditions may preclude a box culvert alternative at a site. If this is the case, no computer modeling is necessary for the box culvert option. The reasons for this determination should be stated in the written hydraulic report. Documentation from the Office of Environmental Services is required to be included in the study if a box culvert is precluded due to environmental considerations.

9. If a bridge is required to be constructed at a site due to environmental considerations, written documentation from the Office of Environmental Services is required to be placed in the hydraulic study. This documentation should state the reasons that a box culvert cannot be constructed at the project site. In addition, any limitations placed on the location of the endrolls and/or intermediate bents for the proposed bridge should be included in this documentation.
10. Errors that should be checked for in the hydraulic and hydrologic studies include negative backwater values, and/or storm flow velocities through the bridge opening that are less than the flow velocities for the natural, unconstricted conditions. When a constriction, such as a roadway, is placed into a floodplain, it will not lower the upstream water surface elevation from the natural conditions, nor will the flow velocities through the constricted bridge opening be less than the natural condition flow velocities. Stream channel improvements that extend a significant distance upstream and downstream of the crossing could reduce

the water surface elevations. Due to environmental concerns, channel improvements to this extent are rare. Model parameters should be rechecked if either of the conditions is observed in the model results.

11. The elevation given on the preliminary bridge layout with the following note: "The minimum bottom of beam elevation for the proposed bridge shall be no lower than "xxx.xx," is often incorrect. This elevation is not usually equal to the proposed low chord elevation. The elevation shown in this note should be the lowest allowable elevation that the proposed bottom of beam can be placed and still meet the vertical clearance requirements given in chapter 12.1.1 of this manual. The structural designer uses this elevation to determine if deeper superstructure can be used in lieu of that proposed on the preliminary bridge layout.

Review of Consultant Hydraulic and Hydrologic Studies

Note: GDOT review of the consultant's work shall not relieve the consultant of the responsibility and accountability for sizing drainage structures in accordance with the design criteria, procedures, and guidelines contained within this manual. Furthermore, GDOT review is not intended to be used as a quality control device by the consultant.

GDOT's review is cursory, noting obvious discrepancies, and may be as minimal as a check of the preliminary bridge layout. The parameters and values used to model the site are not thoroughly checked. Specific numbers are, in general, not checked.

1. Bridge Design Office Consultant Studies
 - a. The Bridge Design Hydraulics section is responsible for the review and acceptance of consultant studies and preliminary bridge layouts performed through the Bridge Design Office.
 - b. All hydraulic and hydrologic studies shall be reviewed by the Office of Engineering Services at the preliminary field plan review inspection.
2. Road Design Office, Urban Design Office, Consultant Design Office, District Office, and State AID Office Consultant Studies for Bridge Projects
 - a. The consultant shall submit the hydraulic study along with a copy of the preliminary bridge layout to the project manager.
 - b. The project manager shall provide the Bridge Design Office with a copy of the hydraulic and hydrologic study, a copy of the preliminary bridge layout, the project concept report, and a set of roadway plans for review.
 - c. The Bridge Design Office shall provide review comments for the hydraulic and hydrological study and preliminary bridge layout to the project manager. These comments will be copied to the Office of Engineering Services.
 - d. The project manager is responsible for providing the consultant with these review comments. The consultant is responsible for insuring that these review comments have been addressed.
 - e. The consultant shall resubmit the hydraulic study and preliminary bridge layout addressing the review comments to the project manager. The project manager shall

resubmit the hydraulic study and preliminary bridge layout to the Bridge Design Office for review.

Note: This step may be omitted at the discretion of the Bridge Design Office.

- f. After the hydraulic study and preliminary bridge layout have been accepted by the Bridge Design Office (**Note:** This step may be omitted at the discretion of the Bridge Design Office), the project manager shall submit the hydraulic and hydrologic study and preliminary bridge layout to the Office of Engineering Services as part of the total plan package for the preliminary field plan review.
- g. The consultant shall provide the Bridge Design Office with an electronic copy of the final hydraulic and hydrologic study and FEMA package (if applicable). This electronic copy shall be provided as a PDF. This PDF file shall not be password protected. Two half size copies of the preliminary bridge layout are also required. An electronic copy of the preliminary bridge layout is also required. For interstate and FHWA full oversight projects, the consultant shall provide an additional hard copy of the hydraulic study.
- h. If the hydraulic study and/or preliminary bridge layout is changed for any reason, the project manager shall provide updated copies, as required in item number 7, of the final hydraulic and hydrological study and preliminary bridge layout to the Office of Bridge Design.

For Culvert Projects (Including Bridge Culverts)

1. The project manager is responsible for the review and acceptance of consultant studies. The Hydraulics Group of the Office of Design Policy and Support is available to provide the necessary assistance and support on a case by case basis.
2. All hydraulic and hydrologic studies shall be reviewed by the Office of Engineering Services at the preliminary field plan review inspection.

Standard Distribution for Completed Hydraulic and Hydrologic Studies and Preliminary Bridge Layouts

1. Office of Materials and Research (Forest Park Lab) for BFI (Bridge Foundation Investigation): Two full-size copies of the preliminary bridge layout with two half-size sets of roadway plans. If the bridge is to be designed using LRFD, state this.
2. Project manager: Two full-size copies of the preliminary bridge layout along with one copy of the hydraulic and hydrological study for the preliminary field plan review (PFPR). The Office of Engineering Services will provide their review as part of the PFPR.
3. District site inspection: All bridge sites are inspected by representatives of the district engineer. Send two full-size copies of the preliminary bridge layout along with a full-size set of roadway plans requesting that the endrolls and intermediate bents be staked out. Request that the results of the site inspection be provided to the Bridge Design Office in writing.

4. Office of Environmental Services: One half-size copy of the preliminary bridge layout along with one half-size set of roadway plans.
5. Coordination involving U.S. Coast Guard navigation channels: Send a separate transmittal to the Office of Environmental Services (OES), including one copy of the preliminary bridge layout and one set of roadway plans. Existing bridge plan sheets detailing the navigation channel and any previous permit drawings should also be provided. Send this package to OES requesting that OES secure an FHWA exemption for a U.S. Coast Guard permit. If an exemption cannot be obtained, then the required U.S. Coast Guard permits for the proposed structure should be secured by:
 - a. For in-house projects performed by the Office of Bridge Design, the Bridge Design Office is responsible for securing the required USCG permits.
 - b. For Bridge Design Office consultant projects, the required USCG permits should be secured by the Bridge Design Office or the consultant at the Bridge Office's discretion.
 - c. For consultant projects outside of the Bridge Design Office, GDOT's project manager is responsible for securing, or directing the consultant to secure these USCG permits.
6. Tennessee Valley Authority (TVA) Coordination: Provide one copy of the hydraulic and hydrologic study to the Office of Environmental Services or the Department's project manager for coordination with the TVA.
7. Office of Bridge Design: One copy of the hydraulic and hydrologic study along with two half-size copies of the preliminary bridge layout. An electronic copy of the hydraulic and hydrological study in PDF is also required. This PDF file shall not be password protected.
8. General Files: One copy of the hydraulic and hydrological study.
9. FHWA for approval (interstate and full oversight projects only): One copy of the preliminary bridge layout, one set of roadway plans, one copy of the hydraulic and hydrologic study. ALL PLAN COPIES SHALL BE HALF-SIZE.

Note: For consultant projects outside of the Bridge Design Office, the Department's project manager shall make the above distribution. Copies of the bridge foundation investigation (BFI) and the results of the district's site inspection and bridge stakeout should be provided to the Bridge Design Office. Also, copies of the FHWA exemptions for USCG permits, or the required USCG permits for these bridges should be provided to the Office of Bridge Design.

For projects that require coordination with the affected community and/or FEMA, see chapter 2 of this manual for the required additional distribution.

Chapter 12 References

1. Arcement, G.J., Schneider, V.R., USGS, 1984, [Guide for Selecting Manning's Roughness Coefficients for Natural Channels and Flood Plains](#). TS-84-204. Federal Highway Administration (FHWA), U.S. Department of Transportation, Washington, D.C.
2. Arneson, L.A., Zevenbergen, L.W., Lagasse, P.F., Clopper, P.E. 2012, Evaluating Scour at Bridges, [Hydraulic Engineering Circular No. 18](#), FHWA-HIF-12-003. Federal Highway Administration (FHWA), U.S. Department of Transportation, Washington, D.C.
3. Barnes, Harry H. [Roughness Characteristics of Natural Channels](#). USGS Water Supply Paper 1849. (1987).
4. Bradley, Joseph N., 1978, Hydraulics of Bridge Waterways, [Hydraulic Design Series No. 1](#), Federal Highway Administration (FHWA), U.S. Department of Transportation, Washington, D.C.
5. Douglass, Scott L., Krolak, Joe. 2008, Highways in the Coastal Environment, [Hydraulic Engineering Circular No. 25](#), Second Edition. FHWA-NHI-07-096. Federal Highway Administration (FHWA), U.S. Department of Transportation, Washington, D.C.
6. Feaster, Toby D., Gotvald, Anthony J., Weaver, J. Curtis 2011. "Methods for Estimating the Magnitude and Frequency of Floods for Urban and Small, Rural Streams in Georgia, South Carolina, and North Carolina, 2011" U.S. Geological Survey Scientific Investigations Report 2014-5030.
7. Gotvald, Anthony J., Feaster, Toby D., Weaver, Curtis J. 2006. "[Magnitude and Frequency of Rural Floods in the Southeastern United States, 2006](#):" Volume 1, Georgia," U.S. Geological Survey Scientific Investigations Report 2009-5043.
8. Ho, Francis P. (1974). "[Storm Tide Frequency Analysis for the Coast of Georgia](#)". NOAA Technical Memorandum NWS Hydro-19. Office of Hydrology, Silver Spring, MD.
9. Lagasse, P.F., Clopper, P.E., Pagan-Ortiz, J.E., Zevenbergen, L.W., Arneson, L.A., Schall, J.D., Girard, L.G. 2009, Bridge Scour and Stream Instability Countermeasures, [Hydraulic Engineering Circular No. 23](#), FHWA-NHI-09-111. Federal Highway Administration (FHWA), U.S. Department of Transportation, Washington, D.C.
10. Lagasse, P.F., Zevenbergen, L.W., Spitz, W.J., Arneson, L.A. 2012, Stream Stability at Highway Structures, [Hydraulic Engineering Circular No. 20](#), FHWA-HIF-12-004. Federal Highway Administration (FHWA), U.S. Department of Transportation, Washington, D.C.
11. South Carolina Department of Transportation (SCDOT). 2009. [Requirements for Hydraulic Design Studies](#).
12. United States Army Corps of Engineers (USACE). 1982. "[Shore Protection Manual](#)", Second Printing, prepared for the Department of the Army, Washington, D.C.
13. United States Army Corps of Engineers (USACE). 2010. HEC-RAS, River Analysis System, [Hydraulic Reference Manual](#). The Hydrologic Engineering Center, Davis, CA, Version 4.1

Chapter 13. Bridge Deck Drainage Systems - Contents

Chapter 13. Bridge Deck Drainage Systems - Contents.....	13-i
13.1 Introduction.....	13-1
13.2 Design Guidelines	13-1
13.2.1 General Design Criteria.....	13-1
13.2.2 Design Spread and Frequency.....	13-2
13.2.3 Bridge Deck Drainage Systems	13-2
13.3 Information Needed for Design.....	13-3
13.4 Design Methods and Procedures	13-3
13.5 Typical Deck Drain Details Used by GDOT.....	13-4
13.6 Analysis of Circular Scuppers.....	13-6
Chapter 13 References.....	13-8

Chapter 13. Bridge Deck Drainage Systems

13.1 Introduction

Bridge deck drainage is similar to that for a curbed roadway section. It can be less efficient because deck cross slopes are flatter, parapets collect large amounts of debris, and small drainage inlets or scuppers have a higher potential for clogging due to debris.

Because of the difficulties in providing and maintaining an adequate deck drainage system, gutter flow from the roadway should be intercepted before it reaches a bridge. Intercepted runoff should be collected by means of inlets and conveyed within a storm sewer system to the proper stable designed outlet. For minimal intercepted flow, gutter turnouts may be used to direct the runoff to an adjacent road side ditch.

The bridge deck drainage system should be designed to convey water and keep it from contacting the structural components of the bridge in order to prevent deterioration from runoff pollutants. In addition, for sensitive watershed areas, runoff should be handled in compliance with the applicable stormwater quality MS4 regulations referenced in chapter 10 of this manual.

13.2 Design Guidelines

FHWA Hydraulic Engineering Circular No. 21 (HEC-21), *Design of Bridge Deck Drainage*, May 1993, [\(13-2\)](#) should be referenced for bridge deck drainage design procedures and example problems. The following is a summary of design guidelines for bridge deck drainage systems that are specific to GDOT.

13.2.1 General Design Criteria

The designer should follow the basic rules listed below to eliminate and/or minimize bridge deck drainage problems.

- Superelevation transitions, flat grades, and sag vertical curves shall be avoided wherever possible on bridges. The minimum desirable longitudinal grade for bridge deck drainage is 0.5%.
- Gutter flow drainage from the upslope roadway shall be collected before it reaches the bridge deck.
- Runoff from bridge decks shall be collected immediately after it flows onto the subsequent roadway section where larger grates and inlet structures can be used.
- Adequate cross slope must be provided so that water flows quickly toward the drain. The desirable minimum cross slope for bridges with a normal crown is 2%. In the coastal region of Georgia, where intense rainfall is more frequent, a steeper cross slope of 2.5% may be more desirable to facilitate drainage for a two lane facility. Where three or more travel lanes are provided in each direction, the maximum pavement cross slope may be increased to 3%.

- Ideally, the longitudinal slope of the bridge deck should be steep enough to satisfy the gutter-spread requirements without the need for scuppers or a closed conveyance system on the structure.
- For long span bridges, it is desirable to set the proposed profile in a crest vertical curve with the high point occurring in the center of the bridge.

13.2.2 Design Spread and Frequency

Criteria for design spread and frequency are listed below:

- The Rational Method shall be used for computing runoff for bridge decks.
- The spread of gutter flow during the design storm shall be limited to the shoulder area to avoid encroachment into the traffic lane for a bridge facility, if possible.
- Where speed limits are 45 mph or less, gutter flow may encroach into the outermost travel lane so long as at least 10 feet of the outermost lane remains open.

See chapter 12 for more information.

13.2.3 Bridge Deck Drainage Systems

The standard bridge deck drainage system used by the GDOT is the placement of 4-inch diameter open deck drains through the bridge deck along the face of the barrier or sidewalk curb (see section 13.5 of this manual).

If factors, such as the location of the bridge beam, prevent the standard deck drains from being used, the alternate system is placing 3-inch high by 6-inch wide deck drains through the barrier (see section 13.5).

The following guidelines are used in the placement of the above standard and alternate deck drainage systems:

- The deck drains shall be spaced at 10-foot intervals along both sides of the bridge for normal crowns, and along the low side of the bridge for decks with constant cross slopes and superelevation. The deck drains should be omitted over bridge endrolls. The deck drain spacing shall begin at 5 feet from the centerline of the intermediate bents.
- Special consideration shall be given to drain spacing on structures with reverse horizontal curves occurring on the bridge. Sufficient drain openings shall be provided to minimize "cross flow" onto traffic lanes at superelevation transition areas.
- Deck drainage shall not be allowed to fall onto railroad beds, roadways, and ESAs. An ESA may typically be or include wetlands, intracoastal waterways, the presences of endangered species, cultural areas, historical areas, 303(d) listed impaired streams, or MS4 permitted areas. ESAs will be identified in the project Ecology Assessment of Effects Report provided by GDOT's Division of Engineering, Office of Environmental Services. ESAs are also identified by History and Archaeology Assessment of Effects Reports ("cultural areas").
- For bridges where standard deck drains are not allowed but supporting calculations indicate that inlets are required on the bridge, coordinate with the roadway designer to adjust the grade or cross slope to eliminate the need for inlets on the bridge. If deck drains cannot be

eliminated from the bridge due to excessive structure length or width, superelevation, or narrow shoulders, a closed drainage system shall be required.

- In cases where the bridge is very long and deck drainage is needed, a closed storm drain system shall be used to direct surface water runoff to a stabilized outlet, unless advised otherwise by GDOT.

A closed system should consist of vertical drains with steel grate inlets on the bridge deck with polyvinyl chloride (PVC) pipe to transport the water to a collector. The bridge hydraulics engineer will determine the size and spacing of the deck drains and associated closed drainage system, and will work with the structural engineer to maintain structural integrity of the design. A typical vertical inlet deck drain system is shown in Figure 13.4.

13.3 Information Needed for Design

- Preliminary proposed roadway plans
- Preliminary bridge layout
- FHWA HEC-21
- Catalog of suppliers on List 11 of the GDOT Qualified Products List, "*Foundries Supplying Gray Iron Drainage Castings.*" [\(13-1\)](#)

13.4 Design Methods and Procedures

Design Methods and procedures follow:

- The roadway engineer should consider drainage early in the design phase. By avoiding superelevation transition, flat grades, and sag vertical curves on bridges, inlets on bridges can often be eliminated. Adequate cross slope shall be provided on the bridge section so that the water flows quickly toward the drain.
- The roadway engineer shall calculate the gutter flow drainage from the upslope roadway using the Rational Method as shown in chapter 6, *Pavement Drainage*.
- The roadway engineer shall place and size one or more drainage structures to collect the gutter flow drainage from the upslope roadway before it reaches the bridge deck. See chapter 6 of this manual.
- The bridge hydraulics engineer shall determine if the standard bridge deck drain systems described in section 13.2.3 are adequate. **The engineer shall take into account that bridges located over MS4 permit areas, railroads, roadways, and other sensitive features may not have any open deck drains incorporated into the structure.**
- The roadway designer shall place and size one or more drainage structures to collect runoff from the bridge deck immediately after it flows onto the subsequent roadway section (see chapter 6 of this manual).
- If the bridge hydraulics engineer determines that the standard open deck drains are inadequate for the bridge, the methods in HEC-21 shall be used to size an adequate deck drain system. A catalog from an approved supplier should be used to select a bridge drain

system that will be satisfactory both hydraulically and structurally. The bridge hydraulics engineer and bridge structural engineer shall meet and decide, on a case-by-case basis, which deck drain system is the best for the bridge.

- Special design deck drain systems and closed conveyance systems (as in the process above) should be designed to transport the water to a collector utilizing PVC pipe.
- For runoff discharge criteria, the bridge hydraulics engineer should refer to chapter 10 of this manual regarding the use of scuppers within an MS4 area.

13.5 Typical Deck Drain Details Used by GDOT

The following four figures shown on the next pages are the typical GDOT deck drain details used for most general design applications. Please coordinate with the GDOT bridge hydraulics engineer for guidance on other types of specific deck drain design applications.

Figure 13.1 - Four-inch diameter open deck drain detail at barrier

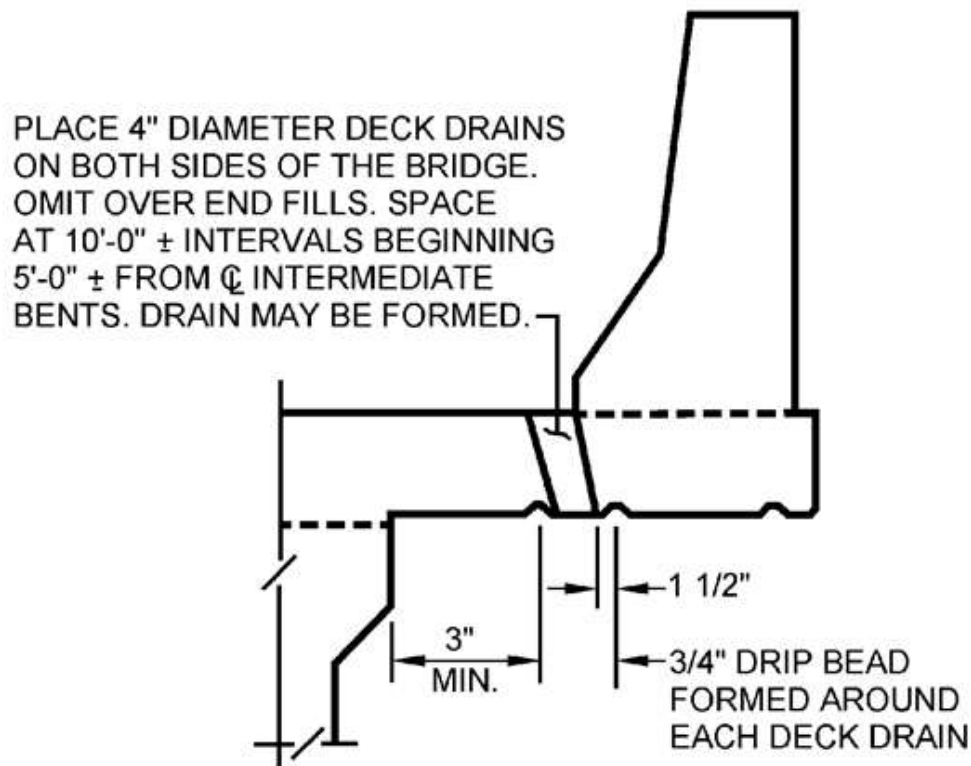

Figure 13.2 - Four-inch diameter open deck drain detail at sidewalk

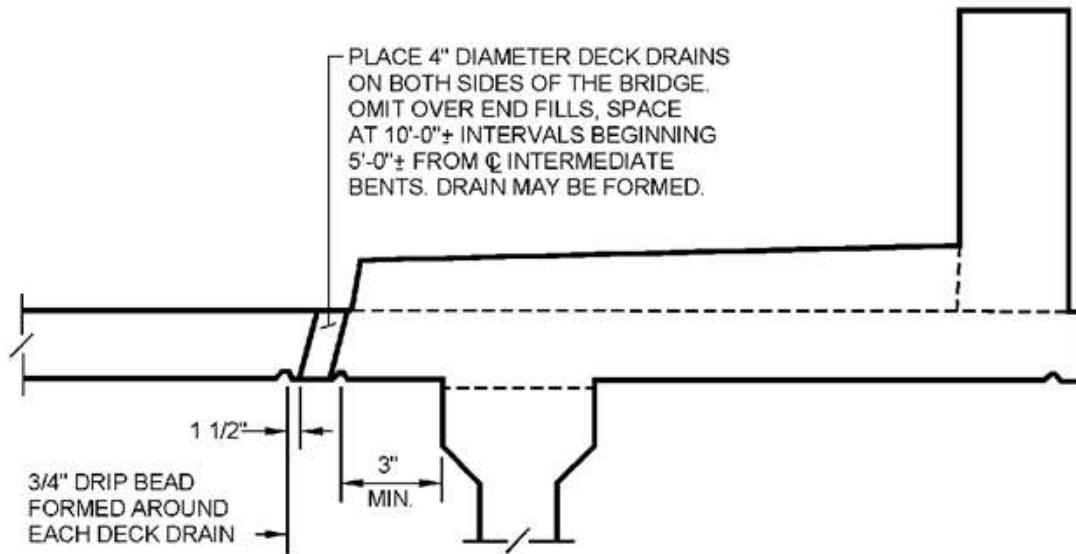

Figure 13.3 - Three-inch by six-inch open deck drain detail through barrier

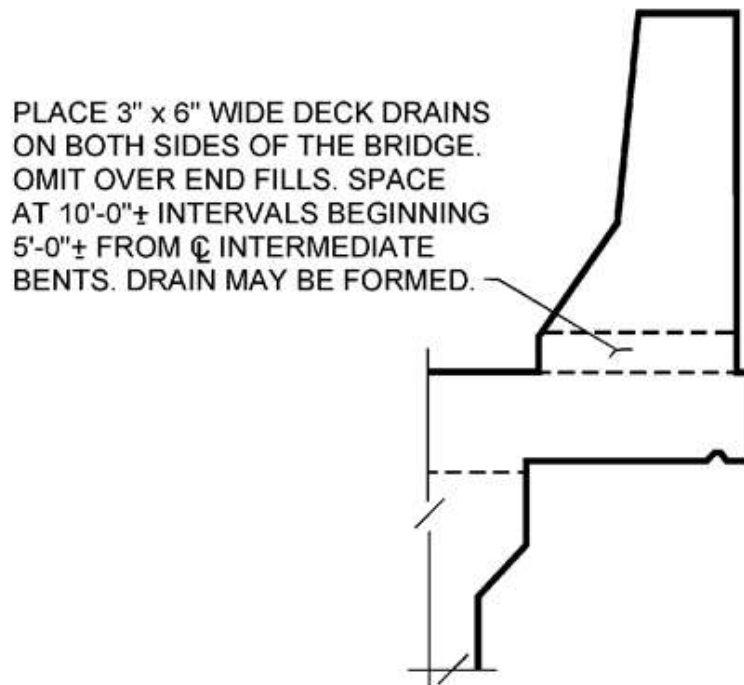
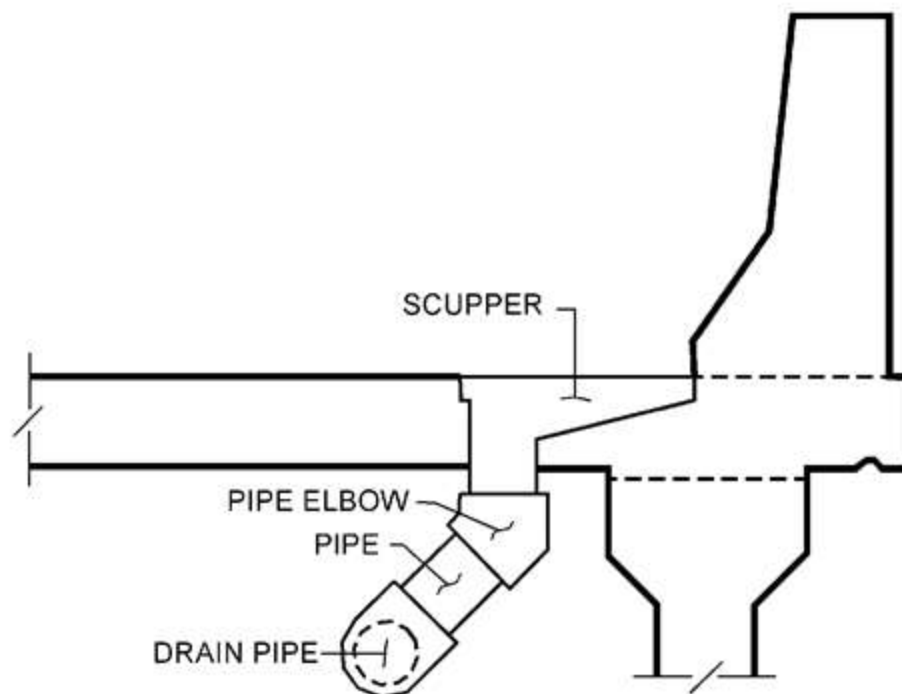

Figure 13.4 - Closed conveyance deck drain system



13.6 Analysis of Circular Scuppers

The flow in circular scuppers can be estimated using Equation 6.12 provided in chapter 6, which is included as follows for convenience:

$$Q_i = EQ \quad (6.12)$$

Where:

Q_i = Flow intercepted by the circular scupper inlet, ft³/s

E = Efficiency

Q = Flow in the gutter for a given width of spread, ft³/s

The efficiency (E) of circular scuppers to be used with Equation 6.12 is given by Figure 13.5.

Figure 13.5 - Efficiency curves for circular scuppers (13-2)

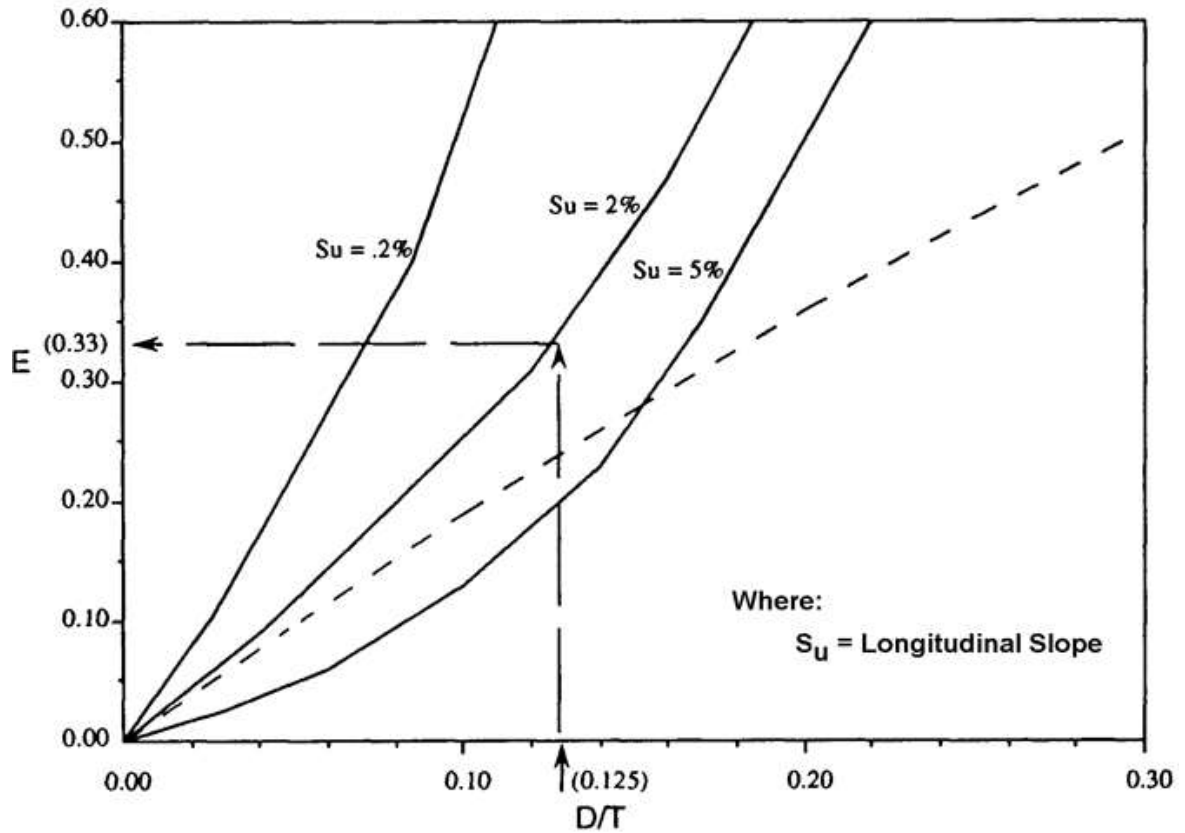

KEY

- Empiric curves based on laboratory data by Anderson, 1973
- - - - 100% of frontal flow area of width, D

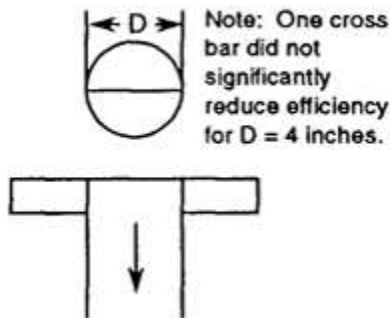
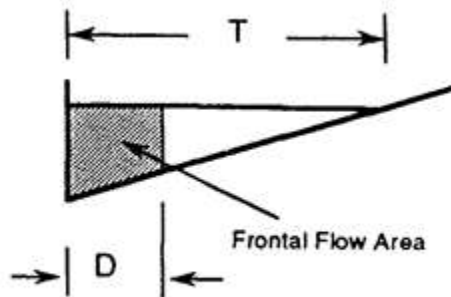

EXAMPLE	
Given:	$D = 6 \text{ in.}; T = 4 \text{ ft.}$ $S_u = 2\%$
Then:	$D/T = .125$ $E = 0.33$

Chapter 13 References

1. Georgia Department of Transportation (GDOT). [Qualified Products List](#).
2. Young, G.K, Walker, S.E., Chang, F. 1993, Design of Bridge Deck Drainage, [Hydraulic Engineering Circular No. 21](#), FHWA-SA-92-010. Federal Highway Administration (FHWA), U.S. Department of Transportation, Washington, D.C.

Appendix A. Acronyms

A list of stormwater management terms used for state highways is provided below:

AASHTO	American Association of State Highway Transportation Officials
ACPA	American Concrete Pipe Association
ADT	Average Daily Traffic
AHW	Allowable Headwater
AOP	Aquatic Organism Passage
ARC	Atlanta Regional Commission
ASTM	American Society for Testing and Materials
BFI	Bridge Foundation Investigation
BMP	Best Management Practice / structural device used to treat or detain stormwater runoff
BOD	Biological Oxygen Demand
CAD	Computer-Aided Design (software)
CE	Categorical Exclusion
CFR	Code of Federal Regulations
CLOMR	Conditional Letter of Map Revision
CN	Curve Number
CPESC	Certified Professional in Erosion and Sediment Control
CSS	Coastal Stormwater Supplement
CWA	Clean Water Act
DFIRM	Digital Flood Insurance Rate Maps
DNR	Department of Natural Resources
DTM	Digital Terrain Model
EA	Environmental Assessment
ED	Extended Detention
EGL	Energy Grade Line
EIS	Environmental Impact Statement
EPA	Environmental Protection Agency (Federal)
EPD	GaDNR Environmental Protection Division
EPM	Environmental Procedures Manual

ESA	Environmental Site Assessment
ESPCP	Erosion, Sedimentation, and Pollution Control Plans
EST	Empirical Simulation Technique
FEIS	Final Environmental Impact Statement
FEMA	Federal Emergency Management Agency
FHWA	Federal Highway Administration
FFPR	Final Field Plan Review
FIRM	Flood Insurance Rate Map
FIS	Flood Insurance Studies
FS	Factor of Safety
GADNR	Georgia Department of Natural Resources
GDOT	Georgia Department of Transportation
GDR	Geotechnical Data Report
GEPA	Georgia Environmental Protection Act
GI	Green Infrastructure
GIS	Geographic Information System
GPS	Global Positioning System
GSMM	Georgia Stormwater Management Manual
GSWCC	Georgia Soil and Water Conservation Commission
HDS	Hydraulic Design Series
HGL	Hydraulic Grade Line
HSG	Hydrologic Soil Group
HW	Headwater
IDF	Intensity-Duration-Frequency
LCI	Land Cover Institute
LIA	Local Issuing Authority
LID	Low Impact Development
LIDAR	Light Detection and Ranging
LOMR	Letter of Map Revision
LRFD	Load and Resistance Factor Design
LTAP	Local Technical Assistance Program
MDM	Model Drainage Manual

MEP	Maximum Extent Practicable
MNGWPD	Metropolitan North Georgia Water Planning District
MS4	Municipal Separate Storm Sewer Systems
MSL	Mean Sea Level
NAVD	North American Vertical Datum
NEPA	National Environmental Protection Act
NFIP	National Flood Insurance Program
NGS	National Geodetic Survey
NGVD	National Geodetic Vertical Datum
NOAA	National Oceanic and Atmospheric Administration
NOI	Notice of Intent
NPDES	National Pollutant Discharge Elimination System
NRCS	Natural Resources Conservation Service
NWP	Nationwide Permit
O&M	Operation and Maintenance
OCGA	Official Code of Georgia Annotated
ODPS	GDOT Office of Design Policy and Support
OES	Office of Environmental Services
OGFC	Open Graded Friction Course
OMAT	GDOT Office of Materials and Testing
P-Index	Phosphorus Index
PAR	Practical Alternatives Report
PDF	Portable Document Format
PE	Professional Engineer
PEM	Porous European Mix
PCN	Pre-Construction Notification
PDP	Plan Development Process
PFPR	Preliminary Field Plan Review
PGD	Pea Gravel Diaphragm
PI	Plasticity Index
PI	Point of Intersection
PM	Office of Program Delivery Project Manager

PPG	Plan Presentation Guide
PSC	Prestressed Concrete
PVC	Polyvinyl Chloride
PVI	Point of Vertical Intersection
QA	Quality Assurance
QC	Quality Control
RCP	Reinforced Concrete Pipe
RGP	Regional General Permit
ROW	Right-of-Way
SCS	Soil Conservation Service
SDH	Single Design Hydrograph
TMDL	Total Maximum Daily Load
TN	Total Nitrogen
TP	Total Phosphorus
TRM	Turf Reinforcement Mat
TSS	Total Suspended Solids
TVA	Tennessee Valley Authority
TW	Tailwater
UFC	Unified Facilities Criteria
USACE	United States Army Corps of Engineers
USBR	U.S. Bureau of Reclamation
USCS	Unified Soil Classification System
USDA	United States Department of Agriculture
USFS	United States Forest Service
USGS	United States Geological Survey
USFWS	United States Fish and Wildlife Service
UST	Underground Storage Tank
VPD	Vehicles per Day
WECS	Worksite Erosion Control Supervisor
WQ	Water Quality

Appendix B. FEMA Agency Coordination, Regulations, and Documentation

Section 1 – Federal-Aid Policy Guide

FEDERAL-AID POLICY GUIDE

September 30, 1992, Transmittal 5

NS 23 CFR 650A

Attachment 2

NON-REGULATORY SUPPLEMENT ATTACHMENT

OPI:HNG-31

PROCEDURES FOR COORDINATING HIGHWAY ENCROACHMENTS ON FLOODPLAINS WITH FEDERAL EMERGENCY MANAGEMENT AGENCY (FEMA)

The local community with land use jurisdiction, whether it is a city, county, or State, has the responsibility for enforcing National Flood Insurance Program (NFIP) regulations in that community if the community is participating in the NFIP. Most NFIP communities have established a permit requirement for all development within the base (100 year) floodplain. Consistency with NFIP standards is a requirement for Federal-aid highway actions involving regulatory floodways. The community, by necessity, is the one who must submit proposals to FEMA for amendments to NFIP ordinances and maps in that community should it be necessary. Determination of the status of a community's participation in the NFIP and review of applicable NFIP maps and ordinances are, therefore, essential first steps in conducting location hydraulic studies and preparing environmental documents.

Where NFIP maps are available, their use is mandatory in determining whether a highway location alternative will include an encroachment on the base floodplain. Three types of NFIP maps are published: (1) a Flood Hazard Boundary Map (FHBM), (2) a Flood Boundary and Floodway Map (FBFM), and a Flood Insurance Rate Map (FIRM). A FHBM is generally not based on a detailed hydraulic study and, therefore, the floodplain boundaries shown are approximate. A FBFM, on the other hand, is generally derived from a detailed hydraulic study and should provide reasonably accurate information. The hydraulic data from which the FBFM was derived is available through the regional office of FEMA. This is normally in the form of computer input data cards for calculating water surface profiles. The FIRM is generally produced at the same time using the same hydraulic model and has appropriate rate zones and base flood elevations added.

Communities in the regular program of the NFIP generally have had detailed flood insurance studies performed. In these communities the NFIP map will be a FIRM and in the majority of cases, a regulatory floodway is in effect.

Communities in the emergency program of the NFIP usually have not had a detailed flood insurance study completed and, usually, only limited floodplain data is available. In this case the community NFIP map will be a FHBM and there will not be a regulatory floodway.

Other possibilities are: (1) the community is not in a FEMA identified flood hazard area and thus there is no NFIP map, (2) a FHBM, FIRM, or FBFM is available but the community is not participating in the NFIP, (3) a community is in the process of converting from the emergency program to the regular program and a detailed flood insurance study is underway, or (4) a community is participating in the regular program, the NFIP map is a FIRM, but no regulatory floodway has been established. Information on community participation in the NFIP is provided in the "National Flood Insurance Program Community Status Book" which is published bi-monthly for each State and is available through the Headquarters of FEMA.

Coordination With FEMA

It is intended that there should be highway agency coordination with FEMA in situations where administrative determinations are needed involving a regulatory floodway or where flood risks in NFIP communities are significantly impacted. The circumstances which would ordinarily require coordination with FEMA are:

1. A proposed crossing encroaches on a regulatory floodway and, as such, would require an amendment to the floodway map,
2. A proposed crossing encroaches on a floodplain where a detailed study has been performed but no floodway designated and the maximum 1 foot increase in the base flood elevation would be exceeded,
3. A local community is expected to enter into the regular program within a reasonable period and detailed floodplain studies are underway,
4. A local community is participating in the emergency program and base flood elevation in the vicinity of insurable buildings is increased by more than 1 foot. (Where insurable buildings are not affected, it is sufficient to notify FEMA of changes to base flood elevations as a result of highway construction.)

The draft EIS/EA should indicate the NFIP status of affected communities, the encroachments anticipated and the need for floodway or floodplain ordinance amendments. Coordination means furnishing to FEMA the draft EIS/EA and, upon selection of an alternative, furnishing to FEMA through the community a preliminary site plan and water surface elevation information and technical data in support of a floodway revision request as required. If a determination by FEMA would influence the selection of an alternative, a commitment from FEMA should be obtained prior to the FEIS or FONSI. Otherwise this later coordination may be postponed until the design phase.

For projects that will be processed with a categorical exclusion, coordination may be carried out during design. However, the outcome of the coordination at this time could change the class of environmental processing.

Highway Encroachments Which Are Consistent With Regulatory Floodways In Effect

In many situations it is possible to design and construct highways in a cost-effective manner such that their components are excluded from the floodway. This is the simplest way to be consistent with the standards and should be the initial alternative evaluated. If a project element encroaches on the floodway but has a very minor effect on the floodway water surface elevation (such as piers in the floodway), the project may normally be considered as being consistent with the standards if

hydraulic conditions can be improved so that no water surface elevation increase is reflected in the computer printout for the new conditions.

Revision of Regulatory Floodway So That Highway Encroachment Would Be Consistent

Where it is not cost-effective to design a highway crossing to avoid encroachment on an established floodway, a second alternative would be a modification of the floodway itself. Often, the community will be willing to accept an alternative floodway configuration to accommodate a proposed crossing provided NFIP limitations on increases in the base flood elevation are not exceeded. This approach is useful where the highway crossing does not cause more than a 1 foot rise in the base flood elevation. In some cases, it may be possible to enlarge the floodway or otherwise increase conveyance in the floodway above and below the crossing in order to allow greater encroachment. Such planning is best accomplished when the floodway is first established. However, where the community is willing to amend an established floodway to support this option, the floodway may be revised.

The responsibility for demonstrating that an alternative floodway configuration meets NFIP requirements rests with the community. However, this responsibility may be borne by the agency proposing to construct the highway crossing. Floodway revisions must be based on the hydraulic model which was used to develop the currently effective floodway but updated to reflect existing encroachment conditions. This will allow determination of the increase in the base flood elevation that has been caused by encroachments since the original floodway was established. Alternate floodway configurations may then be analyzed.

Base flood elevation increases are referenced to the profile obtained for existing conditions when the floodway was first established.

Data submitted to FEMA in support of a floodway revision request should include:

1. Copy of current regulatory Flood Boundary Floodway Map, showing existing conditions, proposed highway crossing and revised floodway limits.
2. Copy of computer printouts (input, computation, and output) for the current 100-year model and current 100-year floodway model.
3. Copy of computer printouts (input, computation, and output) for the revised 100-year floodway model. Any fill or development that has occurred in the existing flood fringe area must be incorporated into the revised 100-year floodway model.
4. Copy of engineering certification is required for work performed by private subcontractors.

The revised and current computer data required above should extend far enough upstream and downstream of the floodway revision area in order to tie back into the original floodway and profiles using sound hydraulic engineering practices. This distance will vary depending on the magnitude of the requested floodway revision and the hydraulic characteristics of the stream.

A floodway revision will not be acceptable if development that has occurred in the existing flood fringe area since the adoption of the community's floodway ordinance will now be located within the revised floodway area unless adversely affected adjacent property owners are compensated for the loss. If the input data representing the original hydraulic model is unavailable, an approximation should be developed. A new model should be established using the original cross-section topographic information, where possible, and the discharges contained in the Flood Insurance

Study which establish the original floodway. The model should then be run confining the effective flow area to the currently established floodway and calibrate to reproduce within 0.10 foot, the "With Floodway" elevations provided in the Floodway Data Table for the current floodway. Floodway revisions may then be evaluated using the procedures outlined above.

Floodway Encroachment Where Demonstrably Appropriate

When it would be demonstrably inappropriate to design a highway crossing to avoid encroachment on the floodway and where the floodway cannot be modified such that the structure could be excluded, FEMA will approve an alternate floodway with backwater in excess of the 1 foot maximum only when the following conditions have been met:

1. A location hydraulic study has been performed in accordance with "Location and Hydraulic Design of Encroachments on Floodplains" (23 CFR 650, Subpart A) and FHWA finds the encroachment is the only practicable alternative.
2. The constructing agency has made appropriate arrangements with affected property owners and the community to obtain flooding easements or otherwise compensate them for future flood losses due to the effects of the structure.
3. The constructing agency has made appropriate arrangements to assure that the National Flood Insurance Program and Flood Insurance Fund do not incur any liability for additional future flood losses to existing structures which are insured under the Program and grandfathered in under the risk status existing prior to the construction of the structure.
4. Prior to initiating construction, the constructing agency provides FEMA with revised flood profiles, floodway and floodplain mapping, and background technical data necessary for FEMA to issue revised Flood Insurance Rate Maps and Flood Boundary and Floodway Maps for the affected area upon completion of the structure.

Highway Encroachment On A Floodplain With A Detailed Study (FIRM) In communities where a detailed flood insurance study has been performed but no regulatory floodway designated, the highway crossing should be designed to allow no more than a 1 foot increase in the base flood elevation based on technical data from the flood insurance study. Technical data supporting the increased flood elevation should be submitted to the local community and FEMA for their files. Where it is demonstrably inappropriate to design the highway crossing and meet backwater limitations the procedures outlined under:

Floodway Encroachment Where Demonstrably Appropriate should be followed in requesting a revision of base floodplain reference elevations.

Highway Encroachment On A Floodplain Indicated On An FHBM

In communities where detailed flood insurance studies have not been performed, the highway agency must generate its own technical data to determine the base floodplain elevation and design encroachments in accordance with 23 CFR 650A. Base floodplain elevations should be furnished to the community, and coordination carried out with FEMA as outlined previously where the increase in base flood elevations in the vicinity of insurable buildings exceeds 1 foot.

Highway Encroachment On Unidentified Floodplains

Encroachments which are outside of NFIP communities or NFIP identified flood hazard areas should be designed in accordance with 23 CFR 650A of the Federal Highway Administration. The NFIP identified flood hazard areas are those delineated on an FHBM, FBFM or FIRM.

To Obtain FEMA Publications

1. National Flood Insurance Program Community Status Book

Write to FEMA, 500 "C" Street, SW., Room 431, Insurance Operations, Washington, D.C. 20472 and request to be placed on the appropriate State mailing list.

2. Flood Insurance Study Report and/or FBFM

Write to FEMA, 500 "C" Street, SW., State and Local Programs Room 418, Washington, D.C. 20472 request:

(a) For future studies,

To be placed on mailing list to receive all studies and maps as they are completed for a State.

(b) For completed studies,

- (1) The study for a particular community (provide number).
- (2) All the studies for a particular State. You will receive about 50% of the completed studies to date.

3. FHBM or FIRM for a particular community with ID number,

- (a) Call NFIP contractor (800) 638-6620, (800) 492-6605(MD), 897-5900 in D.C., or
- (b) Write NFIP, P.O. Box 34604, Bethesda, Maryland 20034.

United States Department of Transportation - **Federal Highway Administration**

Briefing FHWA/FEMA Coordination Procedures

The procedures divide highway encroachments on floodplains into six categories:

1. Consistent with a Regulatory Floodway (RFW)

- a. Applicable to 5,000 communities (county or city) which are in the FEMA regular flood insurance program
- b. Community prohibits development in RFW, but allows development that is flood proofed in fringe

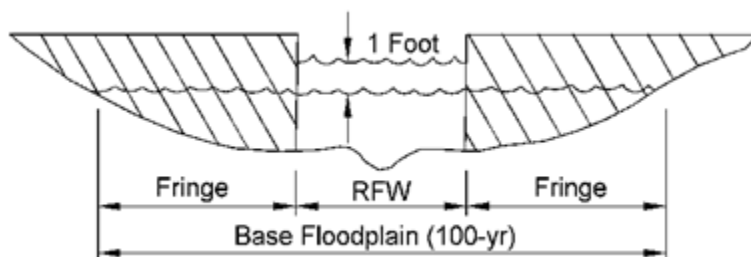

- c. Highways are consistent by not increasing backwater
 - (1) Bridging RFW and
 - (2) Excluding fill from RFW

2. Consistent by Revision of RFW

- a. Same as 1
- b. Same as 1
- c. Same as 1
- d. If community and FEMA agree, RFW can be shifted

3. On RFW where demonstrably appropriate

- a. Same as 1
- b. Same as 1
- c. Highways can increase backwater if:
 - (1) Little or no risk to development can be demonstrated, and
 - (2) Community and FEMA concur

4. On floodplain shown on Flood Insurance Rate Map (FIRM)

- a. Applicable to 2,000 communities in regular insurance program
- b. No RFW has been developed, but flood elevations have
- c. Community controls development within FIRM
- d. Highway encroachment should cause less than 1 foot of backwater

5. On floodplain shown on Flood Hazard Boundary Map (FHBM)

- a. Applicable to 13,000 communities, 10,000 in emergency insurance program
- b. No RFW or flood elevations have been developed
- c. Community controls development within FHBM
- d. Highway encroachment should cause less than 1 foot of backwater if insurable buildings are present

6. On unidentified floodplains

- a. Floodplain is not shown on FIRM or FHBM

- b. Floodplain is therefore outside of the 20,000 flood prone areas in the U.S. that are of concern of FEMA
- c. Apply FHPM 6-7-3-2, Location and Hydraulic Design of Encroachments on Floodplains

Section 2 - Definitions of NFIP Terminology

Frequently used terms related to NFIP compliance are defined below.

The **BASE FLOOD** is the flood having a 1% chance of being equaled or exceeded in a given year. This is often referred to as the 100-year flood.

The **BASE FLOOD ELEVATION** is the water surface elevation at a given location associated with the base flood.

The **BASE FLOOD PROFILE** is the water surface profile along a stream associated with the base flood.

The **COMMUNITY** is the local entity (city or county government) with jurisdiction for floodplain administration under the NFIP.

A **CONDITIONAL LETTER OF MAP REVISION (CLOMR)** is a letter issued by FEMA that approves a proposed project. The letter states that the project will result in the specified changes to the base flood elevations, floodway elevations, floodplain limits, and floodway boundaries if constructed as shown. The request for a CLOMR is made by the Community.

An **ENCROACHMENT** in the context of this manual is a placement of embankment fill or structure within the floodplain and/or floodway so as to affect or alter flow conditions.

A **FLOOD INSURANCE RATE MAP (FIRM)** is an official map of a community showing the delineation of the area Special Flood Hazard Area, along with insurance risk premium zones applicable to the community. Some FIRM's include contours of the Base Flood Elevations in areas where detailed hydraulic studies have been made.

The **FLOODPLAIN** is the land area inundated by the base flood. Also referred to as the **SPECIAL FLOOD HAZARD AREA (SFHA)**.

The **FLOODWAY** is a portion of the floodplain that must be reserved in order to prevent activities that would cumulatively cause an increase in the base flood profile of more than a designated height. The designated height is never more than a foot, but in some communities can be less than a foot. Also referred to as the **REGULATORY FLOODWAY** or **DESIGNATED FLOODWAY**. This term applies only to floodplains within which a floodway has been officially established.

The **FLOODWAY FRINGE** is the portion of the floodplain that lies outside of the floodway. This term applies only to floodplains within which a floodway has been officially established.

A **LETTER OF MAP REVISION (LOMR)** is a letter issued by FEMA that revises the base flood elevations, floodway elevations, floodplain limits, and floodway boundaries for a given stream reach, based on documentation of changed or updated physical conditions. The request for a LOMR is made by the Community.

A **NO-RISE certificate** is a document submitted to the Community, with attached hydraulic computations, affirming that the proposed encroachment will not cause an increase in the base flood profile, the floodway width, or the floodway profile. See Appendix F for a sample.

The **FLOODWAY ELEVATION** is the water surface elevation resulting from encroachment in the floodplain to the designated floodway boundaries.

Section 3 - FEMA Floodway Encroachment Figure

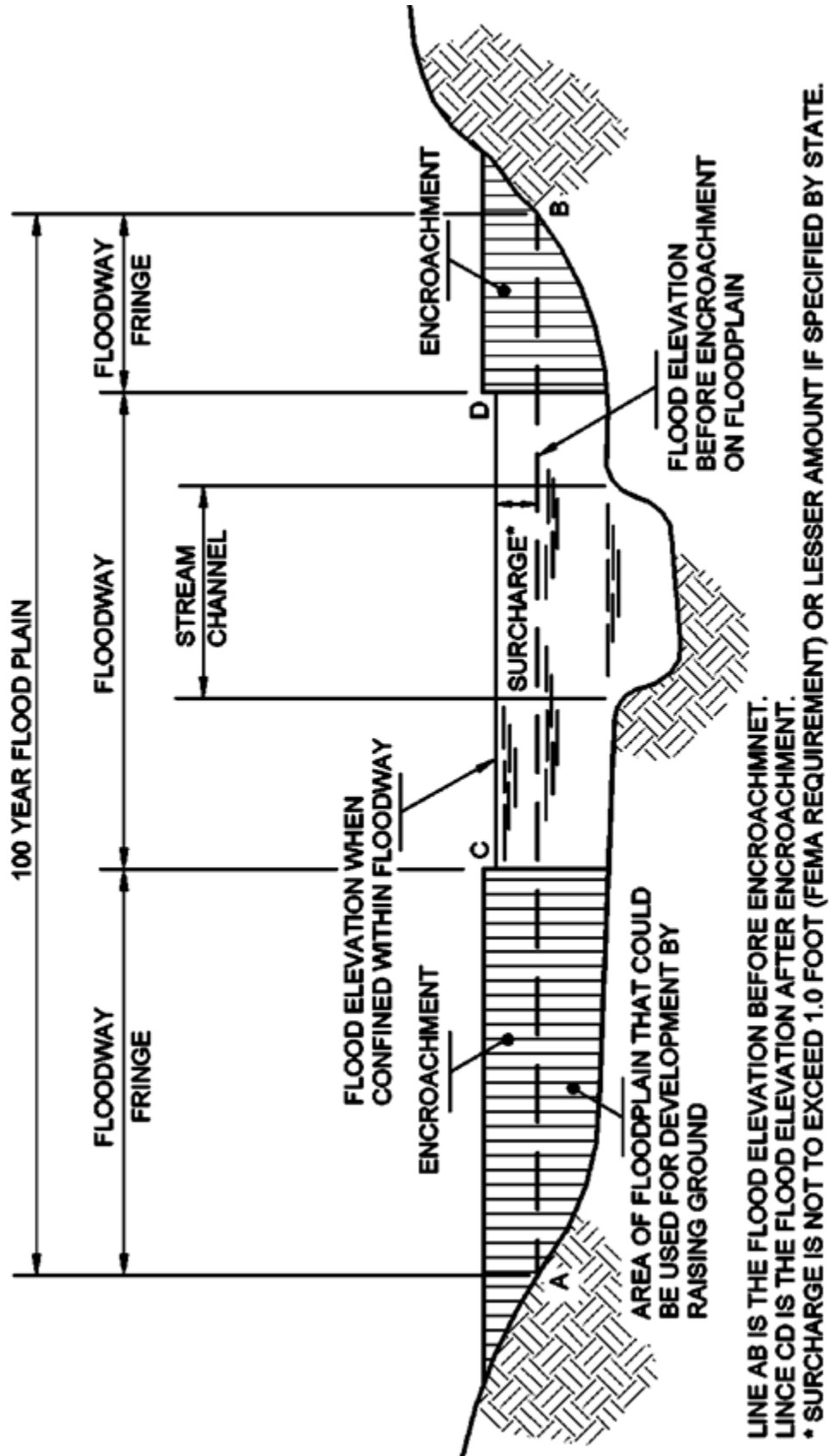

Section 4 – Sample FEMA Floodway Map

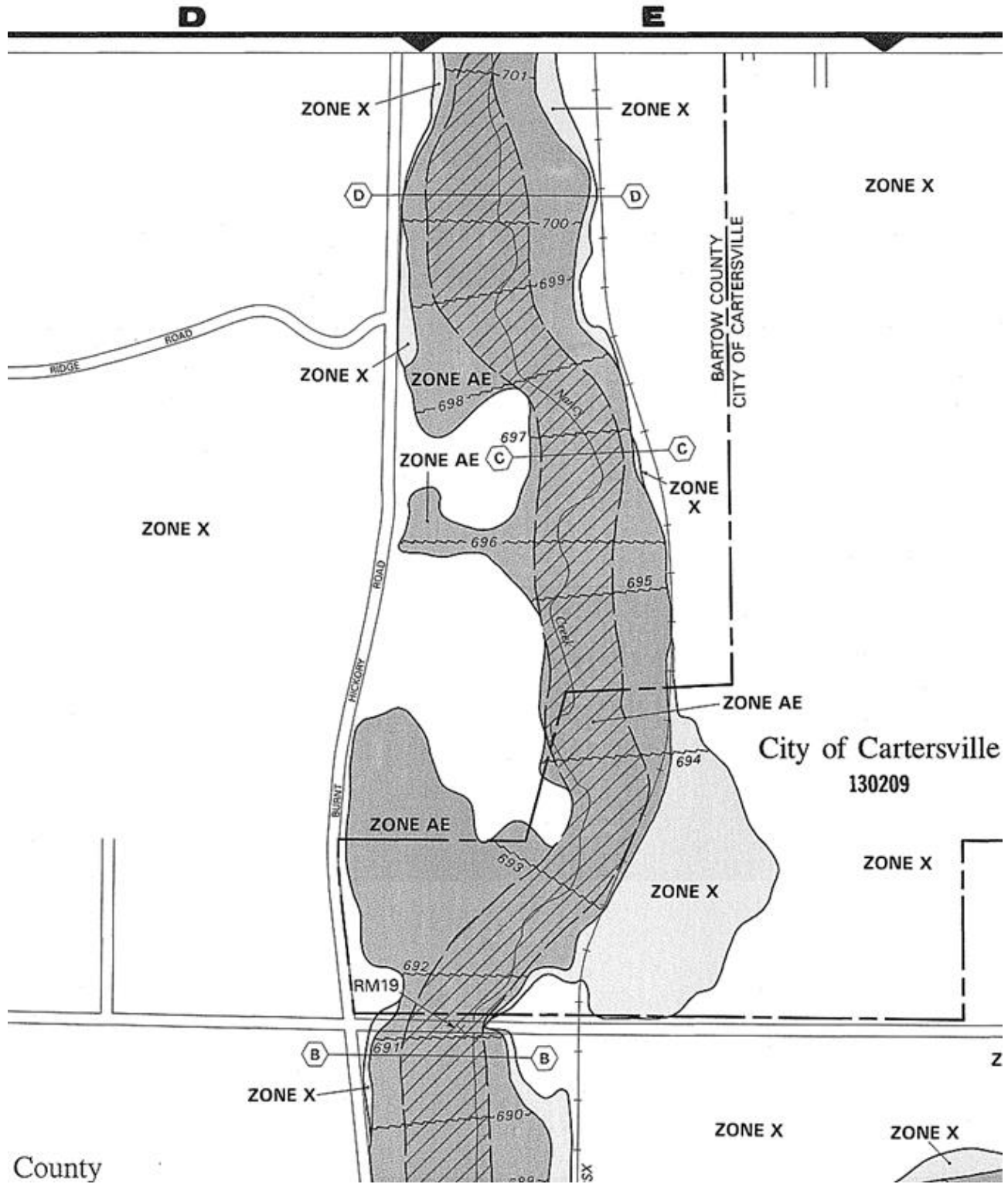

Section 5 – Sample FEMA Floodway Table

FLOODING SOURCE		FLOODWAY			BASE FLOOD WATER SURFACE ELEVATION			
CROSS SECTION	DISTANCE ¹	WIDTH (FEET)	SECTION AREA (SQ. FEET)	MEAN VELOCITY (FEET/SEC.)	REGULATORY (FEET NGVD)	WITHOUT FLOODWAY (FEET NGVD)	WITH FLOODWAY (FEET NGVD)	INCREASE (FEET)
NANCY CREEK								
A	2830	350	993	4.5	687.7	687.7	688.3	0.6
B	3750	350	1582	2.8	690.8	690.8	691.6	0.8
C	6620	329	1002	4.5	696.8	696.8	696.8	0.0
D	7900	412	1979	2.3	700.3	700.3	700.7	0.4
E	9040	141	824	5.5	702.2	702.2	702.7	0.5
F	10,400	120	921	4.9	705.7	705.7	706.4	0.7
G	11,500	282	1866	2.4	710.7	710.7	710.9	0.2
H	13,070	362	2478	1.5	712.7	712.7	713.1	0.4
I	15,040	204	649	5.9	715.2	715.2	715.2	0.0
J	16,320	567	2855	1.3	717.0	717.0	717.9	0.9
K	18,700	221	1401	2.7	726.5	726.5	726.5	0.0
L	20,450	109	490	4.5	730.2	730.2	730.8	0.6
M	22,383	360	1023	2.2	736.2	736.2	736.4	0.2
N	24,720	241	1023	2.2	743.4	743.4	744.2	0.8
O	26,800	219	725	3.0	749.4	749.4	750.0	0.6
P	27,230	200	848	2.4	752.7	752.7	752.8	0.1

¹FEET ABOVE MOUTH

FEDERAL EMERGENCY MANAGEMENT AGENCY BARTOW COUNTY, GA AND INCORPORATED AREAS	FLOODWAY DATA NANCY CREEK
---	--

TABLE 3

Section 6 – Sample No-Rise Certification Letter

Engineering "No-Rise" Certification

Chattahoochee River

Bridge Replacement

CS 613

White County, Georgia

This is to certify that I am a duly qualified engineer licensed to practice in the State of Georgia. It is to further certify that the attached technical data supports the fact that the proposed construction of the Replacement Bridge over the Chattahoochee River will not create any increase to the 100-Year flood elevations, floodway elevations, and floodway widths on the Chattahoochee River at published sections in the Preliminary Flood Insurance Study for the City of Helen, Georgia, dated October 3, 1983 and will not create any increase in 100-year flood and floodway elevations and floodway widths at unpublished cross-sections in the vicinity of the project.

DATE

SIGNATURE

SEAL:



Section 7 – Sample Letters to the Community and FEMA

GEORGIA DEPARTMENT OF TRANSPORTATION
STATE OF GEORGIA
NO. 2 CAPITOL SQUARE, S.W.
ATLANTA, GA 30334-1002

(DATE)

Project _____
PI No. _____

(Name)
City or County Manager/Engineer (Note: The appropriate Community official varies)
(Address)

Dear _____,

This project consists of the replacement of the existing 24 ft wide by 60 ft long bridge on _____ over _____ with parallel 38 ft wide by 100 ft long bridges. This site crosses the regulatory floodway established for _____ located in Unincorporated _____ County.

The required HEC-2 models along with supporting technical data for the proposed project is included in the attached documentation. The results show that the proposed construction will not increase the floodway widths or elevations from the existing conditions.

Included in this documentation for your use and files are:

1. A floodway map showing the location of the proposed site;
2. Tables showing the results of the floodway calculations;
3. A detailed explanation of the floodway calculations;
4. A preliminary bridge layout;
5. A set of roadway plans;
6. Hard copies of the required HEC-2 models; and
7. A computer disk with the required HEC-2 models.

The proposed bridge construction is consistent with the regulatory floodway at this site since the proposed construction will not increase the floodway widths or elevations from the existing conditions. In accordance with Section NS 23 CFR 650A of the Federal-Aid Policy Guide, coordination with FEMA will not be required.

A letter of concurrence from your community is required since this project crosses a regulatory floodway. Please review the enclosed information and send your letter of concurrence to this office at your earliest convenience.

This project is presently scheduled to be let to construction in _____. If you have any questions and/or comments, please contact _____ of the _____ Office at telephone number _____.

Attachments
cc:

GEORGIA DEPARTMENT OF TRANSPORTATION
STATE OF GEORGIA
NO. 2 CAPITOL SQUARE, S.W.
ATLANTA, GA 30334-1002

(DATE)

Project _____
PI No. _____

(Name)
City or County Manager/Engineer (Note: The appropriate Community official varies)
(Address)

Dear _____,

This project consists of the replacement of the existing 24 ft wide by 60 ft long bridge on _____ over _____ with a 38 ft wide by 130 ft long bridge. This site crosses the regulatory floodway established for _____ located in Unincorporated _____ County. The proposed bridge does not encroach horizontally or vertically on the existing regulatory floodway at this site.

Included in this documentation for your use and files are:

- A floodway map showing the location of the proposed site;
- The published floodway tables for the stream reach;
- A preliminary bridge layout; and
- A set of roadway plans.

Since the regulatory floodway width of 60 ft at the crossing site is cleared by the toe of endroll to toe of endroll width of the proposed 130 ft long bridge, and the 100-year floodway elevation is cleared by the proposed superstructure, there is no encroachment on the existing regulatory floodway.

The proposed bridge construction is consistent with the regulatory floodway at this site due to the bridging and excluding of fill from the existing floodway. In accordance with Section NS 23 CFR 650A of the Federal-Aid Policy Guide, coordination with FEMA will not be required.

A letter of concurrence from your community is required since this project crosses a regulatory floodway. Please review the enclosed information and send your letter of concurrence to this office at your earliest convenience.

This project is presently scheduled to be let to construction in _____. If you have any questions and/or comments, please contact _____ of the _____ Office at telephone number _____.

Attachments
cc:

GEORGIA DEPARTMENT OF TRANSPORTATION
STATE OF GEORGIA
NO. 2 CAPITOL SQUARE, S.W.
ATLANTA, GA 30334-1002

(DATE)

Project _____
PI No. _____

(Name)

City or County Manager/Engineer (Note: The appropriate Community official varies)
(Address)

Dear _____,

This project consists of the replacement of the existing 24 ft wide by 60 ft long bridge on _____ over _____ with a 38 ft wide by 130 ft long bridge. This site crosses the regulatory floodway established for _____ located in Unincorporated _____ County.

Due to several errors in the original _____ floodway run, several of the Flood Insurance Study published widths and elevations were found to be incorrect. Corrections to the original floodway model, along with the addition of four surveyed cross sections at the project site yielded the base floodway run. The proposed bridge and roadway were then inserted into the base floodway run, yielding the proposed floodway model. The results show that the proposed construction does not increase the floodway widths or elevations from the base run (corrected existing conditions).

Included in this documentation for your use and files are:

- A floodway map showing the location of the proposed site and the corrected floodway;
- The published floodway tables for the stream reach;
- Tables showing the results of the floodway calculations;
- A detailed explanation of the floodway calculations;
- A preliminary bridge layout;
- A set of roadway plans;
- Hard copies of the required floodway models; and
- A computer disk with the required floodway models.

As stated above, the results show that the published existing floodway is incorrect due to technical errors in the original model. The proposed bridge construction is consistent with the corrected regulatory floodway at this site since the proposed construction will not increase the floodway widths or elevations from the corrected existing conditions (base run). Since the proposed construction will have no impacts on the corrected existing floodway widths and elevations, in accordance with Section NS 23 CFR 650A of the Federal-Aid Policy Guide, GDOT coordination with FEMA will not be required.

A letter of concurrence from your community is required since this project crosses a regulatory floodway. Please review the enclosed information and send your letter of concurrence to this office at your earliest convenience.

This project is presently scheduled to be let to construction in _____. If you have any questions and/or comments, please contact _____ of the _____ Office at telephone number _____.

Attachments
cc:

GEORGIA DEPARTMENT OF TRANSPORTATION
STATE OF GEORGIA
NO. 2 CAPITOL SQUARE, S.W.
ATLANTA, GA 30334-1002

(DATE)

Project _____
PI No. _____

(Name)
City or County Manager/Engineer (Note: The appropriate Community official varies)
(Address)

Dear _____,

This project consists of the replacement of the existing 24 ft wide by 60 ft long bridge on _____ over _____ with a 38 ft wide by 130 ft long bridge. This site crosses the regulatory floodway established for _____ located in Unincorporated _____ County.

The proposed construction at this site increases the floodway elevations at published sections A, B and C in excess of 0.1 ft. This construction does not cause more than a 1.0 ft rise in the existing 100-year base flood elevation. The existing floodway width at section B is increased from 150 to 200 ft.

Included in this documentation for your use and files are:

1. Floodway map showing the location of the proposed site and the corrected floodway
2. Published floodway tables for the stream reach
3. Tables showing the results of the floodway calculations
4. Detailed explanation of the floodway calculations
5. Preliminary bridge layout
6. Set of roadway plans
7. Hard copies of the required floodway models
8. Computer disk with the required floodway models

Please review the enclosed documentation, and if acceptable, a letter of concurrence from your community is required since this project crosses a regulatory floodway. Please send your letter of concurrence to the Federal Emergency Management Agency with a copy to this office at your earliest convenience. FEMA's address is listed below:

_____, Regional Director
Federal Emergency Management Agency
Region IV
Mitigation Division
3003 Chamblee-Tucker Road
Atlanta, Georgia
Attn: (Regional Analyst)

This project is presently scheduled to be let to construction in _____. If you have any questions and/or comments, please contact _____ of the _____ Office at telephone number _____.

Attachments
cc:

GEORGIA DEPARTMENT OF TRANSPORTATION
STATE OF GEORGIA
NO. 2 CAPITOL SQUARE, S.W.
ATLANTA, GA 30334-1002

(DATE)

Project _____
PI No. _____

(Name), Regional Director
Federal Emergency Management Agency
Region IV
Mitigation Division
3003 Chamblee-Tucker Road
Atlanta, Georgia

Attn: (Regional Analyst)

Dear _____,

This project consists of the replacement of the existing 24 ft wide by 60 ft long bridge on _____ over _____ with a 38 ft wide by 130 ft long bridge. This site crosses the regulatory floodway established for _____ located in Unincorporated _____ County.

The proposed construction at this site increases the floodway elevations at published sections A, B and C in excess of 0.1 ft. This construction does not cause more than a 1.0 ft rise in the existing 100-year base flood elevation. The existing floodway width at section B is increased from 150 to 200 ft.

Included in this documentation for your use and files are:

1. A floodway map showing the location of the proposed site and the corrected floodway;
2. The published floodway tables for the stream reach;
3. Tables showing the results of the floodway calculations;
4. A detailed explanation of the floodway calculations;
5. A preliminary bridge layout;
6. A set of roadway plans;
7. Hard copies of the required floodway models; and
8. A computer disk with the required floodway models.

A letter of concurrence for this project from (name of affected community) has been requested.

This project is presently scheduled to be let to construction in _____. If you have any questions and/or comments, please contact _____ of the _____ Office at telephone number _____.

Attachments

cc:

Intentionally Left Blank

Appendix C. Designer's Checklist for Project Documentation

**State of Georgia
Department of Transportation**

**Designer's Checklist
For
Project Documentation**
Check All Appropriate Items

Date: _____ Design office: _____
 Project Number: _____ Consultant: _____
 County: _____ Designer: _____
 PI number: _____ Let date: _____

Reference Data

Maps

- USGS quad map
- DOT map
- Local zoning map
- Flood hazard delineation
- Floodplain delineation
- Local land use
- Soils map
- Geological map
- Aerial photos

External Agency Studies

- USACE floodplain info
- NRCS watershed studies
- Local watershed mgmt.
- USGS gages & studies
- Interim floodplain studies
- Water resource data
- Regional planning data
- Forestry service
- Utility company plans

Internal Source Studies

- Quarterly reports
- Hydraulics section records
- District drainage records
- Flood records

Hydraulic Design

Hydraulic Design

- Calibration of Highwater Data
- Discharge and frequency of highwater elevation
- Influences responsible for highwater elevation
- Analyze hydraulic performance of existing facility for minimum flow through (100 year)
- Analyze hydraulic performance of proposed facility for minimum flow through (100 year)

Design Appurtenances

- Dissipators
- Riprap
- Erosion & sediment control
- Fish & wildlife

Technical Aids

- GDOT Drainage Manual
- GDOT & FHWA directives

Computer Programs

- USACE HEC-RAS
- HY-8
- WSPRO
- Visual Urban
- HYDRAIN
- XPSWMM
- PondPack
- Culvert Master
- Flow Master
- StormCAD

Intentionally Left Blank

Appendix D. Manning's Tables

**Table 1. Manning's Roughness Coefficient (n)
for Overland Sheet Flow**

Surface Description	n
Smooth asphalt	0.011
Smooth concrete	0.012
Ordinary concrete lining	0.013
Good wood	0.014
Brick with cement mortar	0.014
Vitrified clay	0.015
Cast iron	0.015
Corrugated metal pipe	0.024
Cement rubble surface	0.024
Fallow (no residue)	0.05
Cultivated soils	
Residue cover # 20%	0.06
Residue cover > 20%	0.17
Range (natural)	0.13
Grass	
Short grass prairie	0.15
Dense grasses	0.24
Bermuda grass	0.41
Woods*	
Light underbrush	0.40
Dense underbrush	0.80

*When selecting n, consider cover to a height of about 1 inch. This is only part of the plant cover that will obstruct sheet flow.

**Table 2. Manning's Roughness Coefficients
for Various Boundaries**

Rigid Boundary Channels	Manning's n
Very smooth concrete and planed timber	
Smooth concrete	0.011
Ordinary concrete lining	0.012
Wood	0.013
Vitrified clay	0.014
Shot concrete, untroweled, and earth channels in best condition	0.015
	0.017
Straight unlined earth canals in good condition	0.020
Mountain streams with rocky beds	0.040-0.050
MINOR STREAMS (top width at flood stage < 100 ft)	
Streams on Plain	
1. Clean, straight, full stage, no rifts or deep pools	0.025-0.033
2. Same as above, but more stones and weeds	0.030-0.040
3. Clean, winding, some pools and shoals	0.033-0.045
4. Same as above, but some weeds and stones	0.035-0.050
5. Same as above, lower stages, more ineffective slopes and sections	0.040-0.055
6. Same as 4, but more stones	0.045-0.060
7. Sluggish reaches, weedy, deep pools	0.050-0.080
8. Very weedy reaches, deep pools, or floodways with heavy stand of timber and underbrush	0.075-0.150
Mountain Streams, no Vegetation in Channel, Banks Usually Steep, Trees and Brush Along Banks Submerged at High Stages	
1. Bottom: gavels, cobbles and few boulders	0.030-0.050
2. Bottom: cobbles with large boulders	0.040-0.070
Floodplains	
Pasture, No Brush	
1. Short Grass	0.025-0.035
2. High Grass	0.030-0.050
Cultivated Areas	
1. No Crop	0.020-0.040
2. Mature Row Crops	0.025-0.045
3. Mature Field Crops	0.030-0.050
Brush	
1. Scattered brush, heavy weeds	0.035-0.070
2. Light brush and trees in winter	0.035-0.060
3. Light brush and trees in summer	0.040-0.080
4. Medium to dense brush in winter	0.045-0.110
5. Medium to dense brush in summer	0.070-0.160

Table 2. Manning's Roughness Coefficients for Various Boundaries (continued).

Rigid Boundary Channels	Manning's n
Trees	
1. Dense willows, summer, straight	0.110-0.200
2. Cleared land with tree stumps, no sprouts	0.030-0.050
3. Same as above, but with heavy growth of sprouts	0.050-0.080
4. Heavy stand of timber, a few down trees, little undergrowth, flood stage below branches	0.080-0.120
5. Same as above, but with flood stage reaching branches	0.100-0.160
MAJOR STREAMS (Topwidth at flood stage > 100 ft)	
The n value is less than that for minor streams of similar description, because banks offer less effective resistance.	
Regular section with no boulders or brush	0.025-0.060
Irregular and rough section	0.035-0.100
Alluvial Sand-bed Channels (no vegetation)	
Tranquil flow, Fr < 1	
Plane bed	
Ripples	0.014-0.020
Dunes	0.018-0.030
Washed out dunes or transition	0.020-0.040
Plane bed	0.014-0.025
	0.010-0.013
Rapid Flow, Fr > 1	
Standing waves	0.010-0.015
Antidunes	0.012-0.020
Overland Flow and Sheet Flow	
Smooth asphalt	0.011
Smooth concrete	0.012
Cement rubble surface	0.024
Natural range	0.13
Dense grass	0.24
Bermuda grass	0.41
Light underbrush	0.40
Heavy underbrush	0.80

**Table 3. Values of Manning's Roughness Coefficient n
(Uniform Flow)**

Type of Channel and Description	Minimum	Normal	Maximum
EXCAVATED OR DREDGED			
Earth, straight and uniform			
Clean, recently completed	0.016	0.018	0.020
Clean, after weathering	0.018	0.022	0.025
Gravel, uniform section, clean	0.022	0.025	0.030
With short grass, few weeds	0.022	0.027	0.033
Earth, winding and sluggish			
No vegetation	0.023	0.025	0.030
Grass, some weeds	0.025	0.030	0.033
Dense weeds or aquatic plants in deep channels	0.030	0.035	0.040
Earth bottom and rubble sides	0.025	0.030	0.035
Stony bottom and weedy sides	0.025	0.035	0.045
Cobble bottom and clean sides	0.030	0.040	0.050
Dragline-excavated or dredged			
No vegetation	0.025	0.028	0.033
Light brush on banks	0.035	0.050	0.060
Rock cuts			
Smooth and uniform	0.025	0.035	0.040
Jagged and irregular	0.035	0.040	0.050
Channels not maintained, weeds and brush uncut			
Dense weeds, high as flow depth	0.050	0.080	0.120
Clean bottom, brush on sides	0.040	0.050	0.080
Same, highest stage of flow	0.045	0.070	0.110
Dense brush, high stage	0.080	0.100	0.140
NATURAL STREAMS			
Minor streams (top width at flood stage < 100 ft)			
Streams on Plain			
Clean, straight, full stage, no rifts or deep pools	0.025	0.030	0.033
Same as above, but more stones/weeds	0.030	0.035	0.040
Clean, winding, some pools/shoals	0.033	0.040	0.045
Same as above, but some weeds/stones	0.035	0.045	0.050
Same as above, lower stages, more ineffective slopes and sections	0.040	0.048	0.055
Same as 4, but more stones	0.045	0.050	0.060
Sluggish reaches, weedy, deep pools	0.050	0.070	0.080
Very weedy reaches, deep pools, or floodways with heavy stand of timber and underbrush	0.075	0.100	0.150
Mountain streams, no vegetation in channel, banks usually steep, trees and brush along banks submerged at high stages	0.030	0.040	0.050

Bottom: gravels, cobbles and few boulders	0.040	0.050	0.070
Bottom: cobbles with large boulders			

**Table 3. Values of Manning’s Roughness Coefficient n
(Uniform Flow). (continued)**

Type of Channel and Description	Minimum	Normal	Maximum
FLOODPLAINS			
Pasture, no brush			
Short grass	0.025	0.030	0.035
High grass	0.030	0.035	0.050
Cultivated area			
No crop	0.020	0.030	0.040
Mature row crops	0.025	0.035	0.045
Mature field crops	0.030	0.040	0.050
Brush			
Scattered brush, heavy weeds	0.035	0.050	0.070
Light brush and trees, in winter	0.035	0.050	0.060
Light brush and trees, in summer	0.040	0.050	0.080
Medium to dense brush, in winter	0.045	0.070	0.110
Medium to dense brush, in summer	0.070	0.100	0.160
Trees			
Dense willows, summer, straight	0.110	0.150	0.200
Cleared land with tree stumps, no sprouts	0.030	0.040	0.050
Same as above, but with heavy growth of sprouts	0.050	0.060	0.080
Heavy stand of timber, a few down trees, little undergrowth, flood stage below branches	0.080	0.100	0.120
Same as above, but with flood stage reaching branches	0.100	0.120	0.160
Major Streams (top width at flood stage > 100 ft)			
Regular section with no boulders or brush	0.025	3/4	0.060
Irregular and rough section	0.035	3/4	0.100

Table 4. Manning's n Values for Culverts

Type of Culvert	Roughness or Corrugation	Manning's n
Concrete Pipe	Smooth	0.010-0.011
Concrete Boxes	Smooth	0.012-0.015
Spiral Rib Metal Pipe	Smooth	0.012-0.013
Corrugated Metal Pipe, Pipe-Arch and Box (Annular and Helical corrugations, Manning's n varies with barrel size)	2-2/3 in by 1/2 in Annular	0.022-0.027
	2-2/3 in by 1/2 in Helical	0.011-0.023
	6 in by 1 in Helical	0.022-0.025
	5 in by 1 in	0.025-0.026
	3 in by 1 in	0.027-0.028
	6 in by 2 in Structural Plate	0.033-0.035
	9 in by 2-1/2 in Structural Plate	0.033-0.037
Corrugated Polyethylene	Smooth	0.009-0.015
Corrugated Polyethylene	Corrugated	0.018-0.025
Polyvinyl chloride (PVC)	Smooth	0.009-0.011

*NOTE: The Manning's n values indicated in this table were obtained in the laboratory and are supported by the provided reference. Actual field values for culverts may vary depending on the effect of abrasion, corrosion, deflection, and joint conditions.

Table 5. Runoff Curve Numbers¹

Cover Type and Hydrologic Condition		Avg Percent Imperviousness ²	A	B	C	D
Cultivated Land:	Without Conservation Treatment		72	81	88	91
	With Conservation Treatment		62	71	78	81
Pasture or range land:	Poor Condition		68	79	86	89
	Good Condition		39	61	74	80
Meadow:	Good Condition		30	58	71	78
Wood or forest land:	Thin Stand, Poor Cover		45	66	77	83
	Good Condition		25	55	70	77
Open space (lawns, parks, golf courses, cemeteries, etc) ³ :	Poor Condition (Grass Cover <50%)		68	79	86	89
	Fair Condition (Grass Cover 50% to 75%)		49	69	79	84
	Good Condition (Grass Cover >75%)		39	61	74	80
Impervious areas:	Paved Parking Lots, Roofs, Driveways, etc (excluding right-of-way)		98	98	98	98
	Paved; Curbs and Storm Drains (excluding right-of-way)		98	98	98	98
Streets and roads:	Paved; Open Ditches (including right-of-way)		83	89	92	93
	Gravel (including right-of-way)		76	85	89	91
	Dirt (including right-of-way)		72	82	87	89
Urban Districts:	Commercial and Business	85%	89	92	94	95
	Industrial	72%	81	88	91	93
Residential Districts:	1/8 acre or less (townhouses)	65%	77	85	90	92
	1/4 acre	38%	61	75	83	87
	1/3 acre	30%	57	72	81	86
	1/2 acre	25%	54	70	80	85
	1 acre	20%	51	68	79	84
	2 acres	12%	46	65	77	82
Developing Urban Areas and Newly Graded areas (pervious areas only, no vegetation)			77	86	91	94

Table 5. Runoff Curve Numbers (continued)

¹Average runoff condition, and $I_a = 0.2S$

²The average percent impervious area shown was used to develop the composite CNs. Other assumptions are as follows: impervious areas are directly connected to the drainage system, impervious areas have a CN of 98 and pervious areas are considered equivalent to open space in good hydrologic condition. If the impervious area is not connected, the NRCS TR-55 method has an adjustment to reduce the effect.

³CNs shown are equivalent to those of pasture. Composite CNs may be computed for other combinations of open space cover type.

Table adapted from Table 3.1.5-1 of Volume 2 of the Georgia Stormwater Management Manual (2016 Edition)

Intentionally Left Blank

Appendix E. FHWA Culvert Design Form

PROJECT: _____ STATION: _____ OF _____ SHEET _____ OF _____	CULVERT DESIGN FORM DESIGNER / DATE: _____ / _____ REVIEWER / DATE: _____ / _____	ROADWAY ELEVATION: _____ () 																																																																																					
HYDROLOGICAL DATA <input type="checkbox"/> METHOD: _____ <input type="checkbox"/> DRAINAGE AREA: _____ <input type="checkbox"/> STREAM SLOPE: _____ <input type="checkbox"/> CHANNEL SHAPE: _____ <input type="checkbox"/> ROUTING: _____ <input type="checkbox"/> OTHER: _____		DESIGN FLOWS/TAIWATER FLOW (cfs) _____ TW (ft) _____ R.I. (YEARS) _____																																																																																					
CULVERT DESCRIPTION: MATERIAL - SHAPE - SIZE - ENTRANCE _____		HEADWATER CALCULATIONS <table border="1" style="width:100%; border-collapse: collapse;"> <thead> <tr> <th>Flow Per Barrel Q/N (1)</th> <th>Total Flow Q (cfs)</th> <th>HW/D (2)</th> <th>HW (3)</th> <th>EL_i (4)</th> <th>TW (5)</th> <th>d_c (6)</th> <th>$\frac{d_c + D}{2}$ (6)</th> <th>h_b (6)</th> <th>k_e (7)</th> <th>H (7)</th> <th>EL_o (8)</th> <th>Outlet Velocity</th> <th>Comments</th> </tr> </thead> <tbody> <tr><td> </td><td> </td><td> </td><td> </td><td> </td><td> </td><td> </td><td> </td><td> </td><td> </td><td> </td><td> </td><td> </td><td> </td></tr> <tr><td> </td><td> </td><td> </td><td> </td><td> </td><td> </td><td> </td><td> </td><td> </td><td> </td><td> </td><td> </td><td> </td><td> </td></tr> <tr><td> </td><td> </td><td> </td><td> </td><td> </td><td> </td><td> </td><td> </td><td> </td><td> </td><td> </td><td> </td><td> </td><td> </td></tr> <tr><td> </td><td> </td><td> </td><td> </td><td> </td><td> </td><td> </td><td> </td><td> </td><td> </td><td> </td><td> </td><td> </td><td> </td></tr> <tr><td> </td><td> </td><td> </td><td> </td><td> </td><td> </td><td> </td><td> </td><td> </td><td> </td><td> </td><td> </td><td> </td><td> </td></tr> </tbody> </table>		Flow Per Barrel Q/N (1)	Total Flow Q (cfs)	HW/D (2)	HW (3)	EL _i (4)	TW (5)	d _c (6)	$\frac{d_c + D}{2}$ (6)	h _b (6)	k _e (7)	H (7)	EL _o (8)	Outlet Velocity	Comments																																																																						
Flow Per Barrel Q/N (1)	Total Flow Q (cfs)	HW/D (2)	HW (3)	EL _i (4)	TW (5)	d _c (6)	$\frac{d_c + D}{2}$ (6)	h _b (6)	k _e (7)	H (7)	EL _o (8)	Outlet Velocity	Comments																																																																										
TECHNICAL FOOTNOTES: (1) USE Q/NB FOR BOX CULVERTS (2) HW, / D = HW / D OR HW, / D FROM DESIGN CHARTS (3) T = HW - (EL _i - EL _o) T IS ZERO FOR CULVERTS ON GRADE		(4) EL _i = HW + EL (INVERT OF INLET CONTROL SECTION) (5) TW BASED ON DOWN STREAM CONTROL OR FLOW DEPTH IN CHANNEL (6) h _b = TW or (d _c + D) / 2 (WHICHEVER IS GREATER) (7) H = [1 + k _e + (K _e n ² L) / R ^{1.35}] v ² / 2g WHERE Ku = 19.63 (29 IN ENGLISH UNITS) (8) EL _o = EL _o + H + h _b																																																																																					
SUBSCRIPT DEFINITIONS: a. APPROXIMATE f. CULVERT FACE hb. ALLOWABLE HEADWATER hi. HEADWATER IN INLET CONTROL ho. HEADWATER IN OUTLET CONTROL i. INLET CONTROL SECTION o. OUTLET sd. STREAMBED AT CULVERT FACE tw. TAILWATER		COMMENTS / DISCUSSION: _____ _____ _____ _____ _____ _____																																																																																					
		CULVERT BARREL SELECTED: SIZE: _____ SHAPE: _____ MATERIAL: _____ n _____ ENTRANCE: _____																																																																																					

Intentionally Left Blank

Appendix F. Culvert Design Data Checklist

Documentation Project Checklist

Indicate & Briefly Describe all Appropriate Items

Engineer: _____ Project: _____

City/County: _____ Description: _____

<u>Applicable</u>	<u>Reference Data</u>
	Drainage Area
_____	Field Survey
_____	Photogrammetric Maps
_____	USGS Quad Maps
_____	USGS DEM
	Design Flow
_____	Hydrologic Method
	Headwater Depth
_____	Damage to Adjacent Property
_____	Damage to the culvert and the Roadway
_____	Traffic Interruption
_____	Hazardous to human life
_____	Damage to stream and/or floodplain environment
	Tailwater
_____	Field Surveys
_____	Assumed
_____	Ignored
	Roadway Data
_____	Proposed Cross Section
_____	Proposed Profile
	Culvert Data
_____	Length & Slope
_____	Inverts
_____	Entrance Type
	Stream Data
_____	Slope
_____	Manning's n
_____	Cross Section

Intentionally Left Blank

Appendix G. Sample NOI

See next pages for sample NOI

NOTICE OF INTENT
VERSION October 15, 2017
State of Georgia
Department of Natural Resources
Environmental Protection Division

Permittee NOI Number
Application Submittal Date

**For Coverage Under the 2013 Re-Issuance of the NPDES General Permits
To Discharge Storm Water Associated With Construction Activity**

THESE PERMITS EXPIRE JULY 31, 2018

PRIMARY PERMITTEE

To submit this Notice of Intent electronically please go to

<https://geos.epd.georgia.gov/GA/GEOS/Public/GovEnt/Shared/Pages/Main/Login.aspx>

For instructions on how to do this, please go to

<https://epd.georgia.gov/geos/documents/construction-stormwater-instructions>

Facility Information

Facility Name: _____

Mailing Address 1: _____ Mailing Address 2: _____

County: _____ City: _____ State: _____ Zip Code: _____

Facility/Property Address 1: _____ Address 2: _____

County: _____ City: _____ State: _____ Zip Code: _____

Latitude: _____ Longitude: _____

PRIMARY PERMITTEE:

Road projects are GAR100002

Buildings are GAR100001

COVERAGE DESIRED (Check only one):

- GAR100001- Stand Alone
- GAR100002- Infrastructure
- GAR100003- Common Development

NOTICE OF INTENT (Check only one):

- Initial Notification
- Re-Issuance Notification
- Change of Information

Change of Owner/Operator: Formerly Known As: _____

I.SITE/OWNER/OPERATOR INFORMATION

For GAR100002 projects only- GPS Locations of the Beginning and End of the Infrastructure Project (decimal degrees):

Latitude _____ Longitude _____

Latitude _____ Longitude _____

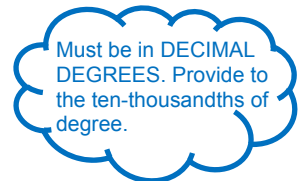

Facility Ownership Type:

- Animal Feeding Operation County Government Private Institutional Development State Government
- Corporation Industrial Municipal or Water District Tribal Government
- City Government Industrial Cooling Water Mixed Ownership (e.g., Public/Private)
- Federal Facility Industrial Rock Quarry Privately Owned Facility

Owner's Name: Georgia Department of Transportation Phone: 404-631-1990
Email Address: ESPCP@dot.ga.gov Address: 600 West Peachtree St.
City: Atlanta State: GA Zip Code: 30308
Duly Authorized Representative(s): _____ Phone: _____
Email Address: _____
Operator's Name: Contractor's Name – Leave Blank Phone: Leave Blank
Email Address: Contractor's Email – Leave Blank Address: Leave Blank
City: Leave Blank State: Leave Blank Zip Code: Leave Blank
Facility/Construction Site Contact: Contractor's WECS – Leave Blank Phone: Leave Blank
Contractor's WECS Email – Leave
Email Address: Blank

II.CONSTRUCTION SITE ACTIVITY INFORMATION AND FEE CALCULATIONS

Start Date: Leave Blank Completion Date: Leave Blank

1. Regulated by a certified Local Issuing Authority (LIA)?: Yes No

Name of Local Issuing Authority: _____

2. Is this an Agricultural Building? (ex. chicken house): Yes No

3. Is this a public water system reservoir?: Yes No

4. Is this project regulated by the Public Service Commission (PSC) or the Federal Energy Regulatory Commission(FERC)"? (ex. Electricity, natural gas, telecom, pipeline):
 Yes No

5. Is this a construction and/or maintenance project undertaken and/or financed in whole or in part by the Department of Transportation, The Georgia Highway Authority, or the State Road and Tollway Authority?
 Yes No

6. Is this a road construction and/or maintenance project (including sidewalks, bike routes, multi-use paths or trails) undertaken by any county or municipality?
 Yes No

TO CALCULATE FEES DUE: If the answer to Question 1 is Yes and the answer to question 2-6 is No, go to Section A. If the answer to Question 1 is No, go to Section B. If the answer to Question 1 is Yes and the answer to any of questions 2-6 is Yes, then go to Section C.

- A. Acres Disturbed (to the nearest tenth [1/10th] acre): _____ X \$40/acre= _____
- B. Acres Disturbed (to the nearest [1/10th] acre): _____ X \$80/acre= _____
- C. Acres Disturbed to the nearest [1/10th] acre) _____ X \$80/acre= _____
- TOTAL FEE DUE:** _____

Disturbed Acreage consistent with
Drainage Map & Sediment Storage

PLEASE MAKE CHECKS PAYABLE TO: Department of Natural Resources - EPD

DO NOT MAIL CASH

Name on Check/Money Order: _____

Check/Money Order Number: _____

(Do Not Include Fees Payable to the LIA)

Check/Money Order Amount: _____

Does the Erosion, Sedimentation and Pollution Control Plan (Plan) provide for disturbing more than 50 acres at any time for each individual permittee (i.e., primary, secondary or tertiary permittees), or more than 50 contiguous acres total at any one time?

YES- _____ Date of EPD Written Authorization

NO

N/A- if construction activities are covered under the General NDPES Permit No. GAR100002 for infrastructure construction projects

Construction Activity Type:

Commercial

Industrial

Municipal/Institutional

Water Quality/Aquatic Habitat Restoration

Linear

Utility

Road projects are Linear
Buildings are Municipal

Agricultural Buildings

Other

N/A

III. RECEIVING WATER INFORMATION

The first water body the project drains to that is named on the USGS map. Multiple water bodies may need to be listed.

A. Name of Initial Receiving Water(s): _____

Trout Stream

Water Supporting Warm Water Fisheries

Mark one

B. Name of MS4 Receiving Waters: Fill in if tying into a city or county stormwater system

Trout Stream

Water Supporting Warm Water Fisheries

Name of MS4 Owner/Operator: Fill in if all outfalls discharge into a municipal sewer

C. Sampling of Receiving Stream(s):

Mark one or both if using receiving water sampling

Mark one for the primary sampling location.

Trout Stream (Δ 10 NTU)

Water Supporting Warm Water Fisheries (Δ 25 NTU)

D. Sampling of Outfall(s):

N/A

Trout Stream

Water Supporting Warm Water Fisheries

Leave if all outfalls connect into an MS4

Mark one or both if using receiving water sampling

A summary chart (if applicable) delineating the following information for each outfall must be attached:

Number of Sampling Outfalls: _____

Construction Site Size (acres): _____

Appendix B NTU Value: _____

Surface Water Drainage Area (square miles): _____

Fill in, if using outfall sampling. All information is found on the Drainage Area Map and/or monitoring table. Leave blank if all outfalls connect into an MS4. Attach 8.5" X 11" of sampling table from ESPCP.

E. Does the facility/construction site discharge storm water into and Impaired Stream Segment, or within one (1) linear mile upstream of and within the same watershed as, any portion of an Impaired Stream Segment identified as "not supporting" its designated use(s), as shown on Georgia's most current "305(b)/303(d) List Documents (Final)" listed for the criteria violated, "Bio F" (Impaired Fish Community) and/or "Bio M" (Impaired Macroinvertebrate Community), within Category 4a, 4b or 5, and the potential cause is either "NP" (nonpoint source) or "UR" (urban runoff)?

No Yes, Name of Impaired Stream Segment(s) List all Bio F/Bio M stream segments (if applicable)

F. Does the facility site discharge storm water into an Impaired Stream Segment where a Total Maximum Daily Load (TMDL) Implementation Plan for "sediment" was finalized at least six (6) months prior to the submittal of the Initial NOI?

No Yes, Name of Impaired Stream Segment(s) List all stream segments that have TMDL plans for sediment (if applicable)

IV. CERTIFICATIONS:

To be initialed by the Commissioner

I certify that to the best of my knowledge and belief, that the Erosion, Sedimentation and Pollution Control Plan (Plan) was prepared by a design professional, as defined by this permit, that has completed the appropriate certification course approved by the Georgia Soil and Water Conservation Commission in accordance with the provisions of O.C.G.A. 12-7-19 and that I will adhere to the Plan and comply with all applicable requirements of this permit.

To be initialed by the Commissioner

I certify under penalty of law that this document and all attachments were prepared under my direction or supervision in accordance with a system designed to assure that certified personnel gather and evaluate the information submitted. Based upon my inquiry of the person or persons who manage the system, or those persons directly responsible for gathering the information, the information submitted is, to the best of my knowledge and belief, true, accurate and complete. I am aware that there are significant penalties for submitting false information, including the possibility of fines and imprisonment for knowing violations.

Owner's Signature: Leave Blank

Date: Leave Blank

AND/OR

Operator's Signature: Leave Blank

Date: Leave Blank

IMPORTANT – Notice of Intent (NOI) is not valid if:

Form is incomplete or fields are missing information.

Signatures by the owner and/or operator are missing in Section V. Certifications.

Signed copies are not received at the appropriate EPD District Office. Mailing addresses listed on Pages 9 – 10.

Check/Money Order not received at the EPD P.O. Box address listed below.

HOW TO SUBMIT THIS NOTIFICATION

1. Complete this form (print or type) and sign. Please retain a copy of the completed and signed form for your records.
2. Mail the signed copy with the applicable attachments to the appropriate EPD District Office (mailing addresses listed on Pages 9 – 10). Do not send checks/money orders to the EPD District Offices.
3. If fees are required, sign a second copy of this completed form. **DO NOT MAIL CASH.** Make check/money order payable to: **Department of Natural Resources – EPD.**
4. Mail the check/money order with the second copy of the completed and signed form to:

EPD – Construction Land Disturbance Fees
P.O. Box 932858
Atlanta, GA 31193-2858

INSTRUCTIONS

NOTICE OF INTENT - PRIMARY PERMITTEE

For Coverage Under the 2013 Re-Issuance of the NPDES General Permits To Discharge Storm Water Associated With Construction Activity

THESE PERMITS EXPIRE JULY 31, 2018

Electronic submittal is now available - **To submit this Notice of Intent electronically please go to:**

<https://geos.epd.georgia.gov/GA/GEOS/Public/GovEnt/Shared/Pages/Main/Login.aspx>

For instructions on how to do this, please go to:

<https://epd.georgia.gov/geos/documents/construction-stormwater-instructions>

Please print or type the Notice of Intent (NOI) form. Any NOI that contains illegible or incomplete information will not be accepted, will be returned and the construction site will not be granted Permit coverage. All information requested on the NOI must be submitted in order for the NOI to be valid. Any information requested on the NOI that is not applicable to the primary permittee or to the construction site must be marked "N/A." Please do not leave any sections blank in the NOI.

Who must file a Notice of Intent Form - The Owner and/or Operator of a facility/construction site that has a discharge of storm water where construction activities occur must apply for a National Pollutant Discharge Elimination System (NPDES) Permit. The Georgia Environmental Protection Division (EPD) re-issued the General NPDES Permits for Storm Water Discharges Associated with Construction Activity on September 24, 2013. The Permits are available for review at the EPD District Offices and on the EPD website, epd.georgia.gov. It is highly recommended that the permittees read and understand the terms and conditions of the Permits prior to submitting a NOI. Please contact the appropriate EPD District Office as listed on the following pages for assistance in completing the NOI.

Where to file a Notice of Intent Form - The NOI and the attachments, as applicable, must be submitted to the appropriate EPD District Office as listed on the following pages. Please submit only the first five pages of this document with the applicable attachments.

Section I - Site/Owner/Operator Information

The construction site name and location information (i.e., GPS location of construction exit, street address, city, county) must be sufficient to accurately locate the construction site. If the construction site does not have a street address, please provide sufficient information to accurately locate the construction site. If additional space is needed, attach the location information to the NOI.

A duly authorized representative may be either a named individual or any individual occupying a named position that the primary permittee has authorized to sign certification statements, inspection reports, sampling reports or other reports requested by EPD.

The facility/construction site contact is the person who the primary permittee has assigned the responsibility for the daily on-site operational control.

Please do not leave any blanks in this section. Any information requested on the NOI that is not applicable to the primary permittee or to the construction site must be mark "N/A."

Section II – Construction Site Activity Information and Fee Calculations

The Primary Permittee is solely responsible for the payment of fees for all **planned** land disturbing activities, including all land disturbing activities within a common development planned by the Secondary Permittees and/or Tertiary Permittees. Estimated disturbed acreage is the total number of acres, to nearest tenth (1/10th) acre. Only the Primary Permittee is responsible for paying the NPDES General Permit fees.

If the Primary Permittee has already paid the applicable fees, the Primary Permittee does not pay any additional NPDES General Permit fees, unless the scope of work covered under the NPDES General Permit so paid for is increased.

For land disturbing activities submitting an *Initial* Notice of Intent *in an area with no certified Local Issuing Authority* **OR** *for land disturbing activities not regulated by a certified Local Issuing Authority*, the Primary Permittee shall pay a fee of **\$80 per acres disturbed** to EPD (to the nearest tenth (1/10th) acre).

Land disturbing activities not regulated by a certified Local Issuing Authority include, but are not limited to:

- Construction of public water system reservoirs.
- Land disturbing activities conducted by any electric membership corporation or municipal electrical system or any public under the regulatory jurisdiction of the Public Service Commission, any utility under the regulatory jurisdiction of the Federal Energy Regulatory Commission, any cable television system as defined in O.C.G.A. §36-18-1, or any agency or instrumentality of the United States engaged in the generation, transmission or distribution power, except when the project is located within a common development as described in the NPDES General Permits.
- Construction of agricultural buildings (e.g., barns, poultry houses).
- Construction or maintenance projects undertaken or financed by the Department of Transportation, the Georgia Highway Authority, the State Road and Tollway Authority, or any county or municipality, except when the Department of Transportation, the Georgia Highway Authority or the State Road and Tollway Authority is a Secondary Permittee within a common development.
- Projects carried out under the technical supervision of the Natural Resources Conservation Service of the United States Department of Agricultural.

For land disturbing activities submitting an *Initial* Notice of Intent *regulated by a certified Local Issuing Authority*, the Primary Permittee shall pay a fee of **\$40 per acres disturbed** to EPD **AND** a fee of **\$40 per acres disturbed** to the Local Issuing Authority (to the nearest tenth (1/10th) acre). Payments to the Local Issuing Authority should be made in the manner specified by the Local Issuing Authority and should not be submitted to EPD. The NPDES General Permit fees are **in addition** to any local land disturbing activity fees that are required by the Local Issuing Authority.

Make checks/money orders payable to: **Department of Natural Resources - EPD**

Please do not leave any blanks in this section. Any information requested on the NOI that is not applicable to the primary permittee or to the construction site must be mark "N/A."

Section III - Receiving Water Information

“Trout Streams” are waters of the State classified as either primary trout waters or secondary trout waters, as designated in the Rules and Regulations for Water Quality Control, Chapter 391-3-6 at epd.georgia.gov. “Waters Supporting Warm Water Fisheries” are all waters of the State that sustain, or have the potential to sustain, aquatic life but exclude “Trout Streams.”

If the facility/construction site discharges storm water directly or indirectly to the receiving water(s), and not through a municipal separate storm sewer system (MS4), enter the name of the receiving water(s) and indicate whether the water(s) is a trout stream or a warm water fisheries stream. Attach a written description and location map identifying the receiving water(s).

If the facility/construction site discharges storm water to a municipal separate storm sewer system (MS4), enter the name of the owner/operator of the MS4 (e.g., city name or county name) and the name of the receiving water(s) at the point of discharge from the MS4. A MS4 is defined as a conveyance or system of conveyances (including roads with drainage systems, municipal streets, catch basins, curbs, gutters, ditches, man-made channels or storm drains) that is owned and/or operated by a city or county which is designed or used for collecting or conveying storm water. It may be necessary to contact the city or county that owns and/or operates the MS4 to determine the name of the receiving water(s). Indicate whether the receiving water(s) is a trout stream or a warm water fisheries stream. Attach a written description and location map identifying the receiving water(s).

Any permittee who intends to obtain coverage under the Permits for storm water discharges associated with construction activity into an Impaired Stream Segment, or within one (1) linear mile upstream of and within the same watershed as, any portion of an Impaired Stream Segment identified as “not supporting” its designated use(s), as shown on Georgia’s most current “305(b)/303(d) List Documents (Final)” at the time of NOI submittal, must satisfy the requirements of Part III.C. of the Permits if the Impaired Stream Segment has been listed for criteria violated, “Bio F” (Impaired Fish Community) and/or “Bio M” (Impaired Macroinvertebrate Community), within Category 4a, 4b or 5, and the potential cause is either “NP” (nonpoint source) or “UR” (urban runoff). Those discharges that are located within one (1) linear mile of an Impaired Stream Segment, but are not located within the watershed of any portion of that stream segment, are excluded from this requirement. Georgia’s 2012 and subsequent 305(b)/303(d) List Documents (Final)” can be viewed on the EPD website, <http://epd.georgia.gov/georgia-305b303d-list-documents>. Attach a written description and location map identifying the Impaired Stream Segment(s).

If a Total Maximum Daily Load (TMDL) Implementation Plan for sediment has been finalized at least six (6) months prior to the permittee’s submittal of the Initial NOI, the Erosion, Sedimentation and Pollution Control Plan (Plan) must address any site-specific conditions or requirements included in the TMDL Implementation Plan that are applicable to the permittee’s discharge(s) to the Impaired Stream Segment within the timeframe specified in the TMDL Implementation Plan. If the TMDL Implementation Plan establishes a specific numeric wasteload allocation that applies to the permittee’s discharge(s) to the Impaired Stream Segment, then the permittee must incorporate that allocation into the Erosion, Sedimentation and Pollution Control Plan and implement all necessary measures to meet that allocation. A list of TMDL Implementation Plans can be viewed on the EPD website, <http://epd.georgia.gov/total-maximum-daily-loadings>.

Please do not leave any blanks in this section. Any information requested on the NOI that is not applicable to the primary permittee or to the construction site must be mark “N/A.”

Section V – Certifications

The owner and/or operator must sign the Notice of Intent and initial the certification statements on the lines provided. Federal and State statutes provide specific requirements as to who is authorized to sign the Notice of Intent forms. A Notice of Intent form signed by an unauthorized person will not be valid. Please be aware that Federal and State statutes provide for severe penalties for submitting false information on this Notice of Intent form. Federal and State regulations require that the Notice of Intent form be signed as follows:

- For a corporation, by a responsible corporate officer;
- For a partnership or sole proprietorship, by a general partner or the proprietor; and
- For a municipality, State, Federal or other public facility, by either a principal executive officer or ranking elected official.

GEORGIA EPD DISTRICT OFFICES

All required correspondence, including but not limited to Notices of Intent, Notices of Termination, Erosion, Sedimentation and Pollution Control Plans, sampling reports and any other reports shall be sent to the following EPD District Offices:

A. For facilities/construction sites located in the following counties: Bibb, Bleckley, Chattahoochee, Crawford, Dooly, Harris, Houston, Jones, Lamar, Macon, Marion, Meriwether, Monroe, Muscogee, Peach, Pike, Pulaski, Schley, Talbot, Taylor, Troup, Twiggs, Upson

Information shall be submitted to: West Central District Office
Georgia Environmental Protection Division
2640 Shurling Drive
Macon, GA 31211-3576
(478) 751-6612

B. For facilities/construction sites located in the following counties: Burke, Columbia, Emanuel, Glascock, Jefferson, Jenkins, Johnson, Laurens, McDuffie, Montgomery, Richmond, Screven, Treutlen, Warren, Washington, Wheeler, Wilkinson

Information shall be submitted to: East Central District Office
Georgia Environmental Protection Division
3525 Walton Way Extension
Augusta, GA 30909-1821
(706) 667-4343

C. For facilities/construction sites located in the following counties: Baldwin, Banks, Barrow, Butts, Clarke, Elbert, Franklin, Greene, Hall, Hancock, Hart, Jackson, Jasper, Lincoln, Madison, Morgan, Newton, Oconee, Oglethorpe, Putnam, Stephens, Taliaferro, Walton, Wilkes

Information shall be submitted to: Northeast District Office
Georgia Environmental Protection Division
745 Gaines School Road
Athens, GA 30605-3129
(706) 369-6376

D. For facilities/construction sites located in the following counties: Carroll, Clayton, Coweta, DeKalb, Douglas, Fayette, Fulton, Gwinnett, Heard, Henry, Rockdale, Spalding

Information shall be submitted to: Mountain District - Atlanta Satellite
Georgia Environmental Protection Division
4244 International Parkway, Suite 114
Atlanta, GA 30354-3906
(404) 362-2671

E. For facilities/construction sites located in the following counties: Bartow, Catoosa, Chattooga, Cherokee, Cobb, Dade, Dawson, Fannin, Floyd, Forsyth, Gilmer, Gordon, Habersham, Haralson, Lumpkin, Murray, Paulding, Pickens, Polk, Rabun, Towns, Union, Walker, White, Whitfield

Information shall be submitted to: Mountain District - Cartersville Office
Georgia Environmental Protection Division
P.O. Box 3250
Cartersville, GA 30120-1705
(770) 387-4900

F. For facilities/construction sites located in the following counties: Appling, Atkinson, Bacon, Brantley, Bryan, Bulloch, Camden, Candler, Charlton, Chatham, Clinch, Coffee, Effingham, Evans, Glynn, Jeff Davis, Liberty, Long, McIntosh, Pierce, Tattnall, Toombs, Ware, Wayne

Information shall be submitted to: Coastal District - Brunswick Office
Georgia Environmental Protection Division
400 Commerce Center Drive
Brunswick, GA 31523-8251
(912) 264-7284

G. For facilities/construction sites located in the following counties: Baker, Ben Hill, Berrien, Brooks, Calhoun, Clay, Colquitt, Cook, Crisp, Decatur, Dodge, Dougherty, Early, Echols, Grady, Irwin, Lanier, Lee, Lowndes, Miller, Mitchell, Quitman, Randolph, Seminole, Stewart, Sumter, Telfair, Terrell, Thomas, Tift, Turner, Webster, Wilcox, Worth

Information shall be submitted to: Southwest District Office
Georgia Environmental Protection Division
2024 Newton Road
Albany, GA 31701-3576
(229) 430-4144

Intentionally Left Blank

Appendix H. MS4 Areas

Phase I MS4s

Acworth	Doraville	Marietta
Alpharetta	Duluth	Morrow
Atlanta	East Point	Palmetto
Augusta-Richmond County	Fairburn	Pine Lake
Austell	Forest Park	Pooler
Avondale Estates	Forsyth County	Port Wentworth
Berkeley Lake	Fulton County	Powder Springs
Bloomington	Garden City	Riverdale
Buford	Grayson	Roswell
Chamblee	Gwinnett County	Savannah
Chatham County	Hapeville	Smyrna
Clarkston	Jonesboro	Snellville
Clayton County	Kennesaw	Stone Mountain
Cobb County	Lake City	Sugar Hill
College Park	Lawrenceville	Suwanee
Columbus	Lilburn	Thunderbolt
Dacula	Lithonia	Tybee Island
Decatur	Lovejoy	Union City
DeKalb County	Macon-Bibb County	

Phase II MS4s

Counties:

Athens-Clarke	Fayette (2017 permit)	Madison (2017 permit)
Barrow	Floyd	Murray (2017 permit)
Bartow	Glynn	Newton
Carroll (2017 permit)	Hall	Oconee
Catoosa	Henry	Paulding
Cherokee	Houston	Peach
Columbia	Jackson (2017 permit)	Rockdale
Coweta	Jones	Spalding
Dawson (2017 permit)	Lee	Walker
Dougherty	Liberty	Walton
Douglas	Long	Whitfield
Effingham (2017 permit)	Lowndes	

Cities:

Albany (Dougherty Co.)	Hoschton (Jackson Co.) (2017 permit)
Allenhurst (Liberty Co.)	Johns Creek (Fulton Co.)
Auburn (Barrow Co.)	Leesburg (Lee Co.)
Bogart (Oconee Co.)	Locust Grove (Henry Co.) (2017 permit)
Braselton (Jackson Co.) (2017 permit)	Loganville (Walton Co.)
Brunswick (Glynn Co.)	Lookout Mountain (Walker Co.)
Byron (Peach Co.)	McDonough (Henry Co.)
Canton (Cherokee Co.)	Milton (Fulton Co.)
Cartersville (Bartow Co.) (2017 permit)	Mountain Park (Fulton Co.)
Centerville (Houston Co.)	Newnan (Coweta Co.)
Chatsworth (Murray Co.) (2017 permit)	Oakwood (Hall Co.)
Chickamauga (Walker Co.)	Oxford (Newton Co.)
Conyers (Rockdale Co.)	Peachtree City (Fayette Co.)
Cordele (Crisp Co.)	Perry (Houston Co.) (2017 permit)
Covington (Newton Co.)	Porterdale (Newton Co.)
Cumming (Forsyth Co.)	Remerton (Lowndes Co.)
Dallas (Paulding Co.)	Richmond Hill (Bryan Co.) (2017 permit)
Dalton (Whitfield Co.)	Ringgold (Catoosa Co.)
Douglasville (Douglas Co.)	Rome (Floyd Co.)
Dunwoody (DeKalb Co.)	Rossville (Walker Co.)
Emerson (Bartow Co.)	Sandy Springs (Fulton Co.)
Eton (Murray Co.) (2017 permit)	Senoia (Coweta Co.) (2017 permit)
Euharlee (Bartow Co.) (2017 permit)	Stockbridge (Henry Co.)
Fayetteville (Fayette Co.)	Temple (Carroll Co.) (2017 permit)
Flemington (Liberty Co.)	Tunnel Hill (Whitfield Co.)
Flowery Branch (Hall Co.)	Tyrone (Fayette Co.)
Fort Oglethorpe (Catoosa Co.)	Valdosta (Lowndes Co.)
Gainesville (Hall Co.)	Varnell (Whitfield Co.)
Griffin (Spalding Co.)	Villa Rica (Carroll Co.) (2017 permit)
Grovetown (Columbia Co.)	Walnut Grove (Walton Co.) (2017 permit)
Hahira (Lowndes Co.) (2017 permit)	Walthourville (Liberty Co.)
Hampton (Henry Co.)	Warner Robins (Houston Co.)
Hephzibah (Richmond Co.)	Watkinsville (Oconee Co.)
Hinesville (Liberty Co.)	Winterville (Clarke Co.)
Hiram (Paulding Co.)	Woodstock (Cherokee Co.)
Holly Springs (Cherokee Co.)	

Appendix I. Additional Bridge Information

Section 1 - Contents List for Riverine Hydraulic and Hydrologic Study

1. **Cover Sheet.** The following information shall be shown:
 - a. Project number, PI number, Route and stream name;
 - b. Statement whether coordination with FEMA and/or the Community is required; and
 - c. Signature and date. **Note: For Consultant projects, the Hydraulic and Hydrologic Study shall be stamped and signed by a registered Professional Engineer**
2. **Hydraulic and Hydrologic Report.** Include the description of the project, the alternates considered, the methods of analysis along with determination of boundary conditions, and the conclusions for the site. **The reason(s) for choosing the proposed drainage structure should be specified. Note: The proposed drainage structure(s) should be sized as the minimum length bridge, or smallest culvert, or most cost effective combination of drainage structures that have acceptable backwater and velocity values, fits the stream channel geometry, meets FEMA requirements if applicable, while adhering to the procedures, guidelines, and design criteria of this manual.**
3. **Site Inspection.** A site inspection shall be performed with the results included in the study. This site inspection should include detailed descriptions of the existing stream channel, upstream and downstream floodplains, existing bridges and/or culverts, development/houses near the site, and any scour, erosion or debris problems, etc.
4. **Scour calculations for bridges.** Bridge scour calculations should include:
 - a. Scour Table: Show the general contraction, local (pier) and total scour for the 100- and 500-year (or overtopping) storms at each intermediate bent;
 - b. Show the general scour calculations for the stream channel and overbanks; and
 - c. Show the local (pier) scour calculations for each intermediate bent.
5. **Scour calculations for bottomless culverts.** Bottomless culvert scour calculations should include:
 - a. Scour Table: Show the general contraction, local (pier) and total scour for the 100- and 500-year (or overtopping) storms at each intermediate wall;
 - b. Show the general scour calculations for the stream channel and overbanks;
 - c. Show the local (pier) scour calculations for each intermediate wall; and
 - d. Show the abutment scour calculations for each abutment.
6. **OES Documentation.** If a bridge is required to be constructed at a site due to environmental considerations, written documentation from the Office of Environmental Services is required to be placed in the hydraulic and hydrologic study. This documentation should state the reasons that a box culvert cannot be constructed at the project site. In addition, any limitations placed on the location of the endrolls and/or intermediate bents for the proposed bridge should be included in this documentation.

7. **Hydraulic Table.** Tables showing the design year and 100-year storm hydraulic values for the natural (unconstricted), existing, and proposed conditions along with any applicable structure alternates. Included are the flood stages at the structure (bridge or culvert) and the unconstricted and constricted flood stages at the upstream approach section. Areas of opening under flood stage, discharge through the structure and over the roadway, channel and mean velocities through the structure, and backwater values. The 2-year flood stage elevation, along with the design year and 100-year storm natural (unconstricted) channel velocities should be shown on this sheet. If the site is affected by abnormal flood stages, separate tables should be shown for the design year and 100-year storm stream floods and abnormal floods. **Note: This table is separate from the hydraulic computer model generated tables. This table contains all of the above-specified hydraulic values that can easily be compared for each storm frequency and condition (I.E., existing, proposed, alternates). See the hydraulic table example contained in this appendix.**
8. **Drainage Calculations.** The drainage area, storm discharge calculations, and hydraulic slope determination shall be shown.
9. **Copies of Gage Data used** (or other supporting data).
10. **Sub-Area Property Calculations.** Using the computer model, show channel and overbank discharges, velocities and areas for the design storm, 100-year storm, and 500-year (or overtopping) storm.
11. **Guide Bank (Spur Dike) Calculations** (bridge only).
12. **Riprap Calculations.**
13. **Hydraulic Engineering Field Report** (see the GDOT Automated Survey Manual).
14. **Cost Comparison.** Cost estimates of the alternate drainage structures shall be included in the study.
15. **Risk Assessment Sheet.**
16. **Bridge Clearance Determination.** Show the proposed bottom of beam clearance over the design year and 100-year flood stage elevations. These floodstage elevations should be taken from the downstream face of the constricted section of the proposed bridge run in the HEC-RAS model, or from the full valley, unconstricted section of the WSPRO model. If abnormal flood stages are present, clearances should also be shown over the respective abnormal flood stage elevations. **See the example hydraulic study in this chapter for an example of this clearance determination sheet.**
17. **Bridge culverts will be subjected to allowable headwater requirements as outline in Chapter 8, Section 8.2.3.**

18. **Roadway Plan Sheets.** Copies of the plan and profile sheets, along with the cover and typical section sheets shall be included. Note: If the proposed drainage structure is a box culvert, a sketch of the culvert placement should be shown on the applicable plan and profile sheet. These roadway sheets should be letter size or half-size copies.
19. **Preliminary Bridge Layout.** A letter size or half-size copy shall be included. **Note: For Consultant projects, the preliminary bridge layout shall be stamped and signed by a registered Professional Engineer.**
20. **County Location Map.** With the project location marked.
21. **USGS Quadrangle Map.** With the project location marked.
22. **Charts, tables and graphs.** Many of the hydraulic computer models have capabilities to show and/or clarify results using these methods. For example, the HEC-RAS computer model results require that the sections be located and identified along a plan view of the stream reach.
23. **Computer Data.**

Input and Output of the hydraulic computer model for the following:

- a. Natural (unconstricted), existing and proposed conditions;

Note: Natural conditions for bridge replacements, widenings and parallelings refers to natural unconstricted conditions at the project site. This computer run removes the existing roadway and structure (bridge or culvert) at the project site. Other structures and constrictions upstream and downstream of the project site remain in the model. The WSPRO model provides this unconstricted natural run automatically.

- b. Applicable alternates; and
- c. Detour structure (if applicable).

Notes: If the WSPRO model is used, include the following input and output from the computer run in the study at a minimum:

- a. the input data;
- b. the final iteration showing the water surface profiles through the stream reach for all required floods; and
- c. the computation of the sub-area properties used in the various hydraulic calculations.

If the HEC-RAS model is used, include the following input and output from the computer run in the study at a minimum:

- a. the report showing all input data;
- b. the schematic plan view of the stream reach showing the location of the cross sections;

- c. the standard profile output tables, numbers 1 and 2;
- d. the six cross section profile table including the bridge or culvert;
- e. the bridge or culvert output tables;
- f. the cross section output tables for the bridge or culvert; and
- g. the scour calculations and results for the proposed bridge or bridge culvert.

The above output tables should include the natural (w/o structure or roadway at the project site) conditions, as well as the existing and proposed bridge conditions for the various required storm discharges as applicable.

At GDOT's discretion, Consultants may be required to include a computer disk with the above runs for GDOT's use.

23. Flood Insurance Study Information.

If the site is located within a FEMA regulatory floodway, the following information is required to be placed within the study:

- a. An explanation of any required modification and/or corrections to the floodway model;
- b. The floodway map with the site marked and any modification delineated;
- c. Floodway data tables for the existing (published), base and proposed conditions;
- d. Flood profile and floodway run input; and
- e. Consultant projects shall also include the flood profile runs for the 10-, 50-, 100- and 500-year storms. The 100-year floodway run is also required.

Note: Consultant's shall include three computer disks with the above runs for GDOT's use and distribution.

Section 2 - Contents List for Tidal Hydraulic and Hydrologic Study

1. **Cover Sheet.** The following information shall be shown:
 - a. Project number, PI number, Route and stream name;
 - b. Statement whether coordination with FEMA and/or the Community is required; and
 - c. Signature and date. **Note: For Consultant projects, the Hydraulic Study shall be stamped and signed by a registered Professional Engineer.**
2. **Hydraulic and Hydrologic Report.** Include the description of the project, the alternates considered, the methods of analysis along with the determination of the boundary conditions, and the conclusions and results for the project.

The reason(s) for choosing the proposed drainage structure should be specified. Note: The proposed drainage structure(s) should be sized as the minimum length bridge, or smallest culvert, or most cost effective combination of drainage structures that have acceptable backwater and velocity values, fits the stream channel geometry, meets FEMA requirements if applicable, while adhering to the procedures, guidelines, and design criteria of this manual.

3. **Site Inspection.** A site inspection shall be performed with the results included in the study. This site inspection should include detailed descriptions of the existing stream channel, upstream and downstream floodplains, existing bridges and/or culverts, development/houses near the site, and any scour, erosion or debris problems, etc.
4. **Scour Report and Calculations.** The scour analysis shall be done for the 100 and 500-year or overtopping upland riverine floods along with the appropriate tidal influences, as well as the 100 and 500-year or overtopping storm tidal surges combined with the appropriate upland riverine flows. The scour tables shall show the worst case scour for the 100 and 500-year (or overtopping) storms.
 - a. Scour Table: Show the general contraction, local (pier) and total scour for the 100- and 500-year (or overtopping) storms at each intermediate bent
 - b. Show the general scour calculations for the stream channel and overbanks
 - c. Show the local (pier) scour calculations for each intermediate bent
5. **OES Documentation.** If a bridge is required to be constructed at a site due to environmental considerations, written documentation from the Office of Environmental Services is required to be placed in the hydraulic study. This documentation should state the reasons that a box culvert cannot be constructed at the project site. In addition, any limitations placed on the location of the endrolls and/or intermediate bents for the proposed bridge should be included in this documentation.
6. **Hydraulic Table.** Tables showing the hydraulic values for the existing and proposed conditions along with any applicable alternates. Included are the flood stages at the bridge and the unconstricted and constricted flood stages at the upstream and downstream sections, areas of opening under flood stage, discharge through the bridge and over the roadway, channel and mean velocities through the bridge, and backwater values. The design year and 100-year storm natural (unconstricted) channel velocities should be shown

on this sheet. There should be tables for the various combinations of upland (riverine) flow with tidal influence, along with the various storm surges with the appropriate upland (riverine) flow.

7. **Drainage Calculations.** The riverine drainage area and the upland storm discharge calculations shall be shown. Average upland (riverine) flows shall be shown as appropriate. The high and low, mean and spring tide elevations shall be shown at the project site. These elevations shall be given to the project datum.
8. **Copies of Gage Data** used (or other supporting data). Copies of the publications, information and methods used to determine the normal and storm surge tidal conditions at the project site shall be provided. Tide gage data shall be included in the study. The various storm hydrographs shall be shown. The [National Geodetic Survey](#) provides information on [tidal benchmarks](#) and conversions between tidal datums (e.g. mean low water) and fixed datums (NGVD-29 and NAVD-88).
9. **Sub-Area Property Calculations.** Using the computer model, show channel and overbank discharges, velocities and areas for the design storm, 100-year storm, and 500-year (or overtopping) storm.
10. **Guide Bank (Spur Dike) Calculations.**
11. **Riprap Calculations.**
12. **Hydraulic Engineering Field Report (see the GDOT Automated Survey Manual).**
13. **Cost Comparison.** Cost estimates of the alternate drainage structures shall be included in the study.
14. **Risk Assessment Sheet.**
15. **Clearance Determination.** Show the proposed bottom of beam clearance over the design year and 100-year flood stage elevations.
16. **Roadway Plan Sheets.** Copies of the plan and profile sheets, along with the cover and typical section sheets shall be included. Note: If the proposed drainage structure is a box culvert, a sketch of the culvert placement should be shown on the applicable plan and profile sheet. These roadway sheets should be letter size or half-size copies.
17. **Preliminary Bridge Layout.** A letter size or half-size copy shall be included. **Note: For Consultant projects, the preliminary bridge layout shall be stamped and signed by a registered Professional Engineer.**
18. **County Location Map.** With the project location marked.
19. **USGS Quadrangle Map.** With the project location marked. Copies of the contour and hydrographic maps showing the extent of the study grid shall be included. Cross sections used in the computer model shall be shown and labeled on these maps.
20. **Charts, tables and graphs.** Diagrams, sketches, tables and plots shall be provided to clearly show the results of the study. Directional velocity vectors showing the direction and value of the storm velocities shall be given in relation to the proposed bridge piers, as applicable, at each site.

21. Computer Data.

Input and Output of the hydraulic computer model for the following:

- a. Existing and proposed conditions
- b. Applicable alternates
- c. Detour structure (if applicable)

Section 3 - Example Hydraulic and Hydrologic Study

Note: The following pages contain a sample written hydraulic and hydrologic study.

Additional samples of hydraulic and hydrologic studies and preliminary bridge layouts can be obtained from GDOT's Bridge Hydraulics Section.

For Consultant projects, a registered professional engineer is required to stamp and sign the cover sheet of the hydraulic and hydrological study.

Intentionally Left Blank

BR-0001-00(369) CLAY CO.

PI NO. 0001369

COUNTY ROAD 76 OVER DRAG NASTY CREEK

HYDRAULIC AND HYDROLOGIC STUDY

EXAMINED AND APPROVED:

____SIGNATURE_____

DATE

**(REQUIRED TO BE STAMPED AND SIGNED
BY A REGISTERED PROFESSIONAL
ENGINEER FOR CONSULTANT PROJECTS)**

FEMA and Community Coordination Required

Community Coordination Only Required

NO FEMA or Community Coordination Required

BR-0001-00(369) CLAY CO.

COUNTY ROAD 76 OVER DRAG NASTY CREEK

HYDRAULIC AND HYDROLOGICAL REPORT

The existing 24 ft wide by 108 ft long bridge at the crossing of County Road 76 over Drag Nasty Creek is proposed to be replaced by a 28 ft wide by 180 ft long PSC beam bridge. The proposed replacement is to be located along the existing alignment. The bents of the proposed bridge are to be built at 60 degrees to the roadway centerline to approximate the flood flow at this site. The bents of the existing bridge are built at 90 degrees to the roadway centerline. The existing bridge is not listed on the Office of Environmental Services' inventory of Historic Bridges of Georgia.

The drainage area of 12.89 sq. miles for the project site was obtained from the USGS quadrangle maps for the area. The 2-, 10-, 100-, and 500-year discharges were determined by using the Region 2 "Flood Frequency Relations" shown in the USGS publication, "Techniques for Estimating Magnitude and Frequency of Floods in Rural Basins of Georgia". The hydraulic slope for this site was obtained from the USGS quadrangle maps for the area.

The proposed bridge width of 28 ft was obtained from M.O.G. no. 4265-9, for local roads not having state route numbers with design year traffic from 0 to 399 VPD. The 10-year storm is the design storm for this county road as per the Georgia Drainage Design Manual for non-state routes with design year traffic from 100 to 399 VPD. The design year traffic at this site is 300 VPD.

The proposed site is located in unincorporated Clay County, Georgia, which participates in the National Flood Insurance Program administered by the Federal Emergency Management Agency (FEMA). A detailed Flood Insurance Study with a regulatory floodway has not been done for this reach of Drag Nasty Creek, so coordination with FEMA or Clay County will not be required.

The proposed bridge is located over a tributary to Lake Walter F. George. The 10-, 100-, and 500. year flood pool elevations were previously obtained from the Mobile Corps of Engineers in August 1998. To determine the extent that the lake flood pool elevations affect the project site, these flood pool elevations were compared with the floodstage elevations at the crossing for the corresponding creek floods. This comparison indicates that only the 500-year lake pool elevation is higher than the corresponding creek flood. The normal pool elevation of 190.0 ft is about two ft deep under the County Road 76 bridge.

The floodstage elevations, areas of opening, velocities, and backwaters for the existing and proposed structures were determined by using the Corps of Engineers "HEC-RAS" computer model. The results from the computer models show that although the site is affected by flood pools from Lake Walter F. George, the controlling floodstages are due to the creek storms, except for the 500-year storm as noted above.

The existing 108 ft long bridge has 10- and 100-year storm channel velocities of 7.95 fps and 10.51 fps, respectively. The existing bridge creates 1.63 ft and 2.71 ft of backwater during the 10- and 100-year storms. The 10- and 100-year natural channel velocities are 4.95 fps and 5.67 fps, respectively. The existing bridge superstructure clears the 10- and 100-year floods with no flow over the roadway taking place.

The proposed 180 ft long bridge was chosen as the replacement structure for this site as the minimum length bridge that limits the 100-year backwater to less than one foot while providing acceptable storm flow velocities. The placement of the end bents of the proposed bridge was set by the geometry of the approaching stream channel. The north end bent was shifted 20 feet ahead of the existing end bent and skewed 60 degrees to align with the approaching stream channel and to avoid direct overbank flow from the channel. The south end bent was moved back approximately 50 feet from the existing end bent due to the severe bend in the stream channel at this end of the bridge. The approaching flow angle of the stream channel directly impacts the existing south endroll and the channel has the potential of migration in this direction. This endroll was washed out in the mid-1990's and has just recently been rebuilt. New rock riprap was placed to protect this rebuilt abutment.

The use of 60 ft long spans enables the proposed bents to be skewed to match the flood flow while also clearing the creek channel which bends to cross under County Road 76 at 90 degrees. The southernmost intermediate bent was placed about 10 to 15 feet beyond the existing limits of the stream channel. Bent number three was placed on the overbank, inside of the channel bend. This should alleviate the past problem of drift accumulating on the intermediate bents. Since the intermediate bents are relatively short at this site, and the next upstream bridge at State Route 39 has PSC pile intermediate bents, PSC piles should be a viable alternative for the foundations at the County Road 76 crossing. The proposed bridge superstructure clears the 50- and 100-year floods with no flow over the roadway taking place.

The proposed 180 ft long bridge has 10- and 100-year storm channel velocities of 5.46 fps and 7.86 fps, respectively. The proposed structure creates 0.68 ft and 0.96 ft of backwater, respectively, for the 10- and 100-year storms.

The maximum calculated general contraction scour depth under the proposed 180 ft long bridge for the 100-year storm is 7.4 ft, occurring in the stream channel area. (See the Predicted Scour Report enclosed in this study).

Guide bank (spur dike) and riprap calculations were performed for this site as prescribed in the FHWA publication, HEC no. 23, "Bridge Scour and Stream Instability Countermeasures". These calculations indicate that a 95 ft long guide bank is required at the south end of the bridge. Guide banks are not required to be built where the calculated length is less than 150 feet as per the Georgia Drainage Design Manual, so no guide banks will be built at this site. Calculations show that Type 1 riprap is sufficient to protect the endrolls of the proposed bridge. Riprap aprons, 15 ft in width, are to be placed to protect the proposed endroll toes.

Although this site has a relatively small drainage area of 12.89 sq. miles, a box culvert alternate was not considered due to the severe bend in the channel at this site. Additional reasons for not considering a culvert at this site are the potential silting problems associated with the location in the backwater of Walter F. George Reservoir, along with reported debris problems at this site.

A risk assessment was made for this site and no risk was determined due to the lack of development in the immediate upstream and downstream floodplains, along with significant reductions in the storm velocities and backwater values from the existing conditions. County Road 76 will be closed during the construction of the new structure.

The required maps, calculations, computer runs, roadway sheets, and preliminary bridge layout are included in the following pages.

Date:

Prepared by:

BR-0001-00(369) CLAY COUNTY
COUNTY ROAD 76 OVER DRAG NASTY CREEK
HYDRAULIC SITE INSPECTION

A hydraulic site inspection was made at the existing bridge crossing on County Road 76 over Drag Nasty Creek on July 10, 2003. The upstream and downstream floodplains are heavily wooded with dense vegetation and sandy soil. The creek is approximately 45 to 55 feet in width and is fairly shallow, slowly flowing, and clear of debris. The creek banks are low and bordered by trees. The creek channel approaches the site at a severe angle, almost parallel to the roadway, and then bends to cross County Road 76 at an approximate angle of 90 degrees. The stream channel flows directly into the southern endroll of the existing bridge at this bend. This endroll was rebuilt after being washed out by a large flood in the mid-1990's. A large area of sand deposits was observed on the north inside bend of the stream channel at the bridge. Small tributaries are located on the northwest and southeast sides of the roadway.

The existing structure is a steel beam bridge with a concrete deck, curb, and guardrail. This bridge consists of four 27 ft long spans on concrete encased steel 'H' pile intermediate bents built at 90 degrees to the roadway centerline. Both endrolls are protected with rock riprap. The existing roadway is a paved county road and ranges from about 10 to 12 feet above the natural groundline near the bridge site. The upstream bridge at State Route 39 over Drag Nasty Creek consists of three 50 ft long spans with PSC pile intermediate bents.

This bridge is located in the backwater of Walter F. George Reservoir, with the normal pool of the lake only about two ft deep at the project site. No development was observed in the immediate upstream or downstream floodplains. Other than the previous problems at the south endroll, no major scour problems were observed at this site.

Date:

Prepared By:

BR-0001-00(369) CLAY COUNTY
COUNTY ROAD 76 OVER DRAG NASTY CREEK

PREDICTED SCOUR REPORT

Theoretical scour depths for the proposed bridge on this project were calculated internally by the "HEC-RAS" computer model using the methods shown in the FHWA publication, HEC no. 18, "Evaluating Scour at Bridges". General contraction scour and local pier scour were calculated for both the 100- and 500-year storms, as called for in this publication. The predicted scour depths at each intermediate bent of the proposed bridge will be provided to the Office of Materials and Research Soils Lab and the Bridge Structural Designer for inclusion in the analysis and design of the bridge foundations. Tables and calculations showing these predicted scour depths are included in this study.

Date:

Prepared By:

BR-0001-00(369) CLAY COUNTY
 COUNTY ROAD 76 OVER DRAG NASTY CREEK

10 YEAR STORM

CREEK FLOODS	NATURAL	EXISTING	PROPOSED
	CONDITIONS	BRIDGE	BRIDGE
		L = 108 (90)	L = 180 (60)

FLOODSTAGE AT FULL VALLEY	195.15	195.68	195.21
TOTAL DISCHARGE (CFS)	1970	1970	1970
DISCHARGE THRU BRIDGE (CFS)	-----	1970	1970
AREA OF BRIDGE OPENING(FT2)	-----	273	529
VELOCITY THRU BRIDGE (FPS)	-----	7.21	3.73
CHANNEL VELOCITY (FPS)	4.95	7.95	5.46
MAXIMUM BACKWATER (FT)	-----	1.63	0.68
WS ELEV APPROACH SECTION	195.96	197.59	196.64

100 YEAR STORM

CREEK FLOODS	NATURAL	EXISTING	PROPOSED
	CONDITIONS	BRIDGE	BRIDGE
		L=108 (90)	L = 180 (60)

FLOODSTAGE AT FULL VALLEY	196.89	196.97	196.98
TOTAL DISCHARGE (CFS)	3728	3728	3728
DISCHARGE THRU BRIDGE (CFS)	-----	3728	3728
AREA OF BRIDGE OPENING(FT2)	-----	405	747
VELOCITY THRU BRIDGE (FPS)	-----	9.20	4.99
CHANNEL VELOCITY (FPS)	5.67	10.51	7.86
MAXIMUM BACKWATER (FT)	-----	2.71	0.96
WS ELEV APPROACH SECTION	197.76	200.47	198.72

2 Year Floodstage Elev. = 193.23

BR-0001-00(369) CLAY COUNTY
 COUNTY ROAD 76 OVER DRAG NASTY CREEK

500 YEAR STORM

CREEK FLOOD	NATURAL	EXISTING	PROPOSED
	CONDITIONS	BRIDGE	BRIDGE
		L = 108 (90)	L = 180 (60)
=====	=====	=====	=====
FLOODSTAGE AT FULL VALLEY	198.05	198.13	198.18
TOTAL DISCHARGE (CFS)	5252	5252	5252
DISCHARGE THRU BRIDGE (CFS)	-----	5252	5252
AREA OF BRIDGE OPENING(FT2)	-----	428	930
VELOCITY THRU BRIDGE (FPS)	-----	12.26	5.65
CHANNEL VELOCITY (FPS)	6.18	14.16	9.37
MAXIMUM BACKWATER (FT)	-----	4.22	1.16
WS ELEV APPROACH SECTION	198.94	203.16	200.10

500 YEAR STORM

ABNORMAL LAKE POOL	NATURAL	EXISTING	PROPOSED
	CONDITIONS	BRIDGE	BRIDGE
		L=108 (90)	L = 180 (60)
=====	=====	=====	=====
FLOODSTAGE AT FULL VALLEY	200.23	200.17	200.23
TOTAL DISCHARGE (CFS)	5252	5252	5252
DISCHARGE THRU BRIDGE (CFS)	-----	5089	5252
DISCHARGE OVER ROAD (CFS)	-----	163	0
AREA OF BRIDGE OPENING(FT2)	-----	617	1238
VELOCITY THRU BRIDGE (FPS)	-----	8.51	4.24
CHANNEL VELOCITY (FPS)	4.06	10.86	7.25
MAXIMUM BACKWATER (FT)	-----	2.10	0.96
WS ELEV APPROACH SECTION	200.56	202.66	201.52

Section 4 - Sample Preliminary Bridge Layouts

Notes: The following pages contain sample preliminary bridge layouts.

Additional samples of preliminary bridge layouts can be obtained from GDOT's Bridge Hydraulics Section.

The preliminary bridge layout is to be drawn using the Department's Office of Bridge Design's Microstation Setup.

For consultant projects, a registered professional engineer is required to stamp and sign the preliminary bridge layout.

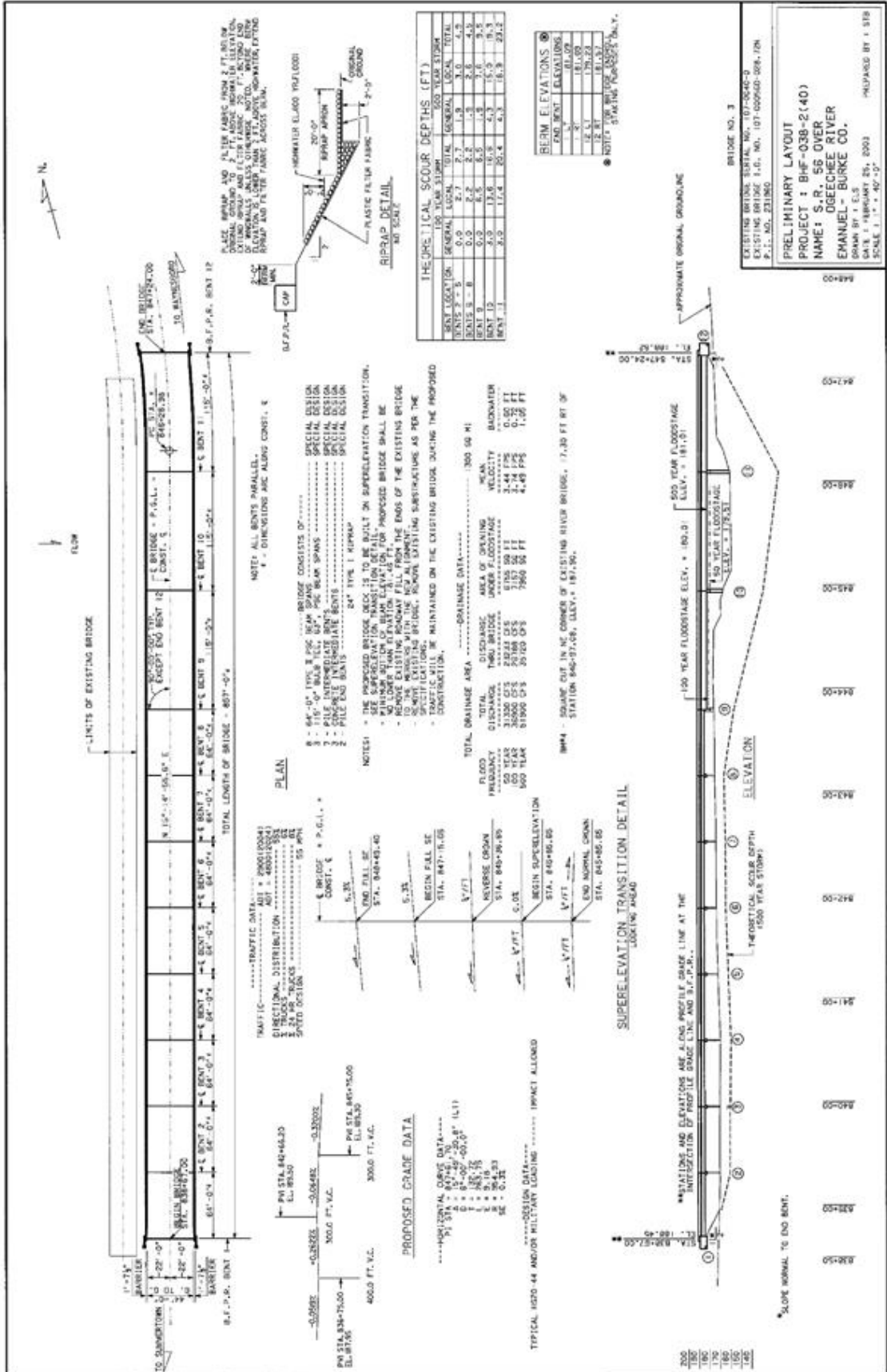

Section 5 – Risk Assessment

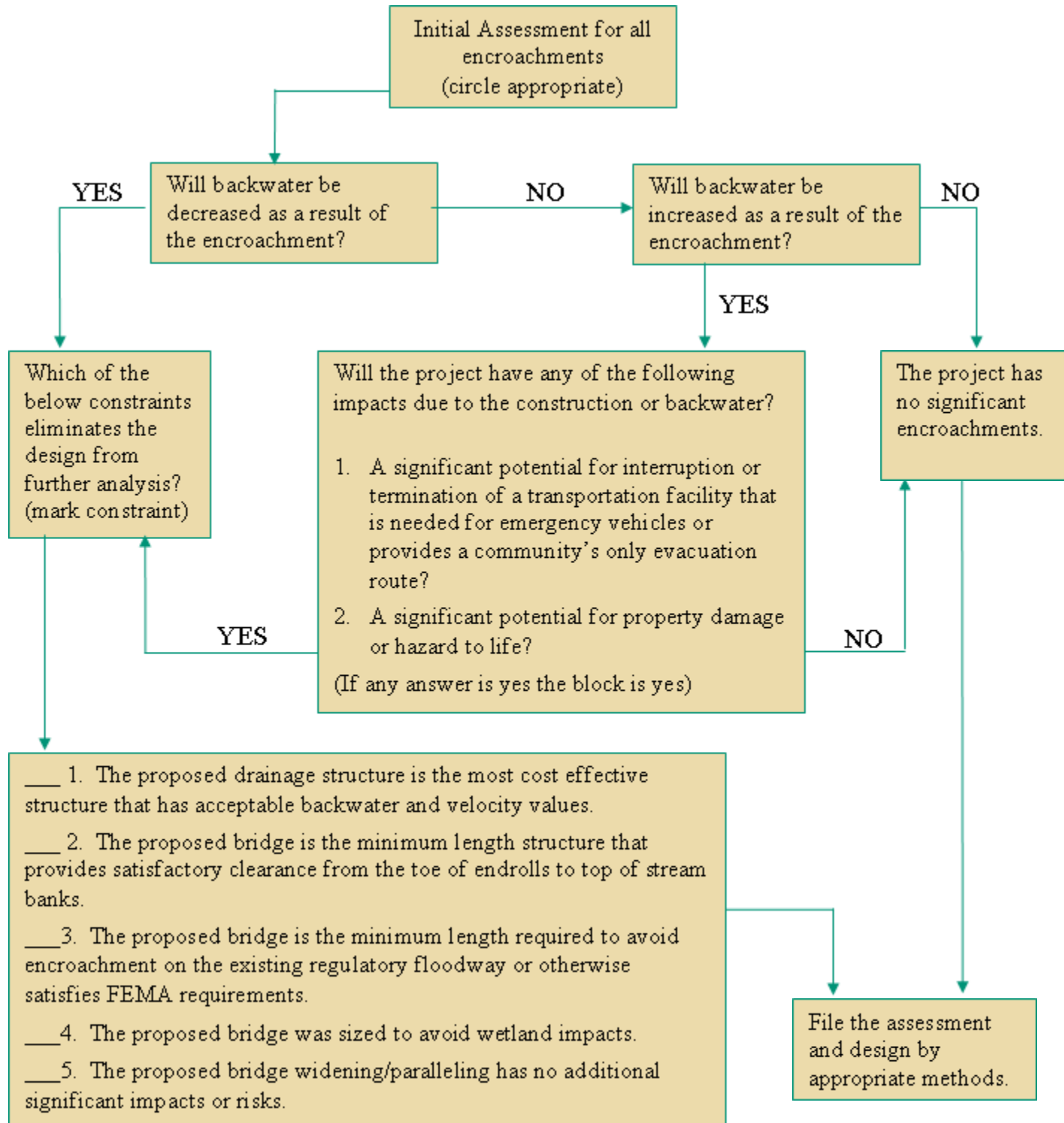

Section 6 – Sample Requests for Bridge Condition Survey

**SAMPLE REQUESTS FOR BRIDGE CONDITION SURVEY
AND BRIDGE DECK CONDITION SURVEY**

GEORGIA DEPARTMENT OF TRANSPORTATION

NO. 2 CAPITOL SQUARE
ATLANTA, GA 30334

BRIDGE DESIGN
INTERDEPARTMENT CORRESPONDENCE

FILE: _____ OFFICE: Atlanta, GA
PI No: _____ DATE: _____
ID No: _____

FROM:
TO: State Maintenance Engineer
Attn: State Bridge Maintenance Engineer

Subject: SALVAGE MATERIAL AND BRIDGE CONDITION SURVEY

This Office is preparing plans on the above mentioned project for the widening and/or paralleling of the bridge on _____ over _____. Please advise this Office as to what materials, if any, are to be salvaged and their proposed disposition.

Please survey the condition of the existing structure and make recommendations regarding any necessary rehabilitation.

Please insure that the existing pile penetration is adequate for this structure to be widened.

A location map is attached for your use.

This project is scheduled for the _____ letting.

Attachment

COPIES TO:

GEORGIA DEPARTMENT OF TRANSPORTATION

NO. 2 CAPITOL SQUARE
ATLANTA, GA 30334

BRIDGE DESIGN
INTERDEPARTMENT CORRESPONDENCE

FILE: _____ OFFICE: Atlanta, Ga.
PI No. _____ DATE: _____
ID No. _____

FROM:
TO: State Materials and Research Engineer
Attn: Assistant Paving Engineer

Subject: BRIDGE DECK CONDITION SURVEY

This Office is preparing plans on the above mentioned project for the widening and/or paralleling of the bridge on _____ over _____ (approximate milepost no. _____). Please survey the condition of the existing deck slab and make recommendations regarding any necessary rehabilitation.

A location map is attached for your use.

This project is scheduled for the _____ letting.

Attachment

COPIES TO:

Intentionally Left Blank

Appendix J. Geo-Hydrologic Assessment

1	Introduction	J-1
1.1	Objective	J-1
1.2	Safety	J-1
1.3	Definitions.....	J-1
1.3.1	Infiltration Rate	J-1
1.3.2	Percolation Rate.....	J-1
1.3.3	Permeability.....	J-2
1.3.4	Hydraulic Conductivity.....	J-2
2	Concept Report	J-3
3	PFPR Desktop Feasibility Screening	J-4
3.1	Description	J-4
3.1.1	Objective	J-4
3.2	Assessment of Site Suitability	J-4
3.2.1	Regional Geographic Factors	J-4
3.2.2	Site Layout and Geometric Constraints	J-6
3.2.3	Soils and Hydrogeologic Factors	J-6
3.2.4	Environmental Factors	J-6
3.2.5	Preliminary Site Classifications	J-6
3.2.6	USGS and GA EPD Geologic Maps	J-8
4	PFPR Field Study.....	J-12
4.1	Description	J-12
4.1.1	Objective	J-12
4.1.2	Characteristics.....	J-12
4.1.3	Outcome and Reporting.....	J-12
4.2	Field Exploration for Infiltration Trenches	J-13
4.2.1	Subsurface Investigation Methods.....	J-13
4.3	In-Situ Testing for Infiltration Trenches	J-15
4.3.1	Preferred Field Test Methods.....	J-15
4.3.2	Sampling and Testing Frequency	J-16
5	References	J-17
5.1	Test Standards	J-17
5.2	State and Federal Manuals	J-17
5.3	Miscellaneous Technical References	J-17
Attachment A: Worksheets.....		J-18

1 Introduction

1.1 Objective

The objective of this appendix to the GDOT Drainage Design for Highways Manual is to provide a guide to assess geotechnical and groundwater conditions as these factors affect the feasibility of infiltration-type stormwater Best Management Practices (stormwater infiltration BMPs).

Stormwater infiltration BMPs are those BMPs that are designed such that water leaves the BMP solely through infiltration into the underlying soil rather than discharging through an underdrain and outlet control structure. Infiltration testing and groundwater characterization is required to verify the infiltration rate of the underlying soil to ensure the BMP will drawdown in the specified design timeframe. Stormwater infiltration BMPs include infiltration trenches, capped enhanced dry swales, and capped bioretention basins.

Users of this guidance will be designers, consultants, or other individuals or companies that engage in design of roadways and other facilities for GDOT for which stormwater infiltration BMPs are required.

1.2 Safety

Field work and related soil and groundwater testing will be required at many sites. Attention to applicable Occupational Safety and Health Administration (OSHA) regulations and local guidelines related to earthwork and excavation is required. Digging and excavation should never be conducted without adequate notification through the Georgia One Call system (www.georgia811.com or 1-800-282-7411). Excavations should never be left unsecured or unmarked, and all applicable authorities, including GDOT, should be notified prior to any work.

The Design Team is responsible for ensuring the field evaluations discussed in this manual are conducted in compliance with OSHA 29CFR 1926. Field work must also adhere to local (City, County, etc.) and industry safety guidelines. Where OSHA and local guidelines are in conflict, the more stringent guideline shall apply. The Design Team is also responsible for ensuring traffic control is provided, if necessary, according to GDOT requirements.

1.3 Definitions

The following terminology and definitions are adopted for the purposes of this guidance.

1.3.1 Infiltration Rate

Infiltration rate is the rate at which water penetrates the ground surface and enters soil (distance/time). Infiltration rate is typically determined by the thickness of ponded water that flows downward into the soil over given period of time. Infiltration rate typically decreases with time from the beginning of infiltration, and eventually reaches a steady state as the soil becomes saturated. Infiltration rate is a function of soil layering, initial moisture deficit, soil suction, and the hydraulic conductivity of each layer.

1.3.2 Percolation Rate

Percolation rate is the rate at which water flows through a soil mass (distance/time) at hydraulic gradients on order of 1.0 or less. No distinction is made between the vertical and horizontal

components of the total percolation rate, thereby limiting the interpretation of percolation test results. The steady-state infiltration rate may be similar to percolation rate for a uniform soil mass but can vary significantly when soils near the ground surface differ from underlying soils at depth.

1.3.3 Permeability

Permeability is the term for the rate (distance/time) at which fluid flows through a soil mass when subjected to a given hydraulic gradient. Permeability values may be different in the horizontal, vertical, or an intermediate direction based on soil layering.

1.3.4 Hydraulic Conductivity

Hydraulic conductivity is the specific term for the rate (distance/time) at which liquid water flows through a soil mass when subjected to a given hydraulic gradient. As used in the applications addressed by this document, hydraulic conductivity is the same as permeability.

Hydraulic conductivity is typically reported in terms of its horizontal component (K_h) or vertical component (K_v) in most civil engineering projects, which can vary significantly depending on soil layering.

2 Concept Report

During the concept phase, information should be gathered to make an early, tentative judgment regarding whether stormwater infiltration BMPs are possibly feasible or clearly infeasible. Documentation developed during concept report includes the identification of the hydrologic soil group (HSG) on the project site using the NRCS Web Soil Survey or other comparable resource. Stormwater infiltration BMPs should only be considered further in areas with HSG A or B soils. The information should be indicated on MS4 Concept Report Summary.

3 PFPR Desktop Feasibility Screening

3.1 Description

Planning and consideration for stormwater infiltration BMPs should be implemented as early as practical in the project design process, ensuring that such planning is incorporated throughout the project. To this end, two stages of evaluation are recommended to determine site-specific suitability for stormwater infiltration BMPs:

- PFPR Desktop Feasibility Screening - A preliminary screening and planning phase during which the feasibility is assessed in consideration of a global set of site physical conditions and constraints. To streamline the coordination process, it is recommended to contact the Water Resources Group before beginning J-1. Direct coordination with the Water Resources is required if an infiltration trench is determined to be feasible prior to submittal of the draft Post Construction Stormwater Report.
- PFPR Field Study (see Section 4) - If an infiltration trench is proposed, a more rigorous analyses – including site specific testing and data gathering – is used to develop a design for the trench. PFPR Field Study is not needed for capped enhanced dry swales or capped bioretention basins as construction will perform testing if PFPR Desktop Feasibility Screening indicates that infiltration is potentially suitable.

3.1.1 Objective

The objectives of the feasibility screening phase are twofold, namely:

- To identify the potential impact of site physical conditions and constraints on the potential to implement infiltration BMPs; and
- To determine whether infiltration BMPs should be given further consideration. If infiltration BMPs are found to be unsuitable, do not proceed with PFPR Field Study.
- Outcome and Reporting

Worksheet J-1 in Appendix F, *PFPR Screening for Stormwater Infiltration*, is provided as a resource to the Design Team to help assess the feasibility of stormwater infiltration BMPs. This worksheet is required to be submitted for BMPs that pass concept level infiltration feasibility screening.

3.2 Assessment of Site Suitability

3.2.1 Regional Geographic Factors

Georgia has five distinct physiographic provinces, each of which present different challenges to the investigation and evaluation of subsurface conditions for design of stormwater structures.

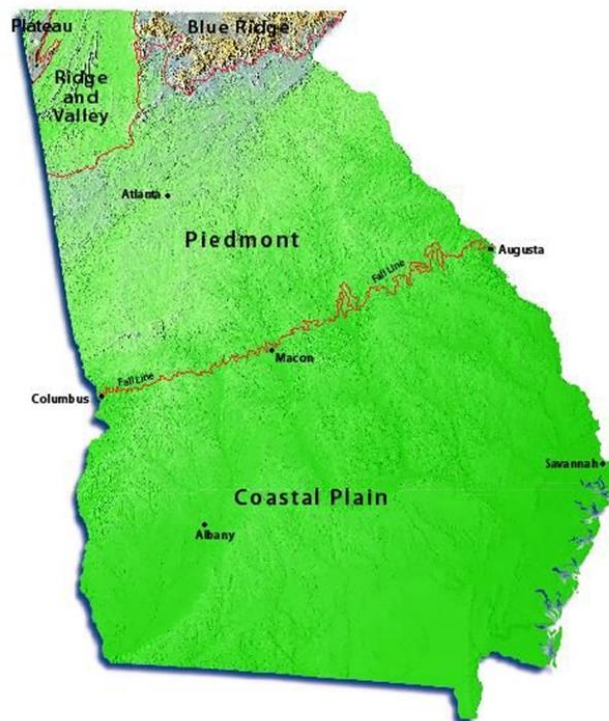

Figure 3-1. Georgia's Physiographic Provinces

- Coastal Plain - The Coastal Plain is characterized by relatively flat, low topographic relief and relatively higher groundwater levels. Development of stormwater infiltration BMPs in this physiographic region may face challenges related to high groundwater level and relatively heterogeneous subsurface conditions.
- Piedmont - Development of stormwater infiltration BMPs in this physiographic region will face challenges posed by the heterogeneous residual soils that lie above the relatively impervious bedrock. The occurrence of sound rock can be difficult to predict.
- Blue Ridge - Development of stormwater infiltration BMPs in this physiographic region may face challenges posed by near surface, relatively impervious bedrock, as well as concerns regarding embankment stability and landslides. Groundwater flow can be complex, occurring in the soil-rock interface and/or in fractures within rock masses.
- Ridge and Valley - Like the Blue Ridge, the region is characterized by high ground surface elevations and steep slopes. By virtue of its geology and topography, the area is well known for historic problems with landslides and ground collapse due to karst-related sinkholes.
- Appalachian Plateau - Development of stormwater infiltration BMPs in this physiographic region will face challenges similar to those posed by the Ridge and Valley. Infiltration may be limited by relatively impervious bedrock. Uncontrolled, infiltration can create hazards to embankment stability, or contribute to landslides. Groundwater flow in the uplands portion of this region can be complex, occurring in the soil-rock interface and in fractures within rock masses.

3.2.2 Site Layout and Geometric Constraints

Planning for stormwater infiltration BMPs must include careful consideration of site-specific constraints. The constraints listed below may make certain structural BMPs infeasible for all or a portion of a roadway project.

1. Site Layout. Available ROW, steep slopes, embankment stability, high water table, proximity to protected waters, construction and/or maintenance access.
2. Geometric Constraints. Prospective BMP locations that are near retaining walls or foundations must ensure that these structures are designed can withstand the purpose-built forces they resist plus any additional load imposed water infiltration (for example, potential increases in lateral pressures and potential reductions in soil strength).

3.2.3 Soils and Hydrogeologic Factors

The PFPR desktop assessment includes a review of publicly available sources to identify potential infiltration issues related to the site physical setting.

- Karst Topography (**Figure 3-2**)
- Acid Producing Rock (**Figure 3-3**)
- Landslide Prone Areas (**Figure 3-4**)
- Potentially expansive soils (**Figure 3-5**)
- Groundwater Recharge area (**Figure 3-6**)

3.2.4 Environmental Factors

PFPR desktop assessment (and future field assessments, if needed) must consider potential environmental impacts related to stormwater infiltration. These effects can include, but are not limited to, the following:

- Areas of contaminated soil or groundwater;
- Hazardous sites;
- Nearby areas of active environmental remediation;
- Groundwater recharge areas;
- Public and private well fields;
- Actively operating underground storage tanks (USTs); and
- Brownfield sites.

3.2.5 Preliminary Site Classifications

3.2.5.1 *Unsuitable*

A site is considered unsuitable for infiltration BMPs when any of the following conditions are present in the areas where infiltration BMPs are planned:

Table 3-1. BMP Suitability According to Physical Setting

Physical Setting	Unsuitability Conditions
Geologic	Located in an area of Karst Topography, see Figure 3-2
	Located in an area of Acid Producing Rock, see Figure 3-3
	Located in Landslide Prone Areas see Figure 3-4
Soils	Hydrologic Soil groups C or D
	Located in an area of potentially expansive soils, see Figure 3-5 .
Groundwater	Located in Identified Groundwater Recharge area, see, Figure 3-6 .
Environmental	Areas with contaminated soil or groundwater.
	Near brownfield sites or active remediation sites.
	Near hazardous sites.
	Near existing underground storage tank (UST) sites.
Structural	Within 50 feet of structure foundation (e.g., bridge, retaining wall, building, etc.).
	Within 20 feet of buried utilities.
Topographic	Preconstruction slopes outside allowable limits in Chapter 10.6 of this manual.
	BMP footprint within 25 feet of the existing crest or toe of a slope steeper than 4:1.
	BMP footprint within a distance 1.5 times the height of the nearest fill slope steeper than 4:1.
	Less than one-foot elevation difference between inflow and outflow locations.
	Constructed within on or near fill sections.

3.2.5.2 Potentially Suitable

This classification indicates the site is potentially well-suited for infiltration BMPs. In general, this classification is designated for sites found to be absent of the concerns discussed in previous site suitability classifications, but additional field study is needed before a full infiltration BMP (infiltration trench) can be recommended.

3.2.6 USGS and GA EPD Geologic Maps

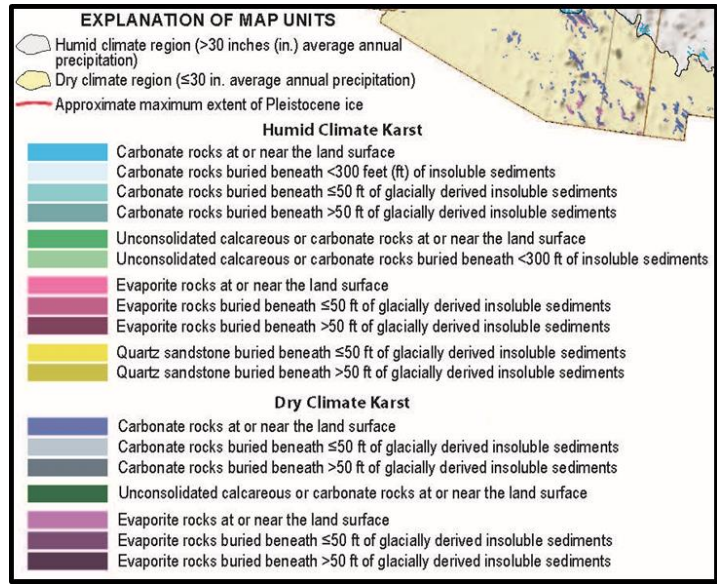
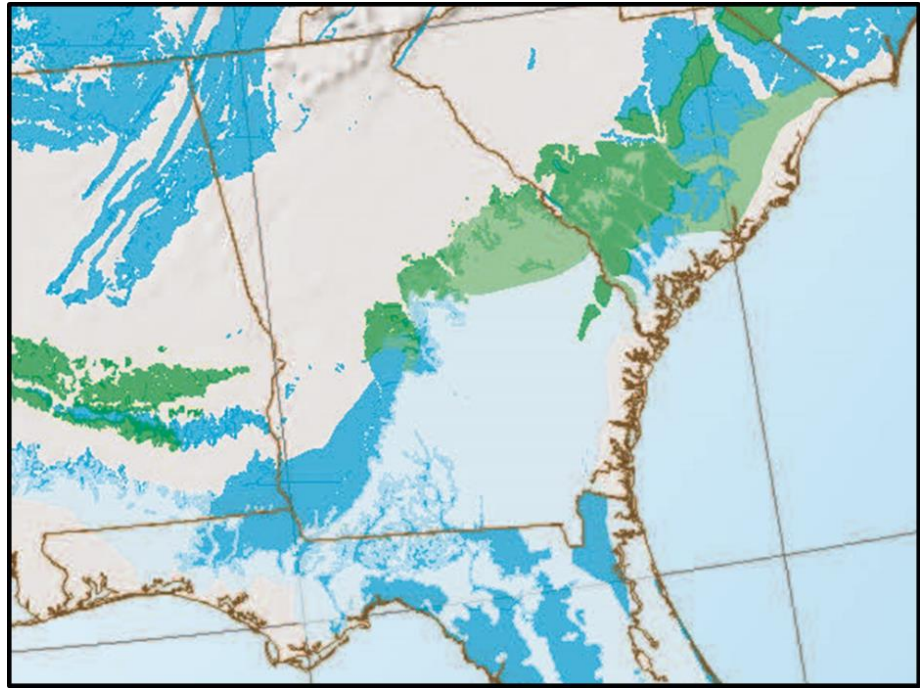

Figure 3-2. Approximate Distribution of Karst and Potential Karst in the Southeastern U.S. (source: USGS 2014)

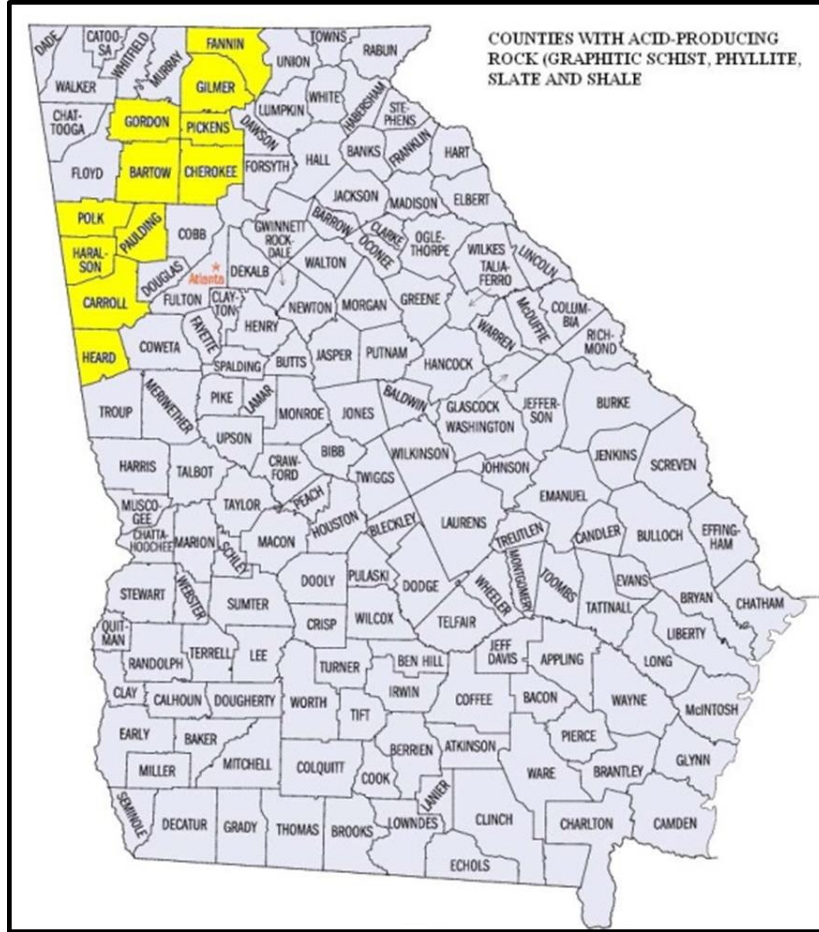

Figure 3-3. Distribution of Acid-Producing Rock in Georgia (source: GDOT 2016).

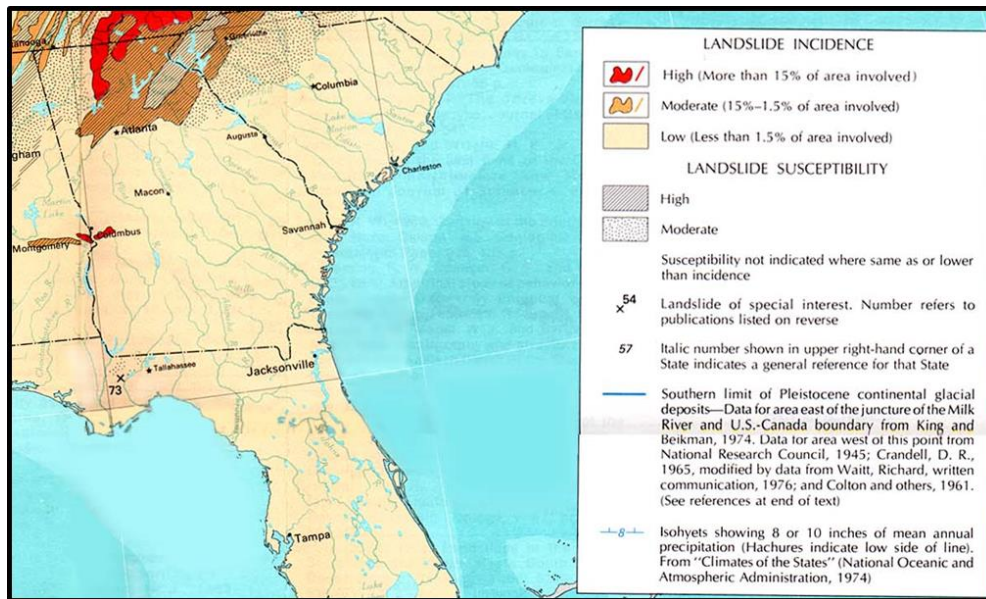

Figure 3-4. Overview of Landslide Risk in Georgia (source: USDOI 1982)

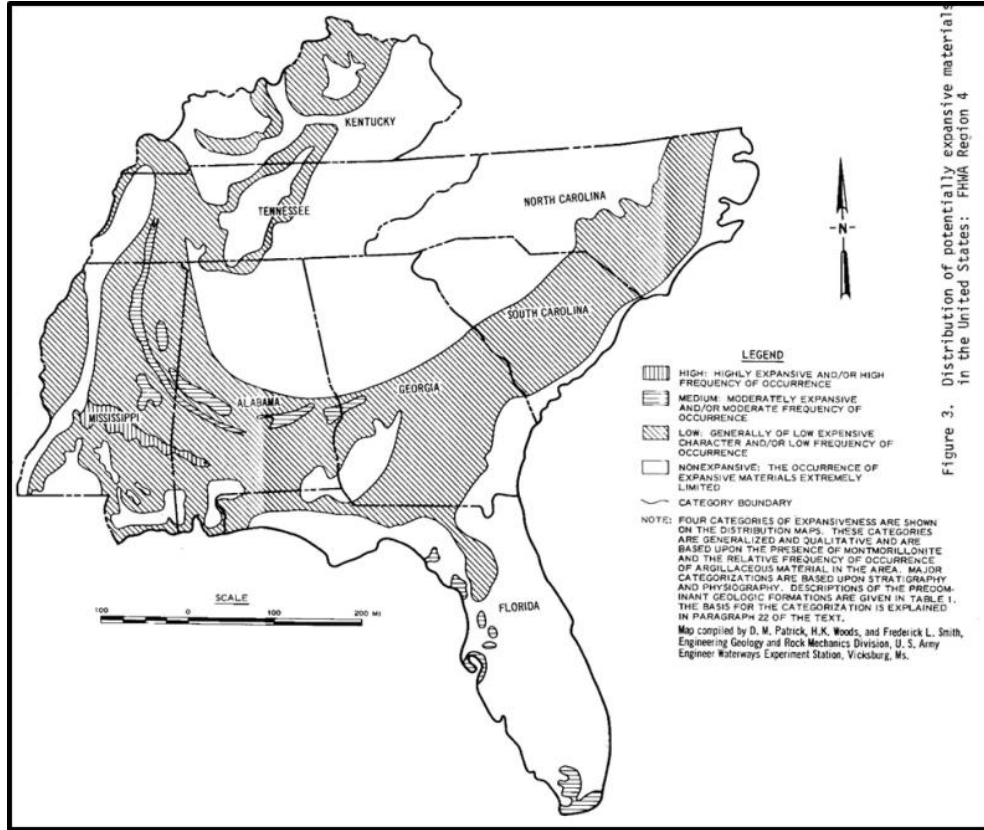

Figure 3. Distribution of potentially expansive materials in the United States: FHWA Region 4

Figure 3-5. Approximate Distribution of Expansive Soils in the Southeastern U.S. (source: FHWA 1975)

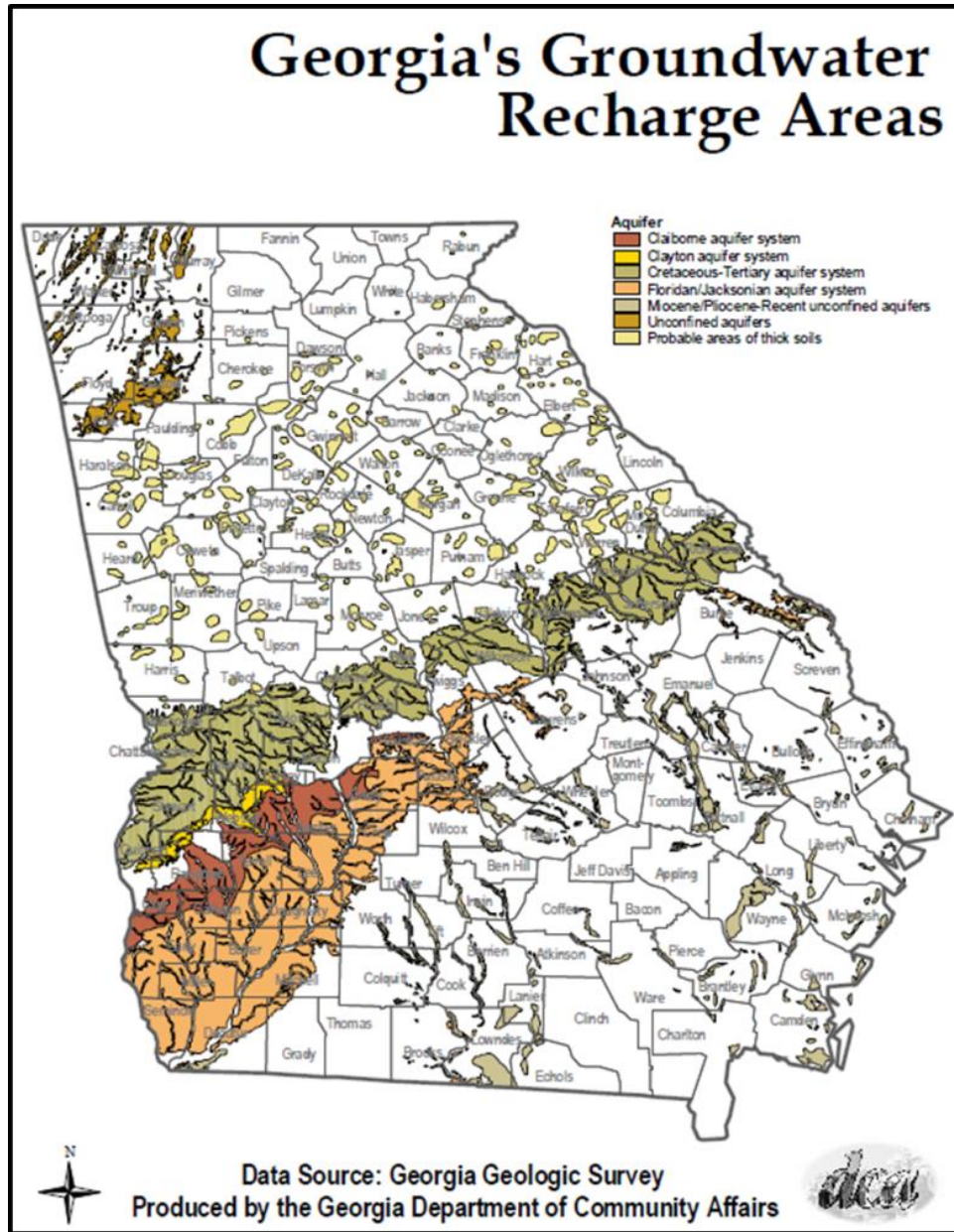

Figure 3-6. Georgia's Groundwater Recharge Areas
(source: Georgia Geologic Survey)

<http://www.georgiaplanning.com/documents/atlas/gwrecharge.pdf>

4 PFPR Field Study

4.1 Description

4.1.1 Objective

PFPR field study applies only to BMP locations where infiltration is potentially feasible as determined from the Desktop Feasibility Screening. The objective of the PFPR Field Study obtain information that is adequately site-specific and reliable to support design (e.g., depth to groundwater, design infiltration rate; analysis of geotechnical risks and mitigation approaches). The PFPR Field Study is only required for sites with proposed infiltration trenches. Other infiltration BMPs have backup drainage systems, and thus, do not require field study.

4.1.2 Characteristics

This phase is generally performed as part of Preliminary Design in GDOT's PDP framework. The PFPR Field Study consists of two elements, often performed contemporaneously:

- A site-specific geotechnical exploration, hereafter termed "Field Exploration" and
- In-situ Testing.

If infiltration is determined to be feasible for infiltration trenches in PFPR Desktop Screening, In-Situ Testing will be conducted at the same time as PFPR Field Exploration. It is the responsibility of the Design Team to acquire the services of a geo-professional to perform the PFPR Field Study. These components are described in further detail in the following sections.

4.1.3 Outcome and Reporting

The outcome of this phase should be a more rigorous assessment of feasibility, with selection and layout of infiltration trenches, as supported by location specific testing, integrated with project design.

Worksheet J-2 provides guidance for preparation of this PFPR Infiltration Trench Suitability Field Study Report to determine if an infiltration trench is feasible. The report will be submitted to ODPS for review. At a minimum, this report should include the scope of documentation described below.

1. Part 1. Introduction and Summary. Describe the objective and scope of the PFPR Field Study. The report should address requirements for stormwater infiltration as understood at this level of design. The findings of the PFPR Field Study should be summarized .
2. Part 2. Site-Specific Evaluation. The findings of the site-specific assessments of subsurface conditions and the infiltration/percolation rates and capacities should address the site-specific considerations listed below.
 - i. Geology of the site area, with a focus on its potential influence on the project requirements for infiltration.
 - ii. Surface and subsurface soil and geologic conditions as they may affect infiltration and migration of water.
 - iii. The depth to groundwater, groundwater quality, and likely variations in the high seasonal groundwater elevations.
 - iv. Results of subsurface exploration and laboratory testing should be tabulated in the body of the report. Records of the testing, including raw data, should be appended.

- v. Results of infiltration/percolation testing should be tabulated in the body of the report. Records of the testing, including raw data, should be appended.
- vi. To the extent the work considers stormwater at various BMP locations, provide discussion regarding infiltration rates or capacities in each sub-basin.
- vii. Provide a concluding opinion regarding whether or not the proposed onsite stormwater infiltration trench can be implemented without damage to GDOT or adjacent properties.
- viii. Provide a judgment regarding site suitability for infiltration trenches.

The PFPR Infiltration Trench Suitability Field Study Report should be supplemented, as appropriate by plans, graphics, photographs, etc. that will enable users of the report to clearly understand the text. The PFPR Infiltration Trench Suitability Field Study Report shall be submitted to ODPS for review. Include the approved PFPR Infiltration Trench Suitability Field Study Report as an appendix in the MS4 Post-Construction Stormwater Report for infiltration trenches which are considered potentially suitable by the PFPR Desktop Feasibility Screening.

4.2 Field Exploration for Infiltration Trenches

The Field Exploration should develop site-specific stratigraphy and soil properties in the areas of prospective infiltration trenches. The Field Exploration should include soil borings and/or test pits ("exploration points") extended to at least 10 feet beyond the expected depths of the infiltration trenches.

4.2.1 Subsurface Investigation Methods

Either test pits and/or soil borings must be undertaken for characterization of the subsurface at the location of prospective infiltration trenches. These tools each allow visual observation of the soil horizons and overall soil conditions at an infiltration location. A sufficient number of carefully logged and sampled borings or test pits should be conducted such that the soil conditions are understood both horizontally and vertically in the portion of the site under consideration for infiltration trenches. Laboratory testing of representative samples may be used to supplement descriptions of the subsurface.

In general, the use of test pits is much preferred over soil borings as a field investigation tool. Test pits allow clear visual observation of the subsurface, while such clarity is narrowly limited in a soil boring. The soil boring does not allow observation of the soil horizons in situ, requiring qualitative judgment (e.g., the indications of the drilling rate, soil return from augers, etc.) to assess the subsurface. Certain circumstances (for example, the depth to the base of the planned BMP) early in the design process may drive the use of the soil borings.

Laboratory testing of representative samples may be used to supplement descriptions of the subsurface. However, such testing should be limited only to that necessary to support classification of the subsurface. The use of laboratory testing to establish infiltration rates of the BMP location is not acceptable.

Table 4-2 summarizes the utility of test pits, soil borings and laboratory testing as tools for determining subsurface conditions and infiltration rates at BMP locations.

Table 4-2. **Utility of Test Pits, Soil Borings and Laboratory Testing for Assessment of the Subsurface.**

Tool	General Applicability	Capabilities	Limitations
Test Pits	Bulk sampling, <i>in situ</i> testing, visual inspection.	Fast, economical, able to access more difficult sites. Typically extendable to ±8 feet depth.	Bench for unbraced personnel access if D > 4 feet, stability affected by groundwater. Limited undisturbed sampling.
Soil Borings	General determination of the soil profile to depths in excess of >10 feet with <i>in situ</i> testing and undisturbed sampling	Allows <i>in situ</i> testing, undisturbed and disturbed soil sampling	Limited access. Casing obscures visual inspection. Penetration can be limited by hard soils, cobbles or boulders.
Laboratory Testing	Quantitative supplement to the logging of test pits and borings.	ASTM classification of soil strata.	May be used as a supplement only. Laboratory testing to establish infiltration rates is not acceptable.

4.2.1.1 Test Pits

Where applicable, test pits are the preferred survey method due to improved visual representation of subsurface soil types, layering, and groundwater. A test pit excavation allows visual observation of the soil horizons and overall soil conditions both horizontally and vertically in that portion of the site.

It is important that the test pit provide information related to conditions at the bottom of the proposed infiltration trench. The designer is cautioned regarding the proposal of infiltration trenches that are significantly lower than the existing topography. The suitability for infiltration may decrease, and risk factors are likely to increase.

The designer and contractors should minimize grading and earthwork to the extent practical to reduce site disturbance and compaction so that a greater opportunity exists for testing and stormwater management in subsequent phases.

4.2.1.2 Soil Borings

Soil borings provide limited sampling of the subsurface relative to test pits and are generally discouraged as a primary investigation options for infiltration purposes. Additionally, production rates for soil borings are typically less than that for test pits. However, in cases where test pits cannot be performed due to site constraints or cannot be sampled to the required depth of investigation, soil borings are acceptable as a primary exploration method. For example, soil borings should be used where proposed finished grade is significantly below existing grade and test pits are unable to sample the soil zone of interest.

4.2.1.3 Allowance for Alternative Testing Procedures

Some laboratory testing methods can be used to assess a soil's suitability for infiltration for early screening. In certain instances, laboratory testing may be used for verification.

For instance, if the infiltration trenches are not located precisely over the test locations, alternate testing or investigations can be used to verify that the soils are the same as the soils that yielded the earlier test results. However, designers should document these verification test results or investigations.

Decisions to utilize laboratory testing should be made by the geo-professional.

4.2.1.4 Index Testing

Laboratory index testing on select samples collected during the field investigation may be performed to confirm field classifications and to aid in the characterization of subsurface stratigraphy. Laboratory index testing should be performed on each different soil type identified in the field logging. Determination of the frequency of testing is the responsibility of the Design Team and may vary significantly depending on geologic formation and expected variability. Index tests should include the following:

- Moisture Content (ASTM D2216);
- Atterberg Limits (ASTM D4318);
- Particle-size distribution (ASTM D422); and,
- Soil classification after ASTM D2488.

4.2.1.5 Density Testing

Undisturbed sampling of soil (for example, thinwall tube sampling after ASTM D1587) may be undertaken in certain instances.

4.2.1.6 Laboratory Hydraulic Conductivity

Laboratory hydraulic conductivity testing on relatively undisturbed thin-wall ('Shelby tube') samples can be performed as part of the screening analysis. Such tests may be preferred in instances where limited site access or other factors that exist limit the feasibility of field infiltration tests.

Laboratory testing methods for preliminary design purposes may include ASTM D2434 or ASTM D5084. However, it is recommended that in-situ field tests be performed whenever practical.

4.3 In-Situ Testing for Infiltration Trenches

4.3.1 Preferred Field Test Methods

In-situ infiltration/percolation testing will provide quantitative data regarding in-situ hydraulic conductivity of soils. These data can be used to confirm and/or calibrate estimates developed from published correlations with grain-size, plasticity, and/or geologic formation provided in the Field Exploration. Selection of a method of in-situ testing is within the Designer's and Geo-professional's discretion. Among other factors, the choice of in-situ testing method will depend on:

- The confidence level that site soils are suitable for infiltration trenches; and
- Certainty of the proposed infiltration trench footprint and depth.

Field testing methodologies preferred by GDOT include:

- Double-Ring Infiltrometer tests (ASTM D3385 or 5093);
- Single-Ring Infiltrometer (modified from ASTM D5126);
- Borehole Infiltration Test (ASTM D6391); and,
- Percolation tests (such as for on-site wastewater systems).

See Table 6-1 for a summary of the methods.

4.3.2 Sampling and Testing Frequency

The PFPR Field Study should include at least one (1) exploration point per proposed infiltration trench. For larger infiltration areas (i.e. more than 10,000 square-feet [SF] in plan or more than 150 linear-feet [LF] in length), multiple exploration points should be evenly distributed within the BMP area at the rate of one (1) additional test per 10,000 SF of infiltration trench area or every 100 LF of infiltration trench length, whichever is more frequent. Exploration points should be located within the footprint of proposed infiltration trench if practicable, but no greater than 50 feet beyond if preconstruction site constraints are present. Table 4-1 summarizes the recommended minimum testing frequencies.

Table 4-1. Recommended Minimum Testing Frequency.

Primary Method for Estimating Infiltration Rate	Minimum Number of Tests / Data Points per Infiltration Trench	Minimum Number of Borings / Test Pits per Infiltration Trench
Single-Ring Infiltrometer (where applicable)	2	1
Double-Ring Infiltrometer	2	1
Borehole Infiltration Test	2	1
Percolation Test	4	1
Grain-size Correlations (Site-Specific Lab Data)	4	1

5 References

5.1 Test Standards

ASTM D 3385 – 03. Standard Test Method for Infiltration Rate of Soils in Field Using Double-Ring Infiltrometer. West Conshohocken, PA. 2003.

ASTM D 5126 – 16. Standard Guide for Comparison of Field Methods for Determining Hydraulic Conductivity in Vadose Zone. West Conshohocken, PA. 2016.

ASTM D 5093 – 02. Standard Test Method for Field Measurement of Infiltration Rate Using a Double-Ring Infiltrometer with a Sealed-Inner Ring. West Conshohocken, PA. 2002.

ASTM D 6391 – 06. Standard Test Method for Field Measurement of Hydraulic Conductivity Limits of Porous Materials Using Two Stages of Infiltration from a Borehole. West Conshohocken, PA. 2006.

U.S. Department of the Interior. A Field Method for Measurement of Infiltration. Geological Survey Water-Supply Paper 1544-F. 1991.

U.S. Department of the Interior, Bureau of Reclamation, "Procedure for Performing Field Permeability Testing by the Well Permeameter Method (USBR 7300-89)," in Earth Manual, Part 2, Materials Engineering Branch Research and Laboratory Services Division, 3rd edition, Denver, Colorado, 1990.

5.2 State and Federal Manuals

Georgia Department of Transportation ("GDOT 2016"). Geotechnical Manual. Updated June 24, 2016.

Federal Highway Administration ("FHWA 1975"). A Review of Engineering Experiences with Expansive Soils in Highway Subgrades. BY D.R. Snethen and others. June 1975.

5.3 Miscellaneous Technical References

Chapuis RP. 2004. Predicting the Saturated Hydraulic Conductivity of Sand and Gravel Using Effective Diameter and Void Ratio. Can Geotech J 41: 787-795.

Georgia Geologic Survey. Georgia's Groundwater Recharge Areas. <http://www.georgiaplanning.com/documents/atlas/gwrecharge.pdf>

Terzaghi, K. and Peck, R.B., (1967), "Soil Mechanics in Engineering Practice", John Wiley and Sons, 729p.

US Department of the Interior ("USDOI 1982"). Landslide Overview Map of the Conterminous United States. Geological Survey Professional Paper 1183. 1982.

USGS ("USGS 2014"). Karst in the United States: A Digital Map Compilation and Database. By David J. Weary and Daniel H. Doctor. Open-File Report 2014-1156. 2014.

Attachment A: Worksheets

PFPR Screening for Stormwater Infiltration				Worksheet J-1		
Outfall Basin Name:						
Category	Parameter	Yes	No	Not Sure	Data Source / Reference	Comments / Justification
Geologic	Located in area of Karst Topography				Figure 3-2	
	Located in area of Acid Producing rock				Figure 3-3	
	Located in Landslide prone area				Figure 3-4	
Soils	Hydrologic Soil groups C or D				<u>NRCS Soil Survey</u>	
	Located in an area of potentially expansive soils?				Figure 3-5	
Groundwater	Located in Identified Groundwater Recharge area				Figure 3-6	
Environmental	Areas of contaminated soil or groundwater					
	Near a hazardous site?				<u>GA EPD Hazardous Site Inventory</u>	
	Near brownfield sites or active remediation sites				<u>GA EPD Brown Fields</u>	
	Near an existing underground storage tank (UST) site				<u>GA EPD USTs</u>	
Structural	Within 50 feet of structure foundation (e.g., bridge, retaining wall, building, etc.)?					
	Within 20 feet of buried utilities					
Topographic	Preconstruction slopes outside allowable limits in Chapter 10.6 of this manual					
	BMP footprint within 25 feet of the existing crest or toe of a slope steeper than 4H:1V					
	BMP footprint within a distance 1.5 times the height of the nearest fill slope steeper than 4:1					
	Less than one-foot elevation difference between inflow and outflow locations					
	Constructed within on or near fill sections					

Desktop Site Classification	Mark one (X)
Unsuitable	
Potentially Suitable	

PFPR Infiltration Trench Suitability Field Report		Worksheet J-2						
Section	Content							
1	Introduction							
	<p>A. <u>Project Description</u>. Provide a description of the subject project, with reference to the potential need for infiltration trenches. Establish the design phase addressed by the report.</p> <p>B. <u>Objective of This Study</u>. Provide a succinct statement of the objective of the work reported.</p> <p>C. <u>Abstract of Current Phase Assessment</u>. Provide a summary of the PFPR Field Study findings and recommendations.</p> <table border="1" style="margin-left: 40px;"> <thead> <tr> <th style="text-align: center;">Field Study Site Classification</th> <th style="text-align: center;">Mark one</th> </tr> </thead> <tbody> <tr> <td style="text-align: center;">Unsuitable</td> <td style="width: 50px;"></td> </tr> <tr> <td style="text-align: center;">Suitable</td> <td></td> </tr> </tbody> </table>		Field Study Site Classification	Mark one	Unsuitable		Suitable	
Field Study Site Classification	Mark one							
Unsuitable								
Suitable								
2	Site Description							
	<p>A. <u>Regional Geology</u>. Provide a description of geologic setting of the site, with focus on influence of the near surface geology on the project requirements for infiltration. This review may rely on the findings of previous studies. Graphics should be used to support discussion.</p> <p>B. <u>Site Conditions</u>.</p> <ul style="list-style-type: none"> a. <u>Surface Conditions</u>. Utilizing available survey and preliminary project documentation, provide description of the site. A description of the site surface topography should be provided in detail, providing maps to support this discussion. Utilize graphics/maps/photos, as appropriate, to discuss other relevant descriptions of the site. b. <u>Subsurface</u>. Provide a description of the near surface soil and rock units, taking care to distinguish between naturally occurring deposits and areas of artificial fill. If fill is planned for the site and may affect stormwater infiltration trenches, such fill should be noted. Support descriptions of the subsurface by the indications of soil borings, test pits, etc. If relevant, utilize the indications of laboratory testing to support soil descriptions. c. <u>Groundwater</u>. Describe groundwater elevation across the site, addressing any apparent groundwater gradient. Address historical high groundwater levels. d. <u>Surface Water</u>. Describe surface water to the degree it may affect the site or has historically affected the site. Documentation from flood mapping should be cited. 							

Worksheet J-2 Page 2 of 3

Section	Content
3	Subsurface Exploration Or Laboratory Testing
	<p>A. <u>Subsurface Exploration</u>. Provide a description of the scope of the field subsurface exploration. Summarize the types of testing conducted, with references to appendices that provide details (boring logs, logs of test pits, etc.). This discussion must be supported by at least one figure that shows the location of all field exploration points. Field exploration points must be described in terms of GPS locations and elevation.</p> <p>B. <u>Laboratory Testing</u>. Provide a description of the scope of laboratory testing. Summarize the types of testing conducted, including ASTM references. Tabulate the findings of laboratory testing in summary form in the body of the report. Details regarding laboratory testing should be appended.</p>
4	Infiltration / Percolation Testing
	<p>A. <u>Summary of Testing</u>. Provide a description of the scope of infiltration and/or percolation testing undertaken for this study.</p> <p>Utilize tables and graphics to depict the locations of the various types of testing conducted. Discussion should also be provided regarding the reasons for selection of testing methodologies.</p> <p>Discussion regarding the testing should reference appendices that provide details of all work, including test methodologies, etc. This discussion must be supported by at least one figure that shows the location of all field exploration points. Field exploration points must be described in terms of GPS locations and elevation.</p> <p>B. <u>Discussion of Results</u>. Provide discussion regarding the indications of the testing. Utilize tables for presentation of specific recommended design parameters for specific stormwater infiltration trenches.</p> <p>As appropriate, distinguish recommended design values for different subsurface soil units.</p>

Worksheet J-2 Page 3 of 3

Section	Content
5	Discussion and Recommendations
	<p>A. <u>Discussion</u>. Utilizing the information developed from this assessment review in summary the data developed in Sections 1-4.</p> <p>B. <u>Recommendations</u>. Provide recommendations from a geologic and geotechnical perspective for implementation of infiltration trenches as addressed by the subject report. These recommendations should address, at a minimum, the site considerations listed below.</p> <p style="padding-left: 40px;">1. Design Basis Infiltration Rates. Provide design basis infiltration rates for specific soil units for specific infiltration trenches. If the infiltration rate is less than 0.5/hr, infiltration trenches are unsuitable.</p>
6	References
	Provide a listing of references used in preparation of the report.
Appendices	Project Documentation
	Attach records of borings, test pits, laboratory testing, field testing (if applicable), etc. as separate appendices to Worksheet J-2.

Intentionally Left Blank