

**Super
T SERIES**

VARIOUS PATENTS APPLY

Equipped With
ERADICATOR
Solids Management System

Self Priming Centrifugal Pump

Model T2C61SC-B

Size 2" x 2"



PUMP SPECIFICATIONS

Size: 2" x 2" (51 mm x 51 mm) NPT - Female.

Casing: Gray Iron 30.

Maximum Operating Pressure 79 psi (545 kPa).*

Semi-Open Type, Two Vane Impeller: Stainless Steel 316.

Handles 1 1/2" (38,1 mm) Diameter Spherical Solids.

Impeller Shaft: Stainless Steel 17-4 PH.

Shaft Sleeve: Stainless Steel 316.

Replaceable Self-Cleaning Wear Plate: Stainless Steel 316.

Adjustable Back Cover Plate: Gray Iron 30; 20 lbs. (9 kg).

Removable Inspection Cover Plate: Gray Iron 30; 3.2 lbs. (1,45 kg.).

Seal Plate: Stainless Steel 316.

Flap Valve: Neoprene ^w/Steel Reinforcing.

Bearing Housing: Gray Iron 30.

Radial Bearing: Open Single Row Ball.

Thrust Bearing: Open Double Row Ball.

Bearing and Seal Cavity Lubrication: SAE 30 Non-Detergent Oil.

Flanges: Gray Iron 30.

Gaskets: Buna-N, Vegetable Fiber, Cork and Rubber.

O-Rings: Buna-N.

Internal Wetted Hardware: Stainless Steel 316.

External Hardware: Standard Plated Steel.

Stainless Steel 316 Pressure Relief Valve.

Bearing and Seal Cavity Oil Level Sight Gauges.

Optional Equipment: Automatic Air Release Valve. 120V/240V

Casing Heater. High Pump Temperature Shutdown Kit.

CD4MCu Stainless Steel Seal Plate, Wear Plate and Impeller.

Gray Iron 30 Suction and Discharge Spool Flanges:

2" ASA (**Specify Model T2A61-B /F**).

50 mm DIN 2527 (PN 16) (**Specify Model T2A61-B /FM**).

**Consult Factory for Applications Exceeding Maximum Pressure and/or Temperature Indicated.*

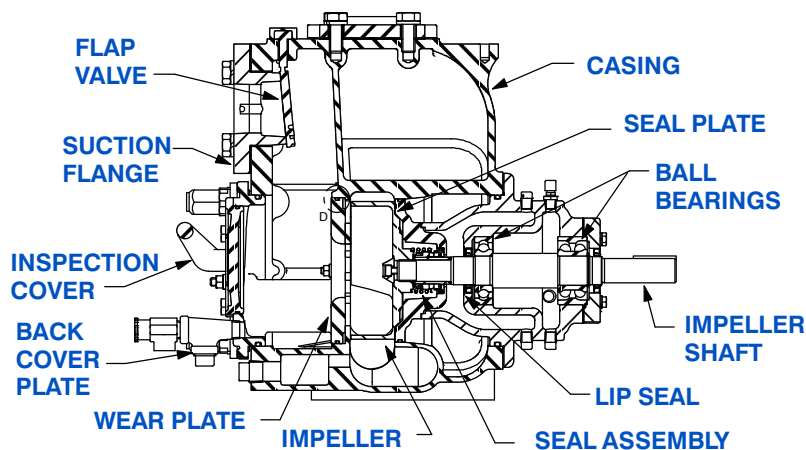
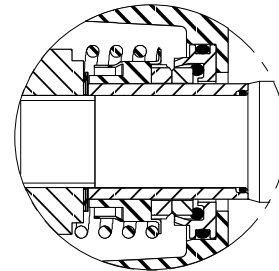

SEAL DETAIL

Mechanical, Oil-Lubricated, Double Floating, Self-Aligning. Silicon Carbide Rotating and Stationary Faces. Stainless Steel 316 Stationary Seat. Fluorocarbon Elastomers (DuPont Viton[®] or Equivalent). Stainless Steel 18-8 Cage and Spring. Maximum Temperature of Liquid Pumped, 160°F (71°C).*

GR
GORMAN-RUPP
PUMPS

GORMAN-RUPP PUMPS

www.grpumps.com

Specifications Subject to Change Without Notice

Printed in U.S.A.

Specification Data

SECTION 55, PAGE 1920

APPROXIMATE DIMENSIONS and WEIGHTS

NET WEIGHT: 230 LBS. (104 KG.)*
SHIPPING WEIGHT: 240 LBS. (109 KG.)*
EXPORT CRATE: 7.9 CU. FT. (0,22 CU. M.)
***ADD 8 LBS. (3,6 KG.) W/EACH SPOOL FLANGE**

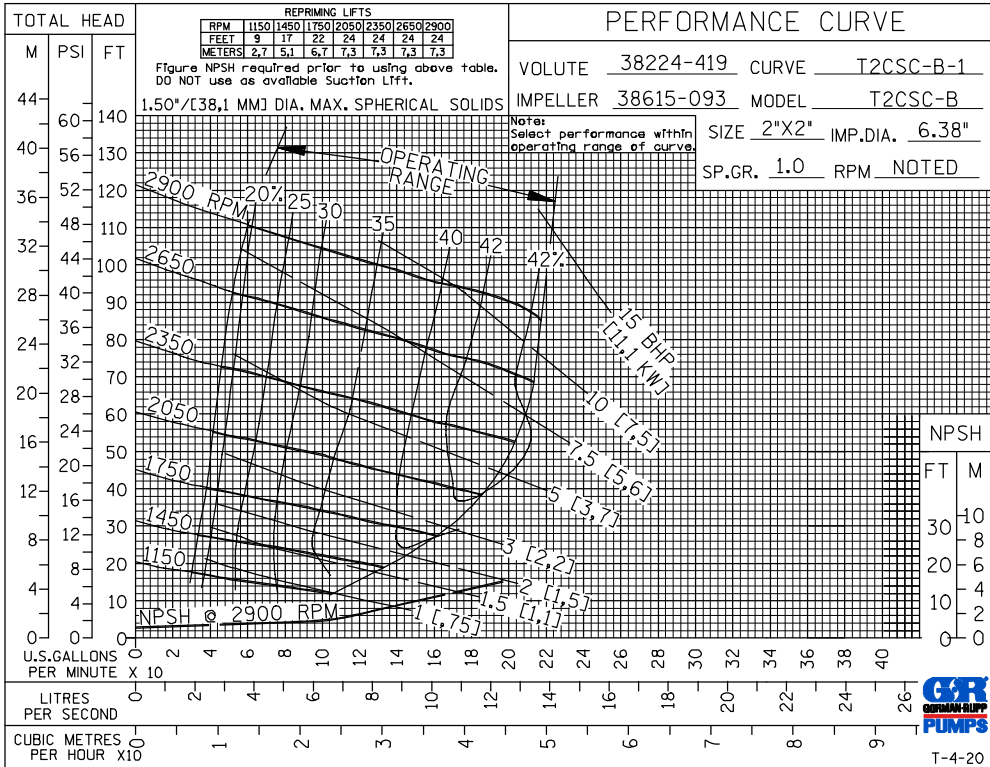
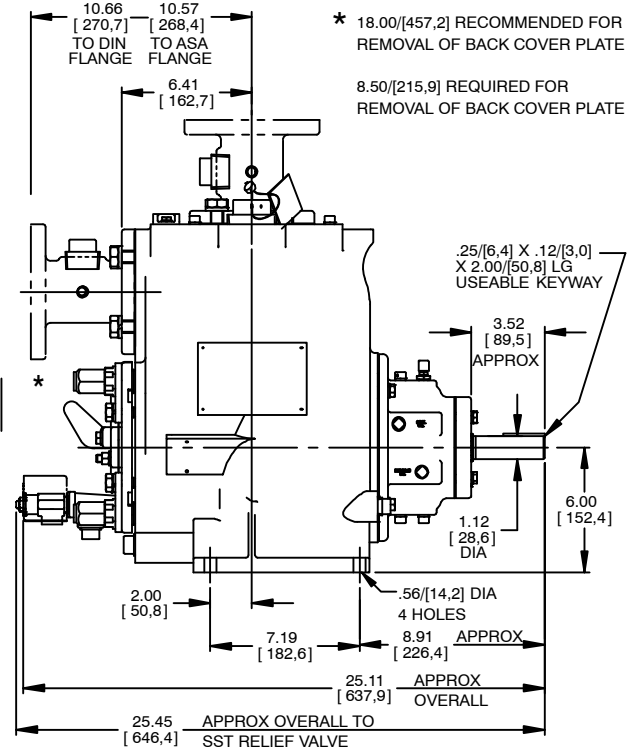
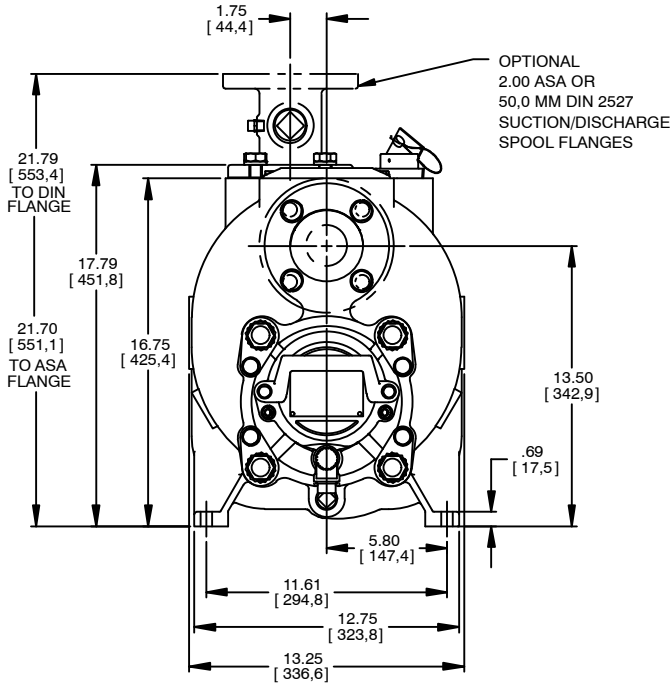

GORMAN-RUPP PUMPS

www.grpumps.com

Specifications Subject to Change Without Notice

Printed in U.S.A.