

## CT22

## PeriFlo<sup>®</sup> ChemTuff<sup>®</sup> Series

### CT22 — a versatile pump for corrosive environments.

Like all Pulsafeeder ChemTuff<sup>®</sup> peristaltic pumps, the CT22 is ideally suited for corrosive chemicals used in water and wastewater treatment, petrochemical and mining industries — including Sodium Hypochlorite, Ferric Chloride, Sodium Hydroxide and Hydrofluosilic Acid.



#### Applications

Metering, batching, transfer and sampling



#### Flow

to 282 gph (1067 lph)



#### Pressure

to 115 psi (7.9 bar)



#### Temperature

Product to 176° F (80° C)  
Ambient to 104° F (40° C)

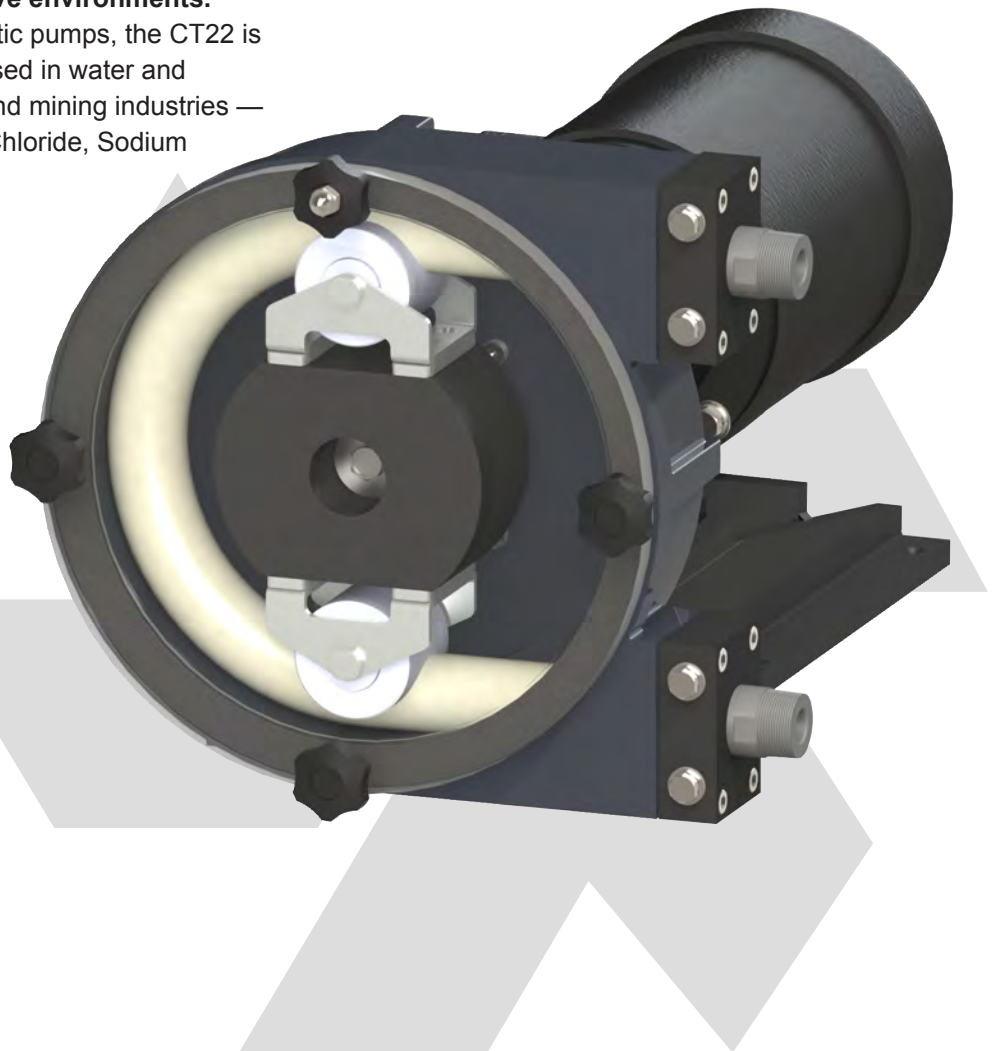

## Peristaltic pumps deliver more than you expect

### Simple operating design

The simple design of a PeriFlo<sup>®</sup> pump results in a pump that is valveless and sealless (creating a gentle pumping action), has reversible rotation, high suction lift, higher solids content handling ability and easy maintenance.

### Variety of Media

Thanks to its gentle pumping action, a peristaltic pump can handle a variety of media where other technologies are unsuccessful, including chemicals, slurries, viscous, abrasive or shear sensitive media such as polymers.

### Pump Longer

The simple design means there are no valves to change and no seals to replace. The hose or tube element is the common wear part and is easy to replace. This means **less** down-time, **less** spare parts inventory and **more** pumping.

## Specifications

Max capacity	0.0549 gal/rev
Max flow rate	282 gph (1067 lph)
Connections	1" MNPT, 1" Camlock
Compressor	Rollers
Max tube pressure	30 psi (2 bar)
Max hose pressure	115 psi (7.9 bar)

## Features & Benefits

- Chemical resistant Halar® coating
- Non-metallic rotor and rollers
- Sealless and Valveless
- Close coupled
- Abrasion resistant
- Dry-run capable
- Self priming to 27 ft.
- Reversible rotation
- Easy maintenance

## Materials of Construction

**Hose:** Natural rubber, Buna, EPDM

**Tube:** Norprene

**Connections:** Male NPT: PVC or stainless steel as standard;  
Optional: Male NPT PVDF or Camlock PVC

**Casing:** Halar® coated aluminum

**Rotor:** Delrin®

**Rollers:** Nylatron®

**Hardware:** Stainless steel

## Drives & Accessories

- Variable speed controls with industry standard I/O's
- Tube/Hose leak detection
- Pulsation dampeners
- Suction accumulators
- Pressure relief valves

## Performance

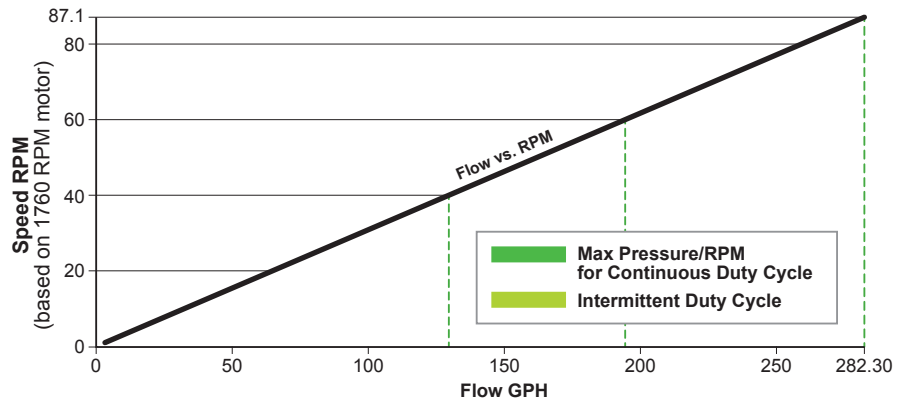

30 PSI / 87.1 RPM	60 PSI / 64.6 RPM	60 PSI / 87.1 RPM
115 PSI / 45.3 RPM	115 PSI / 64.6 RPM	

**Note:** Continuous Duty = run time greater than 2 hours  
Intermittent Duty = run time less than 2 hours with a 1 hour rest period between run times

## Dimensions

Measurements: in [mm]

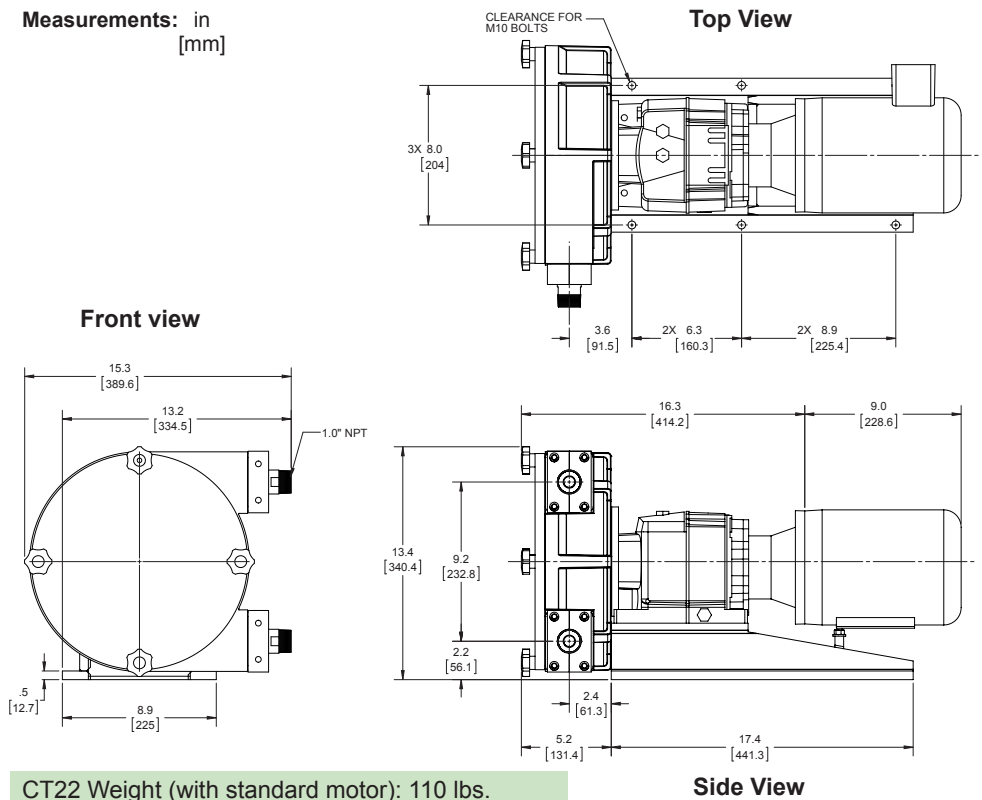

CT22 Weight (with standard motor): 110 lbs.



Pulsafeeder Engineered Products

A Unit of IDEX Corporation

2883 Brighton Henrietta TL Rd • Rochester, NY 14623

Phone: +1 (585) 292-8000 • pulsa@idexcorp.com

[pulsa.com](http://pulsa.com)



**Spec Pulsafeeder.**  
**Get more than you expect.**

© Copyright 2014 Pulsafeeder. All Rights Reserved.  
Delrin® is registered trademark of E.I. DuPont Company.  
Halar® is a registered trademark of Solvay Solexis.  
Nylatron® is a registered trade name of Quadrant EPP.

