

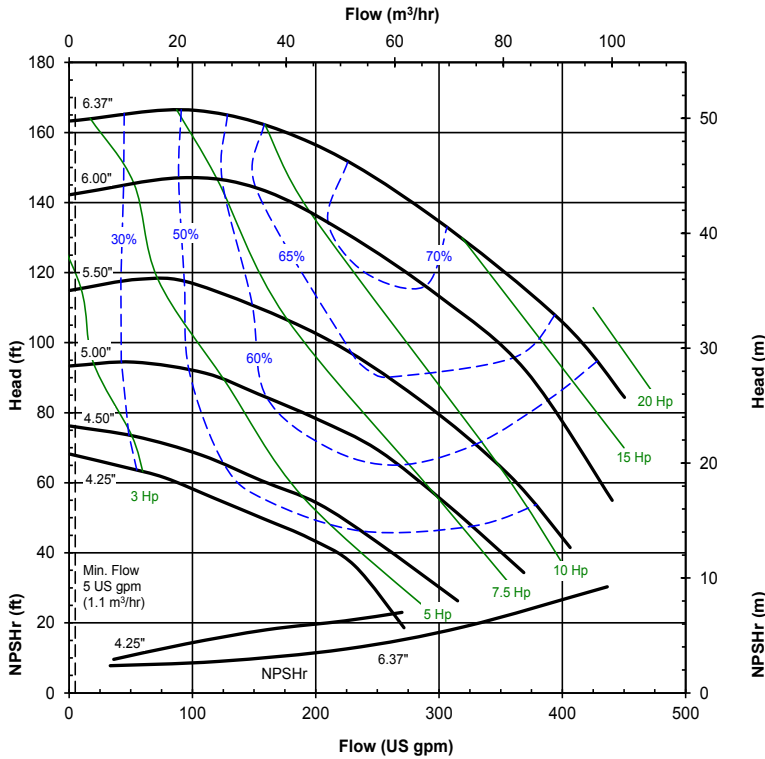

# UC SERIES MODEL UC326 (-- 3X2X6)



## UC326 PERFORMANCE 3500 RPM, 60 Hz



## UC326 PERFORMANCE 2900 RPM, 50 Hz

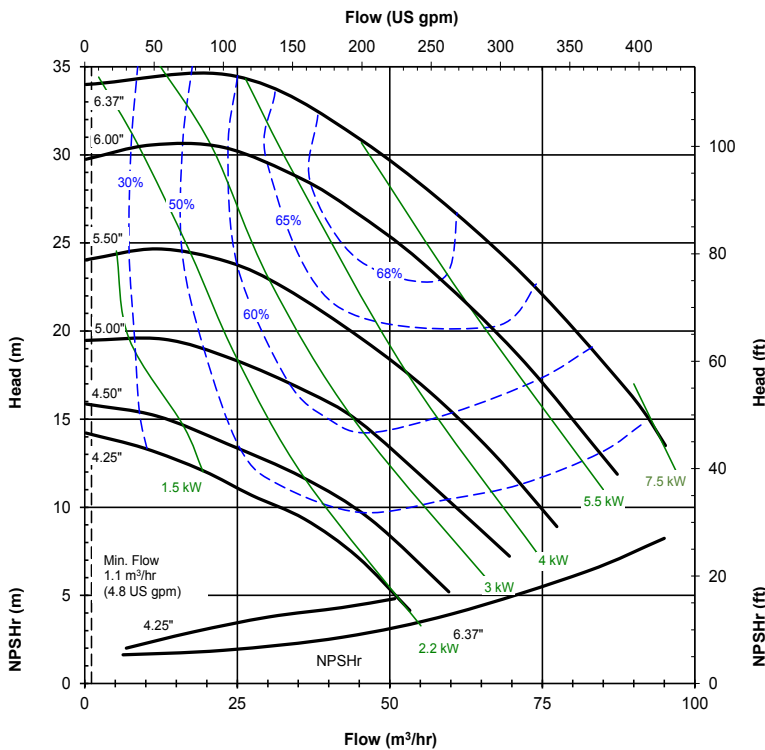

## FEATURES

- Durable, corrosion-resistant Tefzel® lined ductile iron casing
- Casing meets ANSI B73.1m & B73.3 for foot and flange location
- Powerful neodymium magnets for dependable, leak-free operation
- Modified concentric volute reduces radial thrust load
- Rear sealing ring and balance holes balance axial thrust
- Dual bushings provide optimum alignment
- Suction shaft support with integral straightening vanes
- Easy-set measurement free outer drive
- Back pull-out design
- Exclusive vapor protection package to protect outer magnetic drive and motor face from corrosive fumes
- Replaceable 2-piece impeller and drive hub
- Run dry capability with carbon or Dri-Coat SiC bushing
- Casing drain standard
- Specific gravity over 1.8
- Accepts standard NEMA 143-256 or IEC 90-160 motor frames
- ANSI or ISO flange mountable
- ATEX certified models available



## TYPICAL APPLICATIONS

- Paper Mills
- Water treatment
- Plating & metal finishing
- Chemical manufacturing, blending, distribution
- Fume scrubbers
- Pharmaceuticals
- Truck loading/unloading
- Metals manufacturing

## TYPICAL CHEMICALS

- Sodium hydroxide
- Sulfuric acid
- Hydrochloric acid
- Sodium hypochlorite
- Plating solutions
- Corrosive blends
- Solvents
- Wastewater

\*Tefzel® Fluoropolymer Resin is a registered trademark of DuPont

# UC SERIES

Item No.	Description	Construction
1	Casing	Cast ductile iron, DuPont Tefzel® (ETFE) lined
2	Shaft support	Carbon fiber filled ETFE
2A	Front thrust ring	Alpha sintered silicon carbide
3	Impeller	Carbon fiber filled ETFE
3A	Impeller thrust washer	Fluorosint® or alpha sintered silicon carbide
4	Inner drive	Neodymium iron boron magnets encapsulated in ETFE
4A	Bushing	Alpha sintered silicon carbide, Dri-Coat silicon carbide, or carbon
4B	Bushing spacer	PTFE
4C	Rear sealing ring	GF molybdenum disulfide-filled PTFE
5	Shaft	Alpha sintered silicon carbide
6	Barrier	Molded carbon fiber filled ETFE liner with woven glass reinforced vinyl ester external shell
6A	Barrier thrust ring	High purity alumina ceramic
7	Clamp ring	Steel
8	Outer drive magnet	Nickel-plated neodymium iron boron magnets/steel
9	Motor adapter	Ductile iron
10	O-ring	FKM, EPDM, Kalrez®, Simriz®, or Aflas®
11	Vapor Protection O-Rings	Buna

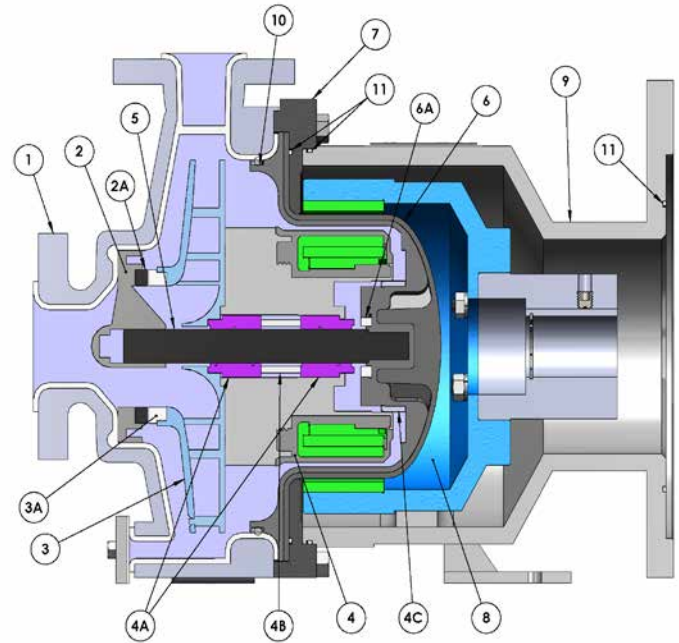

Kalrez® is a registered trademark of DuPont Performance Elastomers  
 Simriz® Perfluoroelastomer is a registered trademark of Simrit® division of Freudenberg-NOK.  
 Aflas® is a trademark of the Asahi Glass Co., Ltd.  
 Fluorosint® is a registered trademark of Quadrant DSM Engineering Plastic Products.

## SPECIFICATIONS

HP (kW)	Impeller Diameter	Suction in (cm)	Discharge in (cm)	Max. Flow 3500 rpm		Max. Head 3500 rpm		Max. Working Pressure psi (Bar)	Max. Viscosity cP	Max. Specific Gravity	Max. Temp. °F (°C)
	in (cm)			gpm	m <sup>3</sup> /hr	ft.	m				
3 - 20 (1.1 - 15.0)	4-1/4 - 6 3/8 (10.2 - 16.2)	3 (7.62)	2 (5.01)	450	102	166.7	50.8	175 (12)	200	1.8	250 (121)

Note: Impeller trims available every 1/8" (.32 cm) between the smallest and largest diameters.

## DIMENSIONS

### SIDE VIEW

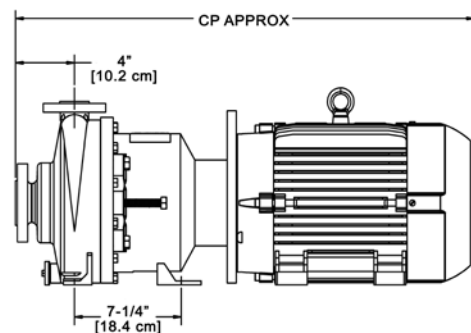

ANSI 150# & ISO/DIN PN20 flanges are in compliance with bolting dimensions only.

Motor Frames	CP (approx.)	
	(in)	(cm)
<b>NEMA</b>		
143-145TC	23-17/32	59.8
182/184TC	28-3/32	71.3
213/215TC	31-5/32	79.1
254/256TC	34-9/32	81.7
<b>IEC</b>		
90	23-19/32	59.9
100/112	25-1/32	63.6
132	31-3/32	79
160	34-27/32	88.5

### FRONT VIEW

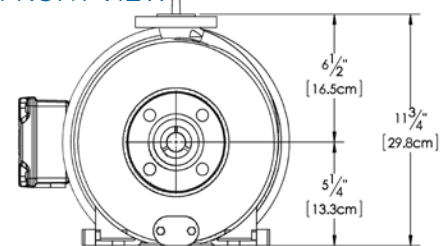

### BOTTOM VIEW

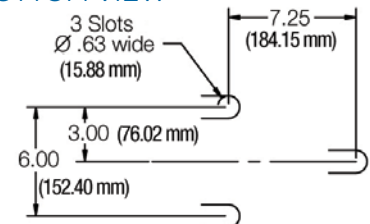

finishthompson.com

### FINISH THOMPSON INC. - UNITED STATES

921 Greengarden Road | Erie, PA 16501  
 800.934.9384 | ph 814.455.4478 | fx 814.455.8518  
 email fti@finishthompson.com

### FINISH THOMPSON INC. - GERMANY

Otto-Hahn-Strasse 16 | Maintal, D-63477 Germany  
 49 (0)6181-90878-0 | fx 49 (0)6181-90878-18  
 email fti@finishthompson.com