

# LOW-NOX BURNER RETROFIT CHALLENGE

By

***Craig Lieb***

*Applications Engineer*

*Zeeco, Inc.*

*Rutland, UK*

***Ryan Roberts***

*Project Engineering Manager*

*Zeeco, Inc.*

*Broken Arrow, OK, U.S.A.*

Ryan Roberts has more than 20 years of combined combustion experience for the process burner industry. His experience includes 5 years of working as a Project Engineer at Zeeco on thermal oxidizer, flare, and burner projects before moving into the process burner group. Ryan served as a Project Engineer as well as a Project Manager for the first 19 years of his career at Zeeco, and has experience in a wide range of burner projects for both the process and power industries. He has had the good fortune to travel extensively with Zeeco for startup and commissioning of different burner projects around the world. Ryan has been a member of the Zeeco team since 1995 and currently serves as the Project Engineering Manager for the process burner group. He graduated from the University of Oklahoma's Mechanical Engineering Program in 1995.

Presented at the

2016 Spring Meeting and 12th Global Congress on Process Safety  
Houston, Texas -- April 10-14, 2016 (April 12, 2016)

## Introduction

As increasingly stringent NOx requirements are implemented around the world, end users with fired heaters and industrial boilers are forced to update existing fired equipment to meet regulations. Both new applications and retrofits projects may need Ultra-Low NOx or Next Generation Low NOx Burners to meet the ever-tightening emissions requirements. Recently, Zeeco accepted a retrofit challenge to replace 34 conventional burners at a European refinery with a capacity of 11.5 million tonnes per year. The project objectives were to significantly reduce NOx production, increase combustion efficiency, and eliminate flame impingement on the heater process tubing. Zeeco's GLSF Min-Emissions Ultra-Low NOx Burner was the selected equipment to achieve these goals.

## Background

The existing raw gas burners installed on the client's forced draft, pre-heated air, crude heater were proving troublesome. The existing burners were producing NOx values well above 200 mg/Nm<sup>2</sup> [100 ppmv]; the combustion in the firebox was poorly distributed across the burners; and in several places, the burner flames were long enough to impinge on the short heater roof tubes, causing process tube coking. To eliminate these issues, the client decided to retrofit the crude heater with Ultra-Low NOx burners. Zeeco was selected to provide 34 GLSF-8 Round Flame, Min-Emissions Ultra-Low NOx Burners. The heater is a twin-celled cabin heater with a sloped roof leading to a common, central, convection section. There is one row of 17 burners installed in each heater cell. A rendering of the cross-sectional view of the heater can be seen in Figure 1 below along with the original heater drawing for reference.

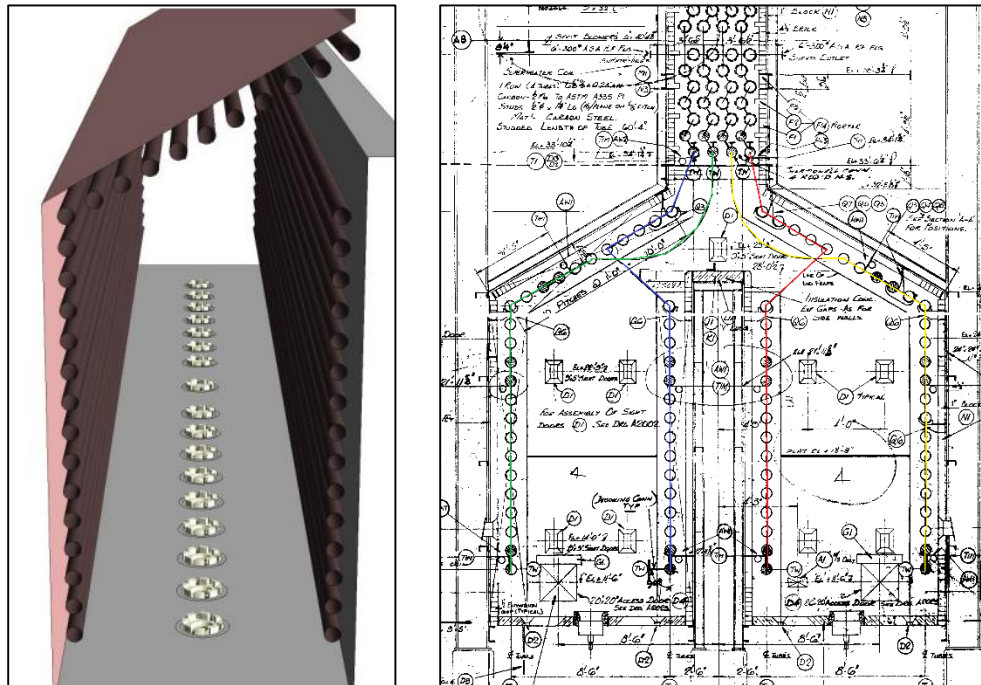

Figure 1: Heater Geometry

## Project Phases

This project was completed in three main phases. The first phase included the design and drafting of the burners, and the completion of two geometry models for Computational Fluid Dynamics (CFD) simulation. The two CFD models included the existing forced draft, preheated air ducting system, and half of the heater firebox geometry with the row of 17 burners. Phase two included the completion of a combustion test performed at Zeeco's combustion testing facility in Tulsa, Oklahoma. The test was conducted with two GLSF-8 Min-Emissions burners installed in one of Zeeco's cabin-style heaters. Phase three included the installation and commissioning of the burners on site, as well as site acceptance emissions measurements.

### ***Phase One – Burner Design and CFD Modeling***

The geometry of the existing combustion air ducting system required a custom burner design to match the existing combustion air inlet and the heater mounting dimensions. The customized burner design varied in several physical aspects from Zeeco's standard burner design. The final burner design geometry can be seen below in Figure 2.

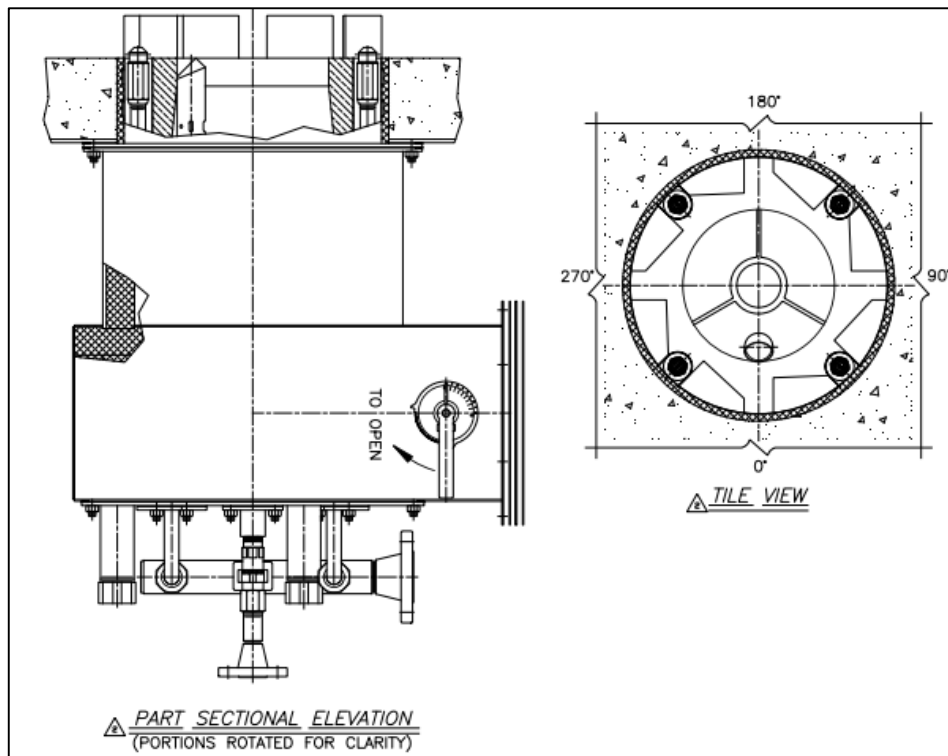

Figure 2: Final Burner Design

In order to examine and then improve the air flow distribution in the existing forced draft ducting system, Zeeco modeled the full furnace ducting geometry. Several iterations were simulated in order to design and locate specific baffle plates and turning vanes. Examining the original geometry showed the air flow distribution to each burner was uneven, varying by as much as +13% and -30% mass flow [kg/hr] across the 34 burners. This was deemed unacceptable for the successful operation of the new Ultra-Low NO<sub>x</sub> burners. New turning vanes and baffle plates were implemented into the model geometry to improve the airflow distribution. At the conclusion of the iterations, the designed airflow to each burner improved to within the desired +/- 3% [kg/hr]. Zeeco created and supplied the client with a detailed CFD report showing the locations and dimensions of the designed turning vanes and baffles so the ducting modifications could be performed during shutdown. A snapshot comparison of the velocity profile through the ducting before and after the implementation of new turning vanes and baffles is shown in Figures 3 & 4.

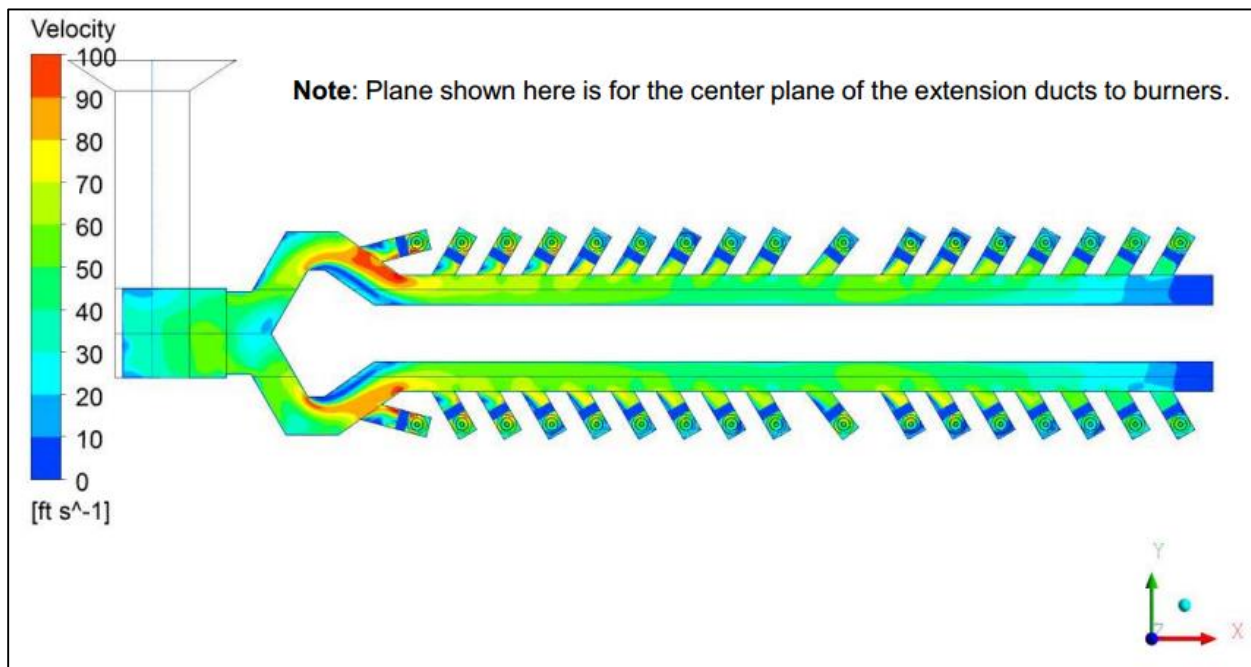

Figure 3: Combustion Air Velocity Profile – Existing Geometry

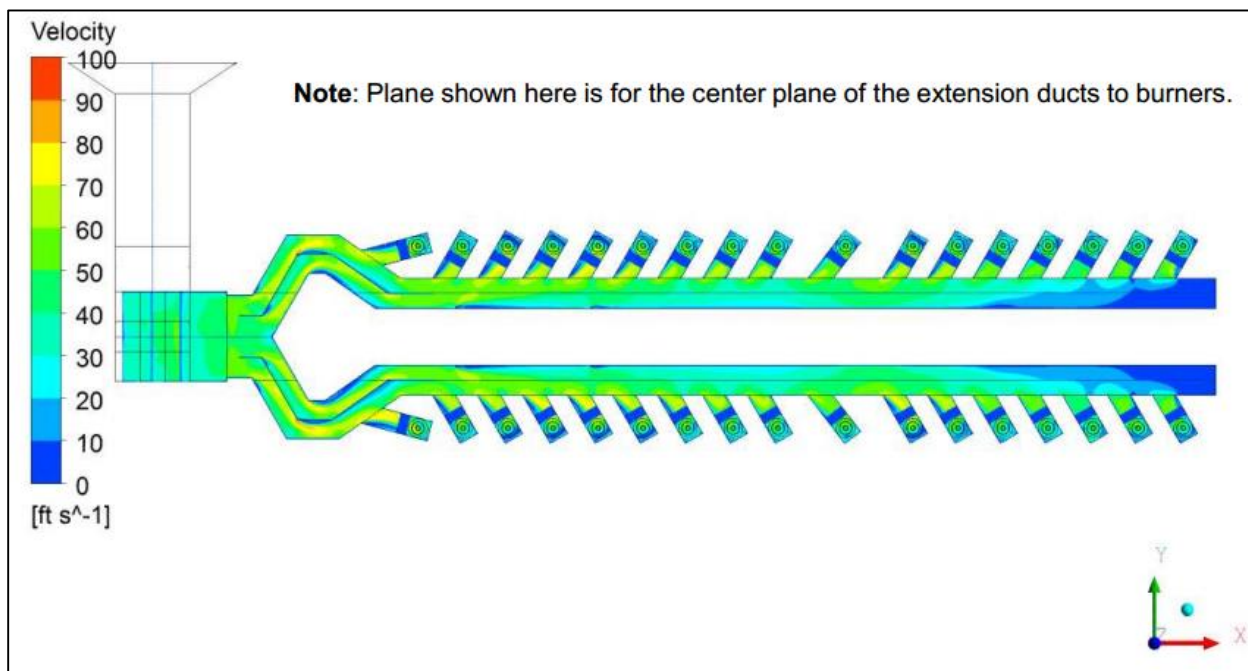

Figure 4: Combustion Air Velocity Profile – Modified Geometry

A CFD of the heater firebox was modeled to ensure proper flame profiles and heat distribution to the process tubes. The model included half of the heater geometry and 17 ZEECO® burners due to heater symmetry. The flue gas patterns and flame dimensions were evaluated and were deemed acceptable by both Zeeco and the client. The predicted flame length as based on 2150 ppm CO (dry) iso-surface was 8.19 feet.

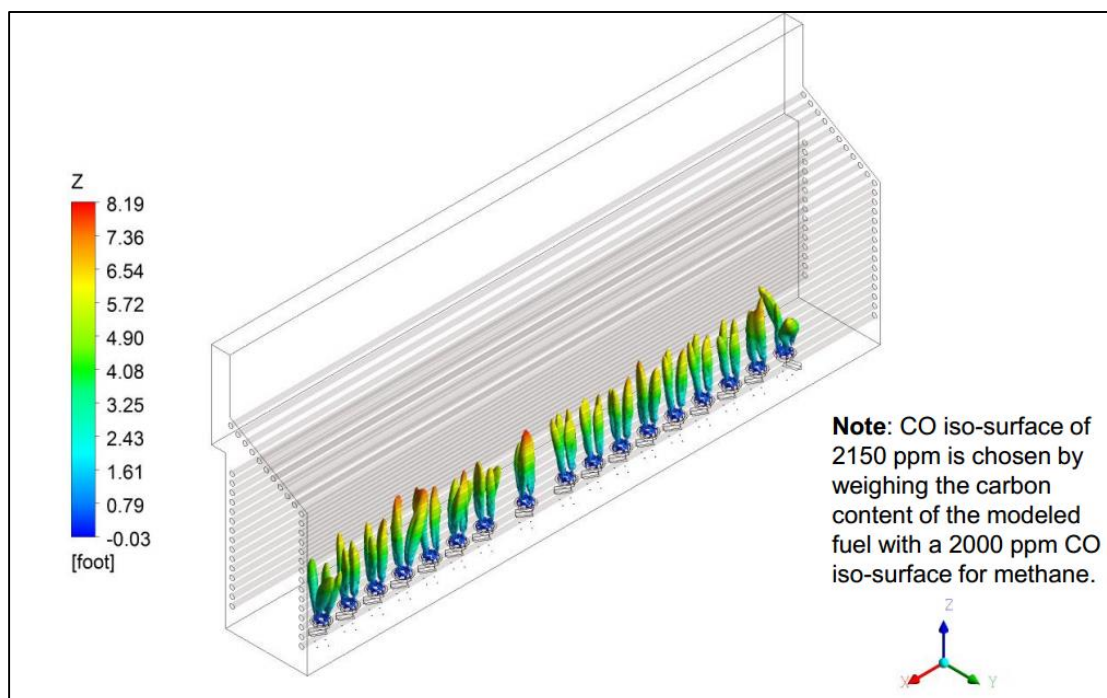

Figure 5: CFD Flame Profiles

All burner design features and CFD geometries and results were approved by the client's engineers.

***Phase Two – Combustion Testing***

Zeeco's test facility engineers performed a witnessed test for members of the client's engineering team. The goal of the combustion test was to confirm predicted emissions values when firing the fuel cases specified, and to confirm the flame stability and flame dimensions. The challenges included modifying the Zeeco test furnace to match the burner spacing, modifying the heater internal dimensions and insulation to match the furnace temperature of the site operation, and simulating the required fuel compositions. Twenty seven test points were performed to confirm the required burner performance. Test results were as follows:

**Table 1: Burner Test Fuels**  
**BURNER TEST FUELS**

<b>GAS</b>						
<b>FUELS</b>	<b>LHV</b>	<b>SP.GR.</b>	<b>FUEL B</b>	<b>FUEL E</b>	<b>FUEL F</b>	<b>FUEL G</b>
NATURAL GAS	937.4	0.5982	60	46	32	100
HYDROGEN	273.8	0.0696	26	24	48	
PROPANE	2314.9	1.5226	14	30	20	
<b>TOTAL</b>			100	100	100	100
<b>LHV (BTU/SCF)</b>			957.7	1191.4	894.4	937.4
<b>SP. GR.</b>			0.590	0.749	0.529	0.598
<b>MW</b>			17.09	21.68	15.33	17.33

Test fuels were blended upstream of the burner to accurately match the fuel gases being fired on site. The chosen test fuels were then fired in a range of conditions to simulate the variety of site operation conditions defined by the client's engineers. The fuel gas pressure, combustion air pressure and temperature, and furnace flue gas oxygen percentage were all varied according to agreed upon testing procedures so the burner performance could be confirmed. The NOx emissions burner test figures are shown below for the maximum firing rate of each dedicated test fuel.

**Table 2: Test Results at Maximum Firing Rates**

Fuel Case	Heat Release [MMBTU/HR]	Measured Furnace Temperature [F]	Measured O2 %	Measured NOx [ppmv]	Corrected NOx [ppmv] @ 3% O2 and 1790F
Fuel B	6.98	1776	3.0	27.0	27.5
Fuel E	6.98	1759	2.9	27.4	27.9
Fuel F	6.98	1740	3.0	30.4	31.6
Note: A single Fuel G test point was tested to prove flame stability on N.G.					

The testing results, along with the results from other test points, proved the GLSF-8 Round Flame Min Emissions Burner would successfully achieve the required emissions levels while maintaining a desirable flame profile in the furnace.

### ***Phase Three – Installation & Site Acceptance Testing***

Upon delivery of the equipment, Zeeco performed several site supervision trips to ensure proper installation of the burners. All mechanical dimensions of the burner design proved to match the existing heater cutout and combustion air ducting mounting. The burners were successfully started up in June, 2015 and the site acceptance test was performed one month later in July, 2015. A review of the heater revealed that the heater was operating at a higher excess air rate than the designed 15%. In fact, the heater was operating around 25% to 30% excess air, which correlates to 5.25% to 6.3% oxygen in the flue gas. Additionally, the gaps around the process tube penetrations were not sealed, allowing for tramp air to enter the heater. Tramp air is defined as any uncontrolled air entering the firebox through any locations outside of the burner combustion air stream. Tramp air has been proven to increase the emissions produced by combustion due to the uncontrolled addition of air into the combustion chamber. Zeeco recommended that the client seal these tramp air infiltration points.

During the site acceptance test, emissions were measured with a Testo 350 analyzer at a sample point located just below the common convection section. Emissions measured were observed to be at an acceptable level and were under the 50 ppmv [100 mg/Nm<sup>3</sup>] requirement set by the end user's local legislation. The values measured over the span of about half an hour ranged from 42 ppmv to 45 ppmv [86 to 92 mg/Nm<sup>3</sup>]. Both the client and Zeeco agreed that when the tramp air locations were eliminated and the oxygen level in the heater decreased to the designed level of 15%, the NOx emissions would drop to the levels shown in the combustion testing at Zeeco's facility.

### **Project Review**

The three phases of the project required time and careful technical engineering design to achieve the successful results reported by the end user since start up. The scheduling of the project needed to be maintained at a constant pace of progression in order to engineer the

customized burner design, generate the CFD results and reports, set up and execute the combustion test, manufacture and deliver the equipment, and finally, execute a successful install and start up. Overall, the project was completed in 44 weeks from start to finish. The equipment was delivered as scheduled, before a scheduled major site turnaround.