



For more information scan the code.



Sheet Metal VLS

The Sheet Metal Vertical Lift System (VLS) is an automated storage and retrieval system (AS/AR) that utilizes an elevator to climb the front of the tower to deposit and retrieve cartridges weighing up to 5,000 lbs and deliver them directly to the ground level for further processing, increasing material storage and improving production flow. Further, integrating storage and processing can eliminate costly retrieval steps, increase production machinery uptime, and reduce associated labour.

- Eliminates the need for forklifts during standard operation. (operator, spotter, forklift)
- Reduce material changeover time by as much as 75%.
- Utilizes overhead space for maximum storage density.
- Prevent material damage.
- Ergonomic design increases workplace safety and prevents injuries.
- Improved productivity with more efficient SKU picking.

Safe Handling • Easy Access • Maximum Storage • Fast Retrieval • Small Footprint

Toll Free: 800.210.0141 www.storevertical.com

Sheet Metal VLS



60" x 120" x 3.5" Capacity ¹				
Models	Height	Width ²	Depth ²	Pallets
VLS510-B14-3.5	13' 0"	15' 8"	15' 9"	14
VLS510-B19-3.5	15' 9"	15' 8"	15' 9"	19
VLS510-B14M9-3.5	18' 10"	15' 8"	15' 9"	23
VLS510-B14M13-3.5	20' 10"	15' 8"	15' 9"	27
VLS510-B19M9-3.5	21' 8"	15' 8"	15' 9"	28
VLS510-B19M13-3.5	23' 8"	15' 8"	15' 9"	32

60" x 120" x 5" Capacity ¹				
Models	Height	Width ²	Depth ²	Pallets
VLS510-B12-5	13' 5"	15' 8"	15' 9"	12
VLS510-B16-5	16' 2"	15' 8"	15' 9"	16
VLS510-B12M8-5	19' 5"	15' 8"	15' 9"	20
VLS510-B12M11-5	21' 6"	15' 8"	15' 9"	23
VLS510-B16M8-5	22' 2"	15' 8"	15' 9"	24
VLS510-B16M11-5	24' 3"	15' 8"	15' 9"	27

1. Additional Configurations are available.

2. Measurements with fully enclosed perimeter fencing. Depending on accessibility, the actual measurements may be less.

VLS Cart Loading Instructions



1. Place an empty pallet on the loading table/cart. If required, direct the pallet and cart in the necessary direction to the desired loading position.

2. Load the flat material onto the loading table/cart. The material will rest approx. 5" above the pallet on protruding fingers properly spaced to allow access via fork truck.

3. Move the cart to the home position. The elevator will then lift the pallet 5" until the material is resting on the pallet and then continue to lift both the pallet and material to put away.

VLS Access Points

With access from all 4 sides, up to 2 carts per lift available, and 3 cart styles to choose from, the options for loading and feeding production machines is limitless.

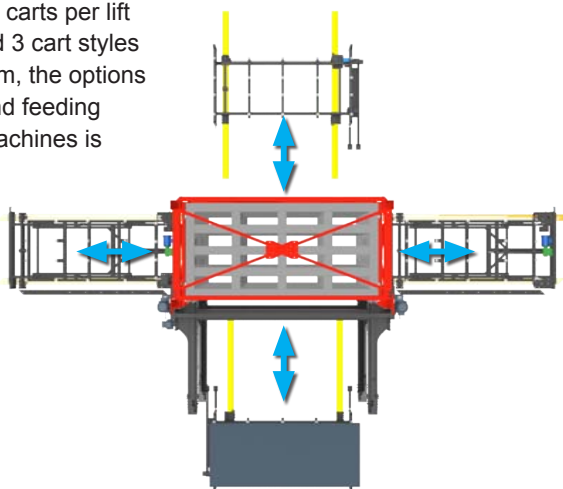

VLS At A Glance

Controls: Automatic controls featuring pallet selection

Emergency Stops: Located left and right of the tower

Overload Sensing: Lift returns to the home position when activated

Access Restriction: Fencing around the perimeter and light curtains prevent access during operation

Braking System: Features a process brake and a redundant brake engaged with the safety system

Cartridge Safety: Each pallet is individually locked in place until released by the elevator

Motors: 2 x SEW KAF87 5hp motors & 1 x SEW KAF47 3/4hp

Safety System: Designed to SIL3 / CAT4 / PL e

Safe Handling • Easy Access • Maximum Storage • Fast Retrieval • Small Footprint

Toll Free: 800.210.0141 www.storevertical.com