

INSTRUCTION MANUAL

PORTABLE MAGNETIC DRILLING MACHINE

Read this manual carefully before operating your Nitto Kohki Portable Magnetic Drilling Machine. Keep this manual with your machine. All users of the Nitto Kohki Portable Magnetic Drilling Machine must read this manual.

ATRA ACE Model LO-3550 Professional Tool

For One-Touch Type Annular Cutter Only
(Side-Lock Type Annular Cutter cannot be used.)

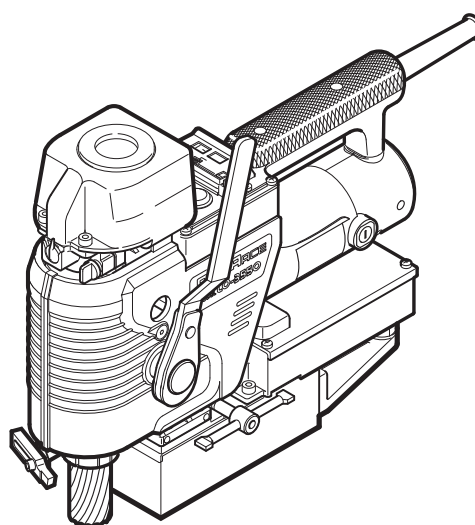

Specifications

Model		LO-3550
Drill Motor	Power Supply (Single Phase)	220-240 V ~ 50/60 Hz
	Rated Power Consumption	800 W
	Rated Current	3.3 A
	No-load Speed	950 min
Magnet Power Consumption		35 W
Drilling Capability	JETBROACH One-touch type	Hole diameter: 12 mm to 35 mm dia. Plate thickness: MAX. 50 mm
Max Magnetic Force		5500 N
Magnet Size		65 mm x 145 mm
Weight		8.7 kg (Cord and Sub handle are not included.)

The specifications and configurations contained in this document are subject to change without prior notice due to improvements we are making day in, day out.



Manufactured by :

NITTO KOHKI Co., Ltd.
2-9-4, Nakaikegami, Ohta-ku,
Tokyo, 146-8555, Japan
TEL : (81)-3-3755-1111
FAX : (81)-3-3753-8791
E-mail : overseas@nitto-kohki.co.jp
URL : www.nitto-kohki.co.jp

Keep the manual handy – so you can use it whenever necessary.

Original Instruction

Thank you very much for your purchase of this **Nitto Kohki product**. Before using your machine, please read this manual carefully so that you may use it properly to get the most out of it.

Please keep the manual handy - so you can use it whenever necessary.

- **English** :Please ask your dealer or distributor for instruction manual in local language(s).
- **German** :Bitte fragen Sie Ihren Händler nach eine Betriebsanleitung in Landessprache.
- **French** :S'il vous plait, veuillez demandez á votre fournisseur de manuel instruction en langue locale.
- **Spanish** :Por favor, contacte con su distribuidor para el manual de instrucciones en español.
- **Portuguese** :Por favor pessa ao seo agente ou distribuidor o manual de instrucoes ih linguagen local.
- **Italian** :Per Manuale Istruzioni in lingua locale Vi preghiamo di rivolgervi al rivenditore o distributore.
- **Dutch** :Vraag uw handelaar om een nederladstalige gebruiksaanwijzing.
- **Swedish** :Be er lokala Åtreförsäljare eller distributör om manualer pá svenska.
- **Danish** :Venligst henvend Dem til den danske distributør for instructions manualer.
- **Polish** :Prosze pytac swojego dealera lub dystrybutora o instrukcje obslugi w jezyku localnym.
- **中文** : 請向當地供應商或經銷商詢問中文使用說明書

CONTENTS

	page
GENERAL SAFETY RULES	2
GENERAL POWER TOOL SAFETY WARNINGS	3
POWER TOOL SAFETY	5
ABOUT YOUR NITTO PORTABLE MAGNETIC DRILLING MACHINE	5
1. APPLICATION	8
2. RECEIVING INSPECTION	8
3. PART NAMES	9
4. FUNCTIONS OF ELECTRONIC CONTROL	10
5. MACHINE SETUP	10
6. MACHINE OPERATION	14
7. TROUBLESHOOTING	17
8. MAINTENANCE/SERVICE	18
9. OPTIONAL PARTS	19
10. ATRA ACE LO-3550 MOTOR ASSEMBLY AND PARTS LIST	21
11. ORDERING PARTS	22

PICTOGRAM



Warning: It might be dangerous to operate the machine if the instructions supplied are not followed.



Do not allow the main body or the power source to get wet as it will cause electric shock and leakage.



Using this machine improperly could result in serious injury. Read the instruction manual before use.



Always wear suitable eye protection.



Always wear suitable hearing protection.



Always wear respiratory protective equipment (PPE).

- Sound pressure level(LpA)= 85dB(A) according to EN 60745.
- Sound Power Level(LwA)= 96dB(A) according to EN 60745.
- Uncertainty K=1.2 dB(A)

Vibration total values (triax vector sum) determined according to EN 60745:

- Vibration emission value ah=32m/s²
- Uncertainty K=2.2m/s²

● Operating Temperature : 5°C ~ 40°C

● Operating Humidity : Maximum 90% at 25°C

● Altitude : 1000m Max.

The following Safety notations are used throughout the manual to highlight safety precautions for the user and for the machine.

DANGER:	Indicates an imminently hazardous situation which, if not avoided by following the instructions given, will result in death or serious injury.
WARNING:	Indicates a potentially hazardous situation which, if not avoided by following the instructions given, could result in death or serious injury.
CAUTION:	Indicates a potentially hazardous situation which, if not avoided by following the instructions given, could result in injury or material damage.

Caution: Important precautions for machine or tool setup, operation and maintenance.

GENERAL SAFETY RULES

WARNING

TO OPERATORS

Always Wear Proper Clothing

- Do not wear loose clothing. Loose clothing can become caught in the drilling machine. This could cause severe injuries. Be careful that loose clothing does not come into contact with the machine.
- Wear non-skid footwear. If you lose your footing, you could contact moving portions of the machine. This could cause severe injuries. Always wear non-skid footwear and remain balanced when using the drilling machine.
- Be careful of long hair. Wear a hat or a hair net to contain long hair. Long hair can become caught in the drilling machine. This will cause severe injuries. Be careful that long hair does not come into contact with the drilling machine.

Always Wear Suitable Eye Protection

- Always wear suitable eye protection. The operation of your drilling machine will cause flying chips and particles. These will cause severe eye injuries. You must always wear suitable eye protection.
- Not all glasses are suitable eye protection. Wear only suitable eye protection that comply with ANSI standards. Not all of the lenses are shock resistant. Ordinary glasses will not provide sufficient eye protection. Glasses only for visual correction are not appropriate to be used as safety glasses.

Always Wear Suitable Hearing Protection

- Always wear suitable hearing protection. The operation of your drilling machine will cause big sound occurs. These will cause severe hearing loss injuries. You must always wear suitable hearing protection.

Always Wear respiratory protective equipment (PPE)

- Always Wear respiratory protective equipment (PPE) when working in an environment where dust particles are generated in operation.

Maintain Good Posture

- Always wear non-skid footwear and maintain good posture. Do not use the drilling machine when you are tired. Fatigue or loss of balance could cause you to lose control of the machine. This could cause severe injuries. Always stay balanced. Always keep good posture. Stop using the machine if you are tired.

Never Touch the Cutting Tip

- Never touch the moving or cutting tip. Contact with the moving tip will cause severe injuries. Always keep all parts of your body away from the cutting tip.

Always keep your hand and clothing away from the cutting tip.

ABOUT THE WORK AREA

Keep Work Area Clean

- Always keep your work area clean. Cluttered work areas cause accidents. Always keep clear of other objects.
- Never use the magnetic drilling machine when it is wet. Always use the drilling machine in a dry area. Do not use the drilling machine in the rain. If you use the machine when it is wet you can get electric shock. If you use the machine in the rain you can get an electric shock.
- Always use the drilling machine in a well-lighted area. Do not use the drilling machine in the dark.
- Avoid all flammable materials. Use of the drilling machine may cause a spark that could ignite a fire or an explosion. Never use the machine near any flammable material.
- Keep away from children. Always keep the drilling machine away from children. Do not operate drilling machine when children are present.

BEFORE OPERATION

Make sure that all parts are free from damage

- Make sure that the drilling machine is in good operating condition. Operation of a damaged machine could result in severe injuries. If there is any damage to the machine, do not use the machine. If there is any damage to the machine, take it to an authorized Nitto dealer for repair.
- Do not attempt service or repair of the drilling machine. All service or repair should be done by an authorized Nitto dealer.
When a failure is observed with the switch, request for repair to the sales agent where the product was purchased or your nearest authorized Nitto dealer. Do not use the machine that cannot be started or stopped by the start switch.
When a damage is observed with the power cord, request for repair to the sales agent where the product was purchased or your nearest authorized Nitto dealer.

Secure Your Work

- Always secure your work piece. Improperly mounted work can become loose. This can cause severe injuries. Always secure all work.
- Always use a vice or a clamp. Do not attempt to hold any work piece with your hand. Attempting to hold a work piece with your hand may cause severe injuries. Always use a vice or clamp to hold the work piece.

- Always secure your drilling machine. Improperly mounted drilling machine can come loose. This can cause severe injuries. Always secure the drilling machine.

Avoid Clutter

- Always stay clear of other objects. Cluttered work areas cause accidents. Always keep a clean work area and stay away from other objects.

Always Remove Spanner Wrenches and Adjustment Tools

- Always remove spanner wrenches and adjustment tools after adjustments have been made to the drilling machine. Always remove all adjustment tools before using the drilling machine.

Always Use a Cutter that is Appropriate for Your Work

- Always use a Cutter that is appropriate for your work. Avoid heavy-duty work that is the beyond the capacity of your drilling machine. If the work exceeds the capacity of your drilling machine, this can cause accidents and severe injuries. Always use the drilling machine in accordance with its performance specifications.

SAFE HANDLING

- Never leave the magnetic drilling machine unattended while it is running. When the machine is unattended, disconnect the power source. Do not leave the work area until the machine comes to a complete stop. Operating the machine while it is unattended can case accidents that may result in severe injuries.

HOW TO STORE YOUR MAGNETIC DRILLING MACHINE

- Always store the machine in a dry area.
- Always keep the machine out of the reach of children.

HOW TO CARRY YOUR MAGNETIC DRILLING MACHINE

- Disconnect the power and turn off the machine whenever you carry the machine.
- Pay attention when carrying the machine. Keep your hands away from the start switch when carrying the machine. Do not hold parts other than the handle to carry the machine.

MAINTENANCE

Do not take apart or modify your magnetic drilling machine.

- Do not attempt to disassemble or modify your magnetic drilling machine.
- Do not modify your magnetic drilling machine.

Modifications can cause accident and severe injuries.

- All service and repairs must be performed by an authorized Nitto dealer. Any attempt to service or repair the machine yourself may result in an accident and severe injuries.

Check all Parts for Damage.

- Always inspect the magnetic drilling machine before use.
- Always check that the pilot pin and cutter are in good condition. Use of the machine with worn pilot pins or worn cutter can cause accidents and severe injuries.
- Inspect all cutter before you put them on the magnetic drilling machine.
- Do not operate the magnetic drilling machine with a damaged or worn cutter. Do not operate the machine with a damaged or worn pilot pin. Do not operate the machine with any damaged accessory. Operating the machine with any damaged part or accessory can cause accidents and severe injuries. If there is any damage to the magnetic drilling machine do not operate the machine. Take it to an authorized Nitto Dealer for repair.
- Always have the magnetic drilling machine repaired at an authorized Nitto dealer. Always take the magnetic drilling machine to an authorized Nitto dealer for service, repair and replacement parts. If you cannot locate an authorized Nitto dealer near you, please contact your sales representative.
- Always use Nitto genuine parts. The use of improper or non-Nitto parts can cause accidents and severe injuries. Never use unauthorized parts. To obtain genuine Nitto parts, contact your sales agent.
- Do not remove any nameplate from your magnetic drilling machine. Do not remove any labels from your magnetic drilling machine. If any label or nameplate is damaged contact your sales agent for a replacement.
- When a damage is observed with the power cord, request for replacement at your nearest authorized Nitto dealer to avoid accidents.

GENERAL POWER TOOL SAFETY WARNINGS

 **WARNING**

- **Read all safety warnings and all instructions.** Failure to follow the warnings and instructions may result in electric shock, fire and/or serious injury.
- Save all warnings and instructions for future reference.
- The term "power tool" in the warnings refers to your

mains-operated power tool.

<Work area safety>

- **Keep work area clean and well lit.** Cluttered or dark areas invite accidents.
- **Do not operate power tools in explosive atmospheres, such as in the presence of flammable liquids, gases or dust.** Power tools create sparks which may ignite the dust or fumes.
- **Keep children and bystanders away while operating a power tool.** Distractions can cause you to lose control.

<Electric safety>

- **Power tool plugs must match the outlet. Never modify the plug in any way. Do not use any adapter plugs with earthed (grounded) power tools.** Unmodified plugs and matching outlets will reduce risk of electric shock.
- **Avoid body contact with earthed or grounded surfaces, such as pipes, radiators, ranges and refrigerators.** There is an increased risk of electric shock if your body is earthed or grounded.
- **Do not expose power tools to rain or wet conditions.** Water entering a power tool will increase the risk of electric shock.
- **Do not abuse the cord. Never use the cord for carrying, pulling or unplugging the power tool. Keep cord away from heat, oil, sharp edges or moving parts.** Damaged or entangled cords increase the risk of electric shock.
- **When operating a power tool outdoors, use an extension cord suitable for outdoor use.** Use of a cord suitable for outdoor use reduces the risk of electric shock.
- **If operating a power tool in a damp location is unavoidable, use a residual current device (RCD) protected supply.** Use of an RCD reduces the risk of electric shock.

<Personal safety>

- **Stay alert, watch what you are doing and use common sense when operating a power tool. Do not use a power tool while you are tired or under the influence of drugs, alcohol or medication.** A moment of inattention while operating power tools may result in serious personal injury.
- **Use personal protective equipment. Always wear eye protection.** Protective equipment such as dust mask, non-skid safety shoes, hard hat, or hearing protection used for appropriate conditions will reduce personal injuries.

- **Prevent unintentional starting. Ensure the switch is in the off-position before connecting to power source and/or battery pack, picking up or carrying the tool.** Carrying power tools with your finger on the switch or energising power tools that have the switch on invites accidents.
- **Remove any adjusting key or wrench before turning the power tool on.** A wrench or a key left attached to a rotating part of the power tool may result in personal injury.
- **Do not overreach. Keep proper footing and balance at all times.** This enables better control of the power tool in unexpected situations.
- **Dress properly. Do not wear loose clothing or jewellery. Keep your hair, clothing and gloves away from moving parts.** Loose clothes, jewellery or long hair can be caught in moving parts.
- **If devices are provided for the connection of dust extraction and collection facilities, ensure these are connected and properly used.** Use of dust collection can reduce dust-related hazards.

<Power tool use and care>

- **Do not force the power tool. Use the correct power tool for your application.** The correct power tool will do the job better and safer at the rate for which it was designed.
- **Do not use the power tool if the switch does not turn it on and off.** Any power tool that cannot be controlled with the switch is dangerous and must be repaired.
- **Disconnect the plug from the power source from the power tool before making any adjustments, changing accessories, or storing power tools.** Such preventive safety measures reduce the risk of starting the power tool accidentally.
- **Store idle power tools out of the reach of children and do not allow persons unfamiliar with the power tool or these instructions to operate the power tool.** Power tools are dangerous in the hands of untrained users.
- **Maintain power tools. Check for misalignment or binding of moving parts, breakage of parts and any other condition that may affect the power tool's operation. If damaged, have the power tool repaired before use.** Many accidents are caused by poorly maintained power tools.
- **Keep cutting tools sharp and clean.** Properly maintained cutting tools with sharp cutting edges are less likely to bind and are easier to control.
- **Use the power tool, accessories and tool bits etc. in accordance with these instructions, taking into account the working conditions and**

the work to be performed. Use of the power tool for operations different from those intended could result in a hazardous situation.

<Service>

- **Have your power tool serviced by a qualified repair person using only identical replacement parts.** This will ensure that the safety of the power tool is maintained.
- **Hold power tool by insulated gripping surface, when performing an operation where the cutting accessory may contact hidden wiring.** Cutting accessory contacting a “live” wire may make exposed metal parts of the power tool “live” and could give the operator an electric shock.

Drill safety warnings

- **Wear ear protectors when impact drilling.**
Exposure to noise can cause hearing loss.
- **Use auxiliary handle(s), if supplied with the tool.**
Loss of control can cause personal injury.

POWER TOOL SAFETY

WARNING

- Always make sure that the machine is properly grounded. If the machine is not properly grounded, someone can get an electric shock.
- If you have any doubt about the grounding of the magnetic drilling machine, contact a licensed electrician.
- Never connect the grounding conductor to a gas pipe. This will result in an explosion and severe injuries or death.
- Always check the grounding conductor. If you have any doubts about the grounding conductor contact a licensed electrician.
- Wiring connections to a grounding rod require the expertise of a licensed electrician. Do not attempt the wire connections yourself. Always contact a licensed electrician.
- Do not abuse the power cord. A damaged power cord can cause an electrocution. A damaged power cord can cause fires. Always inspect the cord. If the cord is damaged, do not use the magnetic drilling machine.
- Do not carry the machine by the cord. Do not pull the cord to disconnect it from a socket.
- The cord can become damaged from heat, contact with sharp objects or from being twisted. Always inspect the cord. Do not use the machine if the cord

is damaged.

- Always use a ground fault circuit interrupter. The use of a ground fault circuit interrupter may be required by government regulations. The failure to use a ground fault circuit interrupter may result in electric shock.
- Avoid starting the magnetic drilling machine abruptly or unintentionally.
- Always make sure that the switch is turned off before connecting the power source.
- Always disconnect the power source and turn off the switch before setting up for work operations. Always disconnect the power and turn off the switch when inspecting work. Always disconnect the power and turn off the switch before attempting any maintenance. Failure to disconnect the power and turn off the switch during set up, inspection or maintenance can cause accidents and severe injuries.

ABOUT YOUR NITTO PORTABLE MAGNETIC DRILLING MACHINE

DANGER

Do not use your portable drilling machine on the ceiling.

- Use of the portable drilling machine on the ceiling is dangerous. The machine could fall. The falling machine could cause severe injuries or death.

WARNING

Do not use the Magnet for more than five hours.

- More than five hours of uninterrupted operation may cause a fire. Five hours of uninterrupted operation generates extreme heat in the Magnet. This heat can cause a fire. Do not touch the Magnet. When the Magnet is hot, touching it will cause a severe burn injury. Never use the Magnet for more than five continuous hours. When you are not using the Magnet, turn the switch to the OFF position and pull the Plug out of the power source.

Do not use the Drill Motor for over 30 minutes.

- Uninterrupted operation of the Drill Motor for over 30 minutes generates heat. This heat can cause a fire. Never use the Drill Motor for over 30 minutes. When you are not using the Drill Motor, turn the switch to the OFF position and pull the Plug from the power source.

Use only on magnetic materials.

- Your portable drilling machine cannot be used on non-magnetic materials, such as aluminum,

stainless steel, copper or alloys. The Magnet will not work on non-magnetic materials. Attempting to use the Magnet on non-magnetic materials could cause an accident.

Use caution during wall operation.

- When using your portable magnetic drilling machine on a magnetic wall, always use caution.
- Never stand under the machine.
 - * Never allow anyone to stand under the machine.
 - * Never put any part of your body under the machine.
 - * If the machine falls, it could result in severe injury or death.
- Always remove Cutting Oil from the Tank before using the machine on a wall. You must manually apply Cutting Oil to the cutting tool.

Always use a work piece that is at least 6 mm thick.

- The work piece must be at least 6 mm thick. If a work piece is too thin, the magnetic power of your machine will decrease. This will cause the machine to move during operation. This could result in an accident.

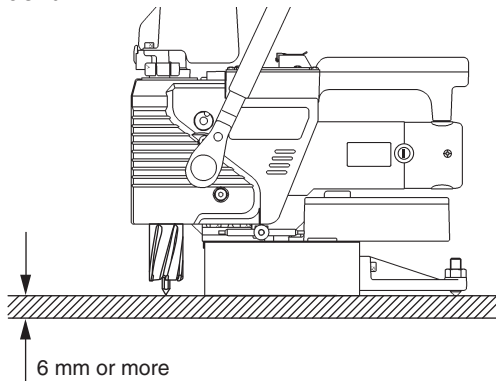

Fig. 1

Use an iron back-up plate.

- If the work piece is less than 6 mm thick, you must use an iron back-up plate that is more than 7 mm in thickness. The surface area of the iron back-up plate must be greater than the surface area of the magnet. An appropriate back-up plate is necessary to boost the holding power of the Magnet. Use of an inappropriate back-up plate can result in an accident, If the back-up plate is not thick enough or big enough, the machine will come loose during operation. This can result in an accident and severe injuries.

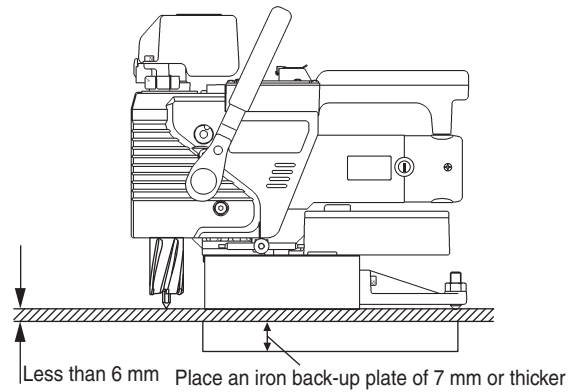

Fig. 2

Always keep surfaces clean.

- Always keep the Magnet surface clean. Always keep the work piece surface clean. If there are any foreign objects between the Magnet and the work piece surfaces, this will reduce magnetic power. This could cause the machine to move during operation. This can result in an accident. Keep all surfaces clean of rust, chips or other foreign material.

Do not place the machine over a hole.

- Do not attempt to position the Magnet over a hole. Attempting to straddle a hole will reduce the power of the Magnet. This will cause the work piece to come loose during operation and can cause an accident.

Use the accessory safety strap to prevent the unit from falling off.

- Use the safety strap to fix the unit to the work piece when there is a risk that it might fall off from a high place or tumble over if for some other reason the power stops and the magnet is lift off. (Fig. 3) Use the supporting magnet Ass'y (option) to prevent unit from falling off when the safety strap cannot be wound around too big work piece.

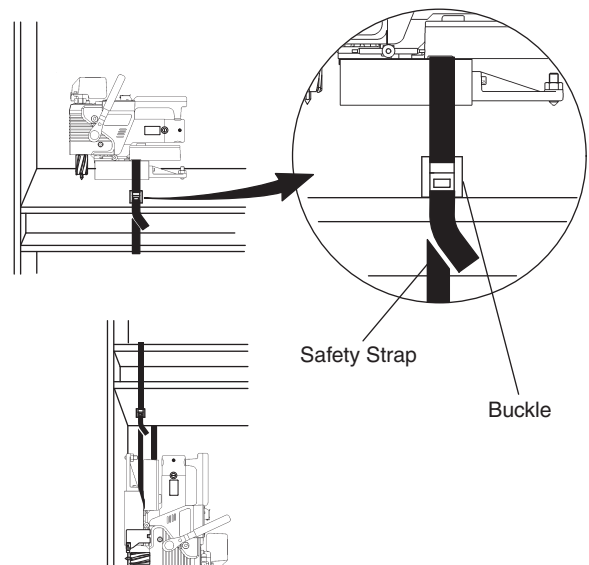

Fig. 3

Align the magnet parallel to the longer direction of the work piece.

- Since the surfaces of both sides of H-beam is normally warped as shown in Fig. 4, the magnet should be placed parallel to the longer direction of the work piece to ensure good adhesion and safe job. Insecure magnetic adhesion is the cause of cutter damage and unexpected accidents.

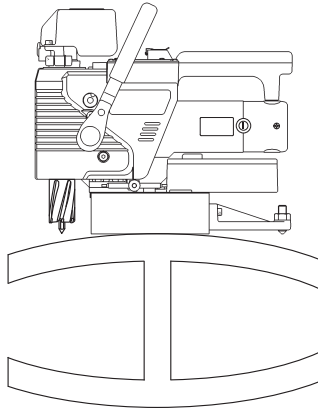

Fig. 4

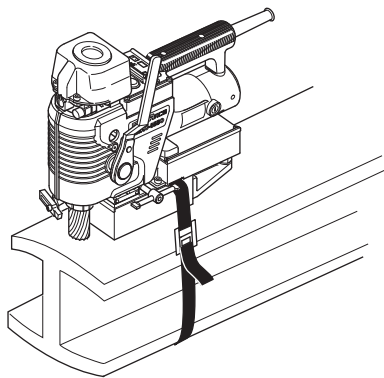

Fig. 5

Be careful about chips.

- Keep your hands away from the cutting area at all times. During drilling, there will be chips. The chips are sharp. The chips are rotating with the cutter. Any contact with the chips can cause severe injuries.

Do not touch the slug.

- Do not touch the slug. The slug is very hot. It will cause severe burns. Make sure that no one touches the slug. Make sure that there is no one below the work area during operation. Hot slugs will fall. Hot slugs can cause severe burns, other severe injuries, or even death. Always wear protective equipment, including protective headgear, eye protection, hearing protection, and gloves. Do not allow any person without protective equipment to come near the machine.

Do not use your hands to remove chips.

- Chips have sharp edges. Use a screwdriver to remove chips. If you use your hands to remove chips, you can be injured, even if you are wearing

gloves. Do not use your hands to remove chips under any circumstances.

The cutting edge is sharp.

- Always wear gloves when changing the cutter. The cutting edge is sharp. If you do not wear gloves, you will be cut. Attempting to change the cutter can result in severe injuries.

Do not use Cutting Oil for other purposes.

- Cutting Oil should be used only for drilling. Please refer to Section 5-6 of this manual for further warnings and instructions about Cutting Oil.

! CAUTION

Always use a compatible Pilot Pin.

- The Pilot Pin must be compatible with the cutter. An improper Pilot Pin may result in an accident. See Section 5-3 to identify compatible Pilot Pins and cutters. The proper Pilot Pin to be used will vary, depending on the type of cutter, the diameter of the cutter, and the length of the cutter.

Do not use power that is generated by an engine-driven welder.

- The use of an engine-driven welder as a power source may cause your magnetic driven machine to malfunction, Power from an engine-driven welder can damage the electronic circuits in your portable drilling machine.

Use a Proper extension cord.

- Do not use an extension cord that is too thin. Do not use an extension cord that is too long. Do not use an extension cord that is wound on a drum. Do not share an extension cord with other motor-driven tools. These uses can cause voltage to drop and can reduce the holding power of the magnetic base, causing the machine to move during operation. This can decrease performance and may cause damage to the machine. (Fig. 6)

Extension Cord	
Max length	Size (nominal cross-section area of the conductor)
10 m	Min 1.25 mm ² or more
20 m	Min 2.00 mm ² or more
30 m	Min 3.50 mm ² or more

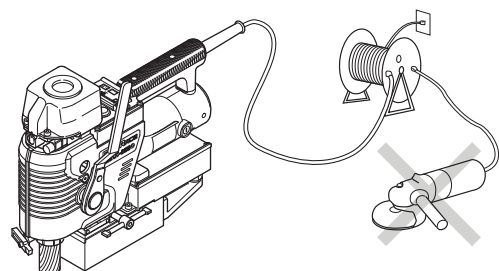

Fig. 6

Don't use this machine on the steel material being electrically welded.

- When the electric welder is not properly grounded, electricity will run through the Atra Ace machine via its Magnet, causing possible failure or malfunctioning, which in turn may cause accident.

Don't force to feed cutter when drilling manually.

- Because the Hi-Broach and Jet-Broach have rather thin cutting edges with less cutting pressure resistance as compared to twist drill, do not force to feed the cutter when drilling manually. If you feed it with too much force, the cutter may break or end up with shorter life than otherwise.

1 APPLICATION

This is a portable drilling machine with a Magnet, geared to drilling mild steel (mild steel or equivalent) using One-Touch type Jet-Broach. The machine will be mounted on the workpiece to be drilled with the Magnet securely fastening the machine to the workpiece while drilling takes place.

2 RECEIVING INSPECTION

Upon unpacking, check to see that the shipment is complete without damage or oil leakage in transport. Should you find any damage or short-shipment, please contact sales agent through which you have purchased your machine or an authorized dealer near you for corrective actions.

Package Contents	Q'ty	Check
ATRA ACE	1set	
Soluble Cutting Oil 0.5ℓ Ass'y	1set	
Handle Ass'y	1set	
Sub Handle Ass'y	1set	
Pilot Pin 08050	1	
Spanner 17	1	
Hex. Socket Head Cap Screw 5×12	1	
Hex. Socket Screw Key 4	1	
Hex. Socket Screw Key 5	1	
Safety Strap	1	
Hex. Socket Screw With Dog Point 8×35	1	
Blade	1	
Guard	1	
Instruction Manual	1	

3 PART NAMES

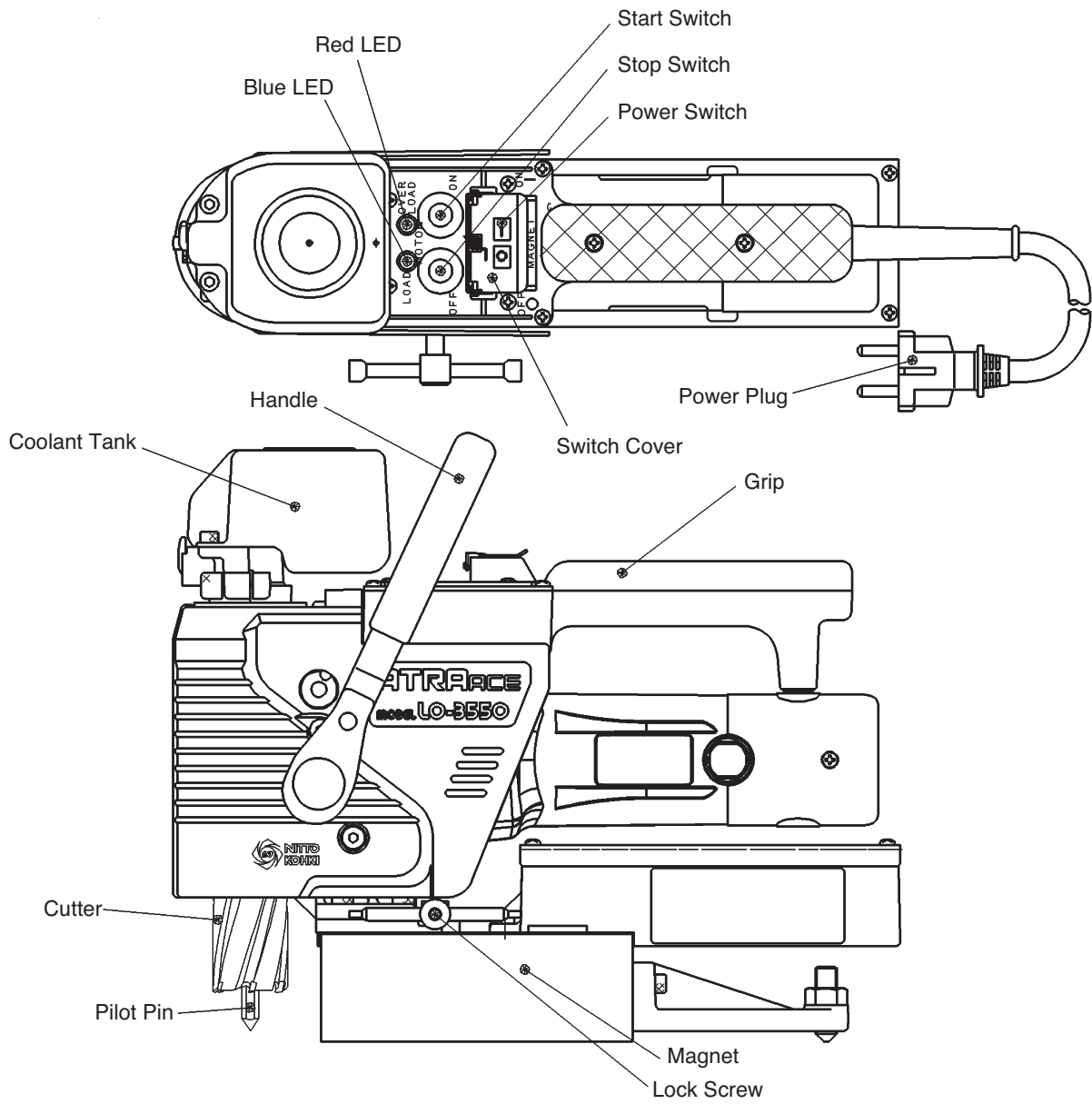

Fig. 7

4 FUNCTIONS OF ELECTRONIC CONTROL

4-1. Overload Detecting Function

When overload is detected during drilling operation, the following automatic functions are activated. Please note, however, that there may be cases where the overload detector does not work properly if power is drawn from an engine generator or power source with too high or too low voltage fluctuation.

(1) Load Indication

Two LED lamps indicate the load conditions on the drill motor. The blue LED lamp is lit under normal load on the drill and the red LED lamp under overload.

(2) Automatic Stop

Overload on the drill motor illuminates the red LED lamp and increasing load on the drill motor will reduce the motor output and the red LED lamp will blink. If the drill motor is further loaded for two seconds, the drill motor will stop automatically for its own protection and the blue LED lamp will blink.

(3) Automatic Re-start

If the load is released before the electric drill comes to a complete stop due to the continued overload, the drill motor will resume its normal operation. When the drill motor comes to a complete stop, you can re-start the drilling by pushing the start switch again.

4-2. Re-start Prevention

The re-start prevention function comes into play when power failure is restored that has occurred during operation.

Thanks to this feature, when the electric plug that has been disconnected during operation is re-plugged into the receptacle or when power failure that has occurred during operation is restored, the drill motor will not re-start automatically preventing possible accident, although magnetic power IS restored.

To resume operation, turn on the start switch which is located on top of the machine to start the drill motor.

4-3. Magnet Interlock

When the Magnet fails, the drill motor will not start revolving and the red LED lamp will blink. To repair defective magnet, please contact the sales agent from whom you purchased your unit or an authorized dealer near you.

5 MACHINE SETUP

WARNING

- When setting up machine, turn off the Magnet Switch and disconnect the power supply plug from power source.

5-1. Accessory Installation

Insert the accessory feed handle into the handle shaft on the side of the body. (Fig. 8)

- ※ The handle bar can be positioned on the right or left side for comfortable drilling and mounting in confined spaces.

See Fig. 9 for the mounting position of the sub handle.

When mounting the sub handle, align the pin on the body to the cutout on the sub handle then assemble as shown in Fig. 9.

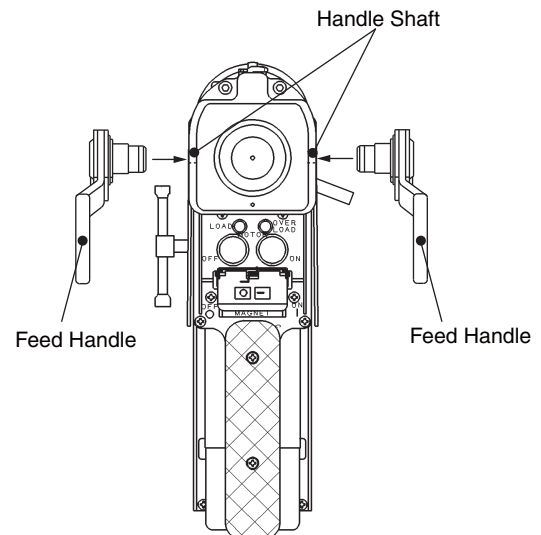

Fig. 8

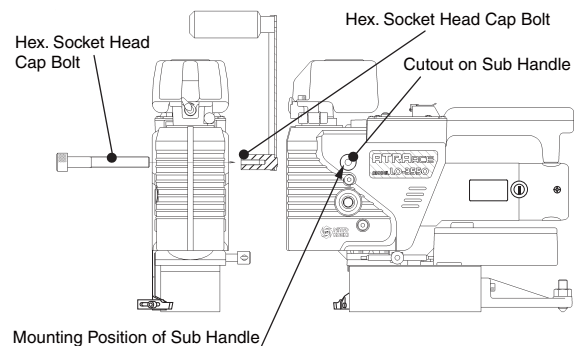

Fig. 9

5-2. Using Cutter

⚠ CAUTION

- Use One-Touch type cutters only.
- For better workability and safety, do not use worn or damaged cutters.

5-3. Combination of Cutter and Pilot Pin

⚠ CAUTION

- Do not use any other combinations than those shown in the compatibility table.

Use a Pilot Pin appropriate for the cutter. (Fig. 10)
 A Pilot Pin to be used varies depending on the cutter type, diameter, length (depth). A wrong combination of cutter and Pilot Pin would not allow slug to be ejected at the end of drilling and/or prevent Cutting Oil from reaching the cutting point, resulting in cutting tool damage.

Diameter (mm)	Depth (mm)	Pert No.	Pilot Pin
12 ~ 17	25L	TK01167	06025 (C1)
	50L	TK01166	06050 (C2)
17.5 ~ 35	35L	TJ15859	08035 (A2)
	50L	TJ16019	08050 (A3)

Fig. 10

5-4. Mounting/Removing Cutter

⚠ WARNING

- Wear safety gloves when replacing cutter.

⚠ CAUTION

- Do not use any other combinations of Pilot Pin and cutter than those shown in the compatibility table.

- (1) Lift the cutter up by turning handle counterclockwise. (Fig. 11)

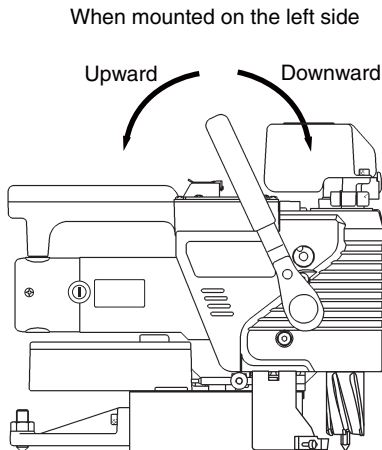

Fig. 11

When mounted on the right side

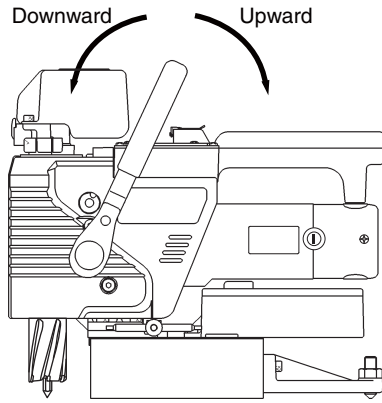
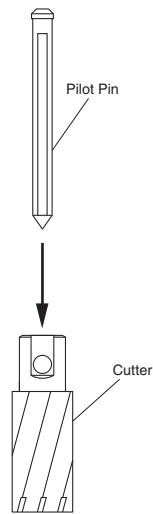
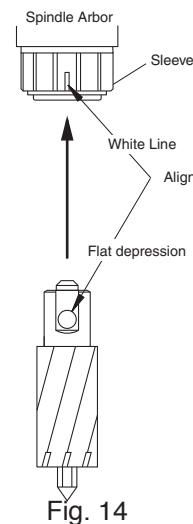

Fig. 12

- (2) Insert a pilot pin, appropriate for the cutter you use, into the cutter. (Fig. 13)



- (3) Align the round depression on the cutter with the white line on the sleeve, then push up the cutter. If you insert the cutter deep to the hilt, the sleeve will turn clockwise and lock by itself with a click.
 ※ When you find it hard to insert the cutter all the way, turn the sleeve counterclockwise to take it out and do the insert all over again.



- (4) To remove the cutter, turn the sleeve counterclockwise. The cutter will come off. (Fig. 15)

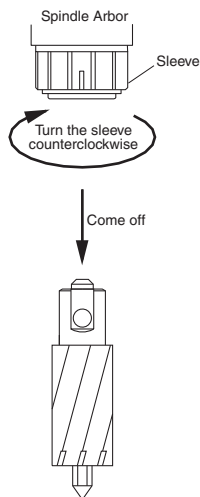

Fig. 15

5-5. Preparation of Cutting Oil

Cutting Oil Safety Precautions



(1) Use

- Use Cutting Oil for cutting purpose only. Don't use it for household purposes.

(2) Handling Precautions

- The Cutting Oil contains amine. Do not mix it up with rust inhibitor, etc. containing nitrite.
- Wear safety glasses for eye protection when handling Cutting Oil: eye injury may result if it gets into your eyes.
- Wear protective gloves for hand protection when handling Cutting Oil: skin injury may result if it comes into contact with your skin.
- Wear respirator when exposure to respiratory hazards with oil mist or vapor is anticipated. Inhalation of oil mist or vapor may make you feel sick.
- When diluting Cutting Oil, follow the instructions per the Operation Manual.
- Keep Cutting Oil out of reach of children.
- Don't drink Cutting Oil.

(3) First Aid

- If Cutting Oil gets into your eyes, immediately open your eyelids with your fingers and wash your eyes with plenty of water for at least 15 minutes. If your eyes feel irritated, consult with a medical doctor and follow his/her instructions.
- If Cutting Oil comes into contact with your skin, immediately wash it away with plenty of water and soap. Take off contaminated clothes. Clean the clothes if you need to wear it again. If your skin feels irritated, consult with a medical doctor for

medical instructions.

- If someone inhales oil mist or vapor, immediately take him/her to an area where fresh air is abundant and wrap up his/her body with a blanket, etc. to keep body temperature. Have him/her take a rest and consult with a medical doctor for medical instructions.

- If someone drinks Cutting Oil, immediately make him/her drink plenty of water and vomit it. Consult with a medical doctor for medical instructions. When unconscious, do not pour water into his/her mouth nor induce him/her to vomit.

(4) Instructions in Case of Fire

- If fire breaks out in the vicinity, wear PPE (personal protective equipment) and use foam, powder or CO² fire extinguisher to put the fire out from the windward.

(5) Storage

- When storing Cutting Oil after use, put it into a container and put a lid on for tight sealing so that dust or moisture, which is a catalyst for contamination, may not get in.
- Avoid direct sunlight, rainwater or the like and store Cutting Oil in a dim cool area.

(6) Disposal

- For disposal of concentrate solution and used fluid, request a waste-disposal company to dispose them as industrial waste in accordance with the local laws and regulations.
- Treat flushing water through pH adjustment, condensation/sedimentation, activated sludge process, activated carbon adsorption, etc., and discharge it in accordance with the regulations of your local municipal bylaw.
- Residual dross will remain in an emptied container: be careful when handling an empty container.

(7) Others

- When Cutting Oil is poured into another container for use, post chemical and label information at the site where it is kept. At the same time, keep the Operation Manual handy so that it can be referred to whenever necessary.
- For further details, contact us for product safety data sheet.
- All the information and descriptions that have been provided are based on the currently available documents and information, which may be revised upon our new recognition and/or discovery.
- The precautions provided apply to regular handling. If special handling method is used, take safety measures that are suitable for your applications and usage.
- The information contained herein is for your

reference purpose only, to which we make no warranty of any kind and for which we shall not be held responsible.

- (1) Always use our genuine cutting oil. With other cutting oil, the cutting performance and service life would be decreased.
- (2) Dilute the cutting oil eight to ten portions of tap water. Do not use well water.
- (3) Fill the diluted cutting oil into the tank container on top of the body. The oil flow control is done as follows.
 - When the front lever is turned to the left cutting oil flows, and turned to the right, stops. (Fig. 16)
 - Filling the tank container with too much cutting oil may cause cutting oil overflow when the cutter is lifted up. The level of cutting oil in the tank container should not be more than as is shown in Fig. 16.

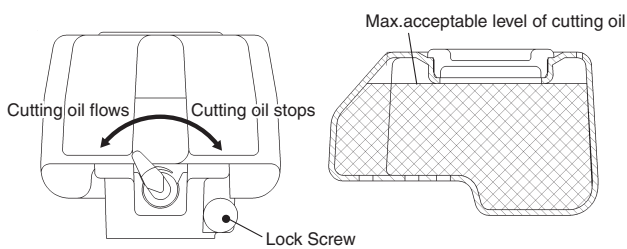

Fig. 16

- Loosen the lock screw and you can allow the tank container to rotate for position change. In perpendicular drilling on standing wall, change the position of tank container so that the air vent of the tank comes on top. (Fig. 17)

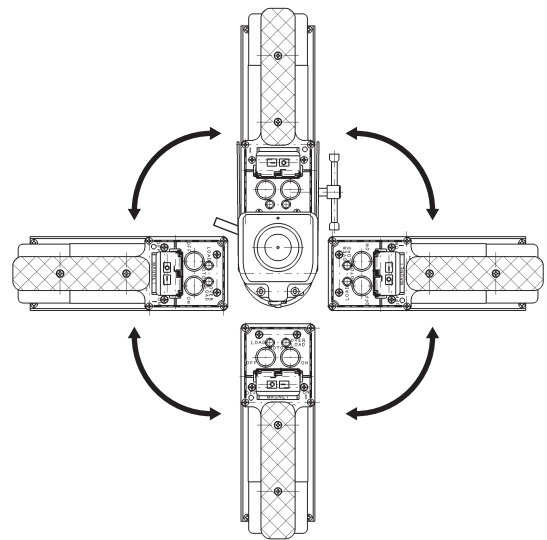

Fig. 17

- (4) Jet Oiler squeeze bottle is available as the optional accessory. Use as follows: Remove the tank container from the unit body. Mount the optional oil supply adapter, tubes, and the Jet Oiler all connected as shown in Fig. 18. Fill up cutting oil into the Jet Oiler.

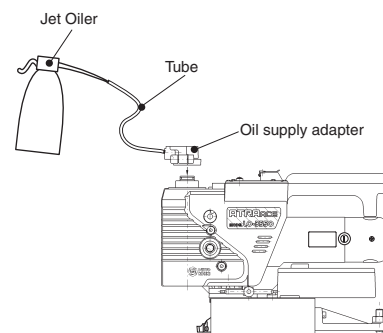

Fig. 18

5-6. Mount Chip Breaker

When setting the chip breaker, see that the tip of blade may not come into contact with the cutting tool. Chip Breaker shreds cutting chips generated in the drilling into small pieces and facilitates chips smooth discharging.

Set the blade

- (1) Mount cutter

Loosen the hex socket head cap screw, and pull the blade away in the direction as shown by the arrow until it would no longer move. And then, mount a cutter.

- (2) Set the blade

Set the blade so that the cutter and the blade will have a clearance of 0.5 – 0.8mm and fasten it securely to the blade stay with hex. socket head cap screws.

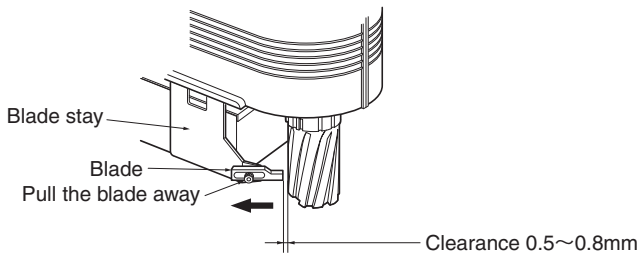

Fig. 19

6 MACHINE OPERATION

⚠ WARNING

- Always Wear Safety Glasses.
- Always Wear Hearing Protection.
- Wear respiratory protective equipment.
- Never touch the mounted cutter and the rotating parts of the machine such as the Spindle Arbor after the power cable is connected to power source.

6-1. Start and Stop

(1) Magnet ON

Turn on the power switch to activate magnetic power. (Fig. 20).

(2) Drill Motor ON

Turn on the start switch to run the drill motor. (Fig. 20)

(3) Stop

Turn off the stop switch to stop the drill motor. Turn off the power switch to deactivate magnet power, and make complete stop.

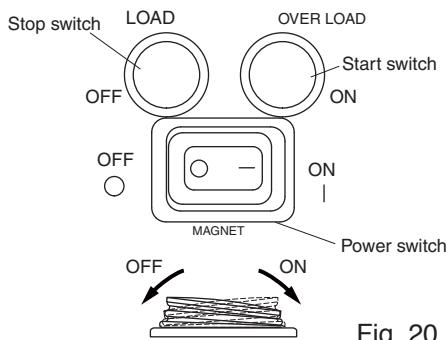

Fig. 20

6-2. How to Use the Feed Handle (Fig. 21)

The socket part of handle has ratchet mechanism. You do not have to remove the handle from the handle shaft every time in order to change the position.

Pulling the handle in the direction of arrow causes the handle to disengage from the handle shaft. While disengaging from the shaft, the handle can be turned to the next lock position. Handle lock positions are fixed at each 60° pitch.

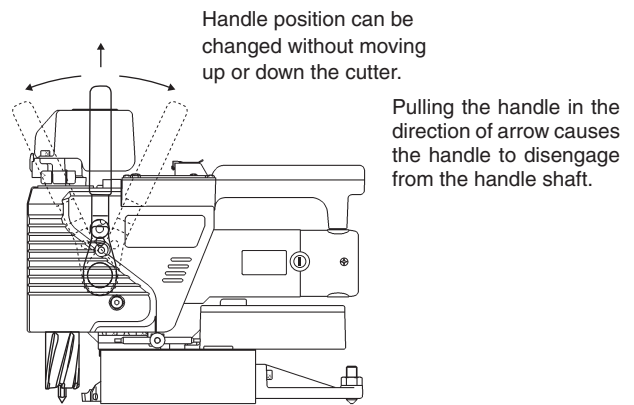

Fig. 21

6-3. Drilling Oblong Hole

⚠ CAUTION

Always drill slowly.

Drill round holes in the order of ①, ②, ③ to get an oblong hole. For the steps ② and ③, take care so that the cutter may not be fed into the work piece with so much force.

File away any remaining excesses. See Fig. 22. Spacing of round holes should be so arranged that the Pilot Pin will always hit the material yet to be machined.

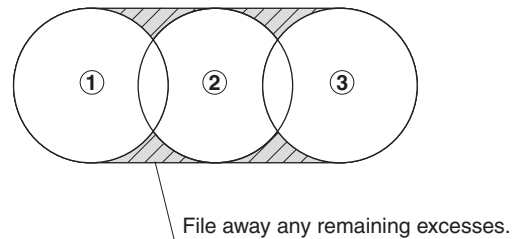

Fig. 22

6-4. Drill Stacked Plates

⚠ CAUTION

- When drilling stacked plates, fix the steel plates so that the gap between the plates must be less than or equal to 1mm.
- Use special one-touch Jetbroach Cutters exclusively designed for stacked plates.

6-5. Drilling Procedure

⚠ CAUTION

(1) Punch Mark

Always a large punch mark should be stamped quite vertical to the work piece. Be careful to get the precise position for the punch mark since it serves as the drilling center guide. (Fig. 23)

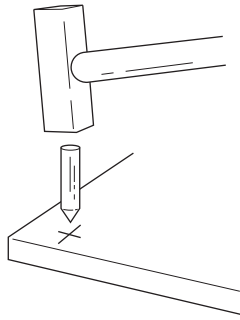

Fig. 23

(2) Make sure to clean the both portions of surface of the work piece where the magnet is placed and the hole is cut.

! WARNING

Always keep the magnet sole clean. Always keep the work piece surface clean. Any foreign object between the magnet and the work piece will reduce magnetic power. This could cause the machine to move around during operation, which may result in an accident. Keep all working surfaces clean and flat without any rust, chips or undulations.

(3) Align with Punch Mark

! WARNING

Make sure that the lock screw to fix body position is securely fastened before drilling.

Loosen the lock screw on the side of the body, and moves the body back and forth or around to align the tip of the pilot pin with the punch. Then tighten the lock screw in the arrow direction. (Fig. 24) The lock screw has the wings and is designed to fasten with hands. Do not tighten it with a spanner or the like.

※ The lock screw can be mounted on either left or right side of the body.

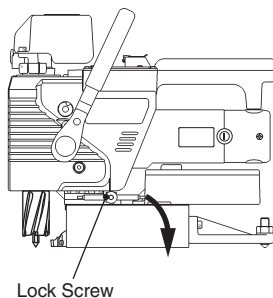

Fig. 24

(4) Magnet ON

! WARNING

Check to see that magnetic power is activated. Turn on the power switch. Magnet will stick to the work piece. (Fig. 25)

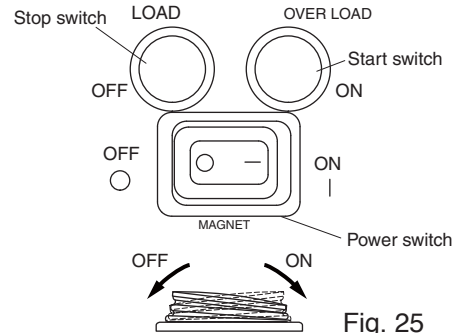

Fig. 25

(5) How to attach the Guard

Please attach the guard as shown in Fig.26.

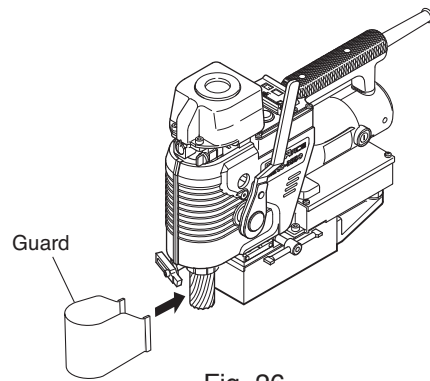

Fig. 26

(6) Drill Motor ON

! WARNING

Do not touch any rotating parts. Press the start switch to activate the drill motor. (Fig. 27)

(7) Drilling

(7-1) Drilling

Turn the Feed Handle downward to start drilling. For the first 2 – 3 mm of the drilling, slowly feed the drill motor. (Fig. 27)

Feed slowly to 2 – 3 mm deep.

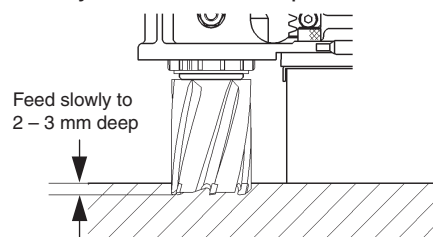

Fig. 27

(7-2) Final stage of drilling

⚠ CAUTION

When drilling a hole in an angle, channel or H-section irons, etc., cutter may be damaged when it comes to the slanted part of the work piece on the final cutting stage. Feed slowly in its start and finish cutting. (Fig. 28)

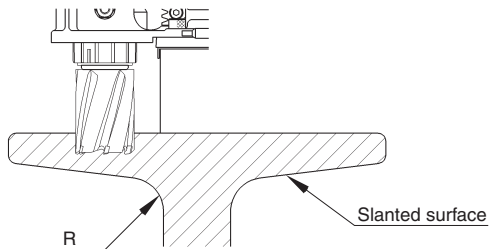

Fig. 28

(7-3) Drilling on the wall

When drilling on the wall, position the cutter at the lower side and the magnet on the upper side. (Fig. 29)

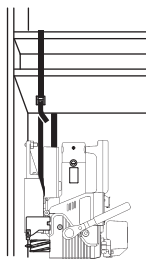

Fig. 29

(8) Finish drilling the hole

⚠ WARNING

Beware of ejecting slug when finish with the hole. Never touch the slug with bare hands since it is hot and sharp.

After complete drilling, turn the Feed Handle to uplift the cutter and press the stop switch.

When the drill motor stops, immediately turn off the power switch. Continuous current flow through the magnet, while it is ON, could shorten the service life of the magnet.

(9) About Remaining Magnet Power

There are some cases that you cannot lift up the magnet because of remaining magnet power even after turning off the switch. The thicker the work piece plate or the finer the surface finish of the plate, more often you will face the case. Follow the following instructions.

Hold the unit at the upper part of the body and the grip then pull down them towards you.

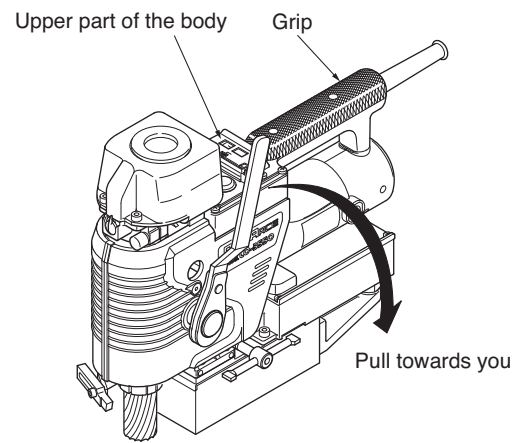

Fig. 30

(10) Removing Slug

⚠ CAUTION

Do not start the next drilling with a slug remaining on the cutter.

The tool has automatic slug discharge system. But when the slug would not come out by turning the feed handle to lift up the cutter, do not try to turn the handle forcefully. This will result in machine troubles.

Upon drilling complete, slug will be ejected automatically pushed out by the spring-operated pilot pin.

Should the slug left choked inside the cutter, turn the handle to lift up the cutter to eject the slug forcefully. When even turning the handle with the same force as in the feed for cutting a hole, you cannot eject the slug, do not turn the handle forcefully any more. Remove the slug from inside the cutter by tapping the collar of the slug with a needle stick or alike. (Fig. 31)

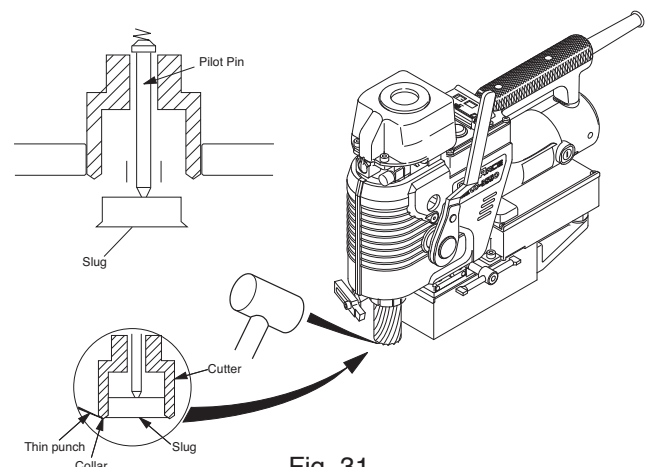

Fig. 31

(11) Lock handle can be replaced with Hex. Socket Head Cap Screw

 CAUTION

The unit body can be moved back and force or sideways to facilitate proper alignment of pilot pin to the punch mark.

When the lock handle interferes the proper alignment due to narrow space proceed hole making in the following manner.

- (1) Dismount the lock handle by turning it counterclockwise.
- (2) Remove the lock handle and put the accessory hex. socket head cap screw in place and tightly fasten with the hex. socket screw key so that the tool body would not move around on the magnet.
- (3) Move the whole unit around to align the tip of pilot pin to the punch mark and turn on the power switch to activate magnetic power. And you may start drilling.

7 TROUBLESHOOTING

 WARNING

- **Never attempt to repair machine yourself: injury or damage to equipment may result.**
- **Please feel free to consult the sales agent through which you have purchase your machine or an authorized dealer, when the following symptoms appear or when you have any questions about our products.**

The machine has electronic control. Be sure to turn off all the switches, pull up the electric drill, and then check the machine, when the operator come across to the following situations such as.

Problem	Causes	Solutions
Switch lamp does not come on when the power switch is turned on.	Power plug is not properly connected to receptacle.	Connect power plug properly to receptacle.
The drill motor would not start and LED lamp brinks in red when the motor switch is turned on.	The magnet is not activated.	Request for repair to check the continuity to the magnet.
The drill motor would not start and LED lamp brinks in blue to red when the motor switch is turned on.	The drill motor or the control circuit has been damaged.	Request for repair.
The drill motor stops during drilling. (The magnet stops working and the power ON lamp is off.)	Power failure or plug was pulled out of power supply.	Restore power or insert power plug back in, then set the start switch on again.
No cutting oil or insufficient cutting oil flow.	The lever is turned to the right.	Turn the lever to the left.
	Coolant tank is empty.	Refill cutting oil into the tank.

8 MAINTENANCE/SERVICE

WARNING

- Always disconnect the power and turn off the switch before attempting any maintenance. Failure to disconnect the power and turn off the switch during set up, inspection or maintenance can cause accidents and severe injuries.
- Check to see periodically that mounting screws are tight. If you find them loose, retighten.

8-1. Keep the drill motor at the lifted up position

Keep the drill motor at the lifted up position while not in use, or for the purpose of safety, when you do not use the machine even for a while if it has a cutter mounted. The pilot pin and/or cutter may have the chance to be damaged if you keep the cutter at the low position while carrying around.

8-2. Keep the Tip of Pilot Pin Sharp

When the tip of pilot pin gets dull, it sometimes fails to seat properly in punched hole, and results in inaccurate hole position. See that the tip is sharp enough from time to time. If you find otherwise, regrind with care or replace as required. Grinding with too much force makes the tip rather dull or softens the pin material to such a degree that it is no longer usable. (Fig. 32)

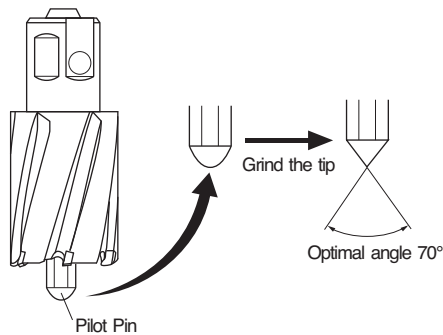

Fig. 32

8-3. Recovery Measures When Pilot Pin Gets Jammed

To replace the cutter, dismantle the cutter from drill and remove the pilot pin from the old cutter and insert it into the new replacement cutter. The pilot pin serves as the guide for the cutter centering. However there are cases the pin would not come off easily because cutting chips in the clearance between the cutter and pin, cause jamming. In such, tap the tip of the pilot pin with a WOODEN hammer alike to push it out.

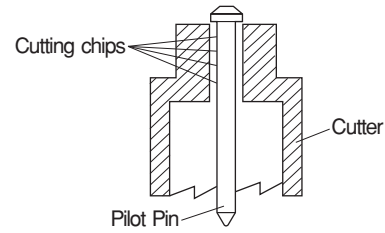

Fig. 33

8-4. Cutter Regrinding

When you need to regrind our cutters, please contact sales agent through which you have purchased or an authorized dealer near you.

8-5. Carbon Brushes Inspection and Replacement

Check Carbon Brushes for wear periodically.

When the length of Carbon Brushes gets as short as 6mm, replace it with a new one, for, if you don't, chances are that you'll have a rectification problem which may cause machine failure. (Fig. 34)

Check - machine failure.

- (1) Remove the Brush Cap with a straight slot screwdriver.
- (2) Remove the worn-out Carbon Brush and replace it with a new one. Then reattach the Brush Cap.
- (3) After replacing the Brush, operate the unit for about ten minutes with no load.

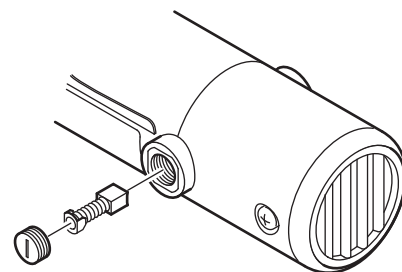

Fig. 34

9 OPTIONAL PARTS

9-1. Nitto-Brand Cutting Oil



Use Nitto-brand Cutting Oil for Atra Ace.

Part No.	Part Name
TB01507	Cutting Oil 2 ℓ (Light Blue)

9-2. Pilot Pin (metric size)

Part No.	Part Name
TK01167	Pilot Pin 06025 (C1)
TK01166	Pilot Pin 06050 (C2)
TJ15859	Pilot Pin 08035 (A2)
TJ16019	Pilot Pin 08050 (A3)

9-3. Supporting Magnet Ass'y

Part No.	Part Name
TB04374	Supporting Magnet Ass'y

9-4. Jet Oiler

Part No.	Part Name
TQ10581	Jet Oiler
TQ05275	Tube 4×7×1000
TB07306	Lubrication Adapter Ass'y

9-5. Cutter

Jetbroach One-Touch Type

Part No.	Diameter x Depth (mm)	Pilot Pin	Part No.	Diameter x Depth (mm)	Pilot Pin
TK01148	12 x25	C1	TK01154	12 x50	C2
TK01149	13 x25		TK01155	13 x50	
TK01150	14 x25		TK01156	14 x50	
TK01151	15 x25		TK01157	15 x50	
TK01152	16 x25		TK01158	16 x50	
TK01153	17 x25		TK01159	17 x50	
TK00301	17.5x35		TK00380	17.5x50	
TK00302	18 x35	TK00381	18 x50		
TK00303	18.5x35	TK00382	19 x50		
TK00304	19 x35	TK00383	19.5x50		
TK00305	19.5x35	TK00384	20 x50		
TK00306	20 x35	TK00385	20.5x50		
TK00307	20.5x35	TK00386	21 x50		
TK00308	21 x35	TK00387	21.5x50		
TK00309	21.5x35	TK00388	22 x50		
TK00310	22 x35	TK00389	22.5x50		
TK00311	22.5x35	TK00390	23 x50		
TK00312	23 x35	TK00391	23.5x50		
TK00313	23.5x35	TK00392	24 x50		
TK00314	24 x35	TK00393	24.5x50		
TK00315	24.5x35	TK00394	25 x50		
TK00316	25 x35	TK00395	26 x50		
TK00317	26 x35	TK00396	26.5x50		
TK00318	26.5x35	TK00397	27 x50		
TK00319	27 x35	TK00398	28 x50		
TK00320	28 x35	TK00399	29 x50		
TK00321	29 x35	TK00400	30 x50		
TK00322	30 x35	TK00401	31 x50		
TK00323	31 x35	TK00402	32 x50		
TK00324	32 x35	TK00403	33 x50		
TK00325	33 x35	TK00404	34 x50		
TK00326	34 x35	TK00405	35 x50		
TK00328	35 x35				

For piling board Jetbroach One-Touch Type

Part No.	Diameter x Depth (mm)	Pilot Pin	Part No.	Diameter x Depth (mm)	Pilot Pin
TK01068	18 x50	A3	TK00625	26 x50	A3
TK00622	22 x50		TK00632	26.5x50	
TK00623	24 x50		TK00626	28 x50	
TK00631	24.5x50		TK00627	32 x50	
TK00624	25 x50		TK00628	35 x50	

10 ATRA ACE LO-3550 MOTOR ASSEMBLY AND PARTS LIST

WARNING

This diagram is for reference only. Do not attempt to service or repair the Nitto Portable Magnetic Drilling Machine. Do not take the machine apart. Contact an authorized Nitto dealer for all service and repair of the machine. Improper service and repair can cause accidents and severe injuries. Never attempt to modify the machine. Never attempt to service or repair the machine yourself.

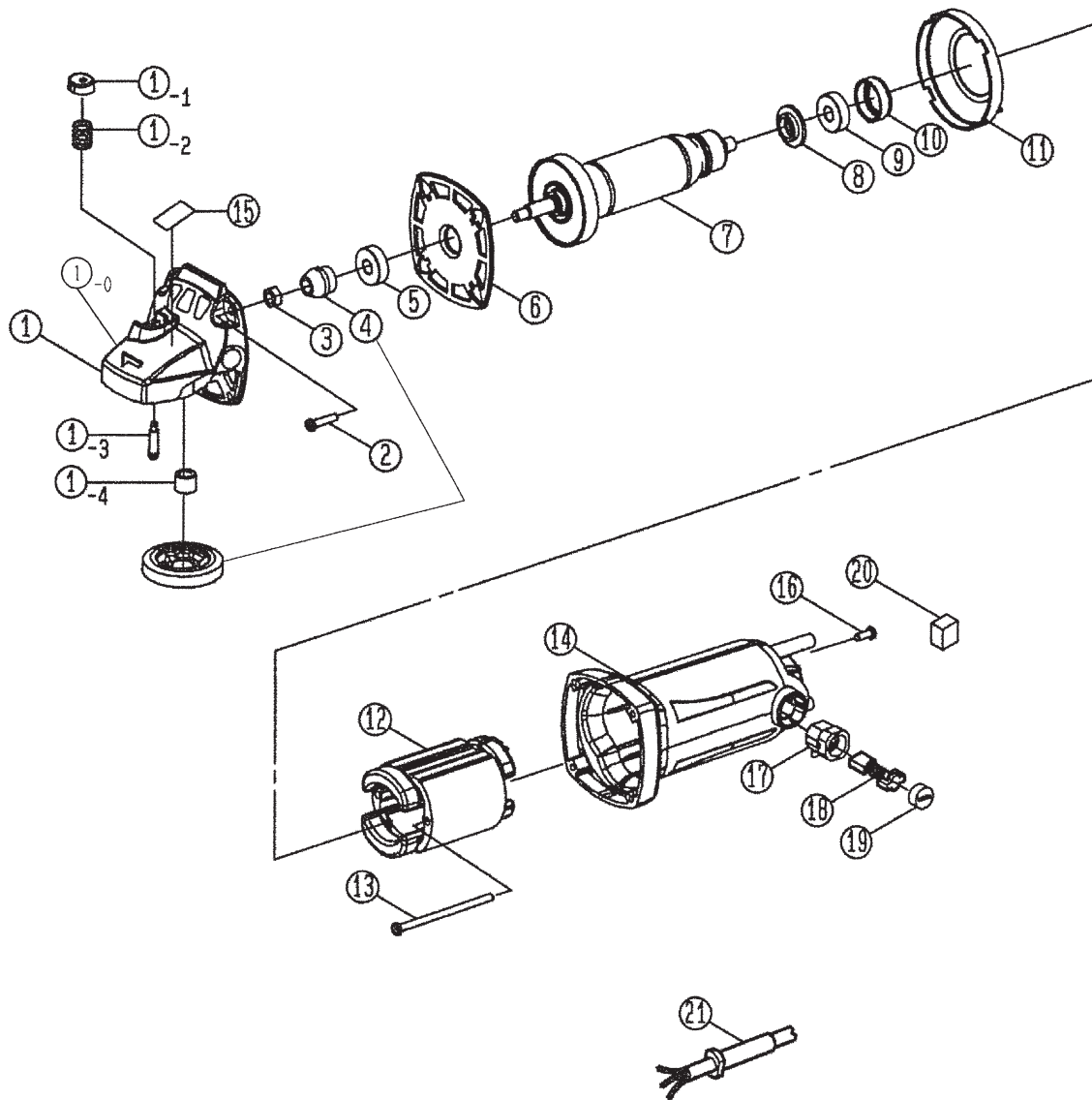

No.	Parts No.	Parts Name	Q'ty
1	TB09024	Gearhousing Ass'y	1set
1-0	(TQ13278)	Gearhousing	1
1-1	(TQ13257)	Lock Button	1
1-2	(TQ13258)	Lock Spring	1
1-3	(TQ13259)	Stopper Pin	1
1-4	(TQ13260)	Needle Bearing	1
2	TQ07488	Pan Head Tapping Screw B 4x18	4
3	TQ14498	Hex. Nut M6 SOB	1
4	TB07094	Bevel Pinion Gear Ass'y	1set
5	TQ13263	Ball Bearing 608LLB	1
6	TQ13264	Bearing Retainer	1
7	TQ13273	Armature 230V LO3550	1
8	TQ10540	Dustproof Cover	1

No.	Parts No.	Parts Name	Q'ty
9	TQ13263	Ball Bearing 608LLB	1
10	TQ10541	Bearing Gum	1
11	TQ13266	Fan Casing	1
12	TQ13274	Stator 230V LO3550	1
13	TQ10544	Pan Head Tapping Screw B 4x70	2
14	TQ13268	Motor Case	1
15	TQ13275	Voltage Display Label LO3550 230V	1
16	TQ07503	Pan Head Tapping Screw B 4x12	2
17	TQ13270	Brush Holder	2
18	TB08837	Carbon Brush	1set
19	TQ13107	Brush Cap	2
20	TQ13272	Connector Block	1
21	TQ10398	Code Armor	1

11 ORDERING PARTS

When ordering parts from sales agent, please be sure to give them part number, part name and quantity.

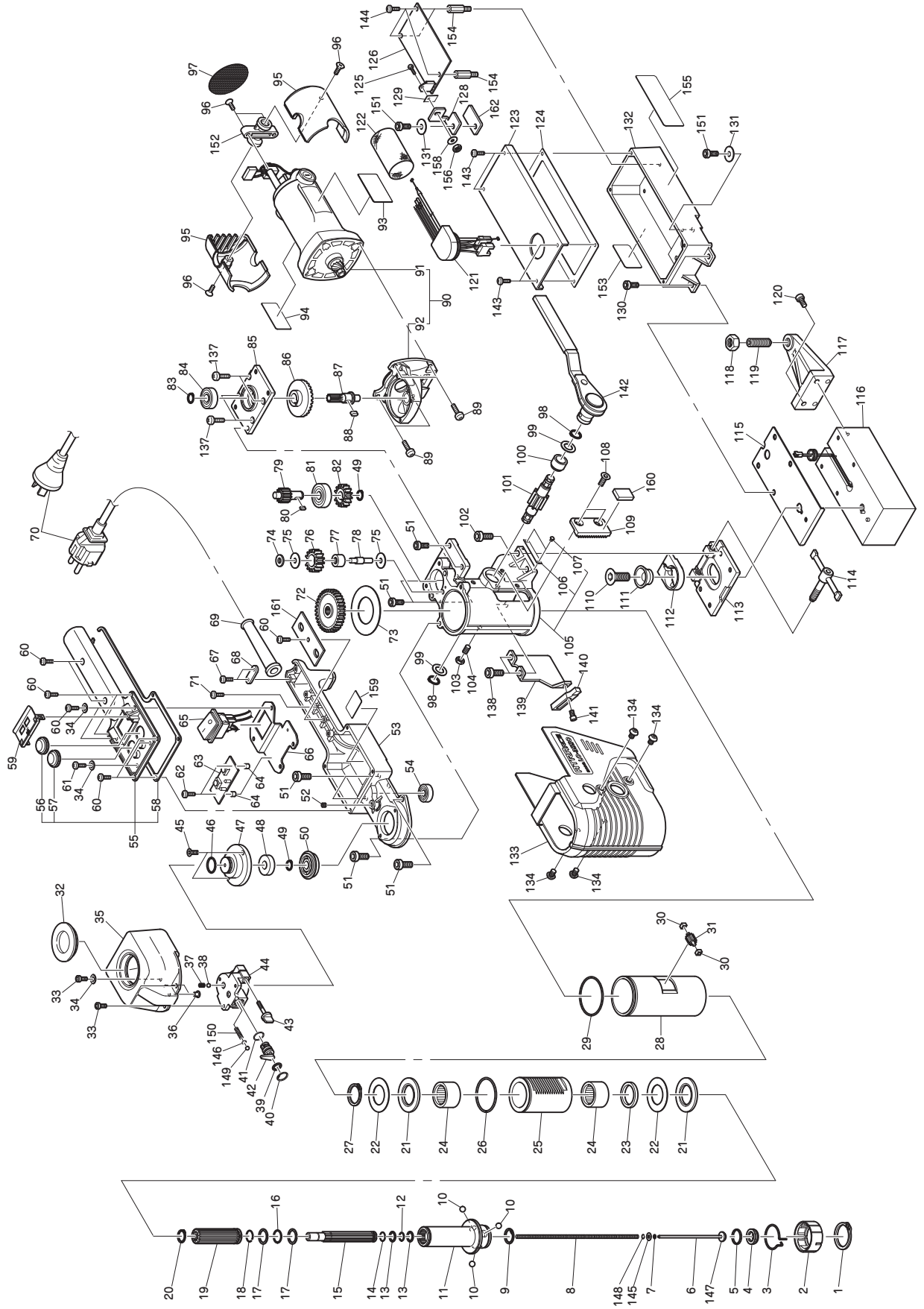

No.	Part No.	Part Name	Q'ty	Price
1	TP15239	External Retaining Ring C-28	1set	
2	TQ01897	Sleeve	1	
3	TQ10750	Rotating Spring	1	
4	TB07023	Push Ring Assy	1set	
5	TQ10547	Y Packings NB 15x19x1.6	1	
6	TQ11527	Push Rod	1	
7	TQ10395	Oil Ring ss020	1	
8	TQ10735	Spring 0.6x4.1x220	1	
9	TQ05006	Internal Retaining Ring IRTW-19	1set	
10	TB01672	Ball 5/16 Assy	1	
11	TQ10728	Arbor	1	
12	TP12004	O-Ring P-10	2	
13	TP05873	Back Up Ring P-10 T2	2	
14	TQ10290	Stop Ring 0-0.8x10.5	1	
15	TQ10729	Spline Shaft	1	
16	TP12010	O-Ring P-14	1	
17	CP26543	Back Up Ring P-15 T2	2	
18	TQ10289	Stop Ring 0-0.8x16.3	1	
19	TQ10730	Double Spline Shaft	1	
20	TQ10368	External Retaining Ring C-13	1	
21	TQ10374	Thrust Bearing	2	
22	TQ10373	Thrust Washer AS1105	2	
23	TQ05259	Oil Seal G25x32x4	1	
24	TQ10375	Needle Bearing HK2520	2	
25	TQ10731	Quill	1	
26	TP03992	O-Ring S-40	1	
27	CQ02200	External Retaining Ring C-25	1	
28	TQ10739	Quill Guide	1	
29	TQ10376	O-Ring S-46	2	
30	TQ10801	Bush 6x4	1	
31	TQ10733	Spur Gear 1.0x8	1	
45	TP16219	Hex Socket Countersunk Head Screw 4x10	2	
46	TP13275	O-Ring P-16	1	
47	TQ10761	Seal Holder	1	
48	TQ10769	Oil Seal AC0279A0	1	
49	TP04595	External Retaining Ring C-10	2	
50	TQ10370	Ball Bearing 6200LLUNR	1	
51	TP00126	Hex Socket Head Cap Screw 5x16	8	
52	TP04195	Hex Socket Set Screw With Flat Point 5x5	1	
53	TQ10727	Gearbox Cover	1	
54	TQ14491	Ball Bearing 608ZZ	1	
55	TB07262	Grip Sub Assy	1set	
56	(TQ12137)	Cap Red	1	
57	(TQ12138)	Cap Blue	1	
58	(TQ10790)	Packing Grip	1	
59	TB07060	Switch Cover Assy	1set	
60	TP02618	Pan Head Screw 4x8	9	
61	TP15164	Pan Head Screw 4x16	2	
62	TQ01184	Pan Head Screw 3x12	2	
63	TB07229	Switch Board Assy	1set	
64	TQ10432	Spacer EP-5	2	
65	TB08840	Rockers Switch Assy	1set	
66	TQ10748	Switch Stay	1	
67	TP09433	Pan Head Screw 4x10	2	
68	TP14459	Cord Stopper	1	
69	TQ10398	Code Armor	1	
70	TB08731	Cable Assy	1set	
	TB09030	Cable Assy (China)	1set	

No.	Part No.	Part Name	Q'ty	Price
71	LP08489	Binding Head Screw 4x6	1	
72	TQ10831	Spare Gear 1.5x29	1	
73	TQ10749	Washer 34x54x1.2	1	
74	TQ 10840	Spacer 6.6x14.5x2	2	
75	TQ10841	Washer 9.1x19x1	2	
76	TQ10832	Spur Gear 1.5x16	1	
77	TQ10839	Needle Bearing HMK0810	1	
78	TQ10834	Gear Shaft	1	
79	TQ10833	Gear Spindle	1	
80	TQ11036	Parallel Key 4x4x7 Both ends round	1	
81	TP03675	Ball Bearing 6200ZZ	1	
82	TQ10745	Spur Gear 1.0x25	1	
83	TP03791	External Retaining Ring G-10 IWATA	1	
84	TQ14490	Ball Bearing 6000ZZ	1	
85	TQ10740	Motor Flange	1	
86	TQ10397	Bevel Gear 38	1	
87	TQ10744	Gear Spindle 7	1	
88	TQ14604	Parallel Key 4x4x9.5 Both ends round	1	
89	TQ13012	Pan Head Tapitite Screw B 4x18	4	
90	TB08682	Motor Sub Assy	1set	
91	(TB08724)	Motor Sub Assy A	1set	
92	(TQ13040)	Gear housing	1	
93	TQ12799	Label Warning	1	
94	TQ12800	Label Nitto	1	
95	TQ12809	Motor Cover	2	
96	TP14488	Pan Head Tapping Screw 4x20	4	
97	TQ10387	Dustproof filter φ54	1	
98	TP06390	External Retaining Ring C-11	2	
99	TQ10737	Washer 11.2x21x1	2	
100	TQ10743	Sleeve	1	
101	TQ10742	Pinion Shaft	1	
102	TP01644	Hex Socket Head Cap Screw 6x12	4	
103	TP07419	Hex Nut M6 SOB	1	
104	TQ10772	Hex Socket Set Screw with Dog Point 6x12	1	
105	TB07260	Body Sub Assy	1set	
106	(TQ10804)	Serial Number Plate	1	
107	(TP05136)	Drive Rivet NO.2x4.8	2	
108	TQ10773	Hex Socket Countersunk Head Screw 6x10	2	
109	TQ10736	Rack	1	
110	TP14176	Hex Socket Countersunk Head Screw 10x25	1	
111	TQ10347	Radial Shaft	1	
112	TQ10348	Lock Plate	1	
113	TB07047	Pole Plate Assy	1set	
114	TB07068	Lock Screw Assy	1set	
115	TQ10799	Pole Seat	1	
116	TB08727	Square Pole with Pin Assy	1set	
117	TQ10751	Stabilizer	1	
118	TP10771	Hex Nut M10 SOB	1	
119	TQ13013	Stabilizer Bolt	1	
120	TP00126	Hex Socket Head Cap Screw 5x16	2	
121	TB08744	Harness Assy	1set	
122	TQ13323	Net tube 0.15m	1	
123	TQ12802	Electrical Equipment Plate	1	
124	TQ12804	Packing Electrical Equipment Box	1	
125	TQ13016	Hex Socket Head Cap Screw 3x10	1	

No.	Part No.	Part Name	Q'ty	Price
126	TB08726	Spare Control Board Assy	1set	
128	TQ13001	Heat Radiation Plate	1	
129	TQ10553	Heat Radiation Seat CW-4	1	
130	TP00021	Hex Socket Head Cap Screw 5x10	2	
131	TQ10388	Seal Washer M5	2	
132	TQ12801	Electrical Equipment Box	1	
133	TQ10757	Cover	1	
134	TQ10846	Hex Socket Head Cap Screw 6x8	4	
137	TQ10836	Pan Head Tapping Screw M4x12	4	
138	TQ10851	Hex Socket Head Cap Screw 6x15	2	
139	TQ10850	Blade Stay	1	
143	TP02618	Pan Head Screw S M4x8	4	
144	TQ03193	Pan Head Screw S M4x6	3	
145	TQ11525	Washer 2.8x5.5x0.5	1	
147	TQ10292	Flange	1	
148	(TQ11526)	Stop Ring O-2.4x0.4	1	
151	TP00126	Hex Socket Head Cap Screw 5x16	2	
152	TQ12807	Spacer	1	
153	TQ11565	Label Arbor Warning	1	
154	TQ13014	Spacer 4SQ-7	3	
155	TQ14493	Label Type	1	
156	TP00242	Hex Nut M3	1	
158	LP13569	Washer M3	1	
159	TQ12975	Insulation Sheet	1	
160	TQ10847	Packing Rock	1	
161	TQ13408	Plate	1	
162	TQ13919	Heat Radiation Sheet	1	

ACCESSORIES

No.	Part No.	Part Name	Q'ty	Price
140	TQ10787	Blade	1	
141	TP01945	Hex Socket Head Cap Screw 5x12	1	
	TB02145	Soluble Cutting Oil 0.5 l Assy	1set	
	TB05998	Handle Assy	1set	
	TB07246	Sub Handle Assy	1set	
	TJ15859	Pilot Pin 08035	1	
	TP00474	Spanner 17	1	
	TP01939	Hex Socket Screw Key 4	1	
	TP14091	Spanner 7x8	1	
	TQ10075	Safety Strap	1	
	TQ10489	Hex Socket Set Screw with Dog Point 8x28	1	
	TQ12808	Instruction Manual	1	
32	(TQ06785)	Rubber Cap	1	
33	(CP24618)	Hex Socket Head Cap Screw 4x8	3	
34	(TQ00258)	Seal Washer M4	5	
35	(TQ10759)	Oil Tank	1	
36	(TQ10782)	Packing Oil Tank	2	
37	(TQ10856)	Spring 0.3x3.7x6.9	1	
38	(TQ10838)	Rubber Ball φ4	1	
39	(TQ13015)	Washer 8.5x12x1.2	1	
40	(TQ12923)	Internal Retaining Ring RTW-13	1	
41	(P11997)	O-Ring KS-7	1	
42	(TQ12920)	Adjustment Valve	1	
43	(TQ10784)	Lock Screw	1	
44	(TQ12919)	Oil Tank Holder	1	
146	(TQ12922)	O-Ring SS-3	1	
149	(CP00922)	Ball 5/32	1	
150	(TQ13022)	Spring 0.2x1.8x7	1	
	TQ14333	Guard	1	

The part numbers with () are include in the Assy part written above them.

Overseas Affiliates / Offices
NITTO KOHKI U.S.A., INC.

46 Chancellor Drive, Roselle, IL 60172 U.S.A.

Tel:(1)-630-924-9393 Fax:(1)-630-924-0303

NITTO KOHKI EUROPE CO., LTD.

 Unit A5, Langham Park Industrial Estate,
Maple Road, Castle Donington,
Derbyshire DE74 2UT, U.K.

Tel:(+44)-1332-653800 Fax:(+44)-1332-987273

NITTO KOHKI DEUTSCHLAND GMBH

Lerchenstr.47 D-71144 Steinenbronn, Germany

Tel:(49)-7-157-22436 Fax:(49)-7-157-22437

NITTO KOHKI CO., LTD., SINGAPORE BRANCH

 10 UBI CRESCENT #01-62,
UBI TECHPARK LOBBY D, SINGAPORE 408564,

Tel:(65)-6227-5360 Fax:(65)-6227-0192

NITTO KOHKI AUSTRALIA PTY. LTD.

 77 Brandl St., Brisbane Technology Park,
Eight Mile Plains QLD 4113 Australia

Tel:(61)-7-3340-4600 Fax:(61)-7-3340-4640

NITTO KOHKI CO., LTD.,
BANGKOK REPRESENTATIVE OFFICE

 M&A Business Center 38Q, House Convent Bldg.,
7th Floor, Unit 7A, Convent Rd., Silom, Bangrak,
Bangkok 10500 Thailand

Tel:(66)-2-632-0307 Fax:(66)-2-632-0308

NITTO KOHKI (SHANGHAI) CO., LTD.

 Room1506, suite C, Orient International Plaza,
NO85 LouShanGuan Road,Shanghai, 200336, CHINA

Tel: (86)-21-6415-3935 Fax:(86)-21-6472-6957

NITTO KOHKI CO., LTD.,
SHENZHEN REPRESENTATIVE OFFICE

 2005C Shenzhen ICC Tower, Fuhuasanlu 168, Futian District,
Shenzhen, Guangdong, 518048 China

Tel: (86)-755-8375-2185 Fax:(86)-755-8375-2187

EC DECLARATION OF CONFORMITY

We hereby declare that the following our product conforms with the essential health and safety requirements of EU Directives.

Product : PORTABLE MAGNETIC DRILLING MACHINE

Model : ATRA ACE : LO-3550

Serial No : In the case of 6 digits serial number.

X X X X X X

↳ Consecutive numbers (00001~99999)

↳ Last digit (0-9) of year (A.D.)

In the case of 7 digits serial number.

X X X X X X X

↳ Consecutive numbers (00001~99999)

↳ Last digit (00-99) of year (A.D.)

Manufacturer : NITTO KOHKI Co., Ltd.

2-9-4, Nakaikegami, Ohta-ku, Tokyo, 146-8555, Japan

Authorized person to prepare the technical construction file(TCF) in the community :

Masatoshi Ogue

President

NITTO KOHKI EUROPE Co., Ltd.

 Unit A5, Langham Park Industrial Estate, Maple Road,
Castle Donington, Derbyshire DE74 2UT, U.K.

Tel:(44)-1332-653800 Fax:(44)-1332-987273

Directive : 2006/42/EC Machinery Directive

2014/30/EU EMC Directive

2011/65/EU RoHS Directive

The above product has been evaluated for conformity with above directives using the following European standards. The technical construction file (TCF) for this product is retained at the above manufacturer's location.

Machinery Directive : EN60745-1 2009, EN60745-2-1 2003+A1 2008

EMC Directive :

EMI

EN55014-1 2006+A1 2009+A2 2011

EN61000-3-2 2006+A1 2009+A2 2009

EN61000-3-3 2008

EMS

EN55014-2 :1997+A1 2001+A2 2008

EN61000-4-2 2009, EN61000-4-4 2012

EN61000-4-5 2006, EN61000-4-6 2009

EN61000-4-11 2004

RoHS Directive : EN50581 2012

Signature : _____

Date/Place : _____ /Tokyo, Japan

 Name : Katsunobu Kishi

 Title : General Manager MACHINE TOOLS Business Div.

NITTO KOHKI Co., Ltd.

2-9-4, Nakaikegami, Ohta-ku, Tokyo, 146-8555, Japan

Being the responsible person appointed and employed the manufacturer.