

Inverter Welder

INSTRUCTION MANUAL

MIG160/200/250/300/315

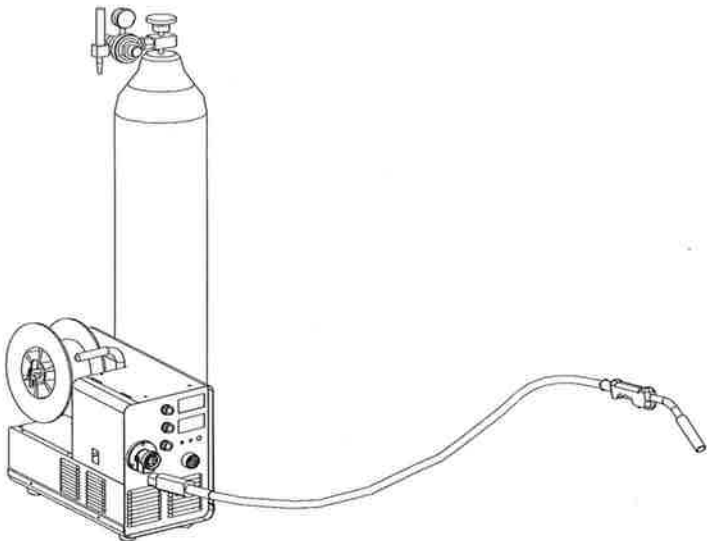

- Safety.....	2
- General Description.....	4
- Main Parameter.....	5
- Installation & Operation.....	
- Speed-read Table.....	10
- Caution.....	12
- Maintenance.....	13
- Daily Checking.....	14

This welding equipment for industrial and professional use is in conformity with IEC 60974 International Safety Standard.

Hereby we state that we provide one year of guarantee for this welding equipment since the date of purchase.

Please read and understand this instruction manual carefully before the installation and operation of this equipment.

The contents of this manual may be revised without prior notice.

This instruction manual is issued on Apr. 17th 2007.

SAFETY

Welding and cutting is dangerous to the operator, people in or near the working area, and the surrounding, if the machine is not correctly operated. Therefore, the performance of welding/cutting must only be under the strict and comprehensive observance of all relevant safety regulations. Please read and understand this instruction manual carefully before the installation and operation.

- The switching of function modes is possibly damaging to the machine, while the welding operation is performed.
- Do not disconnect the electrode-holder cable with the machine, before the performance of welding.
- A safety switch is necessary to prevent the machine from electric-leakage.
- Welding tools should be of high quality.
- Operators should be qualified.

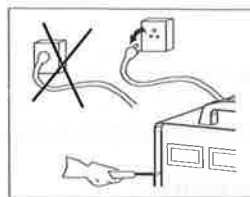

Electric shock: It can kill.

Connect the earth cable according to standard regulation.

Avoid all contact with live electrical parts of the welding circuit, electrodes and wires with bare hands. It is necessary for the operator to wear dry welding gloves while he performs the welding task. The operator should keep the working piece insulating from himself/herself.



Smoke and gas generated while welding or cutting: harmful to people's health.

Avoid breathing the smoke and gas generated while welding or cutting. Keep the working area in good ventilation.

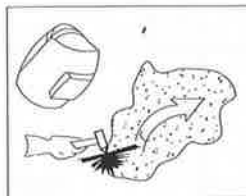

Arc rays: harmful to people's eyes and skin.

Wear welding helmet, anti-radiation glass and work clothes while the welding operation is performed.

Measures also should be taken to protect people in or near the working area.

Arc rays: harmful to people's eyes and skin.

Wear welding helmet, anti-radiation glass and work clothes while the welding operation is performed. Measures also should be taken to protect people in or near the working area.

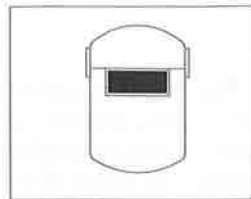

Fire hazard

The welding splash may cause fire, thus remove flammable material away from the working place. Have a fire extinguisher nearby, and have a trained person ready to use it.

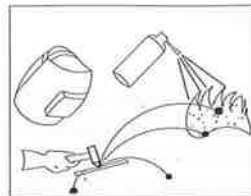

Noise: possibly harmful to people's hearing.

Noise is generated while welding/cutting, wear approved ear protection if noise level is high.

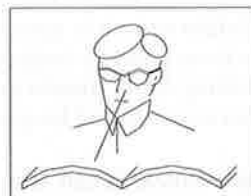

Machine fault:

Consult this instruction manual.

Contact your local dealer or supplier for further advice.

GENERAL DESCRIPTION

This welding machine is manufactured with advanced inverter technology. With high-power component IGBT and PWM technology, the inverter convert the DC voltage, which is rectified from input 50Hz/60Hz AC voltage, to high-frequency 20KHz AC voltage; as a consequence, the voltage is transformed and rectified.

The features of this product are as follows:

- IGBT inverter technology, current control, high quality, stable performance;
- Closed feedback circuit, invariable voltage output, great ability of balance voltage up to $\pm 15\%$;
- Electron reactor control, stable welding, little splash, deep melting, excellent welding seam reshaping;
- Slow weld wire feeding for arc starting, be able to cut small ball after welding, successful arc starting;
- Suit for welding medium thin plate more than 0.8mm;
- Small-sized, light-weighed, easy to operate, economical, practical.

The efficiency of this machine can reach up to 85%, and save energy by 30% compared with the traditional machine.

Block Diagram

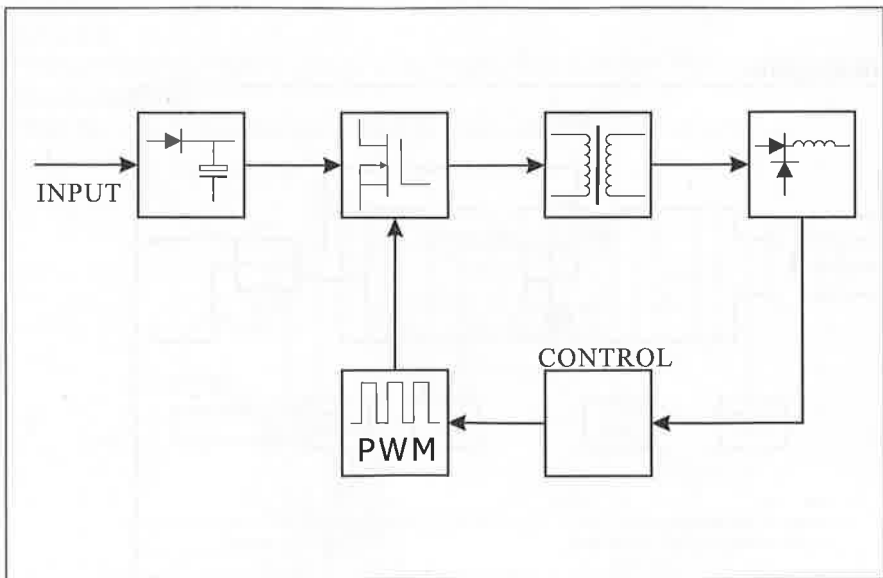

TYPE	MIG160	MIG200	MIG250	MIG250	MIG300	MIG315
Input Voltage(VAC)	single phase 220±15%	single phase 220±15%	single phase 220±15%	three phase 380±10%	three phase 380±10%	three phase 380±10%
Input current(A)	22	29	38.1	14	16.7	18
Power capacitance(KVA)	4.2	6.4	9.2	9.2	11	11.8
Output current range(A)	50-160	50-200	50-250	50-250	50-300	50-315
Output voltage(VDC)	15-22	15-24	15-26.5	15-26.5	15-29	15-29.7
Duty cycle	60%	60%	60%	60%	60%	60%
Power factor	0.85	0.85	0.85	0.85	0.85	0.85
Efficiency	85%	85%	85%	85%	85%	85%
Type of wire feeder	Embedded	Embedded	Embedded	Embedded	Embedded	Embedded
Post-flow time(s)	1	1	1	1	1	1
Diameter of the coil(mm)	200	270	270	270	270	270
Diameter of the wire(mm)	0.6/0.8	0.8/1.0	0.8/1.0	0.8/1.0	0.8/1.0	0.8/1.0
Size of the machine(mm)	480×240×360	520×260×430	530×270×440	530×270×440	530×270×440	530×270×440
Weight(Kg)	18	25	26	26	26	26
Thickness(mm)	0.8	0.8	0.8	0.8	0.8	0.8
Insulation class	F	F	F	F	F	F
Protection class	Ip23	Ip23	Ip23	Ip23	Ip23	Ip23

Circuit diagram

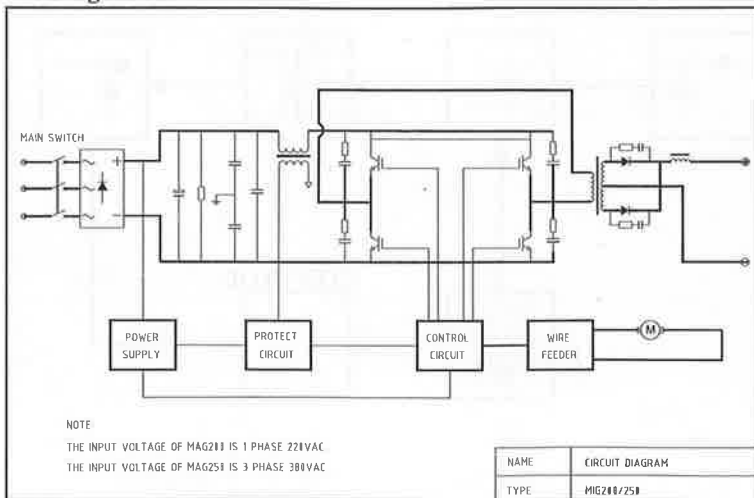

INSTALLTION & OPERATION

1. Connection of the input cable

- A primary power supply cable is available for this welding equipment. Connect the power supply cable with required voltage. MIG160/200 is of 1-phase 220VAC, while MIG250/300/315 is of 3-phase 380VAC.
- The primary wire should be connected to the corresponding socket to avoid oxidization.
- Use multi-meter to see whether the voltage value varies in the given range0.

2. Connection of output cable (according to the following drawing)

2a. Plug the fast connector, to the  on the panel board, and tighten it clockwise,

while the earth clamp at the other end is connected to the work piece.

For convenient welding operation, the cross section area of welding cable should be 35mm^2 , 50mm^2 , 70mm^2 in case of the maximum applicable current 170A, 250A, 450A. The increase of the cross section area of welding cable is necessary according to the current density. The recommended ratio of amperage and cross section area of lead is $5\text{A}/\text{mm}^2$.

2b. Connect the fast connector of the torch to the  of on the panel board, and tighten it clockwise.

3. Installation of wire feeder

Please refer to following drawing for the cables connection. Install the wire feeder.

- Fix the wire reel to the rack axis on the wire feeder; make sure the hole of the wire reel matches well with the bolt on the rack axis.
- The wire should be unpacked in clockwise direction, and cut off the curved part, which are tied around the fixed hole.
- Unite the screw on the wire-pressing wheel, and make the wire into the glove of the wire feed wheel, press the wire tightly, but not too tight, and then thread the wire into the torch.
- Different wire to different gloves according to their diameter. Please refer to page 8 Speed-read table.
- Press the wire feeding button to feed the wire out of the welding gun.

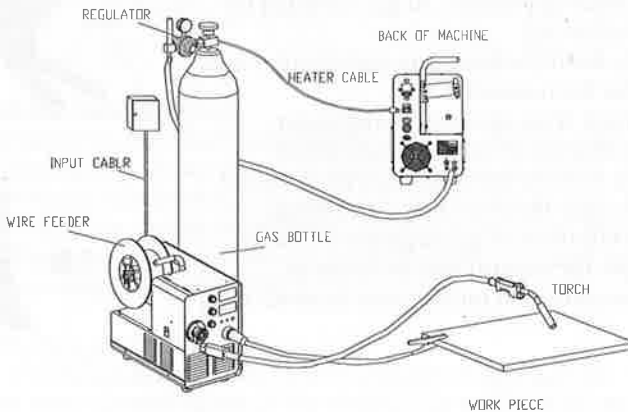

4. Panel description (see the following drawing)

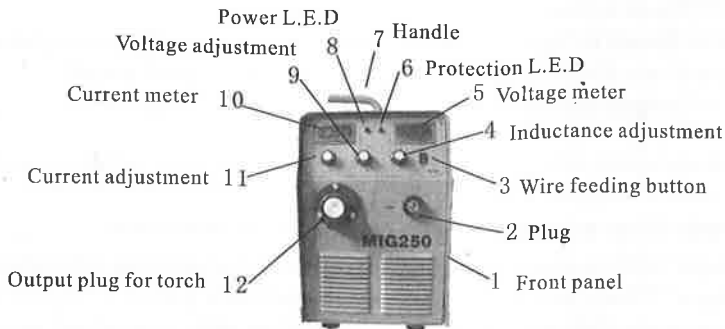

Connection of Shielding Gas

Connect the CO₂ tube, which come from the wire-feeder to the copper nozzle of gas bottle. The gas supply system includes the gas bottle, the air regulator and the gas hose, the heater cable which plug should be insert into the socket of machine's back, and use the hose clamp to Tighten it to prevent leaking or air-in, so that the welding point is protected.

Please note:

Leakage of shielding gas affects the performance of arc welding.

Avoid the sun shining on the gas cylinder to eliminate the possible explosion of gas cylinder due to the increasing pressure of gas resulted by heating of sun shining.

It is extremely forbid to knock at gas cylinder and lay the cylinder horizontally.

Ensure no person is up against the regulator, before the gas release or shut the gas output.

The gas output volume meter should be installed vertically to ensure the precisely measuring.

Before the installation of gas regulator, release and shut the gas for several time in order to remove the possible dust on the sieve to avail the gas output.

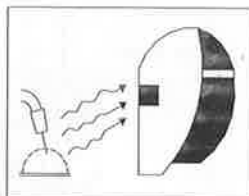
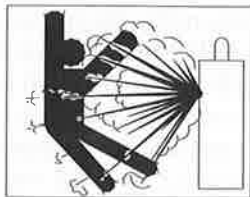

OPERATION

-Operation steps

- Turn on the air switch of the welding machine, open the gas cylinder valve, and adjust the flow meter to the desired position.
- Choose contact tip's aperture of the welding gun according to the diameter of the welding wire.
- Adjust the voltage adjustment knob and current adjustment knob to the desired position according to the thickness and craftwork of the work piece.
- Adjust the inductance adjustment knob to the desired position to get the right rigidity.
- Press the switch on the welding gun, then welding can be carried out.

-Set the welding current

-The option of the welding current and welding voltage directly influences the welding stability, welding quality and productivity. In order to obtain good weld, the welding current and welding voltage should be set optimally. Generally, the setting of weld condition should be according to the welding wire diameter, the melting form and the production requirement. Refer to the following figure to set the welding current, while refer to the speed-read table on page 8 to do the welding operation according to different working condition.

Range of welding current and voltage in short circuit transition and granular transaction.

Wire ϕ (mm)	Short circuit transition		Granular transition	
	Current (A)	Voltage (V)	Current (A)	Voltage (V)
0.6	40~70	17~19	160~400	25~38
0.8	60~100	18~19	200~500	26~40
1.0	80~120	18~21	200~600	27~40
1.2	100~150	19~23	300~700	28~42
1.6	140~200	20~24	500~800	32~44

-The option of the welding speed

The welding quality and productivity should be taken into consideration for the option of welding speed. In case that the welding speed increases, it weakens the protection efficiency and quickens the cooling. As a consequence, it is not optimal for the seaming. In the event that the speed is too slow, the work piece will be easily damaged, and the seaming is not ideal. In practical operation, the welding speed should not exceed 30m/h.

-The length of wire stretching out

The length of wire stretching out the nozzle should be appropriate. The increase of the length of wire stretching out of the nozzle can improve the productivity,

but if it is too long, excessive spatter presents in the welding process. Generally, the length of wire stretching out the nozzle should be 10 times as the welding wire diameter.

-The setting of the C0, flow volume

The protection efficiency is the primary consideration. Besides, inner-angle welding has better protection efficiency than external-angel welding. For the main parameter, refer to the following figure.

-The setting of the C0, flow volume

The protection efficiency is the primary consideration. Besides, inner-angle welding has better protection efficiency than external-angel welding. For the main parameter, refer to the following figure.

Option of C0, flow volume

Welding mode	Thin wire C0, welding	Thick wire C0, welding	Thick wire, big current C0, welding
C0, (L/min)	5~15	15~25	25~50

SPEED-READ TABLE

The option of the welding current and welding voltage directly influences the welding stability, welding quality and productivity. In order to obtain the good weld, the welding current and welding voltage should be set optimally. Generally, the setting of weld condition should be according to the welding diameter and the melting form as well as the production requirement.

The following parameter is available for reference.

Parameter for butt-welding (Please refer to the following figure.)



Plate thickness t (mm)	Gap g (mm)	Wire ϕ (mm)	Welding current (A)	Welding voltage (V)	Welding speed (cm/min)	Gas volume (L/min)
0.8	0	0.8~0.9	60~70	16~16.5	50~60	10
1.0	0	0.8~0.9	75~85	17~17.5	50~60	10~15
1.2	0	1.0	70~80	17~18	45~55	10
1.6	0	1.0	80~100	18~19	45~55	10~15
2.0	0~0.5	1.0	100~110	19~20	40~55	10~15
2.3	0.5~1.0	1.0 or 1.2	110~130	19~20	50~55	10~15
3.2	1.0~1.2	1.0 or 1.2	130~150	19~21	40~50	10~15
4.5	1.2~1.5	1.2	150~170	21~23	40~50	10~15

Parameter for flat fillet welding (Please refer to the following figure.)

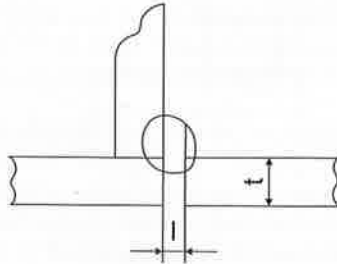

Plate thickness t (mm)	Corn size I (mm)	Wire ϕ (mm)	Welding current (A)	Welding voltage (V)	Welding speed (cm/min)	Gas volume (L/min)
1.0	2.5~3.0	0.8~0.9	70~80	17~18	50~60	10~15
1.2	2.5~3.0	1.0	70~100	18~19	50~60	10~15
1.6	2.5~3.0	1.0~1.2	90~120	18~20	50~60	10~15
2.0	3.0~3.5	1.0~1.2	100~130	19~20	50~60	10~20
2.3	2.5~3.0	1.0~1.2	120~140	19~21	50~60	10~20
3.2	3.0~4.0	1.0~1.2	130~170	19~21	45~55	10~20
4.5	4.0~4.5	1.2	190~230	22~24	45~55	10~20

Parameter for fillet welding in the vertical position (Please refer to the following figure.)

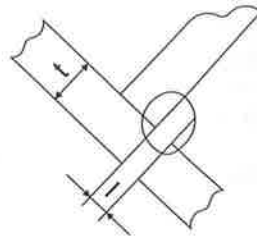

Plate thickness t (mm)	Corn size l (mm)	Wire ϕ (mm)	Welding current (A)	Welding voltage (V)	Welding speed (cm/min)	Gas volume (L/min)
1.2	2.5~3.0	1.0	70~100	18~19	50~60	10~15
1.6	2.5~3.0	1.0~1.2	90~120	18~20	50~60	10~15
2.0	3.0~3.5	1.0~1.2	100~130	19~20	50~60	10~20
2.3	3.0~3.5	1.0~1.2	120~140	19~21	50~60	10~20
3.2	3.0~4.0	1.0~1.2	130~170	22~22	45~55	10~20
4.5	4.0~4.5	1.2	200~250	23~26	45~55	10~20

4. Parameter for Lap Welding (Please refer to the following figure.)

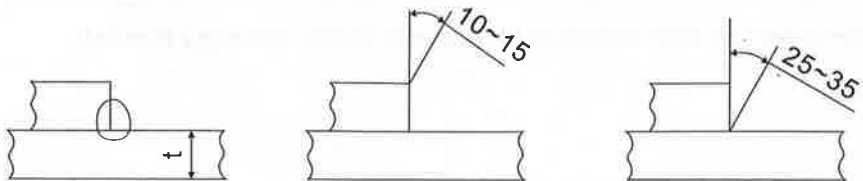

Plate thickness t (mm)	Welding position	Wire ϕ (mm)	Welding current (A)	Welding voltage (V)	Welding speed (cm/min)	Gas volume (L/min)
0.8	A	0.8~0.9	60~70	16~17	40~45	10~15
1.2	A	1.0	80~100	18~19	45~55	10~15
1.6	A	1.0~1.2	100~120	18~20	45~55	10~15
2.0	A or B	1.0~1.2	100~130	18~20	45~55	10~20
2.3	B	1.0~1.2	120~140	19~21	45~50	10~20
3.2	B	1.0~1.2	130~160	19~22	45~50	10~20
4.5	B	1.2	150~200	21~24	40~45	10~20

CAUTION

1. Working environment

- 1.1 The location in which this welding equipment is installed and operated should be of little dust, corrosive chemical gas, flammable gas or materials etc, and of maximum 90% humidity;
- 1.2 Avoid the operation of welding in the open air unless the working area sheltered from the sun shining, rain water and snow etc; the temperature of working environment should be maintained within -10C to +40C;
- 1.3 The minimum distance of this welding equipment and wall should be 30cm.
- 1.4 Keep the working environment in good ventilation.

2. Safety tips

Over-current/over-voltage/over-heating protection circuit is installed in this welding equipment. If the input voltage or the output current is too high or over heating generated inside this welding equipment, this welding equipment will stop automatically. However, excessive use (e.g. too high voltage) will still lead to machine damage, so please note:

2.1 Ventilation

High current passes when welding is carried out, thus natural ventilation cannot satisfy the welding equipment's cooling requirement. Maintain good ventilation of the louvers of this welding equipment. The minimum distance between this welding equipment and any other objects in or near the working area should be 30cm. Good ventilation is of critical importance for the normal performance and service life of this welding equipment.

2.2 Welding operation is forbid while this welding equipment is of over-load.

Remember to observe the max load current at any moment (refer to the optioned duty cycle). Make sure that the welding current should not exceed the max load current. Over-load current could obviously shorten the welding equipment's life, or even burn the equipment.

2.3 Over-voltage is forbid.

Regarding the power supply voltage range of the welding machine, please refer to "Main parameter" table. This welding equipment is of automatic voltage compensation, which enables the maintaining of the voltage range within the given range. In case that the input voltage exceeds the stipulated value, it would possibly damage the components of the welding equipment.

2.4 An earth terminal is available for this welding equipment. Connect it with the earth cable to avoid the static and electric shock.

2.5 A sudden halt may occur while the welding operation is carried out while this welding machine is of over-load status. Under this circumstance, it is unnecessary to restart this welding equipment. Keep the built-in fan working to bring down the temperature inside the welding equipment.

MAINTENANCE

1. Disconnect input plug or power before maintenance or repair on machine.
2. Be sure input ground wire is properly connect to a ground terminal.
3. Check whether the inner gas-electricity connection is well (esp. the plugs), and tighten the loose connection; if there is oxidization, remove it with sand paper and then re-connect.
4. Keep hands, hair, loose clothing, and tools away from live electrical parts such as fans, wires.
5. Clear the dust at regular intervals with clean and dry compressed air; if the working condition is with heavy smoke and air pollution, the welding machine should be cleaned daily.
6. The compressed air should be reduced to the required pressure lest the little parts in the welding machine be damaged.
7. To avoid water and rain, if there is, dry it in time, and check the insulation with mega-meter (including that between the connection and that between the case and the connection). Only when there is no abnormal phenomena can the welding continue.
8. If the machine is not used for a long time, put it into the original packing in dry condition.

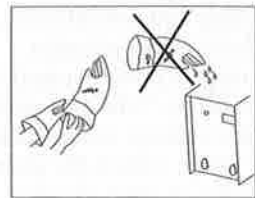
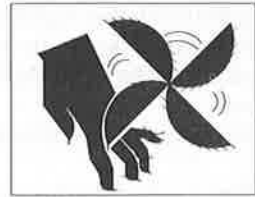
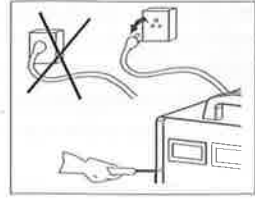

DAILY CHECKING

To make best use of the machine, daily checking is very important. During the daily checking, please check in the order of torch, wire-feeding vehicle, all kinds of PCB, the gas hole, and so on. Remove the dust or replace some parts if necessary. To maintain the purity of the machine, please use original welding parts.

Cautions: Only the qualified technicians are authorized to undertake the repair and check task of this welding equipment in case of machine fault.

1. Power sources

Part	Check	Remarks
Control panel	1.Operation, replacement and installation of Switch. 2.Switch on the power, and check if the power indicator is on.	
Fan	Check if the fan is functioning and the sound generated is normal.	If the fan doesn't work or the sound is abnormal, do inner check.
Power supply	Switch on the power supply, and check if abnormal vibration, heating of the case of this equipment, variation of colors of case or buzz presents.	
Other parts	Check if gas connection is available, case and other joints are in good connection.	

2. Welding torch

Part	Check	Remarks
Nozzle	1.Check if the nozzle is fixed firmly and distortion of the tip exists. 2.Check if there is spatter sticking on the nozzle.	1.Possible gas leakage occurs due to the unfixed nozzle. 2.Spatter possibly leads to the damage of torch. Use anti-spatter to eliminate the spatter.
Contact tip	1.Check if the contact tip is fixed firmly. 2.Check if the contact tip is physically complete.	Unfixed contract tip possibly leads to the damage of torch. The physically incomplete contact tip possibly leads to the unstable arc and arc automatically terminating.
Wire feeding tube	1.Measure length of wire feed tube stretching out. 2.Make sure that there is the agreement of wire and wire feed tube. 3.Make sure that there is no bending or elongation of wire feed tube. 4.Make sure that there is no dust or spatter accumulated inside the wire feed tube, which makes the wire feed tub blocked. 5.Check if the wire feed tube and O-shaped seal ring are physically complete.	1.The length of the wire feed tub stretching out should be long enough to contact the contact tip. 2.Replace it if less than 6mm, otherwise unstable arc possibly occurs. 3.Disagreement of the diameters of wire and wire feed tube possibly leads to the unstable arc. 4.Replace it/them if necessary. 5.Bending and elongation of wire feed tube possibly leads to the unstable wire feed and arc. 6.Replace it if necessary. If there is dust or spatter, remove it. 7.The Physically incomplete wire feed tube or O-shaped seal ring
Diffuser	Make sure that the diffuser of required specification is installed and is unblocked.	Defection weld or even the damage of torch occurs due to the non-installation of diffuser or the

3. Wire feeder

Part	Check	Remarks
Pressure adjusting handle	Check if the pressure-adjusting handle is fixed and adjusted to the desired position.	The unfixed pressure-adjusting handle leads to the unstable welding
Wire-feeding hose	1. Check if there is dust or spatter inside the hose or beside wire-feeding wheel. 2. Check if there is a diameter agreement of wire and wire-feeding hose. 3. Check if rod and wire feeding groove are concentric.	1. Remove the dust. 2. Non-agreement of the diameter of wire and wire-feeding hose possibly leads to the excessive spatter and unstable arc. 3. Unstable arc possibly occurs.
Wire-feeding wheel	1. Check if there is an agreement of wire diameter and wire-feeding wheel. 2. Check if the wire groove is blocked.	Non-agreement of wire diameter and wire-feeding wheel possibly leads to the excessive spatter and unstable
Pressure adjusting wheel	Check if the pressure adjusting wheel can rotate smoothly, and it's physically complete.	Unstable rotation or physically incompleteness of the wheel possibly leads to unstable wire feeding and arc.

4. Cables

Part	Check	Remarks
Torch cable	1. Check if the cable of torch is twisted. 2. Check if the coupling plug is in loose connection.	The twisted torch cable leads to unstable wire feeding and arc.
Output cable	1. Check if the cable is physically complete. 2. Check if insulation damage or loose connection exists.	possible electric shock.
Input cable	1. Check if the cable is physically complete. 2. Check if insulation damage or loose connection exists.	
Earth cable	1. Check if the earth cables are well fixed and not short-circuited. 2. Check if this welding equipment is well grounded.	Relevant measures should be taken to prevent the possible electric shock.