

REVISIONS

REV	DESCRIPTION	APPROVED	DATE
A	RELEASE FOR CUSTOMERS	MJEFFRIES	9/3/2021

1 Technical Bulletin#: TB-LD009 Revision Level: A

Title: Using Life Defender Gen 3 Tag Brackets

Purpose: 1) To show how a Tag Bracket is installed; and
2) To show how the Tag Bracket Drill Jig is used.

Features of Gen 3 Tag Brackets:

- Gen 3 Tag Brackets now have over-molded ends that provide a soft and smooth area for the tag to be inserted through.
- The "cabinet" bracket is the same except for the now over-molded cover.
- The Slider handle now has its own bracket that gets attached to the handle with rivets.
- A properly applied security tag will prevent the "sliding AND the "secure"

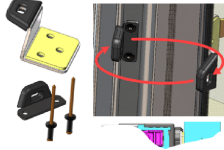

REFERENCE AUSTIN TECHNICAL BULLETIN TB-LD005 FOR INSTALLATION HELP

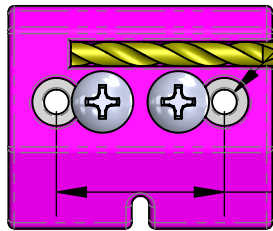
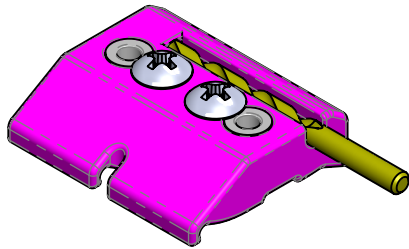

$([3.26] \text{ } \phi .1285 \text{ } 2X)$

$([22.23] \text{ } .875)$

**CF-JIG-TBG3-128
(DRILL JIG FOR HANDLE BRACKET)
SOLD INDIVIDUALLY**

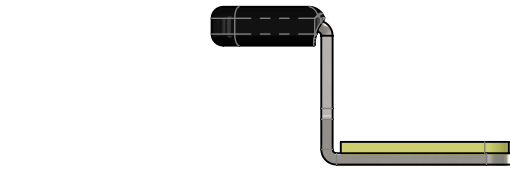

$([3.8] \text{ } .15)$

$([7.9] \text{ } .31)$

USE #6 FLAT HEAD SCREWS
3x

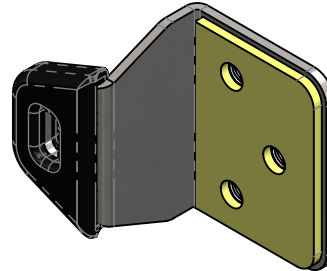
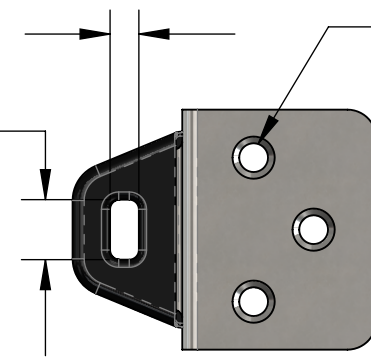

**CF-TAGBRACKET-A05
(CABINET TAG BRACKET)
SOLD INDIVIDUALLY IN BULK**

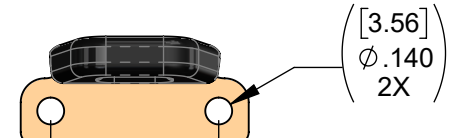

$([3.56] \text{ } \phi .140 \text{ } 2X)$

$([22.23] \text{ } .875)$

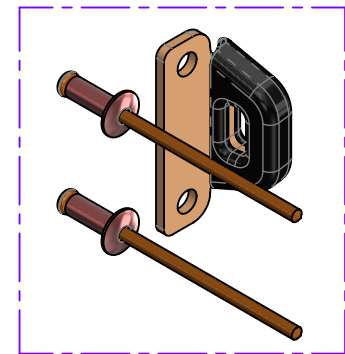
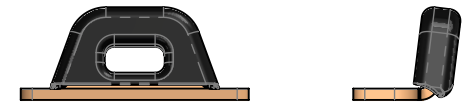

**CF-TAGBRACKET-A06KIT
(HANDLE TAG BRACKET)
SOLD AS A KIT - BRACKET AND TWO BLACK PAINTED RIVETS**

3. REFERENCE AUSTIN TECHNICAL BULLETIN TB-LD009 FOR INSTALLATION INSTRUCTIONS.
2. THIS IS A CUSTOMER REFERENCE DRAWING TO IDENTIFY PARTS.
1. THIS DRAWING IS ASSOCIATED WITH THE MODEL FILE OF THE SAME FILE NAME AND DEFINES IMPORTANT CHARACTERISTICS. UNSPECIFIED DIMENSIONAL CHARACTERISTICS MUST MATCH SOLID MODEL TO WITHIN +/- .020" [0.5MM], OR +/-2% FOR CHARACTERISTICS OVER 1" [25MM].

NOTES

INFORMATION ON THIS DRAWING BELONGS TO AUSTIN HARDWARE AND MAY NOT BE REPRODUCED OR DISTRIBUTED WITHOUT PERMISSION.

BY: MJeffries	DATE: 09-03-2021	WEIGHT: 0.021 LBS. (REF)	
DIMENSIONS: INCHES [METRIC] ANGULAR: 0 PL: +/- 5° 1 PL: +/- 1° LINEAR: 1 PL: +/- 0.040" [1.00] 2 PL: +/- 0.020" [0.50] 3 PL: +/- 0.010" [0.25]		FROM CONFIGURATION:	
TOLERANCES UNLESS OTHERWISE NOTED		PROJECT: 2718.16 - GEN 3 - LIFE DEFENDER	SCALE: 1:1
THIRD ANGLE PROJECTION TEMPLATE: ISTD-A-2011		DO NOT SCALE DRAWING	
DESCRIPTION: GEN 3 TAG BRACKET FAMILY ITEMS			
SHEET: 1 OF 1	SIZE: A	DWG #:	REV: A
ZR-TB-FAMILY-CUSTOMER			