

PRELIMINARY: NOT FOR CONSTRUCTION

**ICON**  
 Shelter Systems Inc  
 DISTINCTIVE STEEL SHELTERS  
 WWW.ICONSHELTERS.COM  
 COPYRIGHT 2004, ICON SHELTER SYSTEMS, INC.  
 1455 LINCOLN AVE.  
 HOLLAND MI, 49423  
 616.396.0919  
 800.748.0985  
 616.396.0944 FX

Elevation

DRAWN BY:	RGB
DATE:	7/6/2021
PRELIMINARY ID:	71840
REVISION:	A
BUILDING TYPE:	MP17X138-14M
PROJECT NAME:	

SHEET  
 1.0

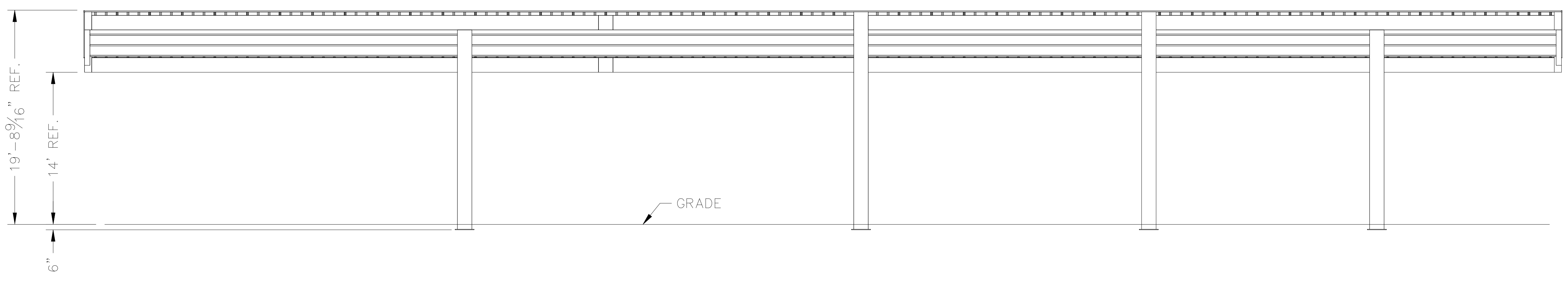

DWG:MP\17X136\M-P3-20-85-60\Drawings\Preliminary\MP17X136-14M-P3-20-85-60~71840.dwg

PRELIMINARY: NOT FOR CONSTRUCTION

**ICON**  
 Shelter Systems Inc  
 DISTINCTIVE STEEL SHELTERS  
 WWW.ICONSHELTERS.COM  
 COPYRIGHT 2004, ICON SHELTER SYSTEMS, INC.  
 1455 LINCOLN AVE.  
 HOLLAND MI, 49423  
 616.396.0919  
 800.748.0985  
 616.396.0944 FX

Anchor Bolt Layout

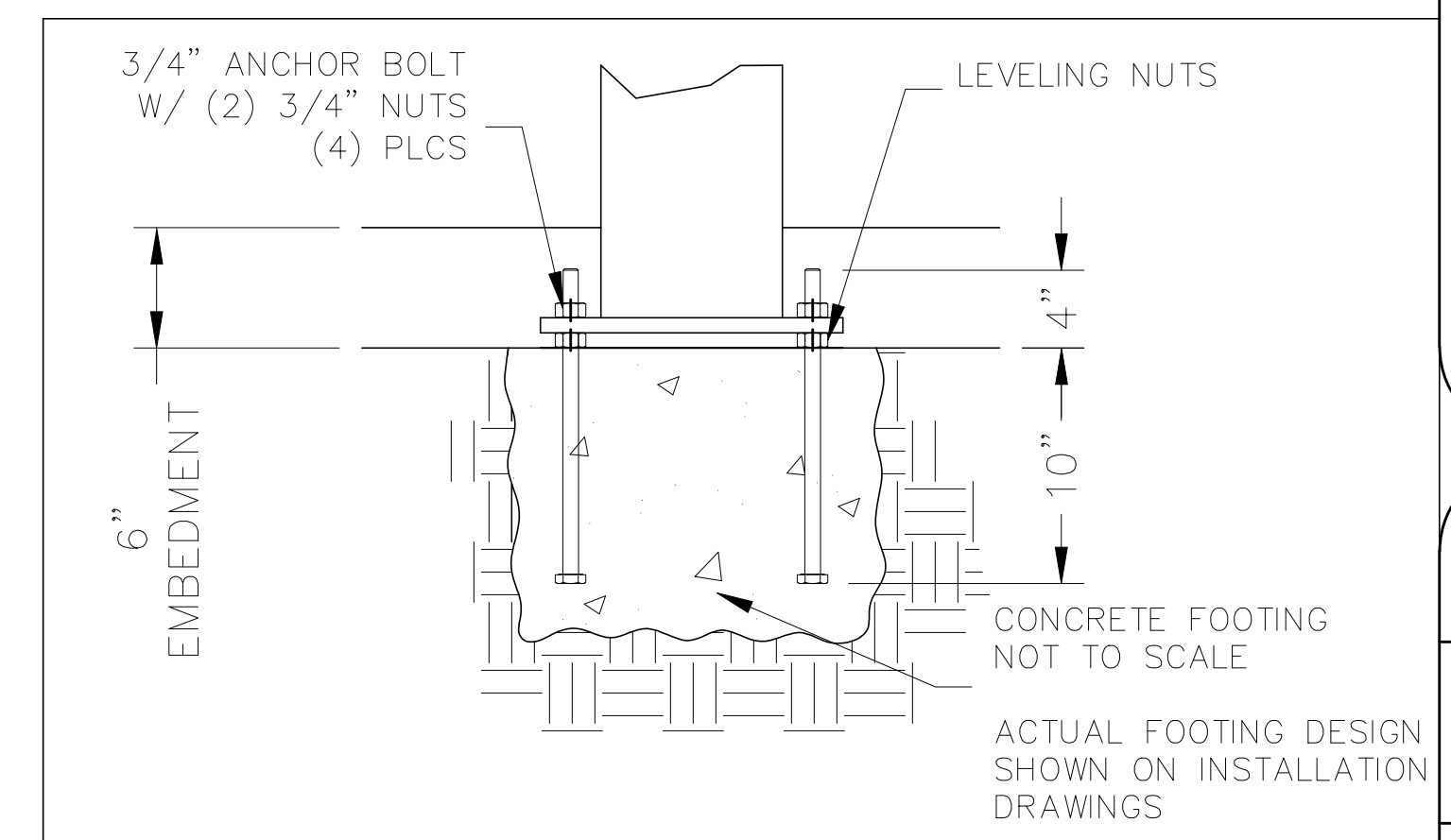
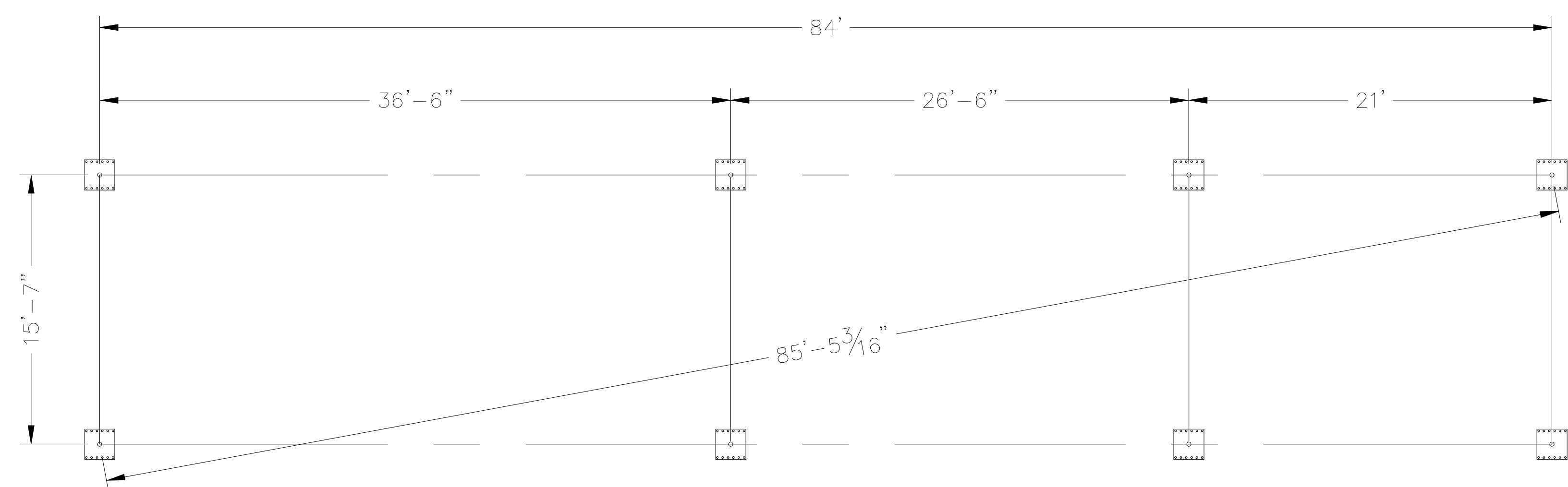

PRELIMINARY DRAWINGS SHOWN AS 6" BURIED  
 STANDARD BASE CONNECTION  
 COLUMN TYPE: A (6" BURIED)

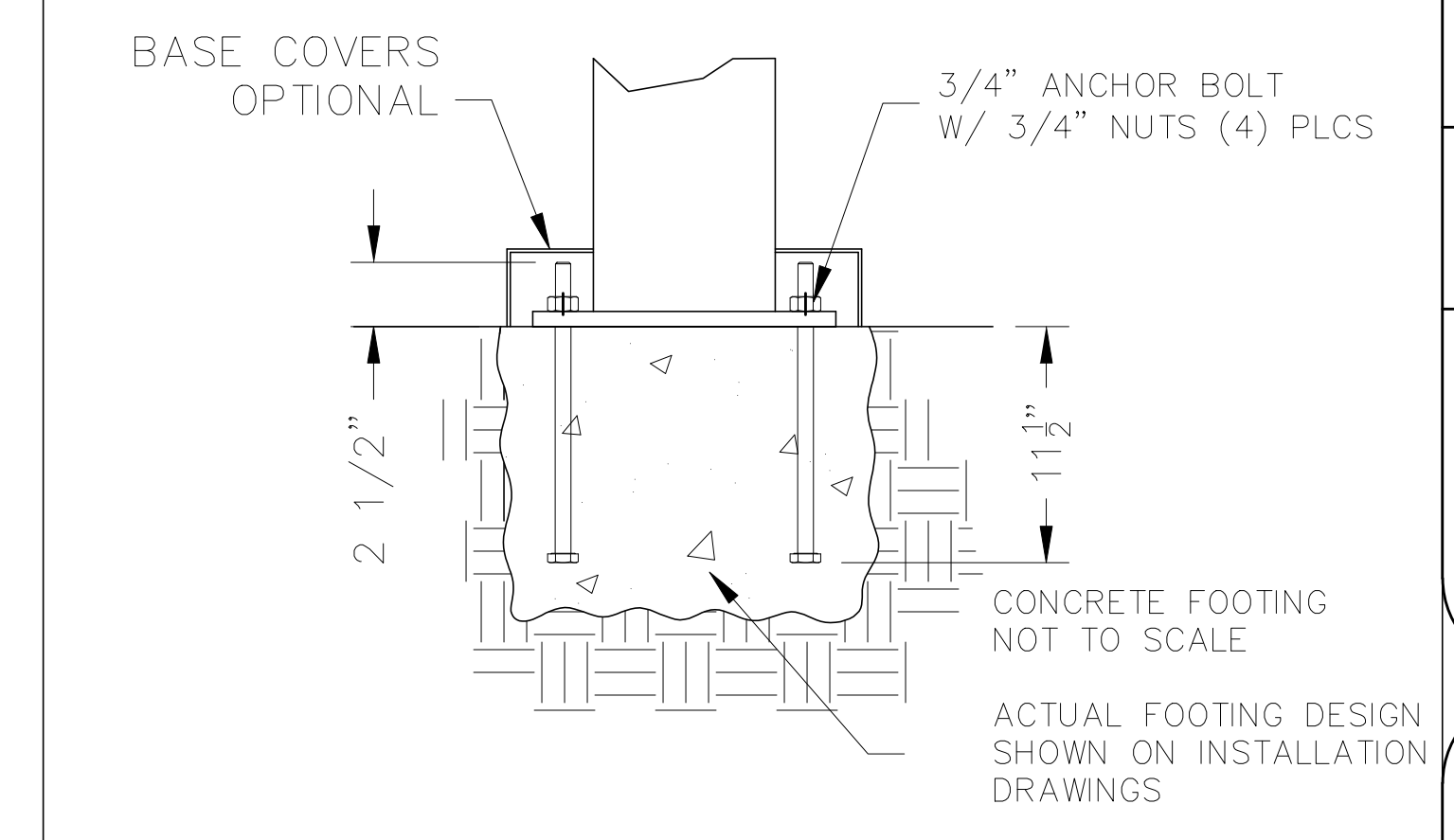

OPTIONAL BASE CONNECTION  
 COLUMN TYPE: B (SURFACE MOUNT W/ COVERS)

DRAWN BY:	RGB
DATE:	7/6/2021
PRELIMINARY ID:	71840
REVISION:	A
BUILDING TYPE:	MP17X138-14M
PROJECT NAME:	

SHEET  
 2.0

DWG:MP\17X136\M-P3-20-85-60\Drawings\Preliminary\MP17X136-14M-P3-20-85-60~71840.dwg

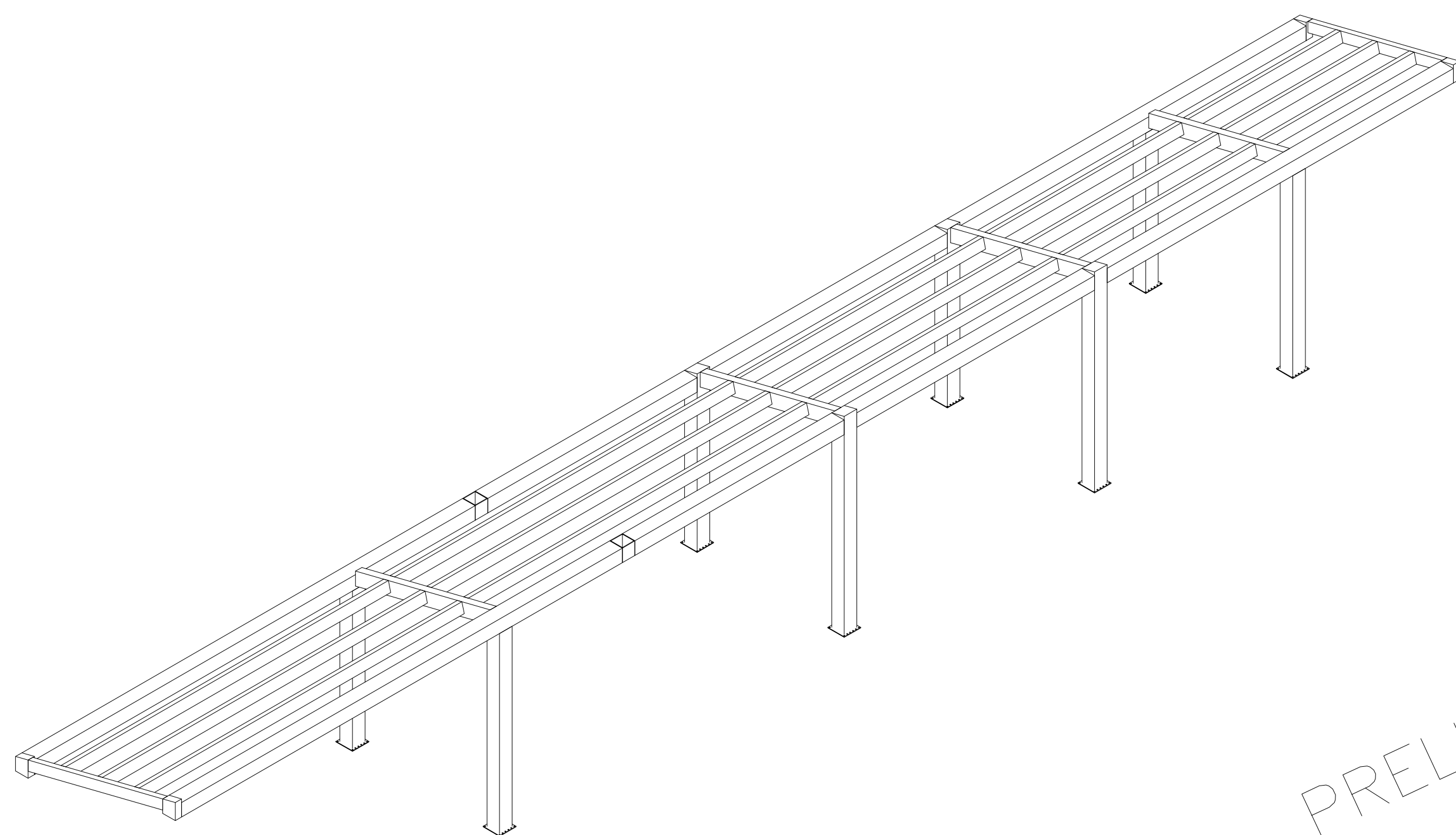
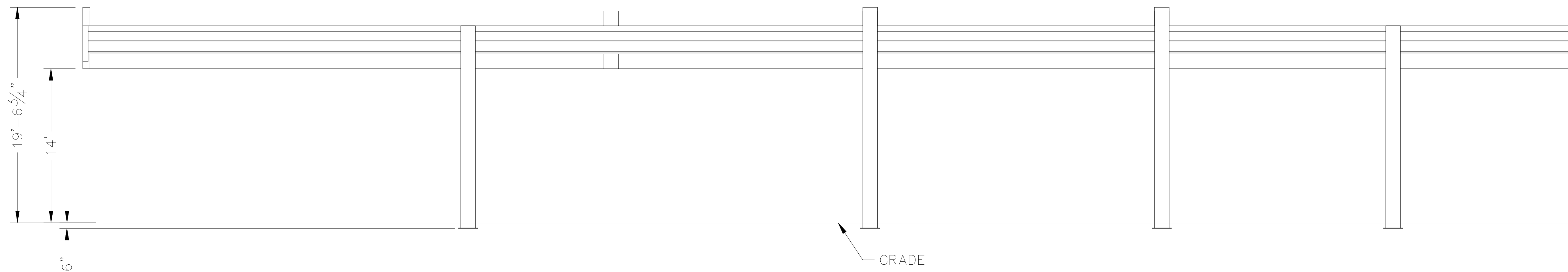
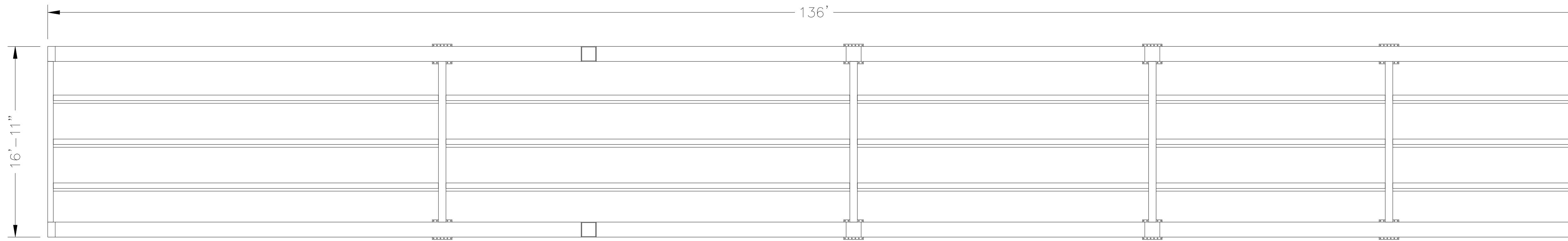

PRELIMINARY: NOT FOR CONSTRUCTION

ALL STRUCTURAL COMPONENTS WILL BE:  
 TUBE: ASTM A500 GRADE B  
 PLATE: ASTM A36  
 BOLTS: ASTM A325  
 NUTS: ASTM A563  
 WELDING: GMAW

NOTE:  
 COLUMN SIZE: HSS 16x16x5/8

**ICON**  
 Shelter Systems Inc  
 DISTINCTIVE STEEL SHELTERS  
 WWW.ICONSHELTERS.COM  
 COPYRIGHT 2004, ICON SHELTER SYSTEMS, INC.

1455 LINCOLN AVE.  
 HOLLAND MI, 49423

616.396.0919  
 800.748.0985  
 616.396.0944 FX

Frame

DRAWN BY:

RGB

DATE:

7/6/2021

PRELIMINARY ID:

71840

REVISION:

A

BUILDING TYPE:

MP17X138-14M

PROJECT NAME:

SHEET

3.0

Engineering\AcadStandard\Blocks\Title\CONCRETE19 QF-73-01-42

DWG:MP\17X136\M-P3-20-85-60\Drawings\Preliminary\MP17X136-14M-P3-20-85-60~71840.dwg

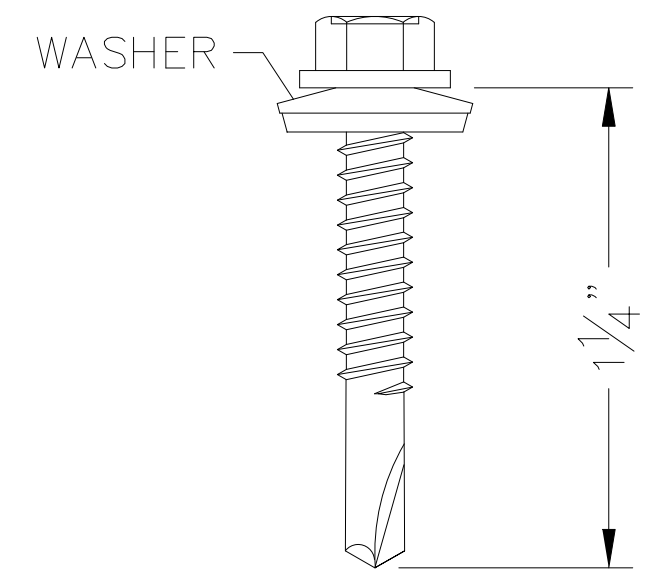

1 1/4" PAINTED SCREW

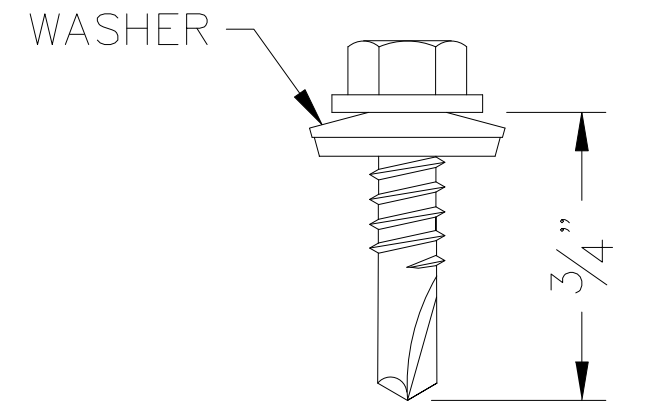

3/4" PAINTED SCREW

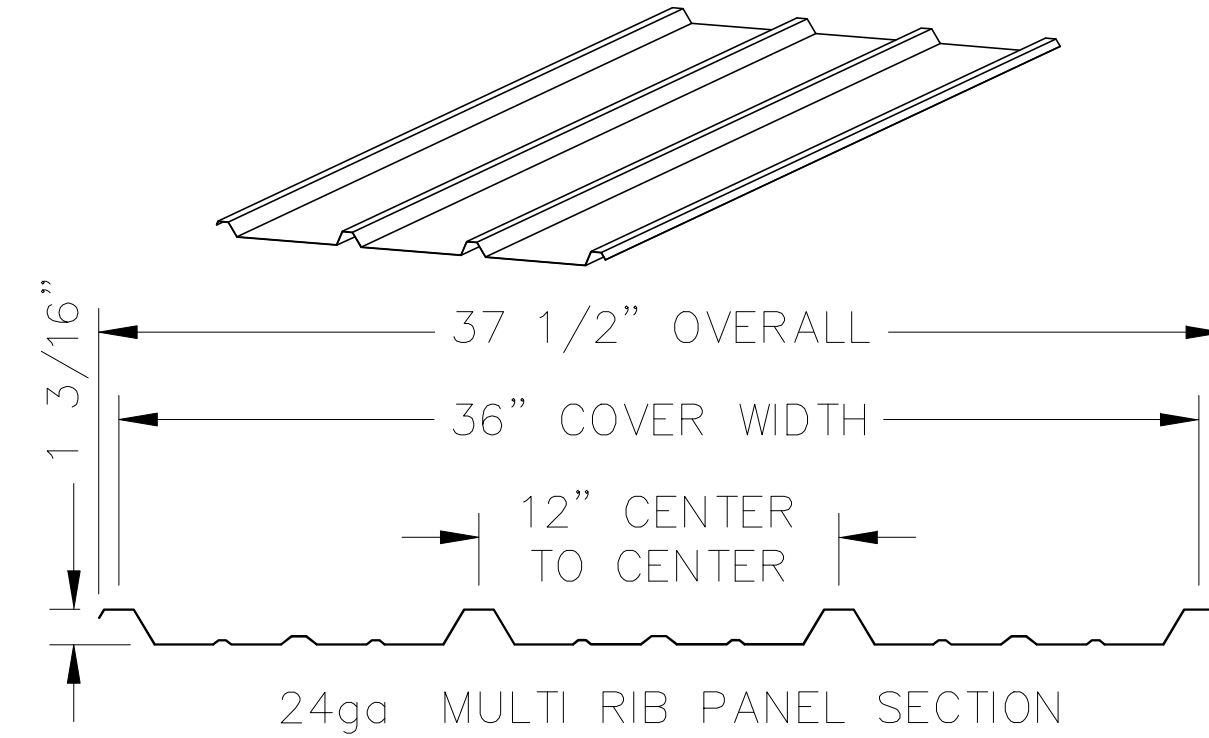

PRELIMINARY: NOT FOR CONSTRUCTION

**ICON**  
Shelter Systems Inc  
DISTINCTIVE STEEL SHELTERS  
WWW.ICONSHELTERS.COM  
COPYRIGHT 2004, ICON SHELTER SYSTEMS, INC.  
1455 LINCOLN AVE.  
HOLLAND MI, 49423  
616.396.0919  
800.748.0985  
616.396.0944 FX

Roof Layout

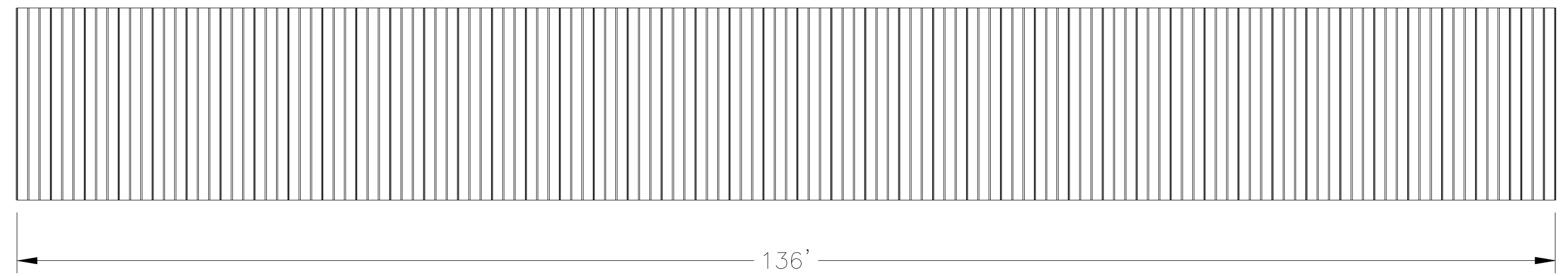
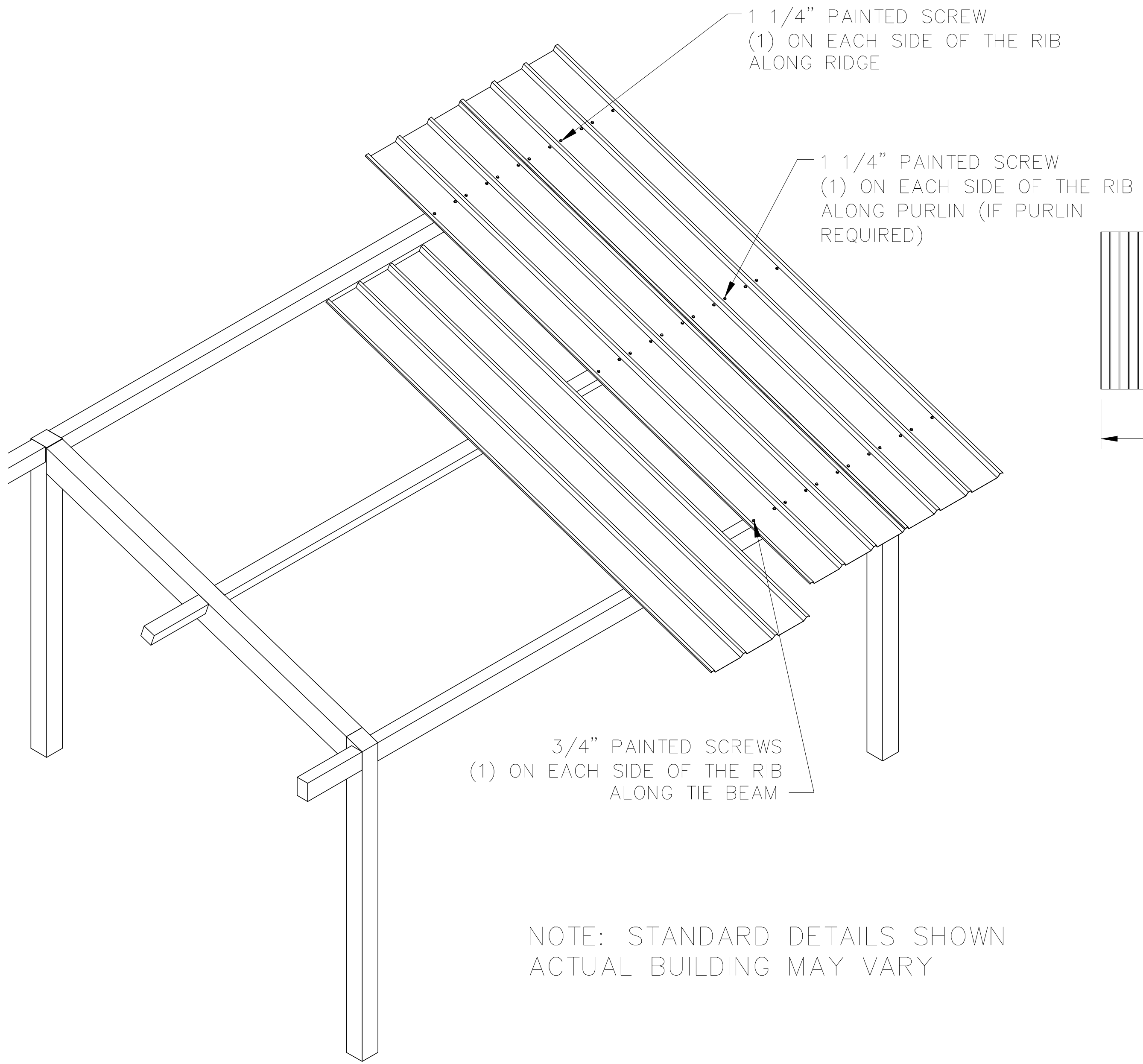

NOTE: STANDARD DETAILS SHOWN  
ACTUAL BUILDING MAY VARY

DRAWN BY:	RGB
DATE:	7/6/2021
PRELIMINARY ID:	71840
REVISION:	A
BUILDING TYPE:	MP17X138-14M
PROJECT NAME:	

DWG:MP\17X136\M-P3-20-85-60\Drawings\Preliminary\MP17X136-14M-P3-20-85-60~71840.dwg

# ELECTRICAL INFORMATION - MONOSLOPE

ICON'S STANDARD ELECTRICAL IS DESIGNED TO ACCOMMODATE Ø1/2" CONDUIT WITH A Ø3" INLET HOLE ON THE BOTTOM OF EACH COLUMN. THE CONDUIT PATHWAY RUNS THROUGH THE COLUMN, RAFTER, AND RIDGE BEAM THROUGH ALL BOLTED CONNECTIONS AS SHOWN. IF YOU HAVE SPECIAL ELECTRICAL REQUIREMENTS, PLEASE OUTLINE ANY CHANGES BELOW AS DESCRIBED.

PLEASE NOTE: DESIGN LIMITATIONS ON HOLE/CUTOUT SIZES MAY APPLY. ICON WILL REACH OUT TO DISCUSS ANY SUCH LIMITATIONS AS NEEDED.

NOTE: ICON SHELTER FRAME IS NOT UL LISTED TO ACT AS A CONDUIT FOR ELECTRICAL WIRING. CONSULT LOCAL BUILDING CODES WHEN PLANNING YOUR ELECTRICAL SYSTEM.

## OPTIONAL EXIT HOLES

IF REQUIRED, EXIT HOLES FOR LIGHTING, ETC. CAN BE PLACED IN THE RAFTER AND/OR PURLIN. USE FRAME SHEET OF THIS PRELIMINARY TO SPECIFY REQUIRED EXIT HOLE LOCATIONS AND SIZE.

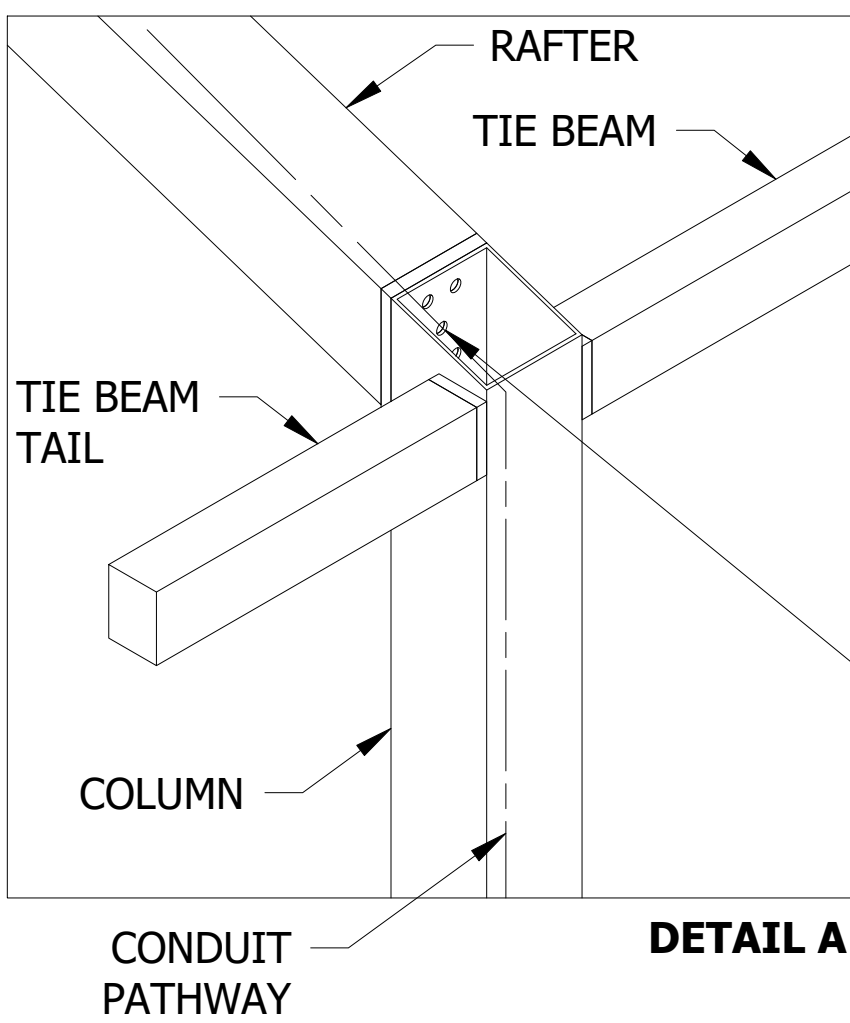
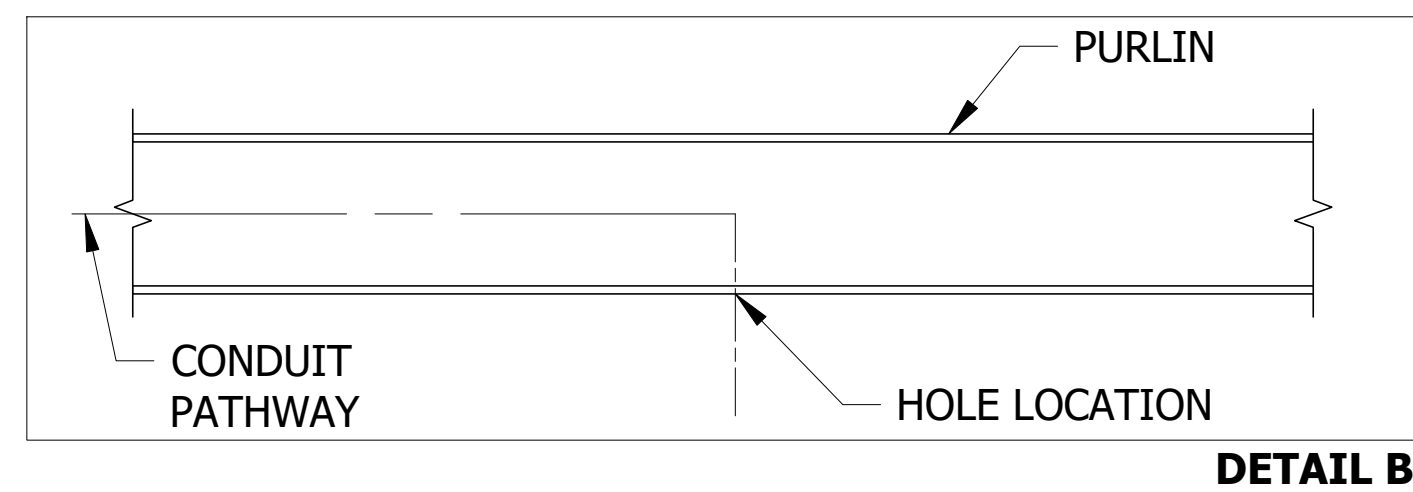

ICON PROVIDES A MINIMUM OF (1) 3/4" HOLE AT EACH CONNECTION FOR 1/2" CONDUIT. IF APPLICABLE, PLEASE SPECIFY REQUIRED CONDUIT SIZE: (CHARGES APPLY)

- 3/4" CONDUIT (1" HOLES)
- 1" CONDUIT (1 1/4" HOLES)
- OTHER (PLEASE SPECIFY)

NOTE: BUILDING DEPICTED ON THIS SHEET FOR ILLUSTRATION PURPOSES ONLY. ACTUAL LAYOUT AND FRAME MEMBER QUANTITIES VARY BY DESIGN. PLEASE REFER TO ELEVATION AND FRAME SHEETS IN THIS PRELIMINARY FOR ORDER-SPECIFIC CONFIGURATION.

PRELIMINARY: NOT FOR CONSTRUCTION

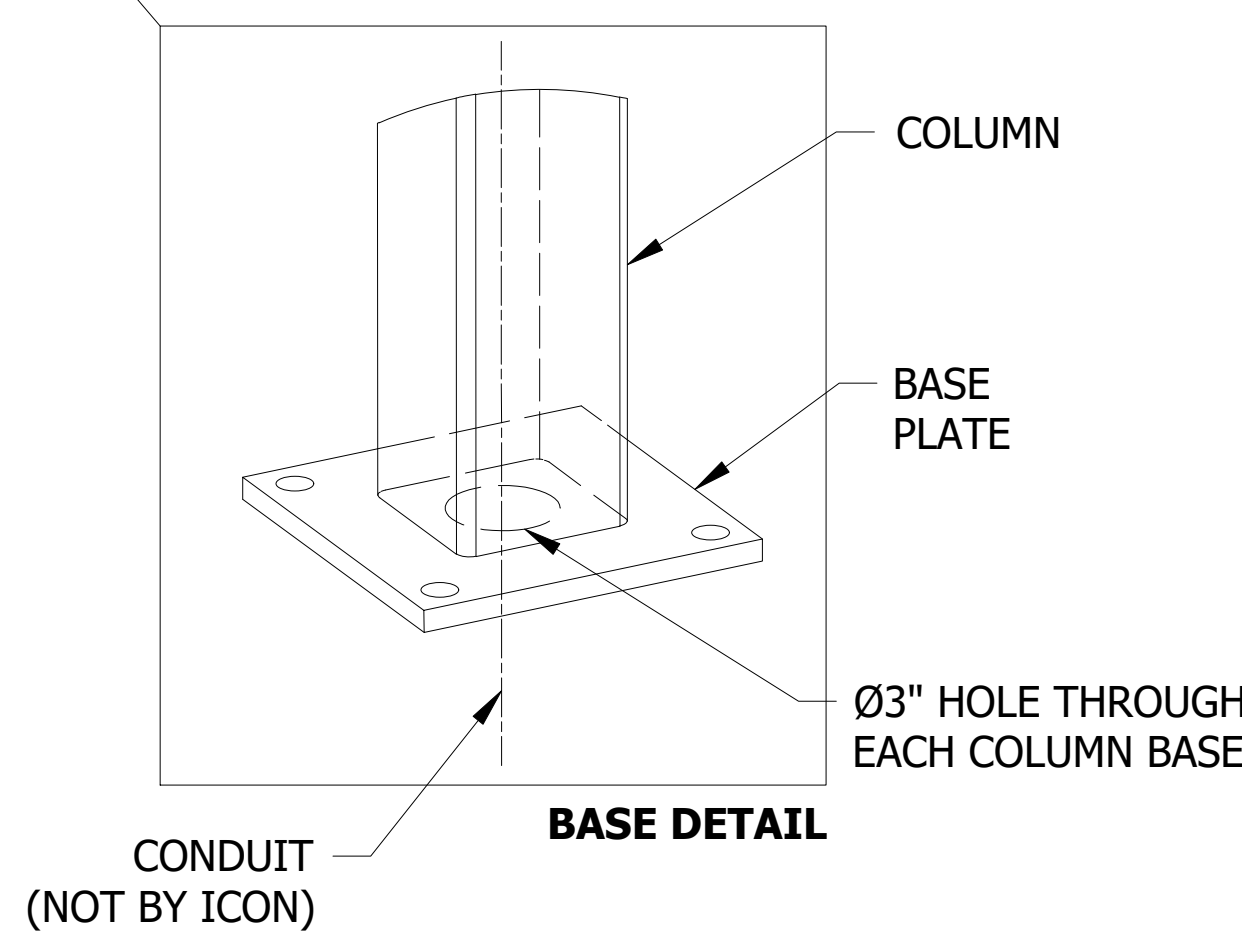
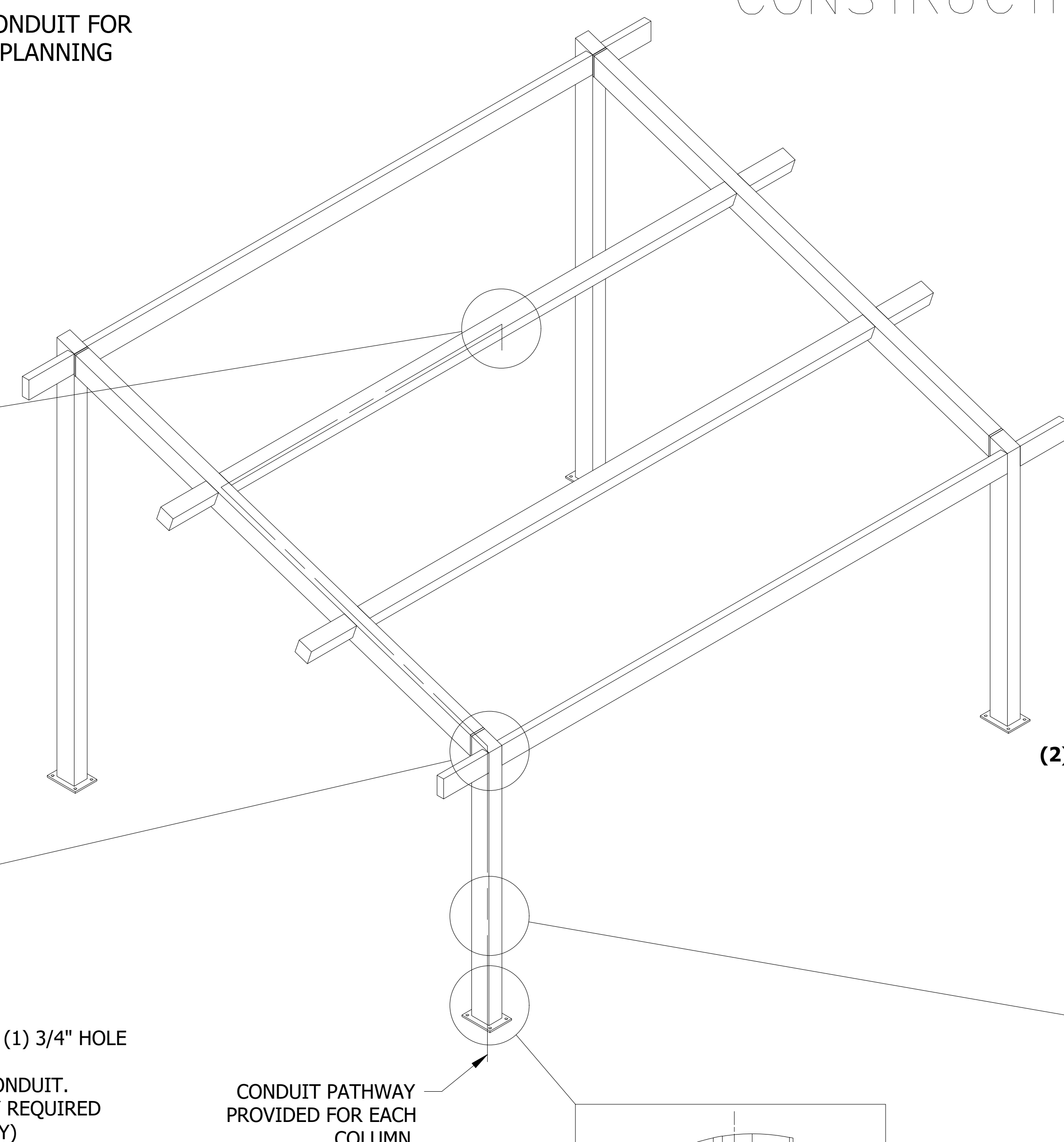

## STEPS:

1. CONDUIT HOLE SIZE (DETAIL A)
2. ELECTRICAL EXIT HOLES (DETAIL B)
3. ELECTRICAL ACCESS & COVER PLATES (DETAIL C)
4. ELECTRICAL CONDUIT PATHWAY (DETAIL D)

IF REQUIRED, PLEASE DRAW THE NECESSARY ELECTRICAL CONDUIT PATHWAY ON THE FRAME SHEET OF THIS PRELIMINARY.

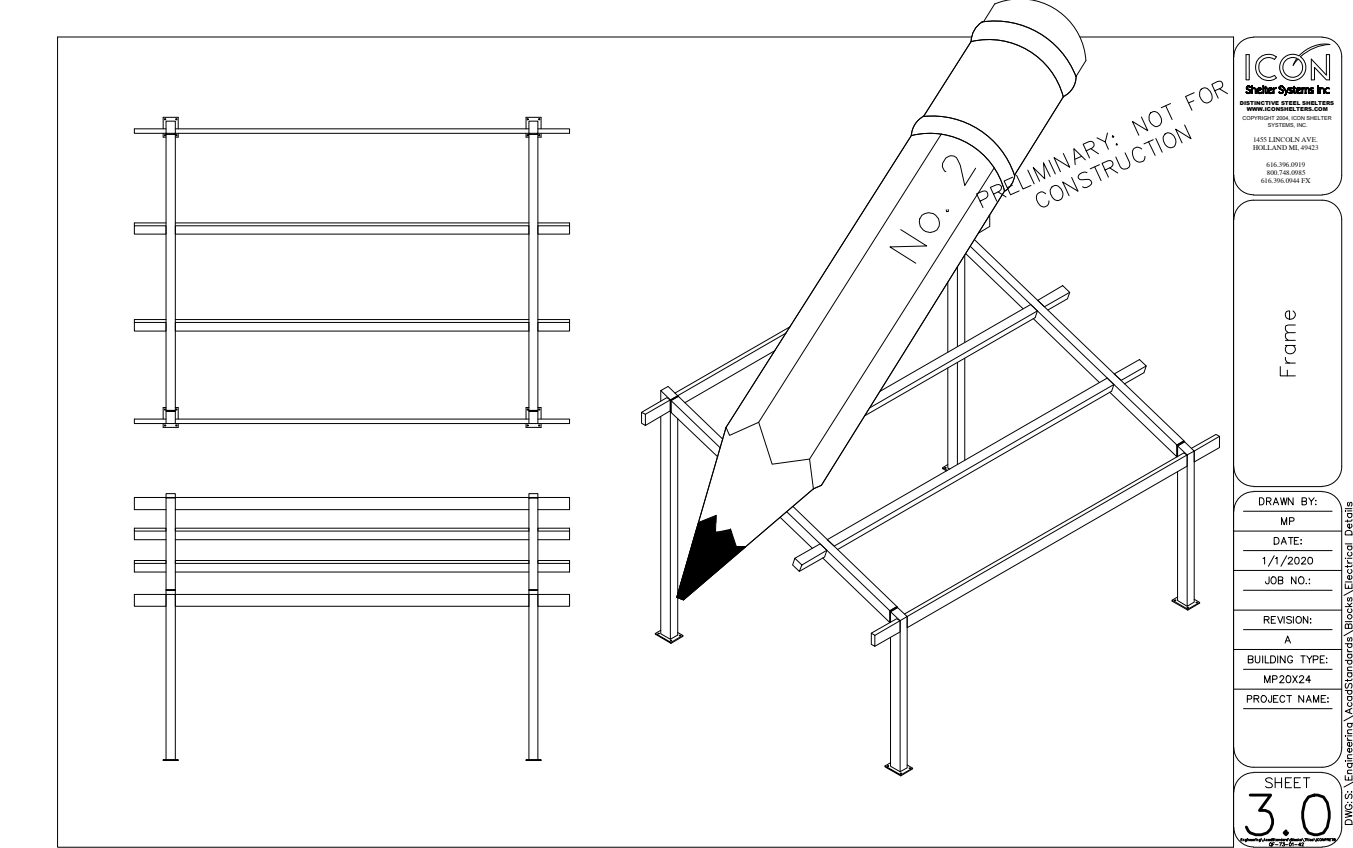

(1) STANDARD CUTOUT SIZE SHOWN. SPECIFY IF OTHER SIZE REQUIRED.

(2) CUTOUTS WILL BE ON INSIDE FACE OF COLUMN UNLESS OTHERWISE INDICATED ON FRAME SHEET.

(3) SPECIFY HEIGHT ABOVE FINISHED GRADE FOR EACH CUTOUT AS SHOWN

**OPTIONAL CUTOUTS**  
USE FRAME SHEET OF THIS PRELIMINARY TO SPECIFY REQUIRED CUTOUT LOCATIONS (CHARGES APPLY) SEE REQUIRED INFO BELOW

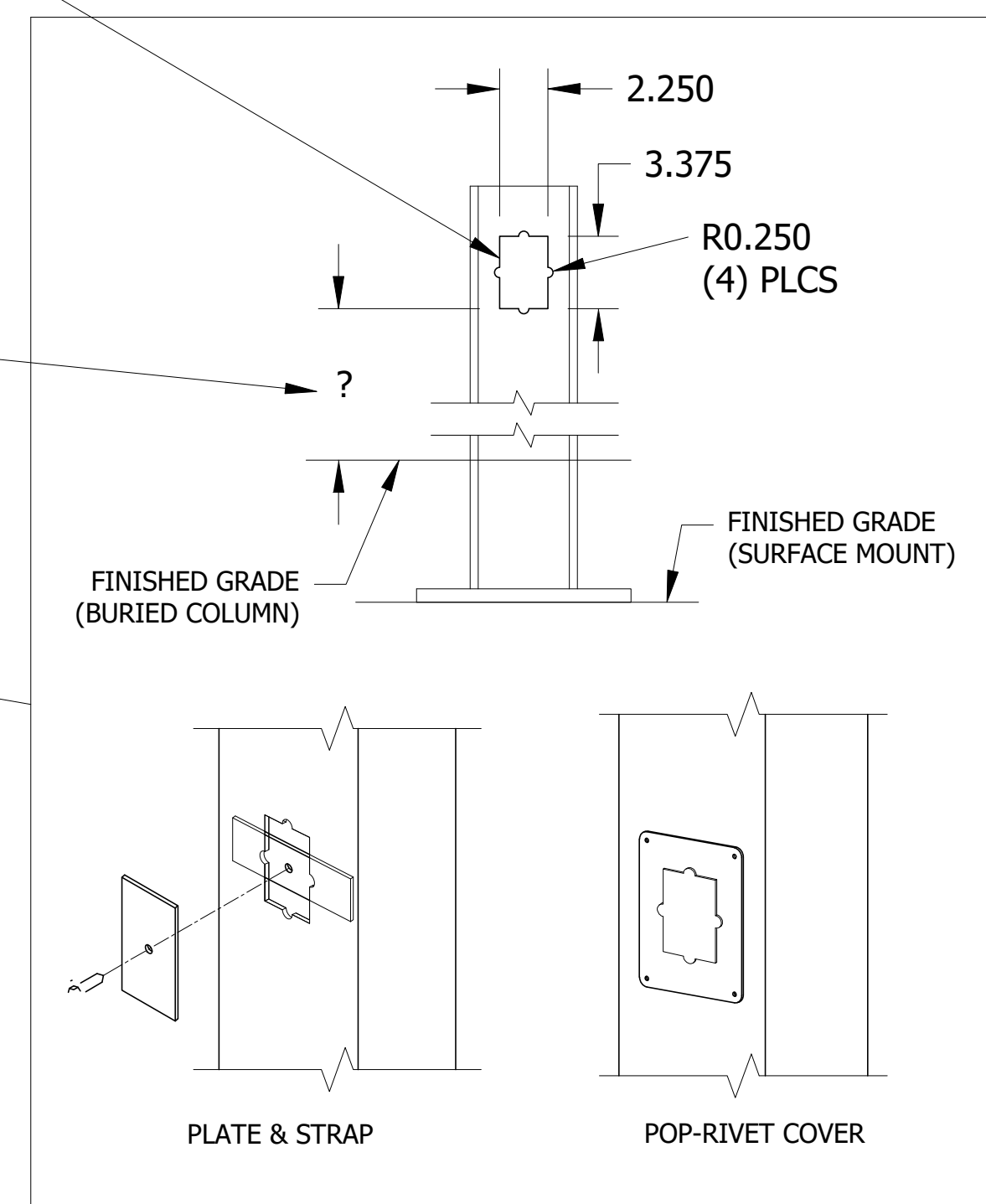

(4) COVER PLATES PROVIDED UPON REQUEST (CHARGES APPLY) PLEASE SPECIFY TYPE AND QUANTITY REQUIRED:

- PLATE & STRAP
  - POP-RIVET COVER PLATE
- HOW MANY REQUIRED? \_\_\_\_\_

**ICON**  
Shelter Systems Inc  
DISTINCTIVE STEEL SHELTERS  
WWW.ICONSHelters.COM  
COPYRIGHT 2004, ICON SHELTER SYSTEMS, INC.  
1455 LINCOLN AVE.  
HOLLAND MI, 49423  
616.396.0919  
800.748.0985  
616.396.0944 FX

Electrical

DRAWN BY:	RGB
DATE:	7/6/2021
PRELIMINARY ID:	71840
REVISION:	A
BUILDING TYPE:	MP17X138-14M
PROJECT NAME:	

SHEET  
**5.0**

DWG:MP\17X136\M-20-85-60\Drawings\Preliminary\MP17X136-14M-P3-20-85-60~71840.dwg