



PRODUCT CATALOG

2021



engcon[®]

Your convenience and safety is our standard

Remain seated while replacing your hydraulic tools

In 2019, we introduced EC-Oil automatic quick hitch as standard. EC-Oil provides added value to our customers, as they no longer have to leave the cab to change hydraulic tools. In addition, EC-Oil is also included as standard on all our hydraulic tools. Read more on EC-Oil on page 4.

Standardised lock enhances safety

In 2020 we introduced our next development, one standardized locking system so operators use the same control to operate our quick hitches. This system mean you always operate the quick hitch lock on the tiltrotator quick hitch with our intelligent control panel. Forget all those hidden switches that work differently depending on the type of machine you're operating. Now you always control the tiltrotator quick hitch lock in the same way regardless of machine make or model. Read more about OSC on page 22.

Hoseless – simple and easy to service

Not only do we raise the standard but we continue to improve our products at pace. In 2020 we also introduced our hoseless quick hitch for all tiltrotators with S45-S70 hitches. This means no more tangled hoses inside the cramped hitch. The only remaining hoses are those for the locking cylinder. You can add more EC-Oil blocks by bolting them in place without the need for hose routing.

Another unique feature enjoyed by our hoseless hitches is the ability to operate both with EC-Oil automatic oil connectors and 'regular' extra connections of type Tema or similar. This means you can use hydraulic tools with EC-Oil and those of your tools that still have regular hose connections. Read more about our hoseless hitch on page 8.

The above are just a few examples of why you should choose engcon, you simply get so much more!



engcon Environmental Certification
SS-EN ISO 14001:2004



engcon Quality Certification
SS-EN ISO 9001:2008

*engcon is not responsible for any printing errors.
The illustrations in the catalogue show typical configurations.
Technical data may vary. We reserve the right to make changes
without prior notice.*



CHANGE THE WORLD OF DIGGING



Contents

4	EC-Oil	
8	Hoseless modular system and high-flow swivel	
10	Profitable choices	
12	Tiltrotators	
20	Quick hitch	
22	Locking system	
24	Quick hitches	
25	Attachment brackets	
	GS40-ECO-GS80-ECO	25
	GS30-GS80	25
	S30	25
26	Detachable grab	
27	Detachable sweeper	
28	Integrated gripper	
29	Hydraulic tools	
	Stone and sorting grab	29
	Timber/combi grab	30
	Pallet forks	30
	Compactor	31
	Sweeper roller	32
34	Mechanical tools	
	Grading beam	32
	Deep-digging bucket	34
	Cable bucket	34
	Riddle bucket	35
	Grading bucket	36
	Water & sewerage bucket	36
	Gripper-adapted bucket series	36
	Tarmac Cutter	37
	Ripper	37
39	Optional extras	
	Joysticks	39
	Control system	40
	Sensors for machine control	41
42	Technical data	

Switch jobs in an instant

EC-Oil is the key to our system. It means you can quickly switch hydraulic tools from the cab or decouple the tiltrotator when you need more breakout force. Now EC-Oil automatic oil connection is our standard. In some jobs, this can save an hour or more every day compared to manual connection – and time is money...

As a supplier, we can help you with a complete solution with everything from control systems, hitches, and attachments and the means to connect them all. Use EC-Oil for fast tool changes directly from the cab. With EC-Oil on the excavator hitch on top of the tiltrotator, below the tiltrotator, and on the tool itself it is possible to switch from tiltrotator mounted hydraulic attachments such as grabs, compactors or tree shears to directly mounted tools such as a hammer within seconds at full machine pressure, without leaving the cab.

EC-Oil saves weight, which means fuel savings and better overall economy. This forms a system of tools which makes the job fast, efficient and profitable. EC-Oil is designed for high operational reliability in demanding environments. EC-Oil has no hoses or electrical cables that move when connected. This reduces the risk of pinch damage, wear and tear. engcon's quick-release systems are able to couple pressurized implements with full system pressure.

The self-developed oil and electrical connections are designed to better withstand the harsh conditions which are often common around an excavator. The connections are developed or tough times, proven through destructive testing at 1600 bar working pressure and field studies in dirty environments. With EC-Oil you also connect central lubrication automatically.

EC-Oil™



EC-Oil block with:

1. Electrical connector, 12 pin
2. Two oil connectors (supply and return)
3. Central lubrication

EC-Oil in a nutshell

- » EC-Oil is standard for simultaneous purchases of engcon's machine hitch, tiltrotator and control system
- » Lets you change hydraulic tools in just 10 seconds without leaving the cab
- » Connects hydraulic tools automatically
- » Can be retrofitted to all types of hydraulic tools, regardless of manufacturer *
- » Extremely durable connectors allow tool connection at full system pressure
- » Drip-free system = Lower environmental impact
- » Reduces problems with manual hydraulic couplings

* Check specifications and flow requirements

Calculate your savings

If nothing goes wrong, connecting a tool manually takes around 90 seconds. With Q-Safe and EC-Oil, the same tool change takes about 10 seconds. The number of times we switch tools naturally varies, but certain tasks require around 50 tool changes a day. On days like that, EC-Oil will save you more than one hour!

Automatic quick hitch system - our standard

When ordering engcon's machine hitch S40-S80, tiltrotator with control system at the same time EC-Oil comes as standard. On all engcon's hydraulic tools (S45-S80) always include EC-Oil.





EC-Oil with
case drain

engcon

engcon



engcon's automatic quick hitch

Connect without leaving the cab:

Use a quick hitch and the tiltrotator (1) or disconnect the tiltrotator and connect your tools directly into the machine's quick hitch when you need high breakout force or lifting capacity (2). All without leaving the cab!



EC-Oil™

engcon hydraulic tools



Rock and sorting grabs



Combi grabs



Ground compactors



Pallet forks



Sweepers

engcon Non-hydraulic tools

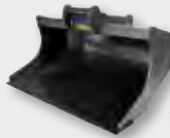

Grading bucket



Deep-digging bucket



Riddle bucket



Water and drainage bucket



Cable bucket



Ripper



Asphalt cutter



Grading beam

Adapt it for your existing tools



EC-Oil brackets



HOSELESS MODULAR SYSTEM AND HIGH-FLOW SWIVEL

Allow higher flows and make the tiltrotator lighter and easier to service

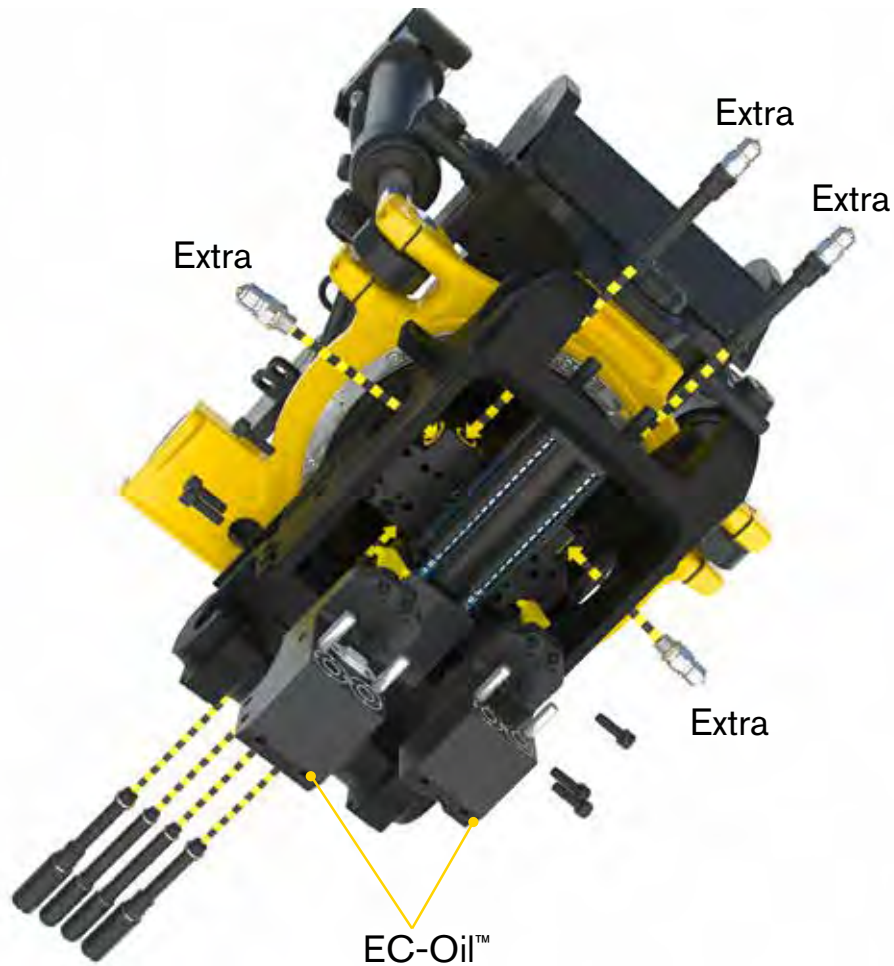

The hose-free design provides superb simplicity and an uncluttered quick hitch. Because the block is bolted on without the need for hoses, retrofitting engcon's EC-Oil automatic oil connection system is now simple. And it's just as easy to install and retrofit EC-Oil to engcon's new retrofittable, detachable grab cassette and rotating brush.

New high-flow swivel

In parallel with the creation of the new modular quick hitch, we have developed a new high-flow swivel that allows hydraulic flows up to 200 l/min. This is achieved by feeding the hydraulic functions directly without oil having to pass

through the tiltrotator's solenoid valves. The new high-flow swivel also has a separate case drain line, which allows oil to be drained via the tiltrotator. What's more, engcon's new swivel is built for pressures up to 350 bar.

Modular construction

This development is part of our unique modular approach in which we offer a basic product allowing our customers to easily add functions later without having to run hoses inside the cramped hitch. In addition, we minimize the problems with hoses that move in the quick hitch and which then risk being worn and can eventually leak.



PROFITABLE CHOICES

Build your own bespoke system with engcon



Standardised locking system

For safe quick hitch handling.



Joystick

Select now or add later (fits all makes and types of control systems).



Control system

Select now or add smartphone for remote support later.

engcon Positioning System

Select now or add later on models EC209, EC214, EC219, EC226 and EC233. Works independently of the machine's control system.



Quick hitch

Safety hitch beneath a tiltrotator, detachable grab and detachable sweeper.



Detachable grab



Detachable sweeper



EC-Oil

Automatic quick hitch for excavators

EC-Oil automatic oil, electrical and central lubrication connection is standard equipment on our automatic quick hitches.

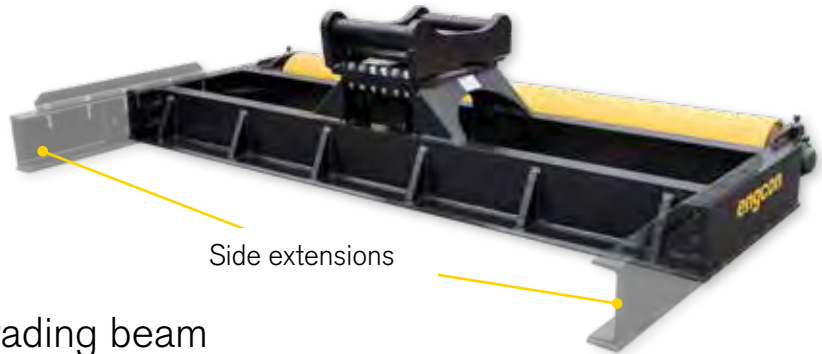

Side extensions

GRB | Grading beam

For levelling large areas.

EC-Oil | Rapid tool changes

EC-Oil automatic oil, electrical and central lubrication connection is standard equipment.



Read more on page 4

Bracket | Bolt-on

Compactors, sieve grabs, grading beams, timber/combi grabs, sweeper rollers – bolt-on bracket for easy hitch system replacement.



Tiltrotators

engcon's tiltrotators can be adapted to most excavator models and backhoe loaders on the market, from 1 tonne mini diggers right up to 33 tonnes.

Keeping your options open

engcon's tiltrotators are robustly built to a very high standard, and we provide the customer with many opportunities to select accessories right away or for retrofit. If you choose to retrofit, we've made it easy for you as in most cases it's just a matter of 'bolting on' the accessory later – whether it be one week or one year.

For example, all engcon S45-S80 standard hitches come ready for the detachable gripper and rotating brush. This means you can buy your tiltrotator without a gripper and retrofit one whenever it suits you. And there's no problem retrofitting your machine with an excavator guidance system; all of our tiltrotators from the EC209 and up come ready for installing the rotation sensor.

engcon tiltrotators come with the following as standard

- » EC-Oil automatic oil connection system is standard equipment on tiltrotators*
- » engcon's quick hitch as standard for increased safety (From EC206 and up)
- » Comes ready for detachable gripper
- » Comes ready for the sweeper
- » Prepared for engcon's standardized locking system to minimize the risk of incorrectly connected or dropped buckets
- » Comes ready for a rotation sensor for linking to the excavator guidance system (From EC209 and up)
- » Up to ± 45 -degree tilt angle for optimum digging
- » Powerful tilting torque for heavy-duty jobs
- » Flows of up to 120 l/min on extra hydraulic outlets (From EC214 and up)
- » Central lubrication
- » Load holding valves on the tilt cylinders for increased safety
- » Hardened piston rods
- » 2 years warranty

Control

- » Remote system support** with an app in your smartphone****
- » Up to 6 proportional functions***
- » Track/Wheel control**
- » TAB boom and other excavator functions
- » Palm rest on joysticks for higher comfort and best ergonomics

* Read more on page 4

** DC2

*** DC2 in combination with MIG2

**** Android



engcon provides a two-year warranty on all new tiltrotators. We also offer the opportunity to register your tiltrotator and log service carried out.



EC02B
1,5-2,5 t



EC204
2-4 t



EC206
4-6 t



EC209
6-9 t

Advantages of engcon's tiltrotators

- » Tilt cylinders equipped with load-holding check valves as standard equipment (requirement for operations with a pallet frame)
- » Protected hydraulic connections
- » Sealed hose protection prevents oil from spraying out sideways in the event of a hose break
- » Tilt angle up to 45 degrees
- » Robust upper sections
- » Robust upper tilt section with EC-Oil automatic oil, electrical, central lubrication connection. Applies from QS40 and up.
- » Comes ready for tilt-sensor for any excavation system**
- » Comes ready for Auto-Tilt***
- » Prepared to connect with any digging system ** (Applies from EC209 and up)
- » High tilt torque
- » High rotator torque
- » Robust cast frame
- » Low construction height
- » Hardened hydraulic piston rods
- » Comes with high-flow swivel with up to 120 l/min flow to extra hydraulics
- » Supplied as standard with the Q-Safe quick hitch on models from EC209. Select the optional EC-Oil for automatic hydraulic tool connection
- » Hydraulic motor on left side for best possible visibility
- » Tool holder S45-S80 is adapted as standard for retrofitting gripping cassettes or detachable sweepers
- » Adapted for engcon's proportional control systems and handles
- » All grease points routed to a single grease point. Easy to connect to the excavator's central lubrication system
- » Heavy-duty bearings for high service life
- » Robust lower sections
- » Engineered for high breakout torque
- » Unique design allows adjustment of lateral play without having to dismantle the tiltrotator = service friendly



- * Applies with selection of QS45 - QS80 upper tilt section
- ** Requires ePS and works with e.g. Leica Geosystems, Scanlaser, Topcon, Trimble, Novatron and MOBA (2017). Check compatibility with your excavator guidance system supplier.
- *** Check compatibility with your excavator guidance system supplier.



Stand for tiltrotator

With engcon's storage and transport stand, you can easily park, store and move your tiltrotator without risk of damage and dirt in the lower quick hitch. The stand is built in strong sheet metal and can be equipped with any attachment that is screwed into the chassis. The dimensions are like a Europall, 80 x 120 centimeters and the stand is designed for lifting with forks, both from the side and the gable.



EC214
9-14 t



EC219
14-19 t



EC226
19-26 t



EC233
24-33 t

SAVE MONEY, WORK MORE EFFICIENTLY

Applications for your tiltrotator

Pipelines, water mains and sewers

Digging ditches for water mains and sewers often involves working in confined spaces. In some cases, there's not even enough room to drive in or back out with the machine. The answer is an engcon tiltrotator – it will make your excavator more flexible than you ever could have dreamed of. A tiltrotator lets you dig at any angle, and you can excavate a manhole or a stop end without having to move the machine at all.

Construction sites

Not only does an engcon tiltrotator make excavation per se so much more efficient and profitable thanks to the ability to angle and rotate the bucket into positions that were previously impossible, but it also minimises the number of machine movements and thus enhances safety around the machine while reducing damage to the land.

Roadworks

Road construction involves many different tasks, and engcon's tiltrotators make work a lot simpler. When you're ditching, peeling away topsoil, terracing, laying pipes or working with grabs, there's no need to move the machine all the time.

Railway work

Working with excavators on railways demands extremely high standards. Safety always comes first, and this is where engcon provides important solutions. The use of an engcon tiltrotator transforms your excavator into a flexible, efficient and SAFE tool carrier.

Electrical work, telecoms and broadband

Excavation work in these areas is often associated with precision excavation in cramped locations and hard-to-get-at spaces. engcon tiltrotators are an elegant solution to such problems. Thanks to the ability to rotate and tilt the bucket, there's no need to constantly move the machine to gain access. It also makes digging up existing cables easy. Rotate the bucket through 90 degrees and then tilt it to a suitable angle to excavate alongside, below or above an existing cable with the highest precision.

Landscape gardening

No work demands as much precision and feel as landscape gardening. The land and local area must be shaped such that it blends into the surroundings. There are often no plans, so creating a beautiful, elegant landscape is an entirely up to you, your feeling and imagination.

THE BENEFITS OF A TILTROTATOR

- How to change the world of digging



Economy

Working with a Tiltrotator saves time, cuts the fuel consumption, reduces the need for manpower and the precision of the maneuvers makes you waste less material.



Safety

A tiltrotator also increases safety around the machine due to its high manoeuvrability and low space requirements. It significantly reduces the need for manual work, for instance the use of shovels and rakes.



engcon[®]



Flexibility

The tiltrotator easily tilts and rotates attachments as required, regardless of the machine's position. In addition to ordinary buckets, the machine can also be fitted with many different tools and replace many other machines at the same work site.



Environment

The reduced need to move the machine around means less damage to the ground, greatly reducing environmental impact by cutting fuel consumption. Since you can dig around obstacles and in narrow spaces, there's less need to move obstructing objects.



Comfort

With a tiltrotator and EC-Oil system, the operator retains control and comfort in the working environment since they don't need to leave the cabin to attach hydraulic tools.

Select gripper cassette or brush NOW or LATER

New quick hitch and smart accessories for more choice.

Have you ever bought a product and later regretted that you didn't buy that extra feature with its added benefits? Relax; engcon has solved the problem for you by making our Q-Safe quick hitches even smarter. S45-S80 quick hitch on the tiltrotator you can connect or remove your retrofit gripper cartridge or sweeper when you wish.

The technology means that engcon's tiltrotators with quick hitch S45-S80 have two powerful hooks in the front edge of the quick hitch, as well as space for extra hydraulics. It makes it possible to easily hang on engcon's retrofitable grab cassette or sweeper.

Gripper cassette

- Gripper Detachable Quick

The gripper cassette is simply hooked onto the quick hitch and locked into place at the same time as the hydraulic connection is made using a single action – a manoeuvre that takes less than a minute.

Gripper cassette

- Gripper Retrofit

The grip cassette is also available with manual connection of hydraulics and screwed into the quick hitch. This is not designed to be detachable, but is supplied as an aftermarket alternative to the factory-fitted integral gripper. Both versions are angled at 15 degrees for increased picking range.

Rotating brushes – Sweeper Detachable

Just like with the gripper cassette, the rotating brushes can be retrofitted simply on the quick hitch by being hooked onto the hitch's two mounting hooks. The rotating brushes are then locked and connected to the hydraulics in a single manoeuvre – quick and easy. The sweeper cassette is only available as a quick version and is driven by a powerful

hydraulic motor and is folded up or down with a hydraulic cylinder. The sweeper is extremely flexible in its design and its width can be adjusted to handle precisely the work it needs to do.

In its narrowest design, the sweeper can for example be adapted for cable sweeping, which facilitates excavation of existing cables or pipes – and most importantly, contributes to fewer cables or pipes being broken, since excavation is completed to a safe depth and then it sweeps down the rest. Thanks to our new rotating brushes, the need for manual labour is also minimised, which contributes to a safer work site. Safety is everything for us at engcon.

If you choose the wider version, you can in combination with its tiltrotator sweep gravel or soil into its own bucket, which simplifies the work of cleaning surfaces of materials ready to be taken away.

New level of Safety

In addition to giving the operator greater freedom of choice, we are also improving safety. The two sturdy hooks provide enhanced safety because they continue to hold the grab cassette or rotating brush in place; even if the lock function should fail, the centre of gravity of the gripper cassette or rotating brush's own weight will press it securely against the quick hitch.



Quick hitch

Strong suspensions and stable locking on engcon's quick hitch S45-S70 and location for extra hydraulics allows the use of additional hydraulic tools, such as engcon's new detachable grapple and sweeper.



Detachable gripper



Detachable sweeper





Cost-effective safety

Innovation and safety have always been a priority for engcon.

Above all in our product development. Today, we mark all our products with our own security marking Non Accident Generation – a safety guarantee for our customers. This means that as a customer, you know your choice of product adds up to a safer workplace and that the product meets the highest safety standards. Besides, we know that a safe workplace is a profitable workplace.

Welcome to the new and safe generation with engcon.

Below you see the symbol that marks the products we have developed specially for your safety.



Q-Safe™

AUTOMATIC QUICK HITCH WITH INCREASED SAFETY

Minimize the risk of dropped buckets

Dropped buckets and incorrect coupling of tools due to the "human factor" has been minimized. With engcon's quick hitch and standardized lock control on the excavator reduces that risk. With Q-Safe™ & QSC among other things, the bucket or selected tool must have ground contact with a certain pressure. It is almost impossible to loosen the bucket / tool hanging in the air, with engcon's secure quick hitch for excavators.

Check tool changes securely

Activate lock function*, lower the bucket/tool with a light ground pressure, loosens the bucket/tool. Then engcon's hitch loses contact with one of the axle bolts is blocked the turning function of the machine. Then both shoe shafts are complete disconnected, the swing lock can be lifted.

Connecting attachments

Activate the locking function*, hook on the bucket/tool and locks. When connecting the bucket/tool, lock again the pivot function when the first shaft reaches the bracket. When the bucket/the tool is properly locked, the swing lock can be lifted.

If the bucket/tool is not completely locked on both shoulders, the QSC alerts the environment and the driver using warning sounds and light signals. In addition, the swing lock is activated.

When the bucket/tool is completely and correctly connected warning sound/light goes out and the swing lock can now be lifted and the machine is ready for work with the bucket/tool safe and fully connected.

Read more about engcon's lock control on pages 22-23.

Warning system with light and audible signals is standard equipment**



The attachment must be in contact with the ground to be able to activate the quick hitch lock. ***

* Read more about standardized lock control on pages 22-23

** Read more about warning lights and sounds next to this

*** Ground pressure function means that the bucket / tool must have ground pressure to be able to be disconnected. The function is available in combination with engcon's locking system QSC (Quick hitch Standard Control)

Light Module



The rear pin lock also holds the front pin in its correct position, and thus minimizing the risk of accidents caused by swinging tools that are only connected to the front pin.

The hook is classified for safety in compliance with: EN ISO 12100-1/A1:2009 and EN ISO 12100-2/A1:2009

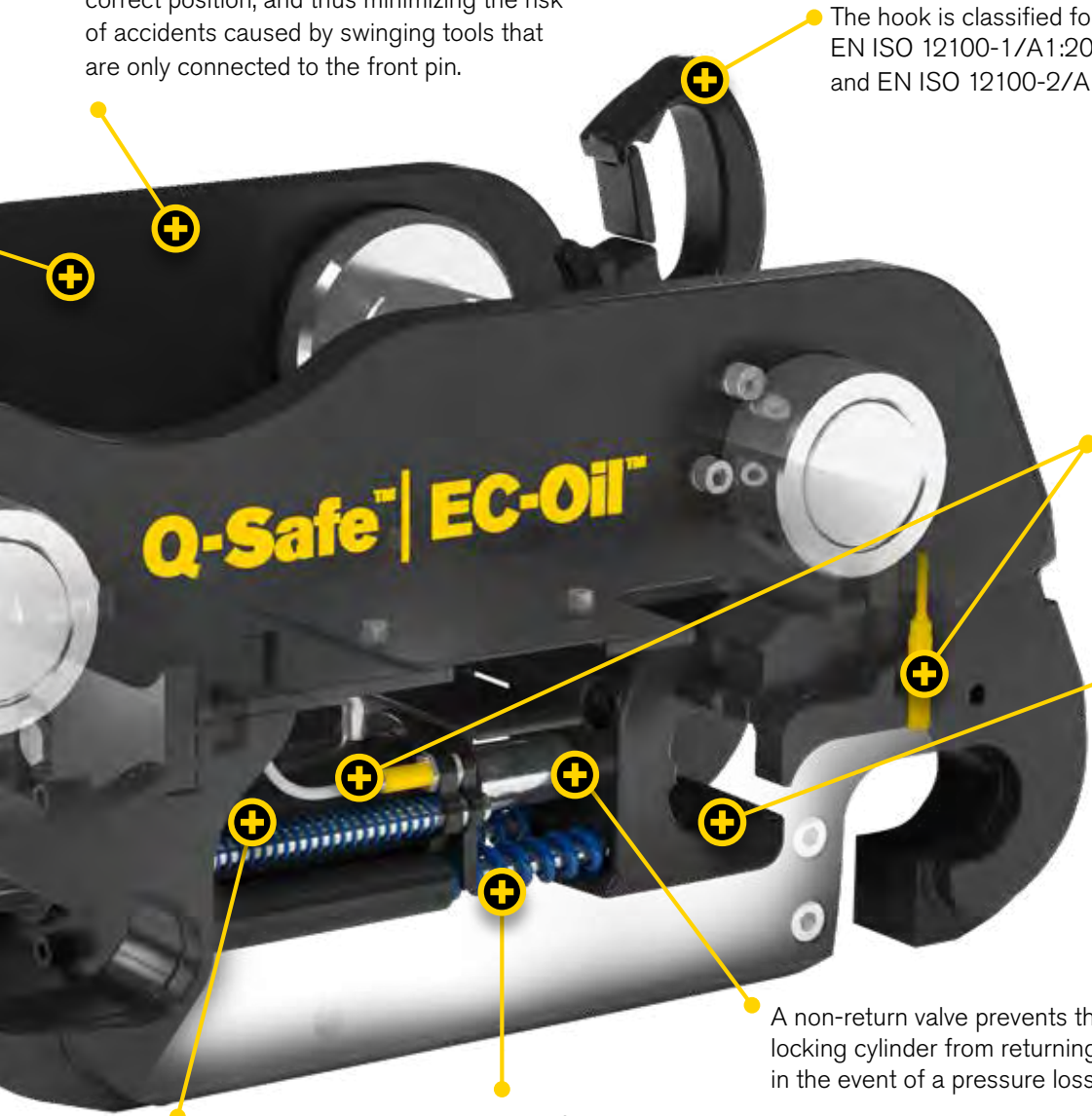

Double electronic sensors ensure contact with forward and rear axles.

The unique shape of the lock bolt retains the tool in the quick hitch even if other safety functions should fail.

A non-return valve prevents the locking cylinder from returning even in the event of a pressure loss.

Powerful springs maintain the lock even in the case of pressure loss.

engcon mounts are equipped as standard with EC-Oil, engcon's automatic hydraulic coupling system.

The combination of engcon's secure quick hitch and warning light/sound module warns both visually and audibly if both shafts are not in place and in locked mode.

The module is mounted on the left side of the excavator's stick and its wiring are integrated in the control system cabling. If a control system other than DC2 is used, this can be wired in separately cabling for the warning module to the excavator cab.

The complete system with swing limitation and ground contact to loosen gear is ordered in consultation with the respective machine supplier.

Locking system

Standardised hitch operation improves safety.

Today, there are about twenty major excavator manufacturers which all have a well-functioning system for maneuvering the quick hitch. However, the maneuvering differs as well positioning the locking buttons for the implement hitch between each machine manufacturer and model.

In cases where an excavator operator moves between different types of machines there is thus an obvious risk of incorrect handling. For example, it can be compared to having your pedals in your car the wrong way around depending on car brand. engcon's goal is to standardise the operation of all quick hitches for all excavators.

We have therefore developed a standardized locking system which minimizes the risk of pressing the wrong button or function. The locking system suits most excavators and attachments. The system consists of a control panel with a switch to activate the excavator's quick hitch and another to activate the machine hitch of the tiltrotator. All functions gathered in a panel that is always placed on the same place in the cab where it is easily recognized regardless the model or make of the excavator.

The locking system is part of our safety concept, "Non Accident Generation" where we create a standard for maneuvering hitches. A driver who changes from one excavator to another should easily be able to change buckets and attachments the safe way to reduce the risk of accidents.

The tool locking system can also control most brands of quick hitches, it helps to improve the function of the fully hydraulic hitches. With engcon's locking system, the tool holder can be selected regardless of make or model, another one unique safety feature that makes the bucket require ground pressure to detach, this means we have made dropping a bucket almost impossible which reduces the risk of accidents



Locking function for machine hitch

Slew lock deactivation

The combination of engcon's locking system and quick hitch further increases safety through a visual and audible warning system. The system warns with sound and light if both bucket axels are not in the right position. It is also possible to specify boom and slew lock when the hitch is in a unsafe state as an optional extra.

” The first purpose-designed combined quick hitch controller for twin-hitch arrangements.

With the combination of engcon quick hitch and locking system offers engcon one of the world's safest system for operating quick hitches. It does that by the driver always knowing what is happening and when it happens.



New standard for quick hitch locks under the tiltrotator!

engcon's smart and secure locking systems are standard on engcon's tiltrotators.

- + Standardises operation – regardless of excavator make and model
- + Lock panel with auto-guidance, where the right button lights up
- + Meets all current and future requirements in applicable standards for safe quick hitches
- + Ground pressure sensor for enhanced safety when switching tools
 - not possible to open the bucket lock with the bucket hanging off the ground
- + Audiovisual alarm system that alerts with sound and light when coupling
- + No need to modify the machine manufacturer's machine hitch locking function

Read more on our website: www.engcon.com



Automatic Quick Hitches

S40–S80

Q-Safe™

New level of secure quick hitches!
For all excavators in the 6-40 tonne weight classes.

Advantages

- » Designed for tiltrotator digging – the digging forces are distributed through the body of the hitch, not the hitch ram
- » The EC-Oil automatic quick hitch system connects the tiltrotator & hydraulic tools without the operator needing to leave the cab.**
- » Hydraulic locking with fourfold safety:
 1. Electronic surveillance detects when both attachment axles are correctly located
 2. A non-return valve prevents the hydraulic cylinder from opening even if a hose ruptures or there is a pressure drop
 3. Powerful, interior springs keep the hitch locked even if the electronics and hydraulics fail.
 4. The unique design of the lock bolt provides additional safety as the bucket axle bottoms against the hitch side plates and cannot therefore drop out of position even if all three of the above steps should fail.
- » The bucket can only be removed when it is under positive ground pressure (with engcon's locking system). This minimizes the risk of dropped buckets.



- » Front and rear detectors minimize the risk of accidents caused by swinging tools
- » Supplied as standard with external audible and visible warning signals to alert the surrounding area
- » Play-free design with double contact surfaces compared to many other hitch systems
- » Longer hooks (shark jaws) to make picking up tools safer and easier
- » Welded high-strength steel
- » Fits all excavators in the specified weight class independent of control system
- » The hook is classified for safety in compliance with: EN ISO 12100-1/A1:2009 and EN ISO 12100-2/A1:2009
- » Q-Safe is also fitted as standard equipment under engcon tiltrotators with hitch sizes S45-S80.

* S40 will come with EC-Oil in the spring of 2021

** Read more on page 4



Read more on page 4

Attachment brackets for EC-Oil

GS40-ECO*, GS45-ECO, GS50-ECO,
GS60-ECO, GS70-ECO, GS80-ECO

Adapt your hydraulic tools for EC-Oil.

For all excavators in the 6-33 tonne weight classes.

- » Bucket/attachment bracket adapted to EC-Oil™ connectors
- » Standard bolt pattern that fits engcon hydraulic tools or weldable bracket
- » Possible to equip with one or two EC-Oil blocks
- » Easy to adapt for all types of hydraulic tools
- » Robust, reliable and value-for-money
- » Constructed in high strength steel

** S40 will come with EC-Oil in the spring of 2021*

EC-Oil™



Bolted brackets with EC-Oil



Weldable brackets with EC-Oil

Attachment brackets

GS30–GS80

For all excavators in the 1-33 tonne weight classes

- » Easy to modify buckets for engcon hitches
- » Robust, reliable and value-for-money
- » Welded in high-strength steel



Other quick hitches

S30

For all excavators in the 1-2 tonne weight classes

- » Designed for tiltrotator digging – the digging forces are distributed through the body of the hitch, not the hitch ram
- » Hydraulic locking for speedy attachment and tool changes straight from the cab
- » Play-free connection
- » Robust, reliable and value-for-money
- » Low installation dimensions.
- » Low weight
- » Welded, high-strength steel
- » Can be supplied with hydraulic or mechanical locking



Detachable gripper

GRD45-GRD70

**engcon's detachable gripper is also retrofittable.
For all excavators in the 6-26 tonne weight classes.**

The gripper cassette simply hooks onto the quick hitch and is then locked in place and the hydraulics connected in a single action – a procedure that takes less than a minute. The gripper is angled at 15 degrees to the plane of rotation, giving a longer reach.



engcon's detachable gripper cassettes are available in two different designs; quick lock and manual.



Quick locking

The gripper cassette is locked and the hydraulics connected in one action using a 32 mm open-ended spanner. This allows the cassette to be attached or detached in less than a minute.



Bolts

Manual connection

The gripper cassette is fastened to the back section of the quick hitch using nuts & bolts. The hydraulics are connected manually using hose connectors.

** Applies to the quick lock model*



Detachable sweeper

SWD 45-SWD60

engcon's detachable sweeper is also retrofittable. For all excavators in the 6-19 tonne weight classes.

Just like with the gripper cassette, the rotating brushes can be retrofitted simply on the quick hitch by being hooked onto the hitch's two mounting hooks. The rotating brushes are then locked and connected to the hydraulics in a single action – quick and easy.

engcon's sweeper is driven by a powerful hydraulic motor and is raised or lowered by a hydraulic ram. The sweeper is flexible and its width can be adjusted for the job in hand, from cable sweeping to sweeping large areas. This reduces the need for manual labour and makes a safer workplace. The sweeper is available in several widths and is adapted for the new engcon quick hitch.





Integrated gripper GR20R2

Integrated gripper for EC214 and EC219*

The new integrated gripper is specially developed for the tough environments that grippers are exposed to on the railway, where a gripper will often be used to pull and lift heavy rails with excavators.

Advantages:

- » Robust construction designed for heavy and difficult usage, such as in the railway industry.
- » Angled down up to 42 degrees
- » Large grab width – 820 mm
- » Protected cylinders

* Standard hitch combinations: S45 and S60. Other hitch combinations may be available – please ask.



Stone and sorting grab

SG03, SG06, SG12, SG19, SG26, SG33

For all excavators in the 1,5-33 tonne weight classes

engcon's stone & sieve grabs in the SG series are suitable for everything from sorting to light demolition works where a powerful grab is needed. In combination with engcon's tiltrotators you get the accessibility needed and EC-Oil automatic quick hitch system is standard*

The advantages of SG grabs

- » The EC-Oil automatic quick connection system connects the hydraulics without the operator having to leave the cab.
- » The grab's claws are fitted with reversible wear bars
- » A load valve and pressure accumulator maintain gripping force for extended periods to ensure safe lifting
- » Complies with European safety standards
- » Expander bushings in major joints
- » Bolt-on bracket/attachment point makes switching brackets easy.

Accessories:

- » Tooth kit for better grip
- » Closed sides to convert the grab into a grab bucket

*Applies to grabs with QS40-QS80 top brackets



With teeth
(accessory)



With closed sides
(accessory)



Read more on page 4

Timber/combi grab

TG25HD–TG55HD



Read more on page 4

For all excavators in the 4-26 tonne weight classes

Together with the tiltrotator, engcon's combi Timber Grab Heavy Duty is the ultimate tool for round timber and pipe handling, and light sorting jobs. The grabs, which are reinforced with high-strength steel wear bars with a hardness of 400 Brinell for long life, can be used with a wide variety of hitches.

Advantages:

- » The EC-Oil automatic quick hitch system connects the hydraulics without the operator needing to leave the cab
- » Grab arms in high-strength steel for increased life
- » Grab tip wear bars with 400 Brinell hardness for best durability
- » A non-return valve built into the ram and an direct-mounted accumulator ensure the load is secure should any pressure drop occur.
- » Expander bolts in joints prevent unnecessary play
- » Bolt-on bracket/mounting makes switching brackets easy



Pallet forks

GH1000, GH1200, GHH1200, GHH1200L, GH1500, GHH1500



Read more on page 4

For all excavators in the 4-33 tonne weight classes

Hydraulic and mechanical pallet forks for all excavators. – A robust and cleverly engineered design for best visibility. Tempered forks guarantee a long service life.

NOTE! Always consult the applicable safety instructions for using the pallet fork on each individual machine. When using the pallet fork together with a tiltrotator, a load-holding valve must be fitted to the tiltrotator. All engcon tiltrotators are fitted with load-holding valves in the tilt cylinders as standard equipment.

- » The EC-Oil automatic quick hitch system connects the hydraulics without the operator needing to leave the cab.
- » Operation of hydraulic pallet forks is done from within the cab
- » Mechanical hydraulic pallet forks are held in the correct position with a robust latch and the position is adjusted manually.
- » Forged forks for increased durability and service life

GH = Mechanical fork widening,

GHH = Hydraulic fork widening

GHH1200L = Hydraulic fork widening, Light version for lighter machines.



Compactor

PP350, PP600, PP950



Read more on page 4

For all excavators in the 6-33 tonne weight classes

- » The EC-Oil automatic quick hitch system connects hydraulics
- » Compaction plate in hard-wearing steel
- » Side plating for grading filler
- » Open short ends allows quick and easy clearing of the top of the plate
- » Rubber joint optimise insulation with stiffness for grading
- » The vibrator unit and hydraulic parts are well-protected inside the side plates
- » Fitted with S-type mounting as standard
- » Complete with flow control valve
- » Complies with European safety standards
- » Tandem-connected weights
- » Bolt-on bracket/attachment point makes switching brackets easy
- » Bolt-on bracket/attachment point means dealers need keep fewer compactors of the same size in stock



Best in test!

engcon's PP600 compactor showed the best results in an independent test conducted by geologist Dr. H. Seeliger in Kassel, Germany, giving 103.2% after two passes and 101.6% after six passes.

Compactor

PP3200



Read more on page 4

For all excavators in the 6-26 tonne weight classes

- » The EC-Oil automatic quick hitch system connects hydraulics
- » Low flow requirement (35 litres) allows the PP3200 to be run directly off the extra connections on the tiltrotator
- » Variable working width
- » Specially adapted pack cushions
- » Compaction plate in hard-wearing steel
- » Side plating for grading filler
- » Open short ends allows quick and easy clearing of the top of the plate
- » Rubber joint optimise insulation with stiffness for grading
- » The vibrator unit and hydraulic parts are well-protected inside the side plates
- » Fitted with S-type mounting as standard
- » Complies with European safety standards
- » Bolt-on bracket/attachment point makes switching brackets easy
- » Bolt-on bracket/attachment point means dealers need keep fewer compactors of the same size in stock



Accessories:

Extension plates, trenching blade, specially adapted compactor pads for e.g. packing in sheet-pilings.

Sweeper roller

SR800–SR2000

For all excavators in the 6-33 tonne weight classes

engcon's sweeper rollers – Make the most of what the excavator has to offer and open up previously undreamed-of possibilities in a wide range of speciality areas. Regardless of whether you're sweeping soil, sand, gravel or snow, the brush will very quickly become a favourite tool you just won't be able to live without. Areas such as road crossings, pedestrian walkways, tramway points, etc can be cleared as well as sweeping road sand and gravel, brushing grassed areas, foundations, rocks and more. The only limit is your imagination. A hydraulic motor provides the power and a chain drive which enables the brush rotation speed to be adjusted. The open design allows unsurpassed, service-friendly access, and the standard polypropylene brushes can be replaced quickly and easily.



EC-Oil
STANDARD
Read more on page 4



Compatible with EC-Oil, allowing automatic connection without the operator having to leave the cab.

EC-Oil automatic quick hitch system is a standard. The sweeper roller can be connected without the driver having to leave the cab. Screwed bracket/attachment provides the opportunity to easily change the attachment as needed and reduces the need for dealers to have several sweeper rollers of the same size in stock.

Grading beam

GRB1250–GRB3000

With engcon's grading beam, you can grade large areas quickly and efficiently.

The grading beam is a smart, flexible solution as it has a bolt-on bracket/hitch with the same bolt pattern as other tools (e.g. rock and sorting grabs, compactors and sweeper rollers) from engcon.

The side beams can be extended with bolt-on 500 mm extensions. This allows the grading material to be held within the confines of the width of the grading beam.

What's more, engcon's grading beam has cutters on the leading edge and wear bars under the entire structure. This means a long life, making the grading beam even more profitable. The journaled compactor roller can be raised and lowered to achieve the best setting for your particular needs. engcon's grading beam comes in five different widths according to the size of tiltrotator.



Robust design

- » Bolt-on mounting/bracket
- » Cutting steel at the leading edge
- » Wear bars under the entire structure
- » Extendable side beams
- » Journaled compactor roller
- » Compactor roller can be raised and lowered
- » Bolt-on bracket/attachment point makes switching brackets easy
- » Bolt-on bracket/attachment point means dealers need keep fewer grading beams of the same size in stock

NOTE: engcon's grading beam is even more efficient in combination with a tiltrotator, but it is then important to consider the loads that the tiltrotator will be subjected to. Use the grading beam for the purpose for which it is designed – surface grading. Large quantities of material can be moved quickly and efficiently with engcon's range of buckets.



Tools to take on the toughest jobs

engcon offers a wide range of tools and attachments, adapted to your specific needs. The tools and attachments are manufactured in high-quality steel and are designed to provide the greatest flexibility and crack resistance. Wear bars and cutters have a hardness of around 500 Brinell. We also reinforce our tools with Hardox on the most exposed positions to manage an extra tough load.

Deep-digging bucket

DB01–DB32

For all excavators in the 1-33 tonne weight classes

engcon deep-digging bucket – Robust construction for tough jobs. A favourite for anyone needing to excavate and dig in difficult conditions where fast penetration and easy filling are prioritised, for example in trenching and other mass transfers requiring capacity. Like all engcon buckets, the digging bucket has a long floor and cutaway sides to reduce drag when digging.

The bucket can be fitted with the following accessories on request:

- » Tooth kit*
- » Tooth cover
- » Blade teeth

** When selecting a tooth kit, engcon buckets are fitted with the Cat J system as standard equipment. For other tooth systems, check availability with engcon.*



Cable bucket

CB01–CB29

For all excavators in the 1,5-33 tonne weight classes

engcon's cable bucket – developed for precision excavation with minimal width for e.g. cables or other services requiring narrow trenches. Its deep profile means better accessibility beneath intersecting cables and pipes and also allows deep trenching without the need for the tiltrotator to go below surface level.

engcon's cable buckets are available in two models – Standard and tapered (C)

Standard is the conventional type with parallel side plates for excavating ditches with vertical sides.

The tapered model has a narrower blade than the standard cable bucket but with the same width top, producing a narrower trench bottom with slightly sloping sides.

engcon's cable buckets are made from high-quality steel. As with other engcon buckets, the cutters and other exposed wear surfaces have a hardness of 500 Brinell.



Standard

A factory-fitted tooth kit is available as an optional extra.



Tooth kit, type Cat

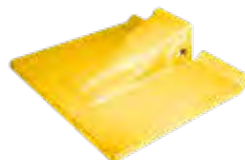

Blade teeth provide smooth ditch bottoms



Conical



Riddle bucket

SB02–SB29

For all excavators in the 1,5-33 tonne weight classes

The engcon series of riddle buckets is designed for quick, simple sorting. The riddle buckets require no hydraulics; they are built from the highest quality steel where the cutters and steel ribs have a hardness of 500 Brinell – the same high quality that can be found on every engcon bucket. All for increased efficiency and a long service life.



Riddle bucket

SKB02–SKB29

For all excavators in the 1,5-33 tonne weight classes

The SKB sorting bucket is designed to more easily get beneath the material intended for sorting. It has a slightly narrower shape than the engcon SP sorting bucket and its long base and low side panels make it easier to get beneath e.g. asphalt or other material intended for sorting. The base ribs run along the length of the bucket, allowing material to slide easily in and out.

The SKB sorting bucket requires no hydraulics and is thus ideal for simple sorting where e.g. finer material is required for backfill or some other use. Cutting steel, lower side plates and ribs consist of high-strength wear steel with hardness of up to 500 brinels, which guarantees high efficiency and long service life.



Grading bucket

GB01–GB29

For all excavators in the 1-33 tonne weight classes

engcon's grading bucket – Optimised together with experienced contractors for use together with the tiltrotator. Chamfered corners all round to avoid collisions with house walls and other objects that can potentially be damaged by the rotating bucket. Conical form for easier filling and an angle of 16 degrees between mounting and bottom for easier bucket rotation without losing material.



Advantages of the engcon grading bucket

- 1 Chamfered corners to avoid collision
- 2 Tiltrotator-adapted ceiling angle
- 3 Hardox-reinforcements on other wear surfaces
- 4 Conical form for easier filling and better release
- 5 Wear and cutting steel - 500 Brinell hardness

Water & sewerage bucket

TB07–TB23

For all excavators in the 8-23 tonne weight classes

engcon's water & sewerage bucket – Specially designed for excavating water and sewerage trenches, the bucket has a slightly conical shape and shorter floor which facilitates rotating the bucket in the trench. Like the other buckets in engcon's range, the water & sewerage bucket is reinforced with Hardox at the most exposed points.



Gripper-adapted bucket series

A new gripper-adapted bucket series has been developed in parallel with the GRD, the detachable gripper, where the rear of the bucket is designed with a recess that aligns with the gripper's counterhold and consequently functions as an extended support for the item being gripped, such as a pole or pipe.





Tarmac Cutter

TC02–TC20

For all excavators in the 1,5-33 tonne weight classes

engcon's Tarmac Cutter – a cutter from engcon allows you to make precise cuts and avoid digging up asphalt unnecessarily. Can also be used for precise cuts on grass surfaces and other locations where accuracy is called for.



Ripper

R5–R30

For all excavators in the 1,5-33 tonne weight classes

engcon's ripper – With engcon's ripper you'll find no problem in penetrating hard ground. The ripper is optimised for the best ripping ability and breakout force in hard material.





ENGCON JOYSTICK

Enjoy working with good ergonomics and functionality



engcon's joysticks for excavators combine good ergonomics and functionality. The joystick is developed to meet the requirements for increased safety and more control functions.

Designed in collaboration with contractors, each joystick can be fitted with three rollers and seven buttons – an FNR switch is also available where joystick steering on wheeled excavators is required.

The joystick has an integrated hand support for the wrist to rest on without affecting the excavator movements. The

hand support is flexible and can be adapted to different hand sizes.

engcon's joystick also provides the operator new methods of operation. The joystick's rollers are intended for use by the thumb, index and middle fingers - something that's unique to engcon. In this way the operator can operate six proportional tiltrotator and excavator functions simultaneously as standard when necessary*.

* additional rollers can be accommodated

ENGCON CONTROL SYSTEM

Proportional control system with remote support

Our proportional control system meets the high expectations place on all components such as hydraulics, electronics and software. Together with engcon's tiltrotators and quick hitches, the control system creates a safer working environment. engcon's control system provides, among other things, the option of track control, wheel steering, and boom slew. Via an app in your smartphone, there is the option of remote support as a complement to PC and USB cable. The product meets safety standard ISO 13849-1.

The control system meets all current and known future safety requirements.



Advantages:

- » Proportional/stepless control of tiltrotator and implements
- » Meets international safety standard SS-EN ISO 13849-1
- » Fitted with an automatic basic calibration function for quick starts
- » Automatically backs up operator settings
- » Option of track control, wheel steering, boom slew and other excavator functions
- » Function settings and tools can be adjusted using an android phone/tablet with the Microprop App via Bluetooth for up to four different operators
- » Controls up to six proportional functions as standard and a further 14 on/off functions with MIG2 joysticks
- » Suitable for most machines on the market
- » Ability to create adapted tool programmes
- » Opportunity to create three individual driver programs

The DC2 control system meets all current and known future safety requirements.

* additional rollers and functions can be accommodated

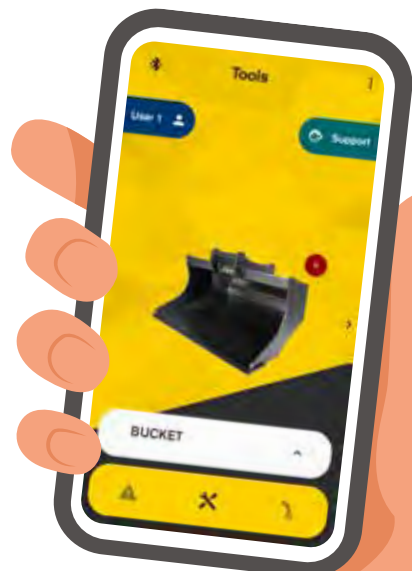
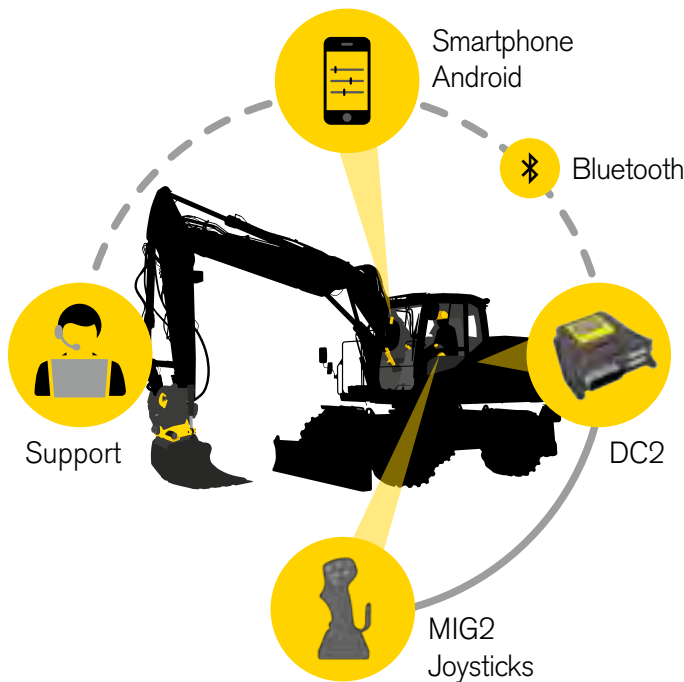



engcon Positioning System

engcon is now taking a further step into the future, by adapting their products with excavator guidance systems/machine sensors. engcon Positioning System works with engcon's tiltrotators EC209 and up.

Prerequisites

The technology is based on the system delivering signals to the excavation system that the customer has on their excavator.

engcon supplies the rotary encoder and the excavation system supplier delivers the tilt sensor.

With the combination of engcon Positioning System, excavator models, and certain brands of excavator guidance systems, the auto-tilt and Auto-rotate function can also be obtained. Contact your excavator system supplier for more information.

Advantages

Together with the excavator guidance system, engcon Positional System reduces the need for conventional setup. The driver can see the excavation area via the machine control system's display in the cab. This control allows the driver to excavate the correct amount of material gives many benefits:

- » Time
- » Reduced fuel consumption
- » Reduced machine and tool wear
- » Save time for other units such as, truck/dump truck as drive away the excavated masses
- » Adapted for engcon's proportional control system but possible to mount on other control systems
- » Completely independent of model or make of control system via own cabling
- » Possible to order/retrofit to all tiltrotators from EC209 and up

Technical data

Please direct any questions to your local engcon office.

Technical data may vary. We reserve the right to make changes without prior notice.

Tiltrotator

Specifications	EC02B	EC204	EC206	EC209	EC214	EC219	EC226	EC233
Width A: (mm)*	180	267	286	277	320	396	426	501
Width B: (mm)*	155	161	220	250	285	315	340	385
Width C: (mm)*	160	169	219	273	303	310	340	385
Length overall D: (mm)*	435	463	500	561	665	737	760	878
Construction height E: (mm)*	from 245	from 310	from 380	from 425	from 457	from 480	from 500	from 673
Weight: (kg)*	77	116	170	287	385	447	632	812
Tilt:	2x40°	2x45°	2x45°	2x45°	2x45°	2x45°	2x45°	2x45°
Rec hydraulic flow DC2/SS10 (l/min):	25	30	40	60	80	120	120	120
Rec hydraulic flow SS9 tilt/rotation: (l/min):	7/20	10/25	15/30	35/40	35/50	65/70	70/70	70/70
Max hydraulic pressure: (MPa)	22	22	22	22	22	22	22	25
Standard attachments:	S30	S40	S40, QS45, QS50	QS45, QS50	QS45, QS50, QS60	QS60	QS70	QS70, QS80, S2
Max bucket width rec by engcon: (mm)	900	1 000	1 200	1 300	1 600	1 700	2 000	2 200
Max breakout torque: (kNm)	20	28	45	74	126	186	270	340
Base machine weight: (t)	1,5-2,5	2-4	4-6	6-9	9-14	14-19	19-26	24-33

*Standard attachment

Stand for tiltrotator

Specifications	
Length: (mm)	1200
Width: (mm)	800
Height without attachment: (mm)	150
Weight without attachment: (kg)	82

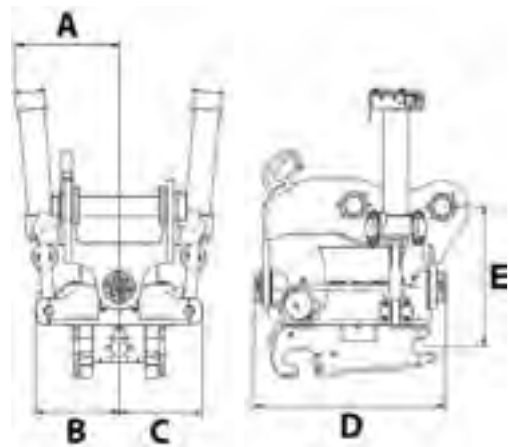

Automatic Quick Hitches

Specifications	S40	S45	S50	S60	S70	S80
Axle diameter A: (mm)	Ø40	Ø45	Ø50	Ø60	Ø70	Ø80
Width B: (mm)	200	290	270	340	450	590
Length C: (mm)	300	430	430	480	600	670
Construction height D: (mm)	135	140	140	170	190	270
Weight*: (kg)	50	100	100	180	290	370
Recommended hydraulic pressure open/closed (MPa)	21-25	21-25	21-25	21-25	21-25	21-25
Max hydraulic pressure: (MPa)	35	35	35	35	35	35
Base machine weight: (t)	2-6	6-11	6-11	12-19	20-30	27-40



*Depending on attachment

Attachment brackets

Specifications	GS30/ 150	GS30/ 180	GS40/ 200	GS40/ 240	GS45	GS50	GS60	GS70	GS80
Axle diameter A: (mm)	Ø30	Ø30	Ø40	Ø40	Ø45	Ø50	Ø60	Ø70	Ø80
Width B: (mm)	150	180	200	240	290	270	340	450	590
Length C: (mm)	200	230	300	300	430	430	480	600	670
Suitable for engcon RF:	S30	S30	S40	S40	S45	S50	S60	S70	S80

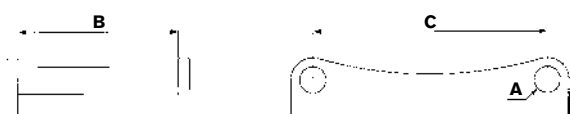

S-Quick hitch

Specifications	S30	S30
Axle diameter: (mm)	Ø30	Ø30
Width: (mm)	150	180
Length: (mm)	200	230
Construction height: (mm)*	110	110
Weight: (kg)*	10	15
Recommended hydraulic pressure open/closed	21/3-6	21/3-6
Max hydraulic pressure: (MPa)	22	22
Base machine weight: (t)	1-2	1-2

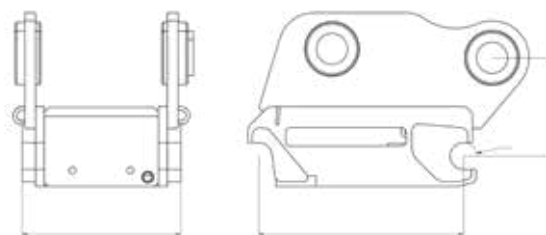

*Depending on attachment

Detachable gripper

Specifications	GRD45/50	GRD60	GRD70
Grab width A: (mm)	610	820	950
Width B: (mm)	270	355	410
Length C: (mm)	720	870	900
Clamping force (tip - tip) at 21MPa: (kg)	1 500	2 200	2 200
Max load: (kg)	1 500	2 000	2 000
Weight: (kg)*	99	143	158
Max hydraulic pressure: (MPa)	22	22	22
Fits quick hitch:	QSD45, QSD50	QSD60, QSM60	QSM70

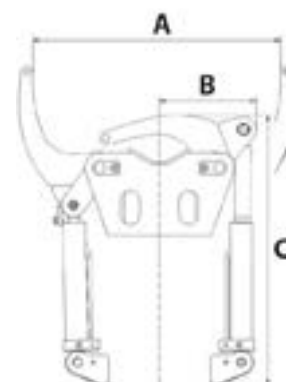

Detachable sweeper

Specifications	SWD45	SWD60
Length, cassette A: (mm)	586	665
Length, arm B: (mm)*	875	975
Width, cassette C: (mm)	362	423
Width, guard D: (mm)**	450, 1 100, 1 600	450, 1 100, 1 600
Height, guard E: (mm)	660	660
Max total length A+F (mm)***	1 501	1 998
Diameter, brush G: (mm)***	600, 700, 915	600, 700, 915
Width, brush H: (mm)	420, 1 100, 1 600	420, 1 100, 1 600
Maximum weight: (kg)**	186	210
Oil flow min/max: (l/min)	20/60	20/60
Fits quick hitch:	QSD45, QSD50	QSD60, QSM60

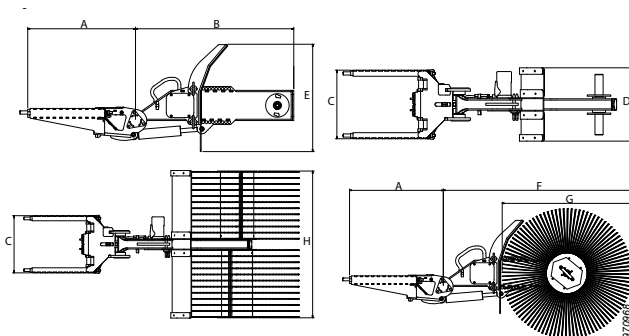

* In the standard version
 ** Depends on sweeper brush
 *** 915 mm can only be used with long arm (975 mm)

Integrated gripper

Specifications	GR20R2
Largest grab width A: (mm)	820
Width B: (mm)	380
Length: (mm)	Depending on the hitch
Weight: (kg)	140
Clamping force at 21 Mpa: (kg)	1 750
Angled at 35-42° depending on the hitch	
Detachable	
Protected cylinders	

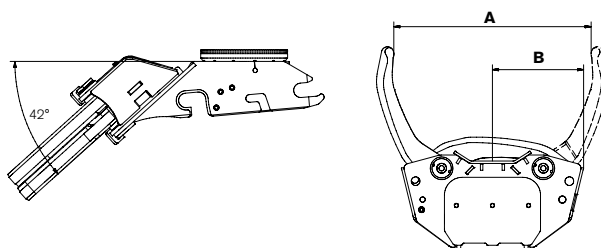

Note! GR20R2 cannot be combined with all quick hitches on the market. Contact engcon for further information.

Stone and sorting grab

Specifications	SG03	SG06	SG12	SG19	SG26	SG33
Grab width A: (max. mm)	750	1 110	1 660	1 790	1 990	2 575
Grab width A: (min. mm)	0	0	0	0	0	0
Cutting width B: (mm)	400	505	715	860	860	1 170
Jaw length C: (mm)	490	460	680	790	870	1 180
Height D: (mm)	550	580	790	960	1 070	1 360
Volume, with side plates: (l)	42	83	220	336	420	930
Gripping force: (kN)	5,7	8,7	15	19	25	45
Max hydraulic pressure: (MPa)	22	22	22	22	22	22
Weight: (kg)*	108	180	425	646	755	1 400
Grab area: (m ²)	0,12	0,17	0,34	0,42	0,52	0,85
Recommended machine weight: (t)	1,5-3	3-6	6-12	12-19	18-26	24-33
Recommended tiltrotator:	EC02	EC204 EC206	EC206 EC209 EC214	EC214 EC219	EC219 EC226	EC226 EC233

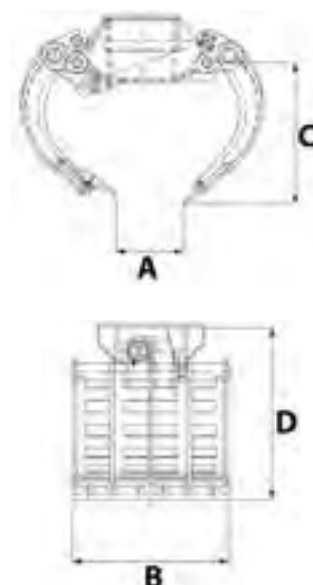

*Depending on attachment

Timber/combi grab

Specifications	TG25HD	TG28HD	TG42HD	TG55HD
Max grab width: (mm)	1 450	1 540	1 900	2 510
Max load: (t)	3	5	6	10
Height, fully open: (mm)	759	889	1 039	1 146
Height, fully closed: (mm)	526	659	751	946
Width: (mm)	460	595	677	802
Clamping force (tip - tip) at 21MPa (kN)	6,8	12,42	20,4	31,86
Max hydraulic pressure: (MPa)	22	22	22	22
Weight: (kg)	195	360	595	1 070
Grab area: (m ²)	0,25	0,28	0,42	0,55
Recommended machine weight: (t)	4-9	9-14	12-19	19-26

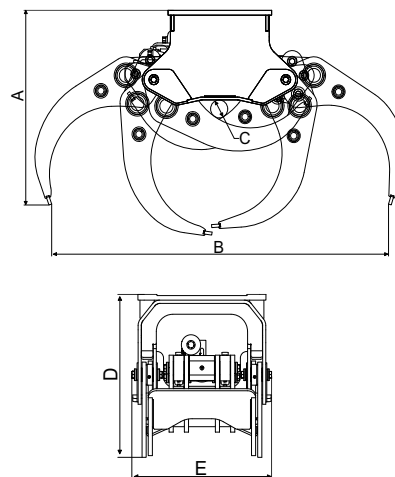

Pallet fork

Specifications	GH1000	GH1200	GH1200	GH1200	GH1500
Width: (mm)	1 000	1 200	1 200	1 200	1 500
Blade: (mm)	100x40x1 200	125x45x1 200	125x50x1 200	125x50x1 500	125x50x1 500
Weight: (kg)*	180	360	372	409	420
TP500	2,9 T	4,7 T	5,7 T	5,7 T	5,7 T

Specifications	GHH1200	GHH1200L	GHH1200L	GHH1500
Width: (mm)	1 200	1 200	1 200	1 500
Blade: (mm)	125x45x1 200	100x40x1 200	125x45x1 200	125x50x1 500
Weight: (kg)*	400	260	313	570
TP500	4,7 T	2,9 T	4,7 T	5,7 T

* Depending on bracket

Compactor

Specifications	PP350	PP600	PP950	PP3200
Compaction force: (kg)	3 500	6 000	9 500	3 200
Compaction area: (m ²)	0,42	0,58	0,90	0,4-0,56
Max hydraulic pressure: (MPa)	22	22	22	22
Rec hydraulic flow: (l/min)	68	120	120	34
Max rec return hose pressure: (MPa)	1	1	1	2,5
Weight excluding attachment point: (kg)	390	620	900	470
Length: (mm)	890	1 050	1 270	1 000
Width: (mm)	620	720	900	500-700
Height: (mm)	450	520	600	590

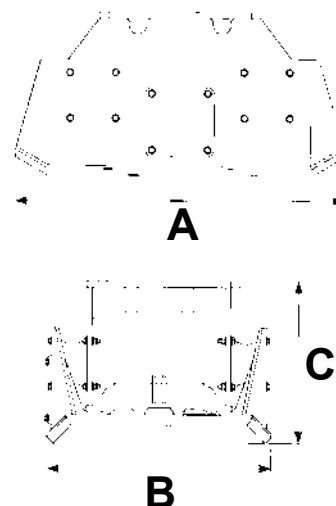

Rotating brush

Specifications	SR800	SR1300	SR1600	SR1800	SR2000
Min hydraulic flow: (l/min)	20	20	20	20	20
Max hydraulic flow: (l/min)	60	60	60	60	60
Weight excluding attachment point: (kg)	210	240	260	275	290
Width A: (mm)	800	1 300	1 600	1 800	2 000
Height B: (mm)	1 257	1 257	1 257	1 257	1 257
Length C: (mm)	1 060	1 060	1 060	1 060	1 060

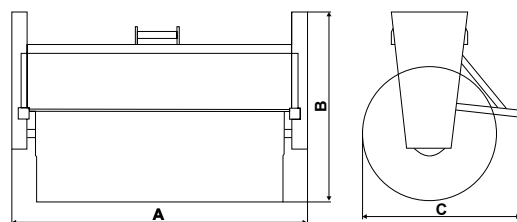

Grading beam

Specifications	GRB1250	GRB1500L	GRB1500	GRB 2000	GRB 2500	GRB 3000
Width (mm):	1 250	1 500	1 500	2 000	2 500	3 000
Depth (without extensions) (mm):	962	962	1 000	1 000	1 000	1 000
Height (without mounting) (mm):	275	275	387	387	387	387
Diameter, roller (mm)	178	178	245	245	245	245
Weight (kg):	195	233	306	482	563	645

Deep-digging bucket

Specifications	DB01	DB02	DB02	DB02	DB03	DB05	DB06	DB06	DB07	DB07	DB09	DB09	DB11	DB11	DB11	DB12	DB12	DB12
Volume: (l)	50	70	90	90	120	160	200	200	250	250	350	350	400	400	400	500	500	500
Width: (mm)	400	450	550	550	550	600	600	600	700	700	700	700	700	700	700	800	800	800
Weight: (kg)	35	50	55	60	75	100	125	140	210	215	230	235	280	285	300	320	320	330
Attachment:	S30	S30	S30	S40	S40	S40	S40	S45	S45	S50	S45	S50	S45	S50	S60	S45	S50	S60

Specifications	DB13	DB13	DB14	DB14	DB16	DB16	DB18	DB18	DB18	DB21	DB21	DB23	DB23	DB26	DB26	DB26	DB29	DB29	DB32
Volume: (l)	600	600	650	650	750	750	900	900	900	1 100	1 100	1 250	1 250	1 400	1 400	1 400	1 600	1 600	1 800
Width: (mm)	850	850	900	900	1 000	1 000	1 000	1 000	1 000	1 100	1 100	1 200	1 200	1 300	1 300	1 300	1 450	1 450	1 700
Weight: (kg)	500	570	520	590	600	630	680	715	710	940	920	1 150	1 150	1 330	1 350	1 320	1 440	1 450	1 720
Attachment:	S60	S1	S60	S1	S60	S1	S60	S70	S1	S70	S1	S70	S2	S70	S80	S2	S70	S2	S80

Cable bucket

Specifications	CB01	CB02	CB03	CB03	CB05	CB05	CB05	CB08	CB08	CB08	CB10	CB10C
Volume: (l)	35	60	90	90	130	130	130	155	155	155	160	130
Width: (mm)	240	290	290	290	340	340	340	400	400	400	460	300
Weight: (kg)	25	35	55	55	70	85	85	83	95	95	160	170
Attachment:	S30	S30	S30	S40	S40	S45	S50	S40	S45	S50	S50	S50

Specifications	CB15	CB15C	CB15	CB15C	CB20	CB20	CB20	CB25	CB25	CB29	CB29	CB29
Volume: (l)	350	350	350	350	400	400	400	550	550	800	800	800
Width: (mm)	560	300	560	300	660	660	660	600	600	700	700	700
Weight: (kg)	290	255	320	285	320	360	360	590	615	744	777	798
Attachment:	S60	S60	S1	S1	S60	S70	S1	S70	S80	S70	S80	S2

Riddle bucket

Specifications	SB02	SB02	SB02	SB04	SB06	SB06	SB08	SB08	SB11	SB11	SB14	SB15	SB17	SB20	SB24	SB29
Volume: (l)	90	30	130	200	300	300	370	370	500	500	650	750	900	1 100	1 400	1 600
Width: (mm)	900	900	900	1 000	1 200	1 200	1 300	1 300	1 400	1 400	1 600	1 600	1 700	1 700	2 000	2 000
Diameter: (mm)	22	22	22	22	22	22	30	30	30	30	30	45	45	45	45	45
Gap: (mm)	30	40	40	50	50	50	50	50	50	50	50	65	70	70	70	70
Weight: (kg)	80	86	91	44	166	177	292	295	320	323	442	628	697	920	1 046	1 268
Attachment:	S30	S30	S40	S40	S40	S45	S45	S50	S45	S50	S60	S60	S60	S70	S70	S70

Riddle bucket

Specifications	SKB02	SKB04	SKB06	SKB09	SKB14	SKB17	SKB23	SKB29
Volume: (l)	70	170	220	400	620	850	1 300	550
Width: (mm)	600	600	800	1 000	1 300	1 300	1 500	1 500
Gap: (mm)	44	41	47	51	62	62	62	62
Weight: (kg)	49	108	166	291	496	604	1 072	1 231
Attachment:	180	S40	S45	S45	S60	S60	S70	S70

Grading bucket

Specifications	GB01	GB02	GB02	GB02	GB03	GB04	GB04	GB05	GB05	GB06	GB06	GB08	GB08	GB08	GB08	GB11	GB11	GB11
Volume: (l)	55	90	130	130	150	200	200	250	250	300	300	370	370	400	400	450	500	500
Width: (mm)	800	900	900	900	1 100	1 000	1 000	1 200	1 200	1 200	1 200	1 300	1 300	1 400	1 400	1 400	1 400	1 400
Weight: (kg)	60	75	80	85	110	135	140	145	155	155	160	260	260	255	265	320	370	370
Attachment:	S30	S30	S30	S40	S40	S40	S45	S40	S45	S40	S45	S45	S50	S40	S50	S45	S45	S50

Specifications	GB13	GB13	GB14	GB15	GB15	GB17	GB17	GB17	GB20	GB20	GB20	GB20	GB22	GB24	GB24	GB29	GB29	GB29
Volume: (l)	600	600	650	750	750	900	900	900	1 100	1 100	1 100	1 100	1 250	1 400	1 400	1 600	1 600	1 600
Width: (mm)	1 600	1 600	1 600	1 600	1 600	1 700	1 700	1 700	1 700	1 700	1 700	1 700	1 900	2 000	2 000	2 000	2 000	2 000
Weight: (kg)	450	490	460	660	690	700	740	730	940	980	970	980	1 060	1 150	1 150	1 460	1 490	1 460
Attachment:	S60	S1	S60	S60	S1	S60	S70	S1	S60	S70	S1	S2	S70	S70	S2	S70	S80	S2

Water & sewerage bucket

Specifications	TB07	TB07	TB07	TB09	TB12	TB12	TB14	TB14	TB14	TB14	TB16	TB16	TB18	TB21	TB23
Volume: (l)	250	250	250	350	500	500	600	600	650	650	700	700	900	1 100	1 250
Width: (mm)	600	600	600	700	800	800	800	800	830	830	900	900	900	1 100	1 200
Weight: (kg)	202	213	214	250	325	340	510	520	525	520	550	550	750	1 075	1 300
Attachment:	S40	S45	S50	S50	S50	S60	S60	S1	S60	S1	S60	S70	S70	S70	S70

Tarmac Cutter

Specifications	TC02	TC02	TC05	TC10	TC10	TC15	TC20	TC20	TC20
Diameter: (mm)	Ø370	Ø370	Ø370	Ø470	Ø470	Ø470	Ø470	Ø470	Ø470
Cutting depth: (mm)	100	100	100	150	150	150	150	150	150
Weight: (kg)	29	30	40	55	60	70	90	110	200
Attachment:	S30/150	S30/180	S40	S45	S50	S60	S70	S80	S1

Ripper

Specifications	R5	R5	R10	R10	R15	R20	R20	R20	R30	R30	R30
Height: (mm)	600	600	700	700	900	1 200	1 200	1 200	1 400	1 400	1 400
Weight: (kg)	50	65	110	110	170	370	410	390	680	720	690
Attachment:	S30	S40	S45	S50	S60	S60	S70	S1	S70	S80	S2



New functions for the excavator – new jobs for the company

Do you want to work more efficiently and identify new business opportunities?
The tiltrotators and tools from engcon are changing the world of digging.

With System engcon and EC-Oil you will be able to change tasks quickly and increase both the degree of usage and profitability for your excavator or backhoe loader.
System engcon products are compatible with one another and turn your excavator into a multitool that can do all kinds of things.

Dealers:

engcon[®]

engcon Australia 62 Power Street. St Marys, NSW 2760
Phone 02 8328 0690 | www.engcon.com | australia@engcon.com