



C4000

Two great meters in one

C4000 bulk range of combination cold water meters

C4000 combination cold water meters

Combining two outstanding Elster metering technologies in one extremely compact unit, the C4000's innovative in-line design delivers highly accurate bulk flow metering for applications with large variations in flow rate, helping to ensure optimum revenue collection.

Available in a range of four sizes and suitable for flow rates up to 250 m³/h, the C4000 features an innovative in-line design which delivers significant benefits, not only at installation but throughout its working lifetime. Offering the benefits of inductive register technology and combining the performance of both the H4000 and V200 range of meters, the C4000 measuring range ensures maximum revenue collection. The C4000 complies with all relevant international quality standards.

Information with intelligence

To deliver a complete metering system that addresses key efficiency objectives for water providers, the C4000 is designed to provide the level of information demanded by today's revenue management applications. To achieve this, the product offers a range of intelligent features, such as leakage alarms, data logging and tariffs. The meter is also fully compatible with Elster's range of intelligent meter reading systems, enabling the product to play an important role in revenue management, as well as improving customer service.



Key features

- Two inductive registers for improved output performance and security
- High turndown ratio
- Highly accurate bulk flow metering for applications with large variations in flow rate
- Designed to maximise revenue collection
- Compact, in-line construction for easy installation
- Available in sizes from 50mm to 100mm
- Longer wear life for optimum accuracy
- Meets Class B approval for the primary Woltmann meter and performs to Class C for the secondary V200 volumetric meter

Inductive target for bi-directional pulse communications

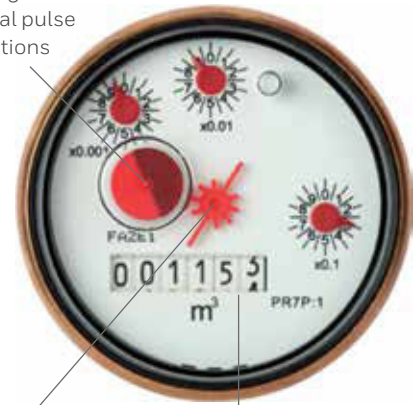

Star tell-tale for easy-to-see flow detection

Easy to read 6-figure display for sizes 50mm to 100mm

Compact, cost-effective, dependable

With a compact in-line design that simplifies the specification process by eliminating the need to differentiate between left or right-handed by-passmeters, the C4000 also features an easy-change metering insert, carrying both primary and secondary metering modules. This can be removed as a complete assembly, significantly reducing the time required for calibration, maintenance or replacement. As with all Elster meters, the product is designed and manufactured to rigorous quality standards for trouble-free operation, whatever its working environment. The C4000's superb design offers many features which increase its life cycle and reduce costs, including wear-resistant jewelled rotor bearings, tungsten carbide thrust pads and stub spindles with factory-potted moisture resistant electrical connections.

Enhanced communications and security

Using an inductive register to deliver enhanced communications performance and tamper-proof security, the C4000 provides effective protection against fraud. Compatible with PR6 and PR7 inductive pulse transmitters, the product features both high- and low speed bi-directional pulse capabilities as standard, and is fully compatible with other common ancillary devices including data loggers and AMR systems.

In-line strainer

The use of an Elster in-line strainer is recommended to protect the rotor and help reduce the effect of turbulence.

Maximum length flow straightening vanes

Hard surface rotor bearings – tungsten carbide and synthetic sapphire

Low mass rotor with hydrodynamic thrust relief

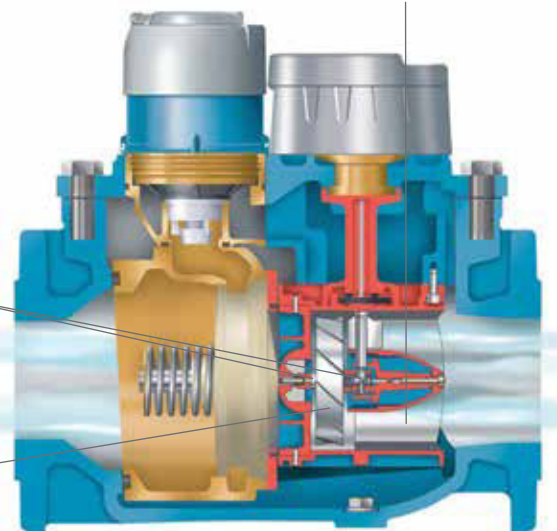

C4000

Product Specification



C4000 COMBINATION METER

METER SIZE (mm)	50	65	80	100
MAIN METER (MECHANISM)	H4000	H4000	H4000	H4000
BY-PASS METER (INSERT)	V200	V200	V200	V200
	(20mm)	(20mm)	(20mm)	(20mm)

OVERALL LENGTH

METER SIZE (mm)	50	65	80	100
ISO 4064 (mm)	300	300	350	350
DIN 19625 - WS (mm)	270	-	300	360

PERFORMANCE (m³/h)

METER SIZE (mm)	50	65	80	100
QMAX COMB. ±2% ACC.	50	50	200	250
QN COMB. ±2% ACC.	25	25	120	180
QN - BY-PASS METER ±2% ACC.	2.5	2.5	2.5	2.5
QT COMB. ±2% ACC.	0.0225	0.0225	0.0225	0.0225
QMIN COMB. ±5% ACC.	0.015	0.015	0.015	0.015
ISO 4064 QMAX ±2% ACC.	30	30	80	120
FLOW AT 0.6 BAR HEADLOSS	31	31	112	120
FLOW AT 0.1 BAR HEADLOSS	40	40	145	155
TURNDOWN RADIO	3,333	3,333	13,333	16,667

CHANGEOVER VALVE (m³/h)

METER SIZE (mm)	50	65	80	100
OPENING FLOW	1.8	1.8	2.2	2.4
CLOSING FLOW	1.2	1.2	1.2	1.4

DIMENSIONS

METER SIZE (mm)	50	65	80	100
OVERALL LENGTH (A)	270-300	300	300-350	350-360
HEIGHT (B)	80	86	104	115
DIAMETER (C)	166	186	201	228
HEIGHT (D)	225	225	245	255
HEIGHT WITH LID OPEN (E)	291	291	316	321
WIDTH (F)	105	105	125	140
WIDTH (G)	100	100	125	140
MECHANISM REMOVAL (H)	400	400	475	500
WEIGHT (KG)	23-25	27	33-35	40-41

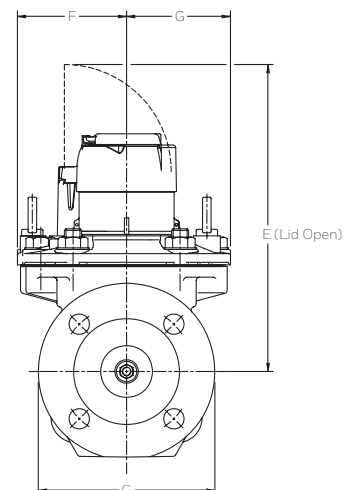
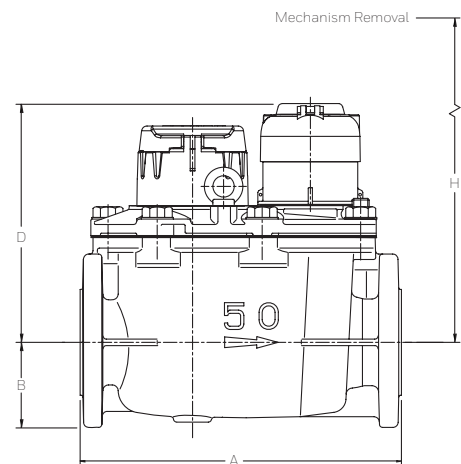
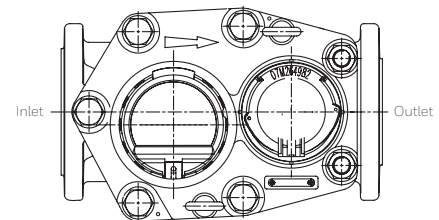

TYPICAL ACCURACY CURVE

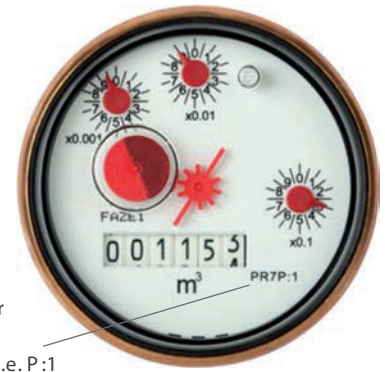
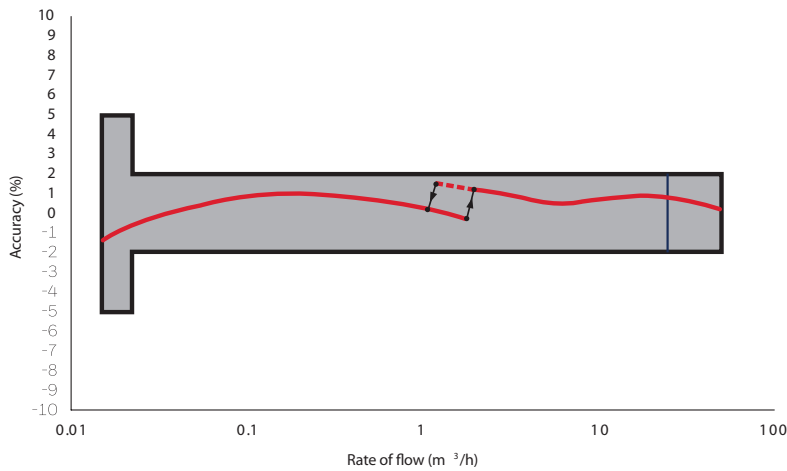

On this example 50mm C4000 register, the user can identify from the dial plate both the:

- Type of pulser to use, i.e. PR7
- Pulse factor, i.e. P:1

PR7 - DESIGNED FOR THE H4000 RANGE OF BULK METERS

PULSE CONNECTIVITY

Calculating pulse weights when fitted with PR7 inductive pulser:

Pulse weight is calculated by multiplying the register 'pulse factor' (P) by the PR7 'K-factor' (K); Pulse weight (litres per pulse) = P x K.

SIZE	PULSE FACTOR	K-FACTOR			
		K1	K10	K100	K1000
40mm	P:1	1 ltr	10 ltrs	100 ltrs	1,000 ltrs
50mm	P:1	1 ltr	10 ltrs	100 ltrs	1,000 ltrs
65mm	P:1	1 ltr	10 ltrs	100 ltrs	1,000 ltrs
80mm	P:1	1 ltr	10 ltrs	100 ltrs	1,000 ltrs
100mm	P:1	1 ltr	10 ltrs	100 ltrs	1,000 ltrs

On the PR7 unit the user can identify from the label the K-factors for each output channel

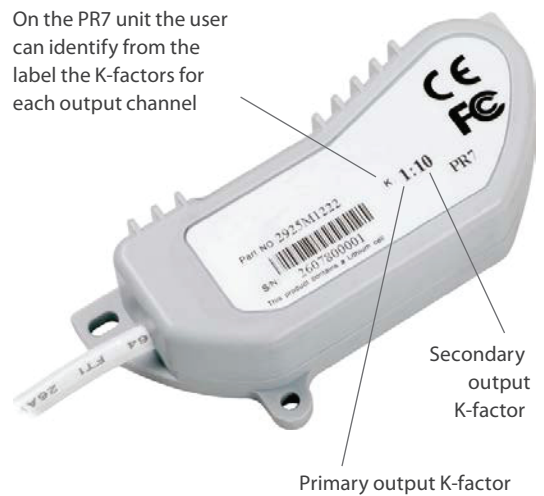

PR7 is an open collector pulse transmitter suitable for data logging, AMR and telemetry equipment. Check with your equipment supplier for full details of compatibility.

The PR7 with a K factor of 1 should be used with advanced data loggers, those capable of accepting a 5ms width impulse. Other outputs (K < > 1) have a variable pulse width. These can be used with any data logger.

Pressure equipment directive 97/23/EC. This product is applicable in networks for the supply, distribution and discharge of water and associated equipment and is therefore exempt.

PR6 - DESIGNED FOR THE V200 RANGE OF VOLUMETRIC METERS

PULSER FACTOR	PULSER TYPE	K FACTOR	PRIMARY OUTPUT PULSE WEIGHT LITRES/PULSE	SECONDARY OUTPUT PULSE WEIGHT LITRES/PULSE
PR6P:1	1 ltr	10 ltrs	1	1
PR6P:10	1 ltr	10 ltrs	10	10

The C4000 needs a PR6 for the V200 volumetric meter and a PR7 for the Woltmann meter.



fieldsmart technology



ADRwater

AUCKLAND
 8 BEATRICE TINSLEY CRES
 ROSEDALE 0632
 PO BOX 302-248, NORTH HARBOUR
 AUCKLAND 0751
 T: (09) 444 2350 F: (09) 444 3085

HAMILTON
 1/21 RAILSIDE PLACE
 DINDALE 3204
 PO BOX 230
 RAGLAN 3265
 T: (07) 846 0602 F: (07) 846 0604

WELLINGTON HEAD OFFICE
 137 THORNDON QUAY
 WELLINGTON 6011
 PO BOX 3749
 WELLINGTON 6140
 T: (04) 472 7614 F: (04) 472 7658

CHRISTCHURCH
 UNIT 4, 89 VICKERYS ROAD
 WIGRAM 8042
 PO BOX 11 033, SOCKBURN
 CHRISTCHURCH 8443
 T: (03) 379 2628 F: (03) 379 2627