

R1T

# Tow Operator Guide

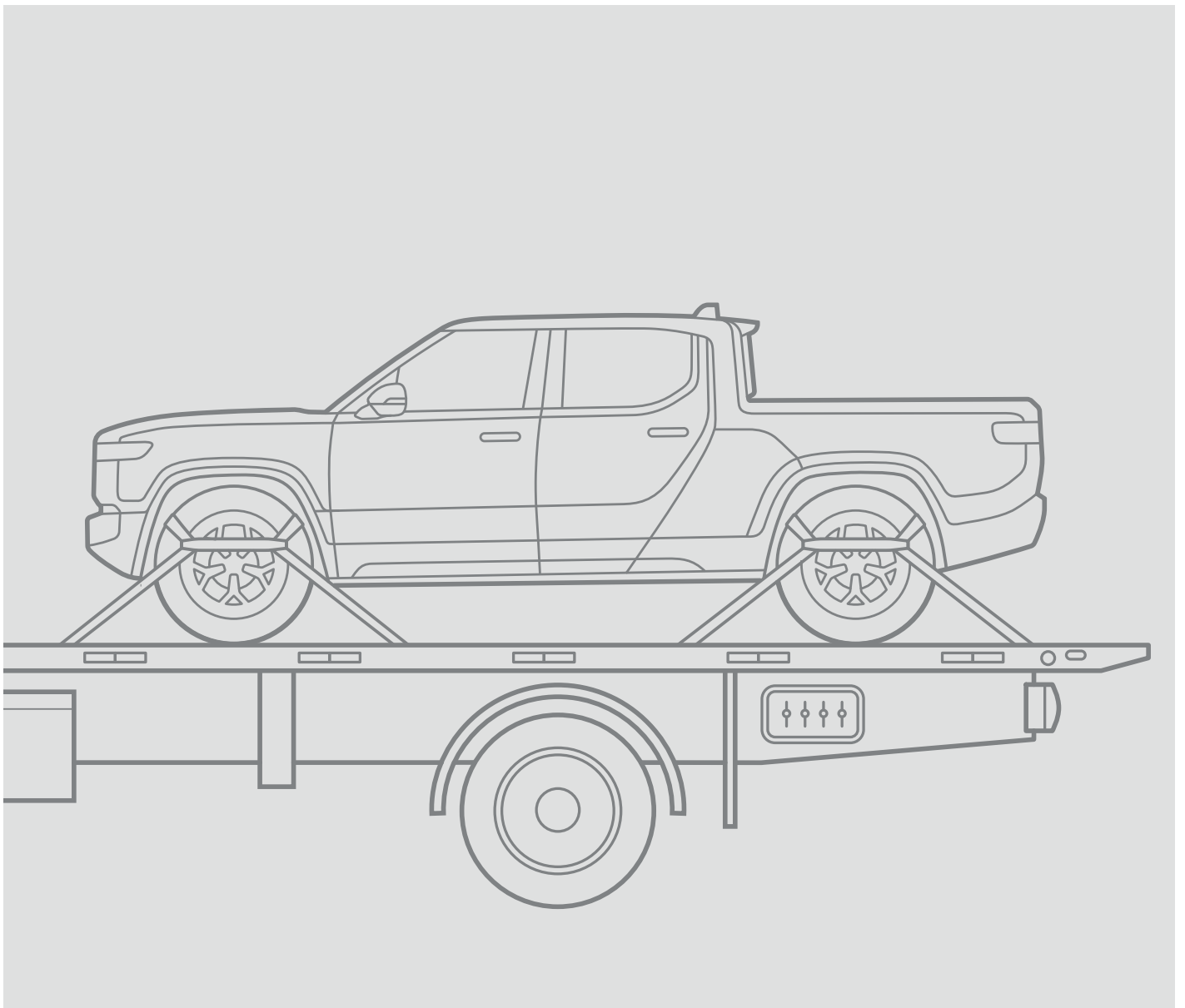



© 2021 Rivian Automotive, LLC. All rights reserved.

All information in this document and all vehicle software is subject to copyright and other intellectual property rights of Rivian Automotive, LLC, its affiliates, or its licensors. This material may not be modified, reproduced, or copied, in whole or in part, without the prior written permission of Rivian Automotive, LLC, its affiliates, or its licensors. Unless indicated otherwise, all trademarks are owned and registered by Rivian Automotive, LLC, its affiliates, or its licensors in the United States and/or other countries. Please visit <https://www.rivian.com/legal/brand> for Rivian's trademarks and service marks.

Software embedded or accessed by the vehicle may utilize open source software. Please visit <https://www.rivian.com/legal/open-source> for more information.

# Contents

<b>Transport the Vehicle</b> .....	<b>4</b>
Prepare the Vehicle for Towing .....	4
Load the Vehicle onto the Tow Truck .....	4
<b>Install the Tire Jack</b> .....	<b>6</b>
<b>Change a Tire</b> .....	<b>11</b>
<b>Manually Release the Charge Plug</b> .....	<b>13</b>
<b>Jump Start the 12 V Batteries</b> .....	<b>14</b>
<b>Manually Open the Hood</b> .....	<b>16</b>
<b>Access the 12 V Batteries</b> .....	<b>17</b>
<b>Customer Service</b> .....	<b>19</b>

# Transport the Vehicle



Only transport Rivian vehicles on a flatbed tow truck. To prevent damage, don't tow the vehicle behind another vehicle or with two wheels on the ground.

## PREPARE THE VEHICLE FOR TOWING

Follow these steps to tow the vehicle:

1. Ensure the front wheels face forward and are parallel with the vehicle.
2. Connect the vehicle to the tow truck winch with a nylon bridle or short endless loops through the lower control arms.



To prevent damage, don't use J-hooks to connect to any suspension components.

3. Press and hold the brake pedal.
4. Go to the **Settings** menu on the center display.
5. Choose **Vehicle**. Then choose **Service**.
6. Turn on **Park brake release**.
7. Release the brake pedal and confirm release of the electronic parking brake.

You can now load the vehicle onto the tow truck.

### NOTE

The park brake release will turn off after 15 minutes. You can also turn it off by putting the vehicle in **Park** or turning off **Park brake release** in the **Settings** menu in the center display.

## LOAD THE VEHICLE ONTO THE TOW TRUCK

Follow these steps to load the vehicle onto a tow truck:

1. Use the tow truck winch to pull the vehicle onto the tow truck deck.
2. Pull at 4 mph or less to prevent damage to the drive train.

### NOTE

If you pull too fast, the vehicle will stop and return to **Park**.

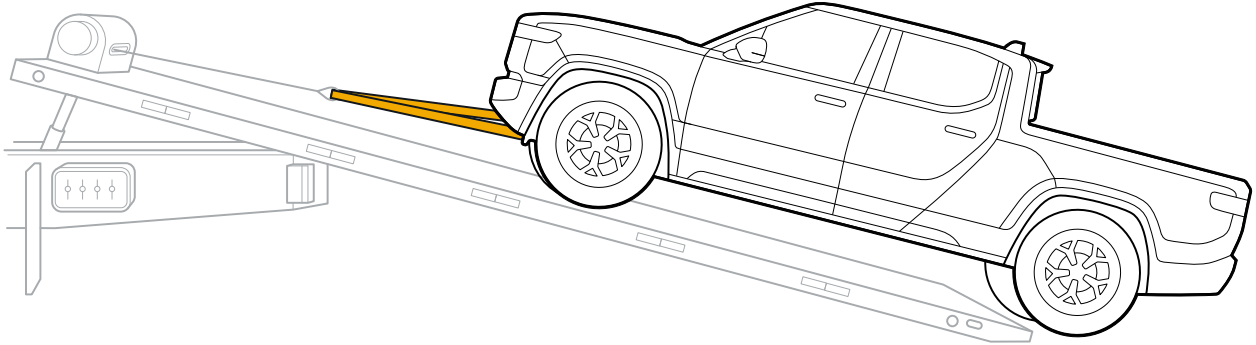

3. Tie down the vehicle using eight-point retention straps with two points of contact per corner.



**CAUTION**

To prevent damage, ensure the straps don't contact the brake lines or suspension components behind the tire.

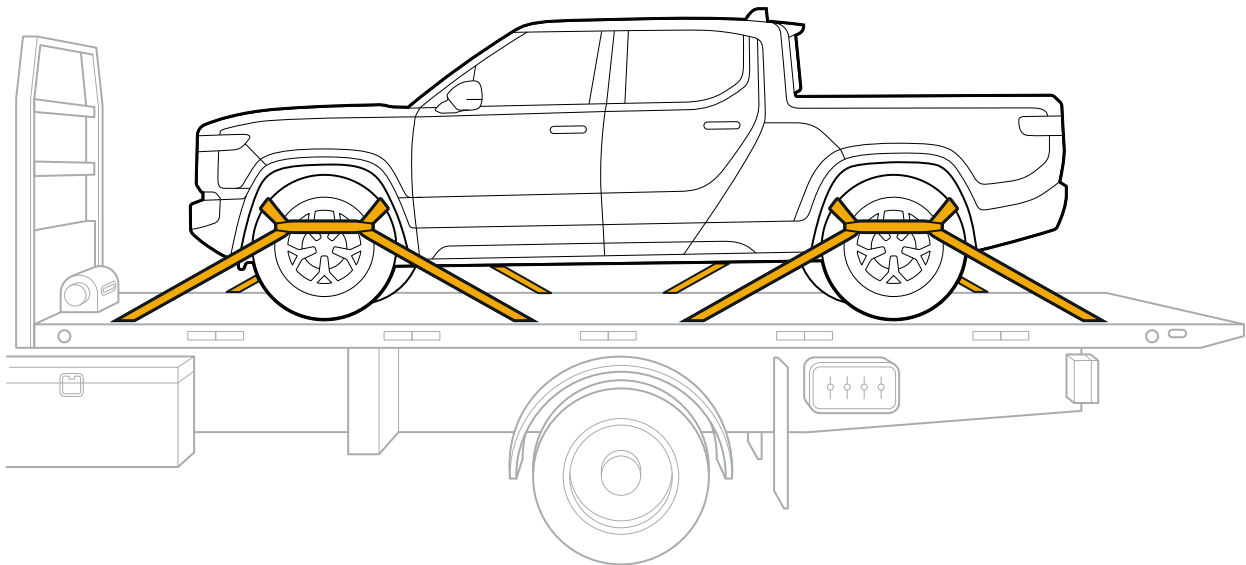

4. Put the vehicle into **Park**.
5. Go to **Drive Modes** in the center display. Choose **Sport** or **Conserve**. Then choose **Lowest** under **Ride Height**.

# Install the Tire Jack



## WARNING

- Don't service the vehicle on a narrow shoulder, near oncoming traffic, or on soft terrain.
- Make sure the surface is flat, firm, and high-friction.
- Don't install the tire jack over a grate or manhole cover.



## CAUTION

The Rivian-supplied tire jack should only be used for roadside emergencies to change a flat or damaged tire on a Rivian vehicle. Contact Rivian Service for other types of repairs.

Use the tire jack to lift the vehicle as follows:

1. Find a safe, level location.
2. Put the vehicle in **Park**.
3. Turn on the hazard lights.
4. Ensure all passengers exit the vehicle and stay in a safe location.
5. Secure the vehicle by placing wheel chocks diagonally opposite the tire to be changed.

### NOTE

The electronic park brake is only on the rear wheels. There is an increased risk of rolling when replacing a rear tire.

## INSTALL THE TIRE JACK

6. Access the spare tire compartment in the truck bed.

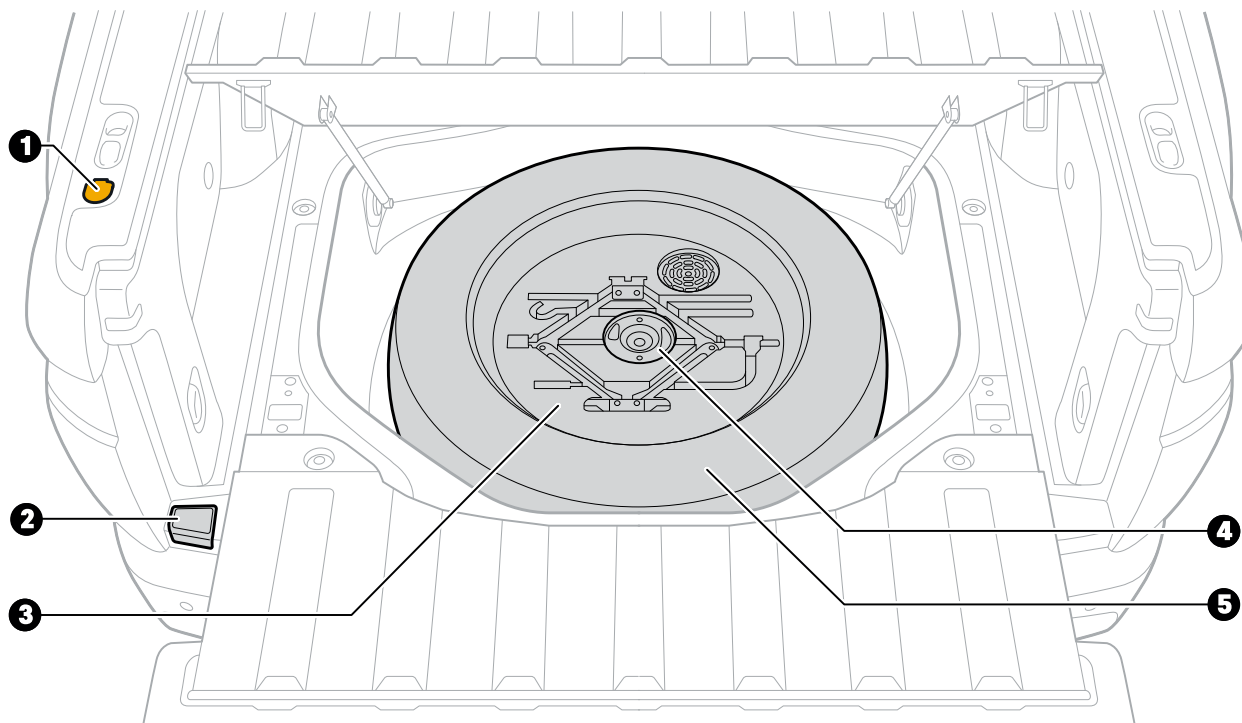

Item	Description
1	Tailgate release button
2	Spare tire compartment release lever
3	Tire jack kit
4	Spare tire wing nut
5	Spare tire

- a. Ensure that the truck bed is empty, and that there aren't any objects on the lid.
  - b. Open the tailgate.
  - c. Lift the release lever to open the spare tire compartment. You can push the spare tire compartment lid to a vertical position if needed.
7. Remove the spare tire and the tire jack kit from the spare tire compartment.
8. Inflate the tire to the recommended pressure.

## INSTALL THE TIRE JACK

---

9. Go to **Drive Modes** in the center display. Choose **Off-Road**. Then choose **Max** under **Ride Height**.

### NOTE

You can't adjust ride height with **Tire Change** mode on.

10. Go to **Settings**. Choose **Vehicle**. Then choose **Service**. Turn on **Tire Change** mode.
11. Locate the vehicle jack point. There are two jack points on each side under the rocker panel.

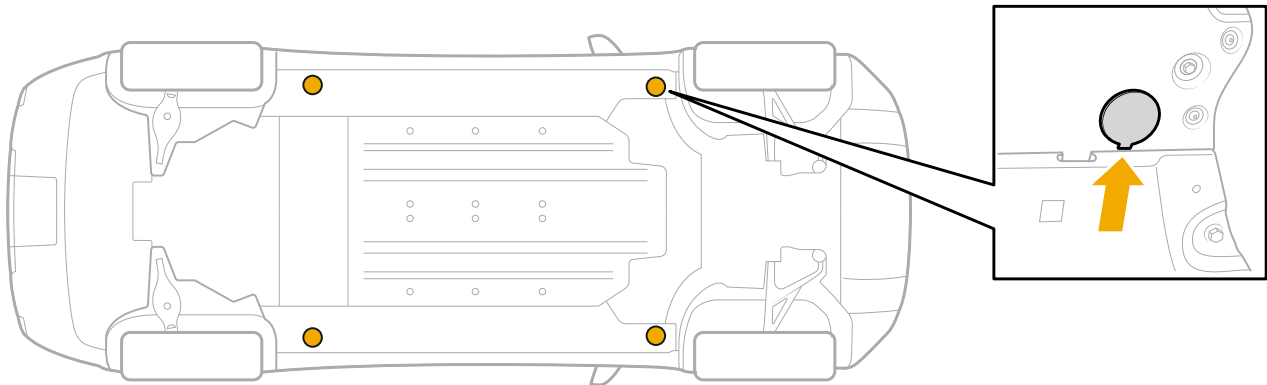

12. Remove the jack point cover by applying force to the inner edge.



## INSTALL THE TIRE JACK

13. If replacing a rear tire, slide the jack riser base (3) out of the storage plate (4) included in the tire jack kit. Then place the jack on top of the riser base.

### NOTE

If replacing a front tire, don't use the riser base.

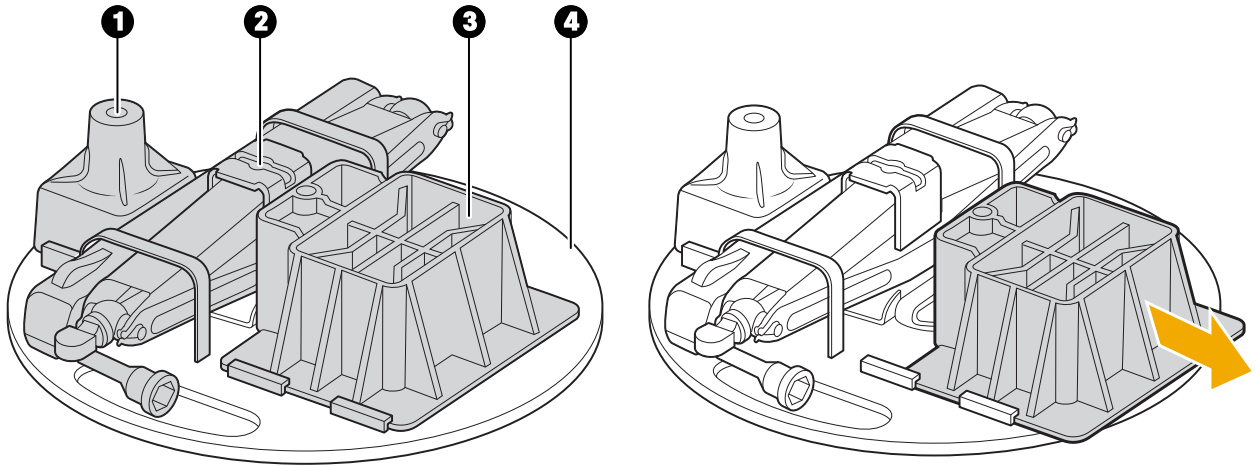

Item	Description
1	Jack adaptor
2	Tire jack
3	Jack riser base
4	Storage plate



**CAUTION**

Always use the jack adaptor to prevent damage to the vehicle when lifting with a tire jack.

14. Align the top of the jack adaptor (1) with the hole at the vehicle jack point.
15. Place the tire jack (2) under the jack adaptor.

## INSTALL THE TIRE JACK

---

16. Raise the jack slightly to ensure that it's straight and the top of the jack aligns with the jack adaptor.

### NOTES

Use the tools provided with the tire jack kit to raise the jack. You don't need to use the extenders.

If the jack begins to tilt, lower the jack. Reposition the jack rearward approximately 2 in (5 cm) and try again.

**FRONT**

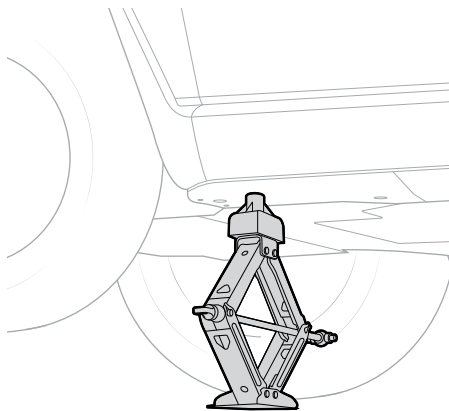

**REAR**

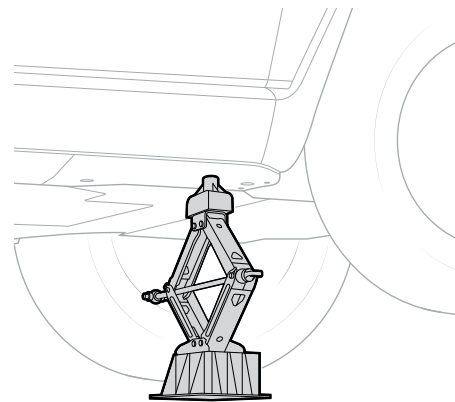

# Change a Tire

With the [jack installed](#) in the jack point, lift and remove the wheel by following these steps:

1. Raise the jack to lift the vehicle slightly, keeping the tire on the ground.
2. Loosen the lug nuts counter-clockwise one half turn with a lug wrench.

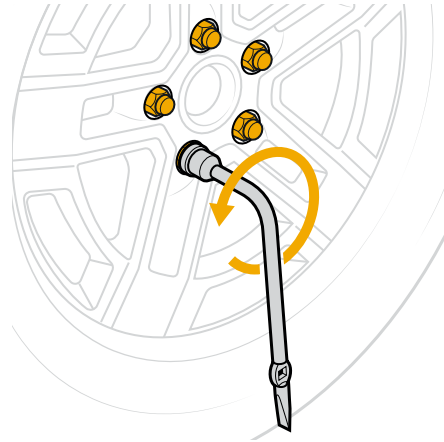

**DANGER**

Don't place any part of your body under the vehicle while it's lifted.



**CAUTION**

If the ride height adjusts while working on the vehicle, stop raising the jack and ensure **Tire Change** mode is turned on.

3. Raise the jack to lift the vehicle so the tire doesn't touch the ground.
4. Fully loosen and remove the lug nuts.
5. Remove the wheel from the vehicle by gripping the tread of the tire and pulling it straight out.

Install the new or spare tire as follows:

1. Lift the wheel and align the wheel studs with the holes in the rim.
2. Push the wheel onto the hub.

## **NOTE**

Ensure the wheel is fully seated to the hub.

3. Reinstall the lug nuts and tighten them by hand.

## CHANGE A TIRE

---

4. Lower the jack until the tire touches the ground but doesn't carry the full weight of the vehicle.
5. Torque the lug nuts in an alternating star pattern to 190 N•m. If you don't have a torque tool, tighten until the lug nuts cannot be turned further.

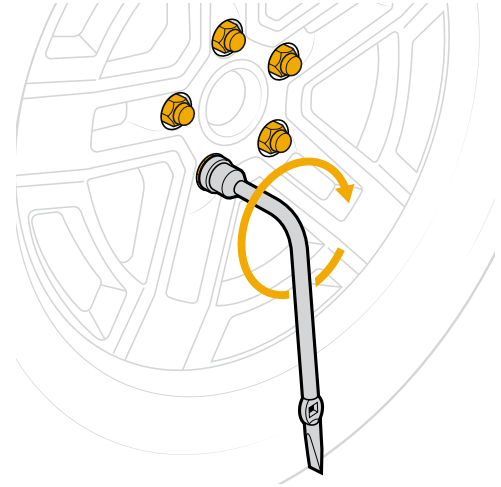
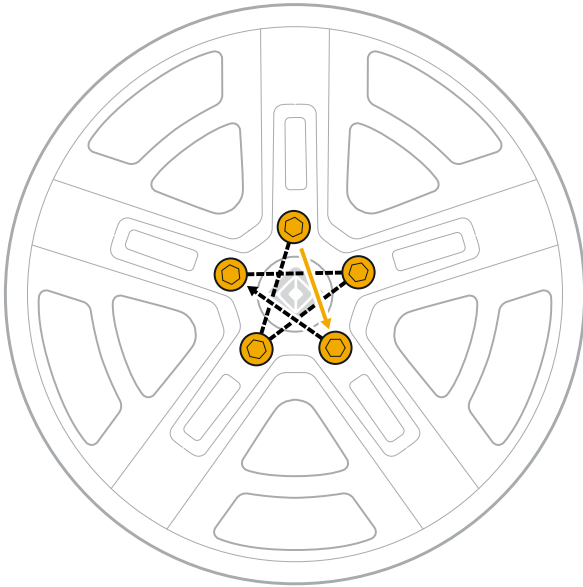

6. Lower the jack until the full weight of the vehicle rests on the tires.
7. Remove the jack, jack riser base, and wheel chocks (if used).
8. Store the removed wheel and the jack kit in the spare tire compartment.
  - Place the wheel with the outside of the rim facedown.
  - Secure the jack kit with the fastener.
9. Go to **Settings** in the center display. Choose **Vehicle**. Then choose **Service**. Turn off **Tire Change** mode.
10. Go to **Drive Modes**. Choose your previous drive mode and ride height.
11. Repair or replace the removed wheel once you've reached your destination.

# Manually Release the Charge Plug

If the charge plug won't release from the charge port after you stop a charge session, manually release it by following these steps:

1. Open the vehicle hood.
2. Remove the trim panel from the driver side of the vehicle.
3. Gently pull the cable to release the charge plug.
4. Remove the charge plug from the charge port.
5. Replace the trim panel.
6. Close the hood.

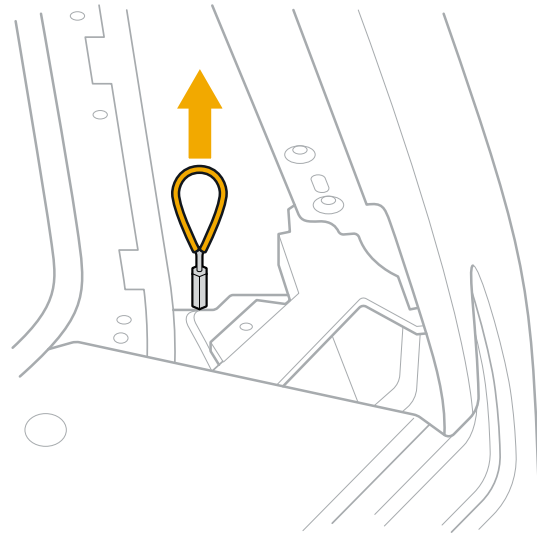
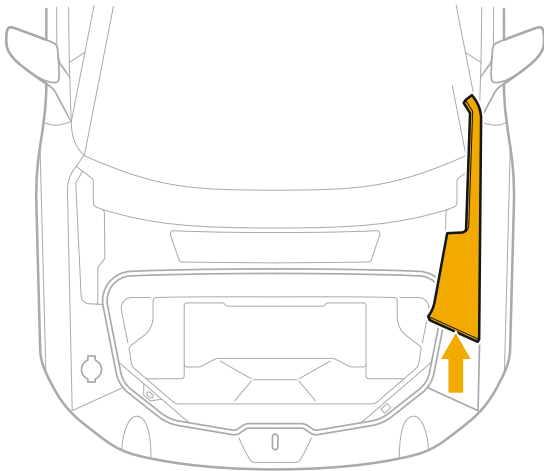

# Jump Start the 12 V Batteries

The vehicle has two 12 V batteries under the hood. Signs of discharged 12 V batteries include the following:

- The doors and storage areas don't unlock.
- The vehicle doesn't respond to the key fob.
- The lighting doesn't illuminate.
- The displays don't turn on.



Don't use a Rivian vehicle to jump start another vehicle.

Before you begin, ensure that you have an adequate power source to jump start a Rivian vehicle.

- If using a tow truck to jump start, the tow truck needs to be running until the Rivian vehicle powers up.
- If using a jump box, it needs to maintain a steady voltage of 12.5 V at 15 A (30 A peak).

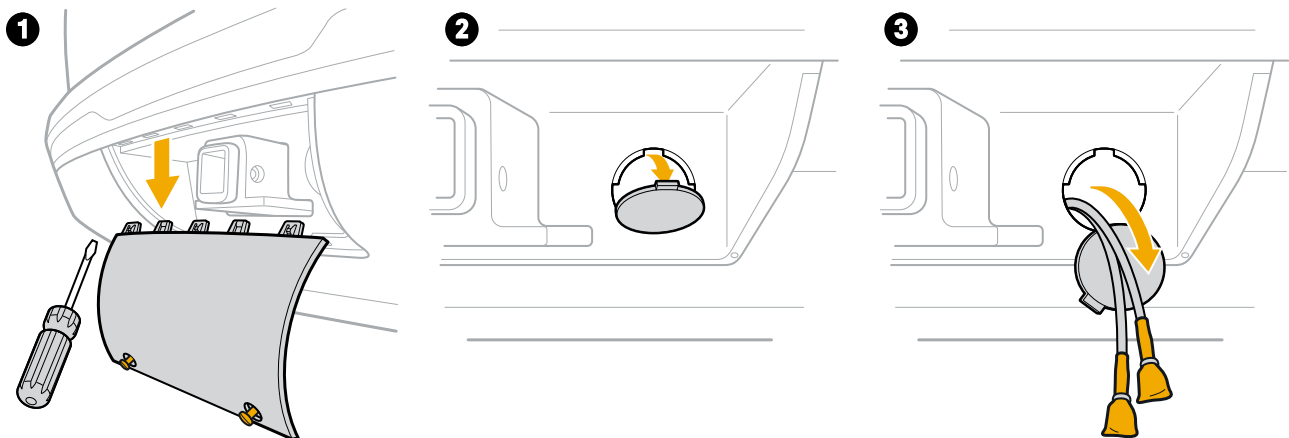

1. Remove the trailer hitch cover to access the jump start wire harness.
2. Remove the round access panel to the right of the trailer hitch.
3. Pull out the jump start wire harness and remove the protective tape from the connectors.
4. Connect the positive lead (red) to the red lead on the jump start wire harness and negative lead (black) to the black lead on the jump start wire harness.

Once the vehicle has enough power, the displays will turn on. You can unlock the doors, front trunk, and charge port door. When the vehicle fully powers on, you can drive if the vehicle battery has enough range.

### NOTES

- You may need to reset the vehicle after it powers on. To reset, press the left thumb control button on the steering wheel and the hazards lights button on the overhead console. Press both buttons at the same time and hold for ten seconds.
- If the vehicle battery has drained completely, you may need to [transport the vehicle](#) to a Rivian Service Center.

# Manually Open the Hood

Follow these steps if the hood won't open normally:

1. Remove the screws from the left front wheel liner and lower the front skid plate to access the hood release cable.

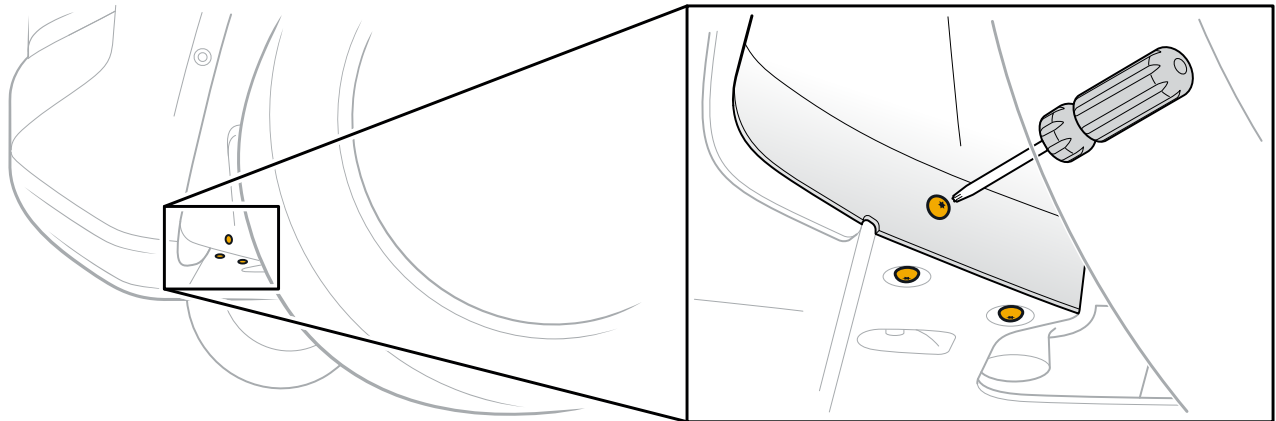

2. Pull the cable to release the hood latch. If the latch doesn't release, have a second person lift up and push down on the hood while you pull on the cable.

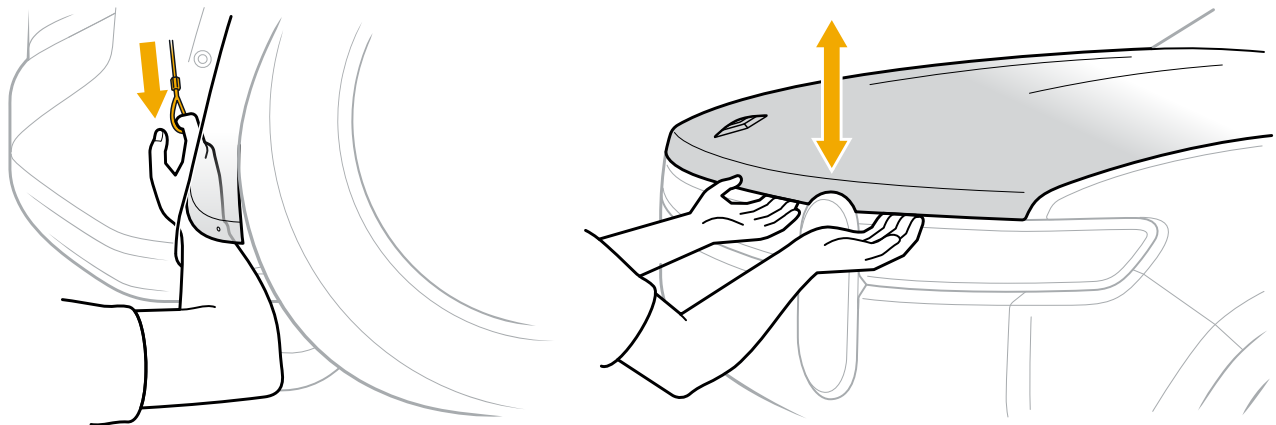



# Access the 12 V Batteries

Access the 12 V batteries as follows:

1. Remove the air intake cover by gently pulling up to release the clips.
2. Remove the air intake duct to access the 12 V batteries.

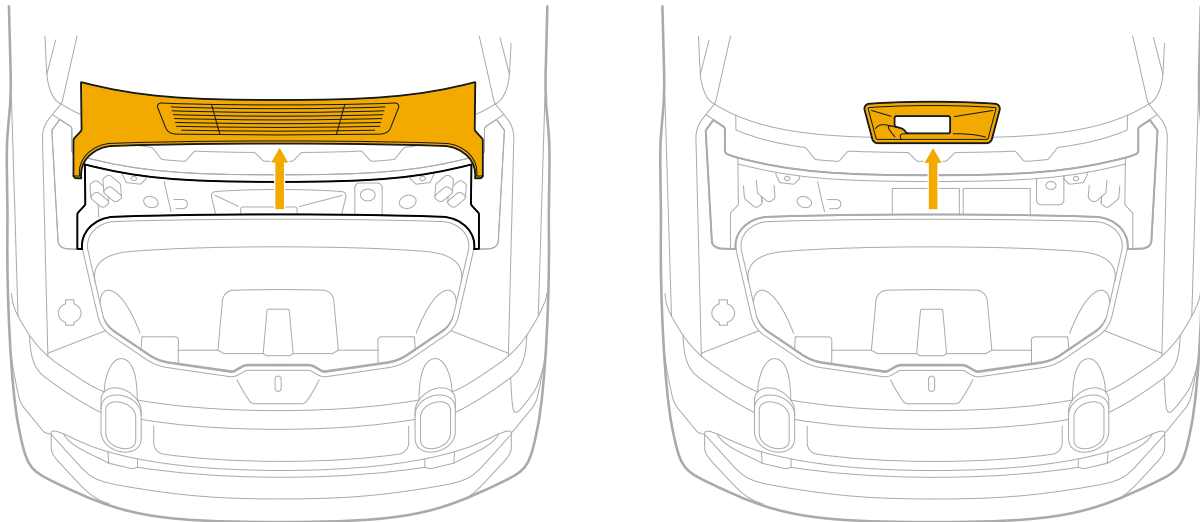

To recharge the 12 V batteries, connect to the primary battery on the driver's side as follows:

1. Connect the negative lead (black) to the negative battery terminal (-).
2. Connect the positive lead (red) to the positive battery terminal (+).

## NOTE

If you have a Y-cable or two sets of cables, connect both batteries and charge at the same time.

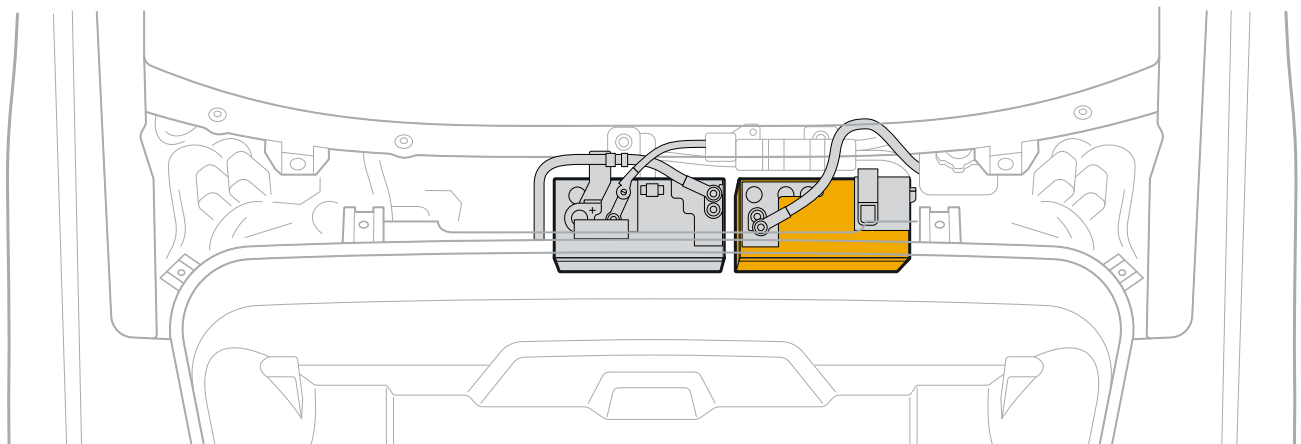

Once the vehicle has power, the displays will turn on. You can unlock the doors, front trunk, and charge port door. When the vehicle fully powers on, you can drive if the vehicle battery has enough range.

### NOTES

- You may need to reset the vehicle after it powers on. To reset, press the left thumb control button on the steering wheel and the hazards lights button on the overhead console. Press both buttons at the same time and hold for ten seconds.
- If the vehicle battery has drained completely, you may need to [transport the vehicle](#) to a Rivian Service Center.

# Customer Service

Still need help? Connect with us.



## CUSTOMER ENGAGEMENT CENTER

---

(888) RIVIAN1 / (888) 748-4261  
[customerservice@rivian.com](mailto:customerservice@rivian.com)  
[rivian.com](https://rivian.com) Support Center and Chat

## INSURANCE

---

(888) RIVIAN8 / (888) 748-4268

## ROADSIDE ASSISTANCE 24/7

---

(844) RIVIAN4 / (844) 748-4264

## SERVICE 24/7

---

(855) RIVIAN5 / (855) 748-4265