

NOTE:
 1. ALL CHAMFERS TO BE 0.030" X 45° UNLESS OTHERWISE NOTED
 2. MATERIAL TO BE A36 HOT ROLLED STEEL
 BLANCHARD GROUND TO .500" ± .025"

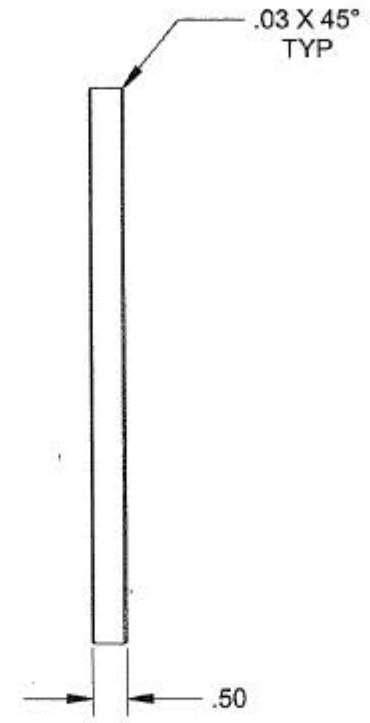
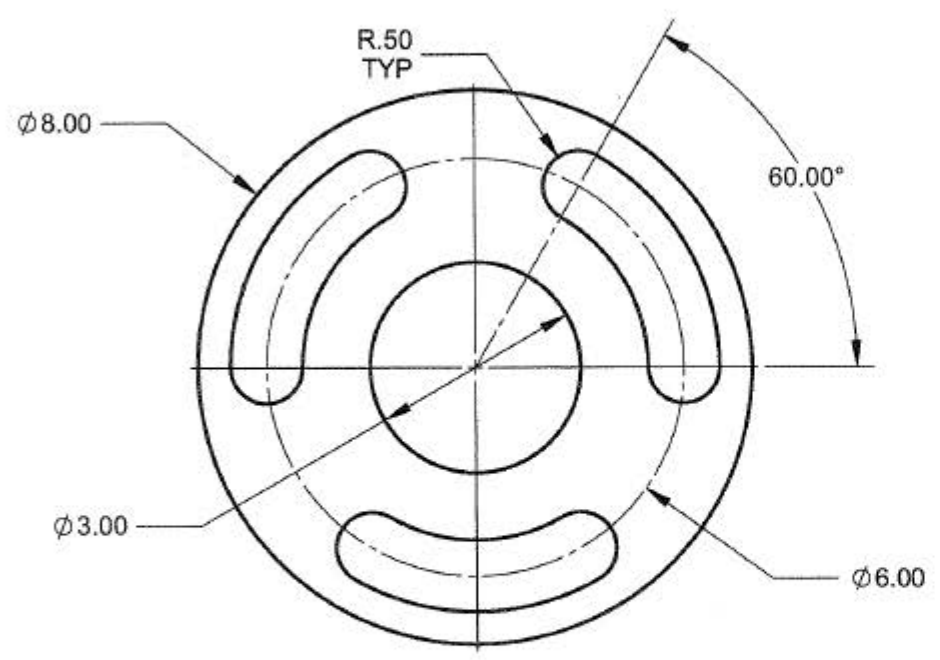

		A36 HOT ROLLED STEEL		
QTY	PART NUMBER	ITEM DESCRIPTION	ITEM	

REV	E.C.N. NO.	REVISION DESCRIPTION	REV BY	DATE	CHK BY	DATE	APP BY	DATE
A		ORIGINAL RELEASE						

SURFACE TREATMENT	NONE	EXCEPT AS NOTED: ALL CORNERS MUST BE AS FOLLOWS INSIDE: 1.3 X 45° OR 1.3 R WALL OUTSIDE: 3.8 X 45° OR 1.3 R
HEAT TREATMENT	BLACK OXIDE	EXCEPT AS NOTED: ALL DIMENSIONS IN METRIC TOLERANCE DECIMAL .3 ±0.8 .39 ±0.4 .390 ±0.13 .3950 ±0.015 ANGULAR ±0'30"
FIRST USED ON	TRAINING	EXCEPT AS NOTED: WELDING TOLERANCE MUST BE AS FOLLOWS ±.3

HURCO

HURCO COMPANIES, INC. INDIANAPOLIS, IN 46268 U.S.A.

DESCRIPTION
SLOT PLATE

DRWG: BMK	DATE: 11/10/11	CHECKED:	DATE:	APPROVED:	DATE:
SCALE: 1:2	SIZE: B	DRAWING: Slot Plate		DWT: 1	REV: A
UNIT OF MEAS: PC				QTY: 1	

